

88521795 C Stainless Steel Top Kitchen Island

Dear Our Valuable Customers.

Please follow our assembly instructions in every step,
we guarantee that you will get the perfect merchandise.

Thank you so much for purchasing our quality products.



Casual Attire For Today's Home

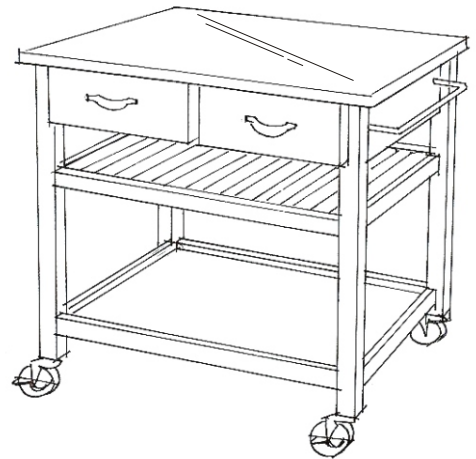

Part List

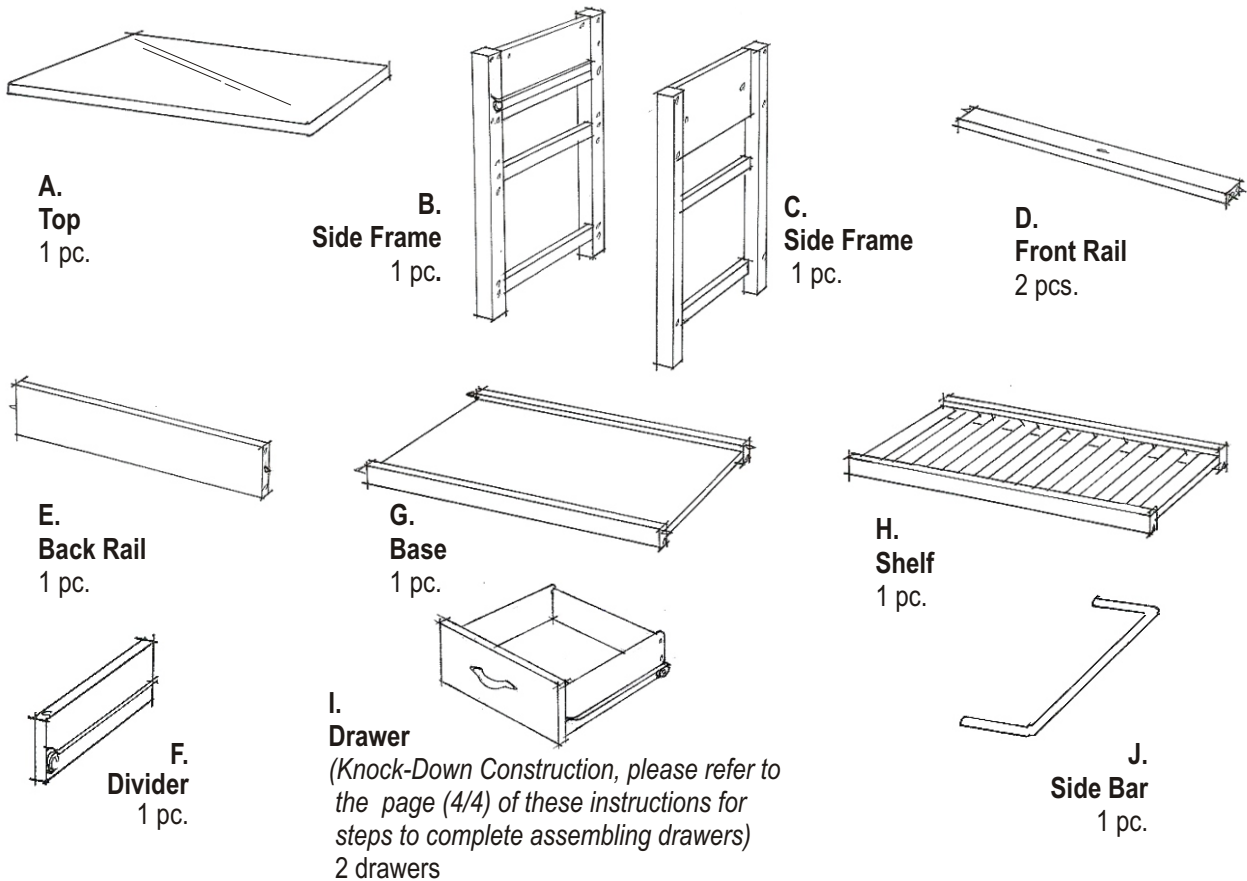

Hardware List

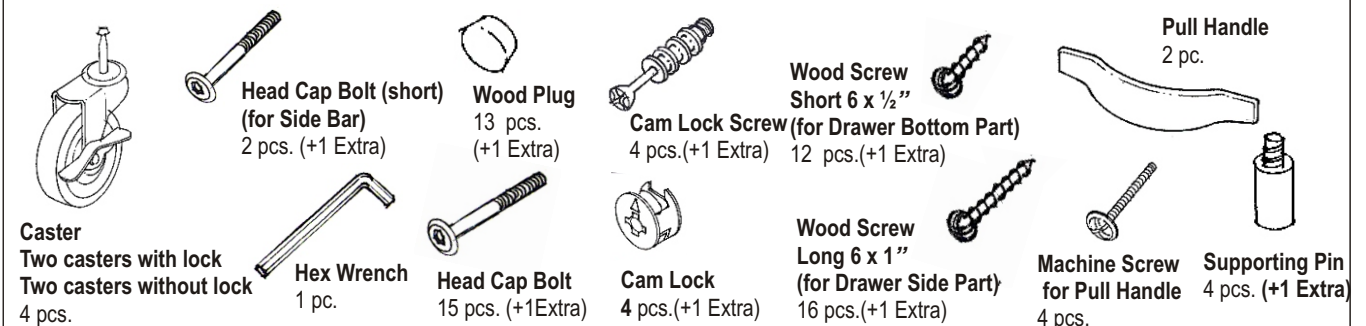

Tools Required For Assembly : Philips screwdriver

Assembly Instructions 2/4

IMPORTANT

Do not tighten up all the screws until each part is properly assembled. You should keep Hex Wrench in the safe place as you may need to tighten up the Head Cap Bolts in the future.

STEP 1

Turn the Side Frame (B) upside down on the soft material.

Attach the locking caster to the leg with ↑ sign, and the non-locking caster to the other leg.

Do the same for the Side Frame (C).

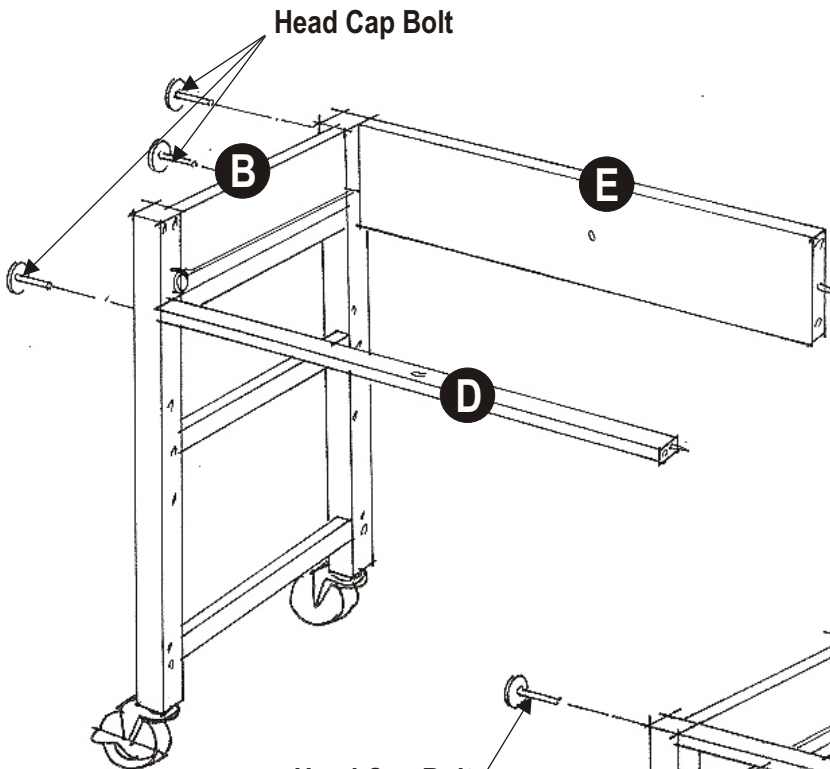
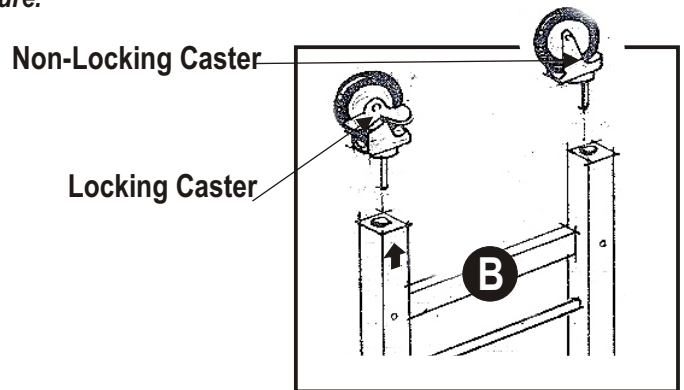

STEP 2

Attach the Front Rail (D) and Back Rail (E) to the Side Frame (B).

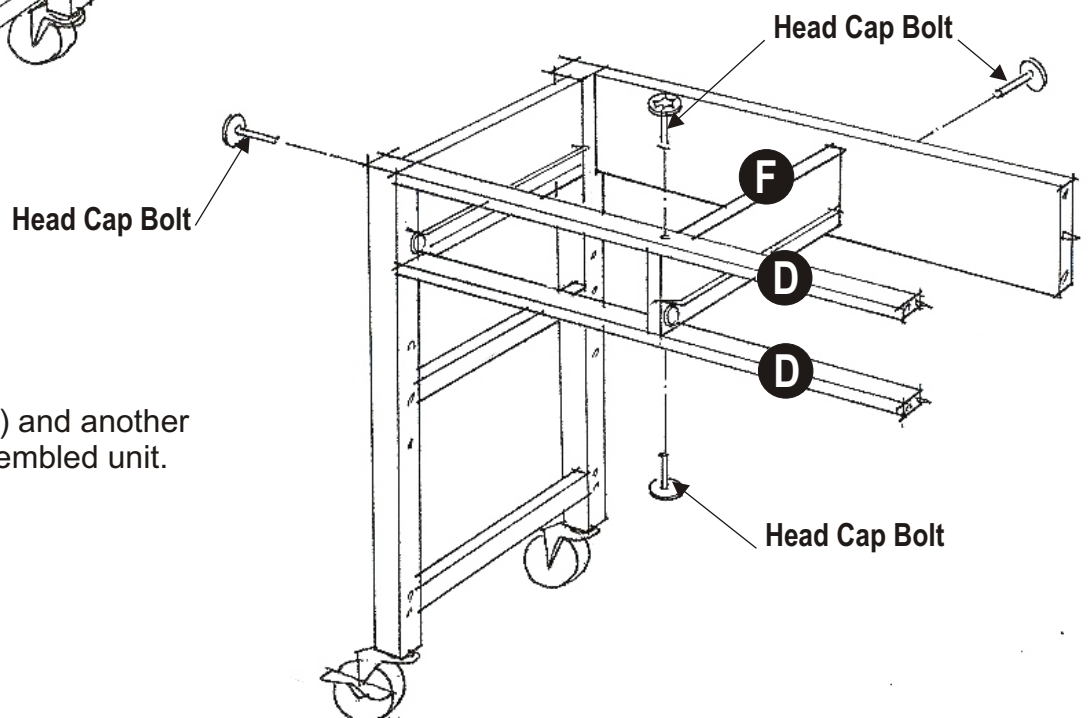

STEP 3

Attach the Divider (F) and another Front Rail to the assembled unit.

Assembly Instructions 3/4

STEP 4

Attach the Base (G) and Side Frame (C) to the assembled unit.

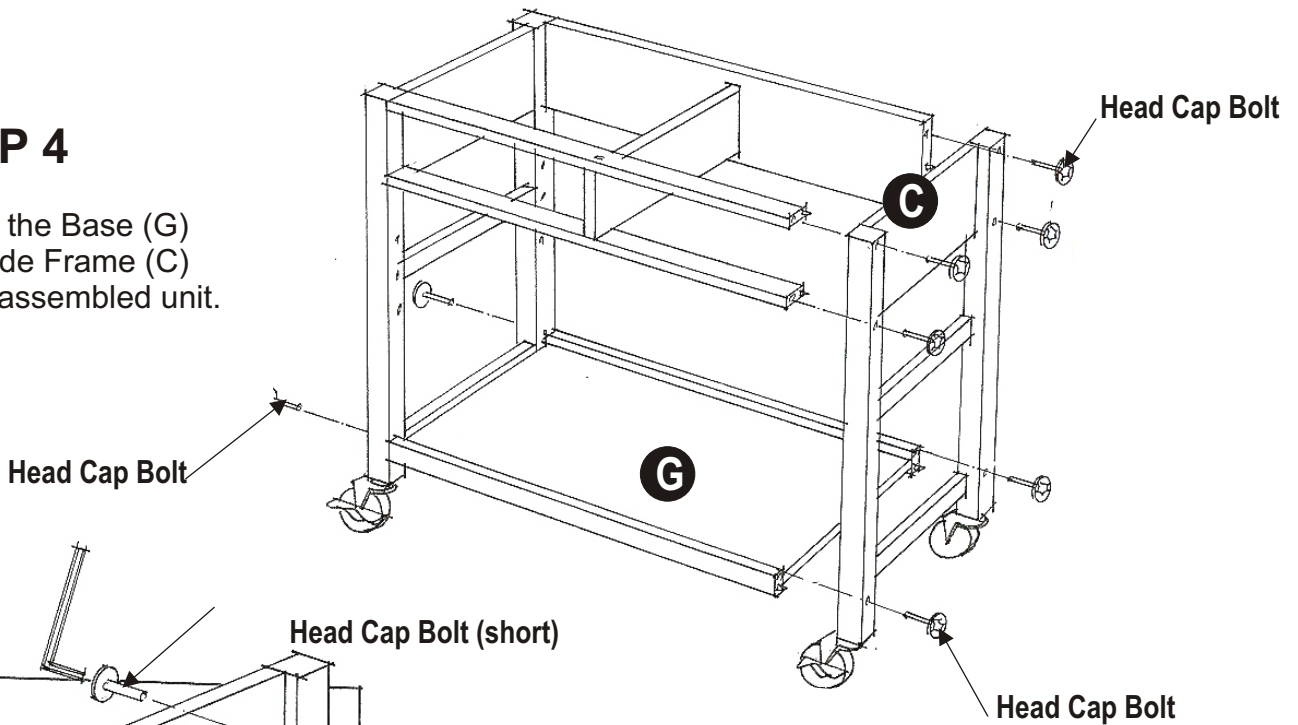

STEP 5

Attach the Side Bar (J) to the Side Frame (C).

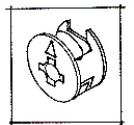
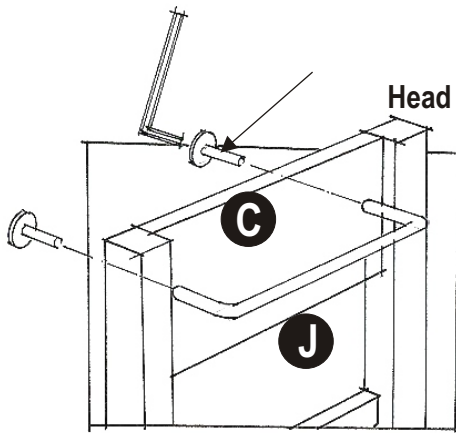

Cam Lock Screw

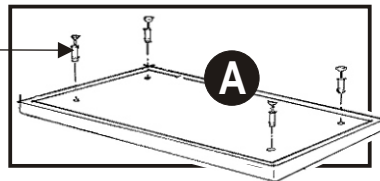

STEP 6

Put the Cam Lock Screws into the holes at the back of the Top (A). Place the Top (A) on the assembled unit. Place the Cam Locks into the holes of the Side Frame (B) and (C). Make sure the Arrow sign is on top. Tighten up all the Cam Locks to secure the Top with the body. Insert the Supporting Pins into both side frames at the desired level. Place Shelf (H) and slide the Drawers (I) into place.

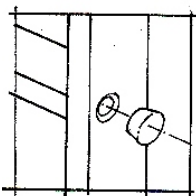
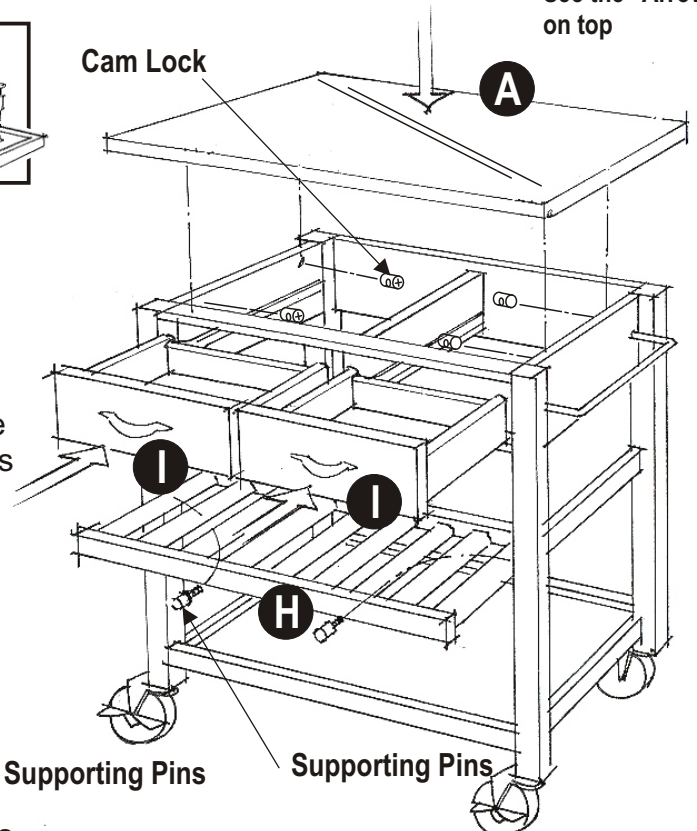

STEP 7

Cover all holes with Wood Plugs

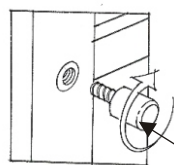

Drawer

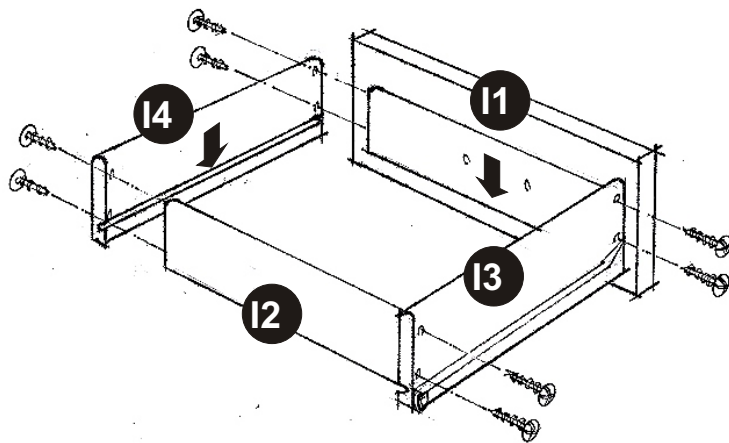

Figure 2

Turn the assembled drawer over and slide the Plywood Bottom Part (15) into the grooves of Side Parts (13) and (14). Be sure to push the plywood bottom part all the way forward, so it meets the Front Part (11).

Insert the remaining 1/2" screws (6 pcs.) into the pre-drilled holes at the Bottom Part (15), then tighten up all screws

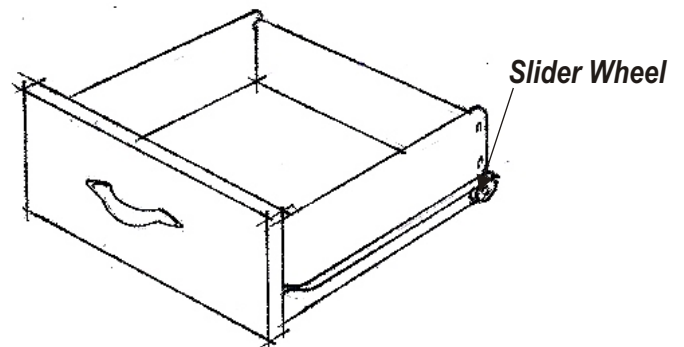

Figure 1

Line up Side Parts (13) and (14) to the Front Part (11) and Back Part (12). Make sure the ↓ sign on each part is going down. Using a *Philips* screwdriver, insert 1" screws into each of the 4 pre-drilled holes on the sides (13) and (14), then tighten half way.

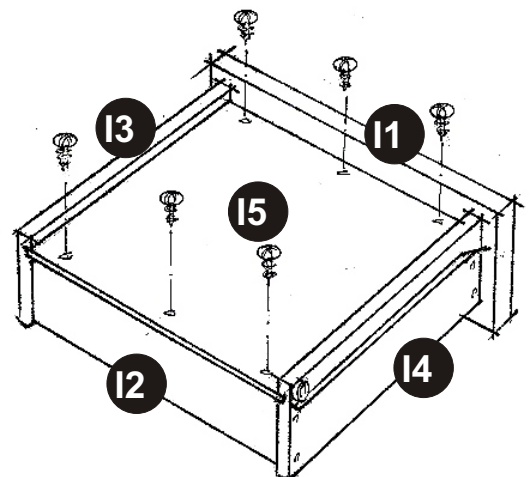
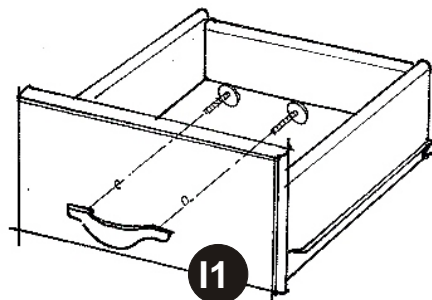

Figure 3

Assemble the Pull Handle to the Front Part (11) with Machine Screw.



* If you are missing any of these parts, please contact our DMI Customer Service Department at 1-877-831-0319 or fax us at 1-800-755-2878.

Part List

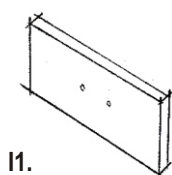

11. Front Part
2 pcs.

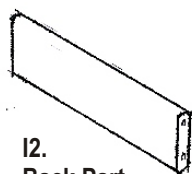

12. Back Part
2 pcs.

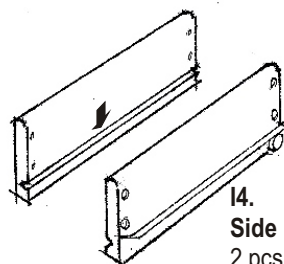

13. Side Part
2 pcs.

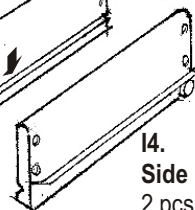

14. Side Part
2 pcs.

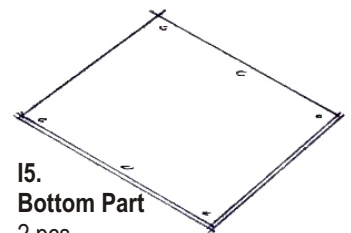

15. Bottom Part
2 pcs.