

88508695 C

Stainless Steel Top Kitchen with Wood Breakfast Bar

Thank you for purchasing our quality products. Please carefully check the quantity of the parts and hardware. Please also read this assembly instructions until you understand clearly how to put the parts together, then start assembling step by step.



Casual Attire For Today's Home

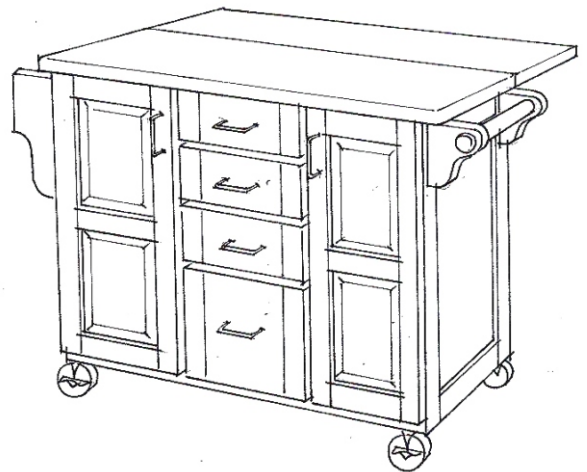

Thai Patent Pending Numbers 077214

PART LIST

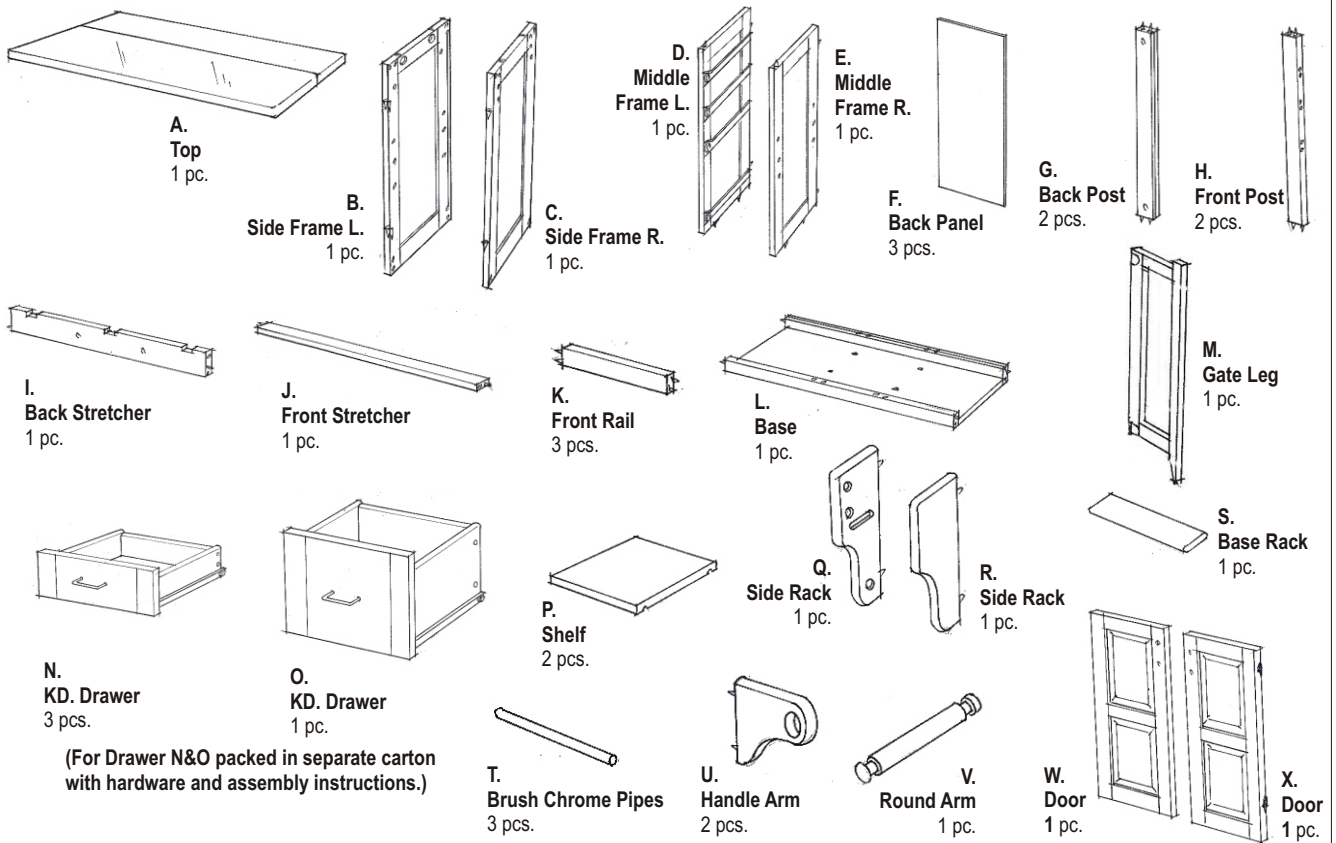

HARDWARE LIST

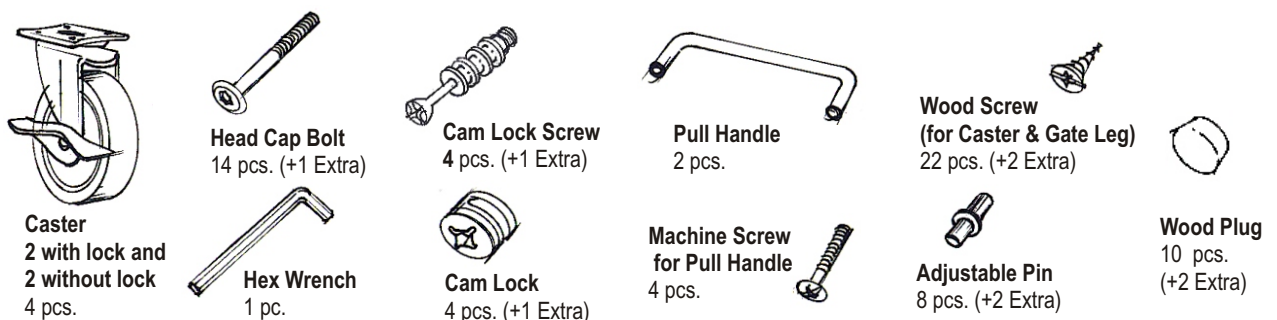

Tools Required For Assembly : Philips screwdriver

Assembly Instructions 2/4

IMPORTANT

Do not tighten up all the screws until each part is properly assembled.
You should keep Hex Wrench in the safe place as you may need to tighten up the Head Cap Bolts in the future.

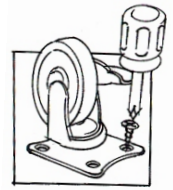

STEP 1

Attach 4 Casters to the underside of the Base (L), put the 2 Casters with lock in front as you first need to lock the cart from moving. (See sticker in the bottom indicating front side)

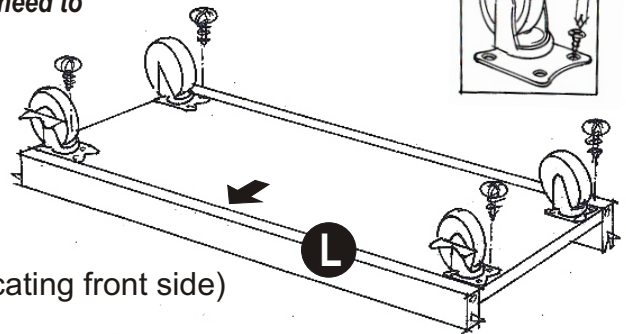

STEP 2

Attach the Back Post (G) and Front Post (H) to the Middle Frame (D) and (E).

Attach the assembled Middle Frame (D) and (E) to the Base (L).

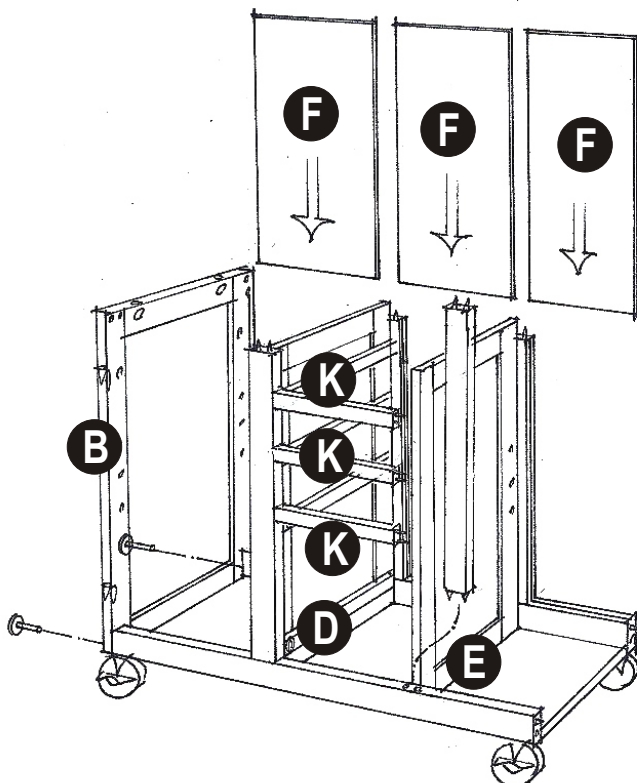
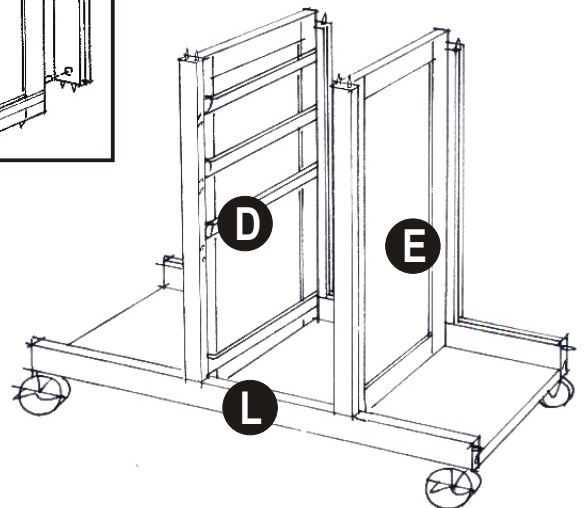
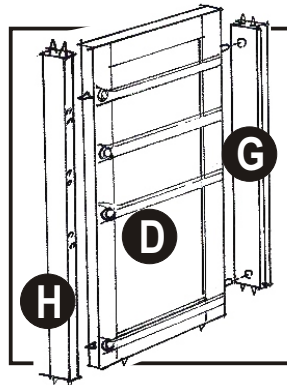

STEP 3

Put the Front Rail (K) in between the Middle Frame (D) and (E).

Attach the Side Frame (B) to the side of the unit with Head Cap Bolts.

Slide the Back Panels (F) into place.

Assembly Instructions 3/4

STEP 4

Attach the Back and Front Stretcher (I), (J) to the assembled unit with Head Cap Bolts.

Attach the Side Frame (C) to the other side of the unit with Head Cap Bolts.

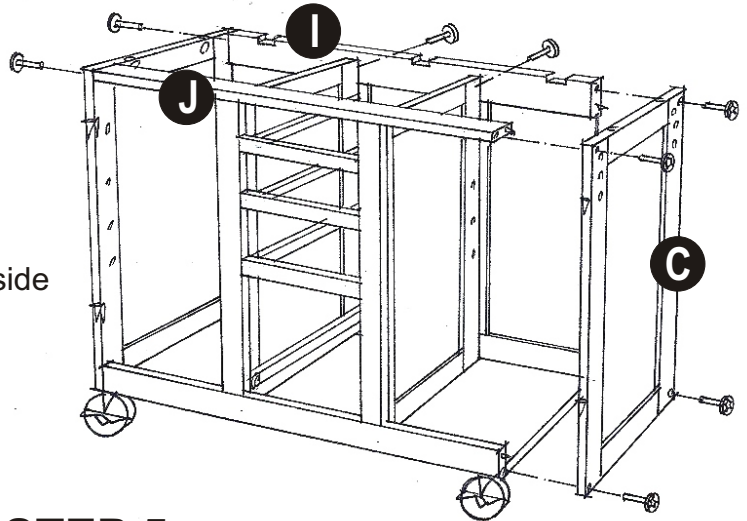

STEP 5

Attach the Side Rack (Q) to the Side Frame (B) with the Head Cap Bolts.

Attach the Brush Chrome Pipes (T) to the pre-drilled holes of Side Rack (Q).

Attach the Base Rack (S) to the Side Rack (Q).

Attach the Side Rack (R) to the Side Frame (B), using Head Cap Bolts.

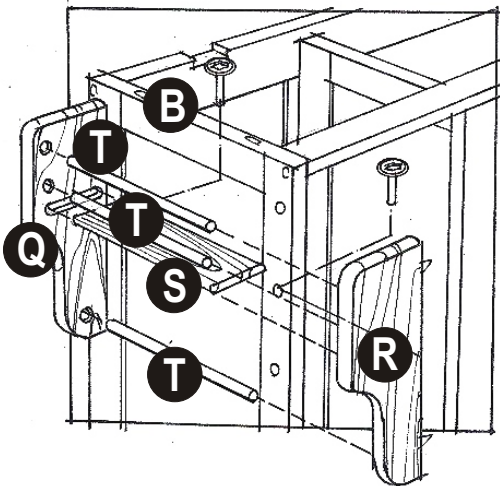

STEP 6

Attach the Handle Arm (U) to the Side Frame (C) with Head Cap Bolts.

Slide the Round Arm (V) into place.

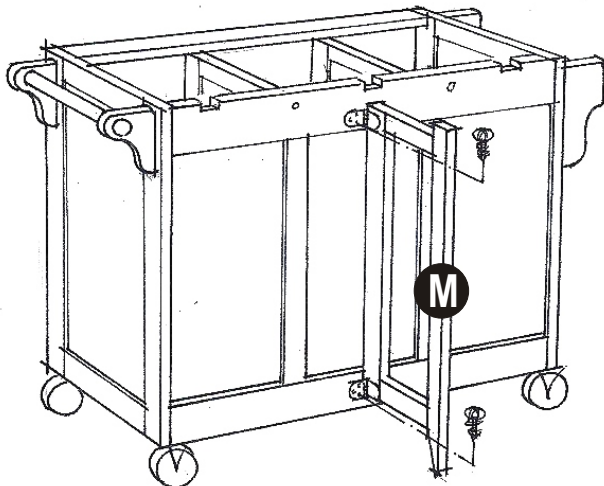
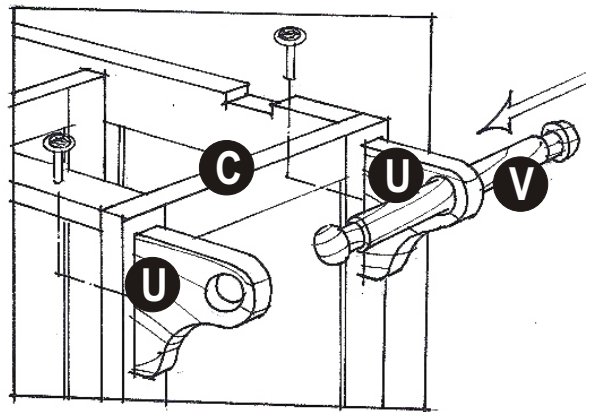

STEP 7

Attach the Gate Leg (M) at the rear and connect it to the unit with Wood Screws.

Holding Gate Leg and rear frame with Wood Screw

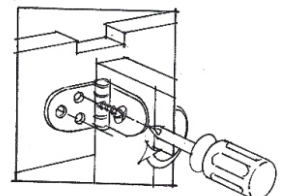

Assembly Instructions 4/4

STEP 8

Turn the Top (A) upside down and put the Cam Lock Screws to the pre-drilled holes.

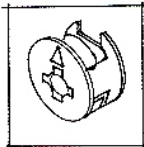
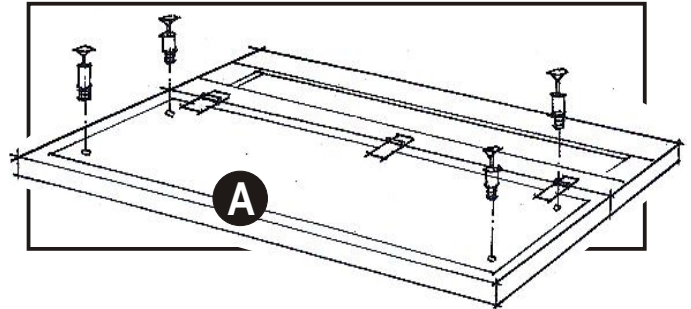
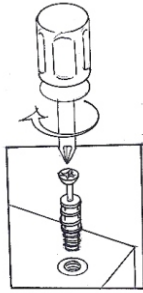

See the "Arrow" on top

STEP 9

Place the Top (A) on the assembled unit.

Place the Cam Locks into the holes of the Side Frames (B) and (C).

Make sure the Arrow sign on top. and tighten all the Cam Locks as to secure the Top with the body.

Insert the Adjustable Pins into the Side Frame (B), Middle Frame (D) and Side Frame (C), Middle Frame (E) at the desired level.

Place Shelf (P) into place.

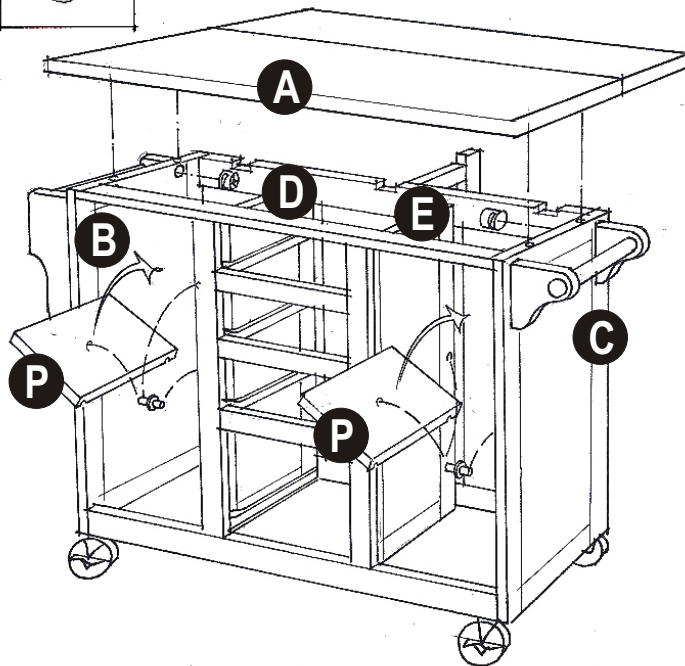

STEP 10

Attach the Pull Handles to the Door (W) and (X) using the Machine Screws.

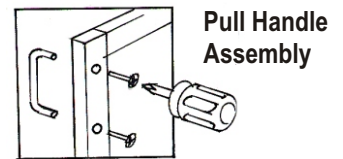
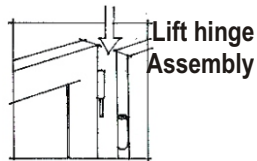

Attach the Door (W) and (X) to the Side Frame (B) and (C), slide the door lift hinges into the side frame lift hinges.

See Assembly Instructions for Drawers in the separate carton.

Slide the Drawers (N) and (O) into place.

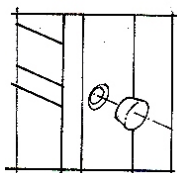
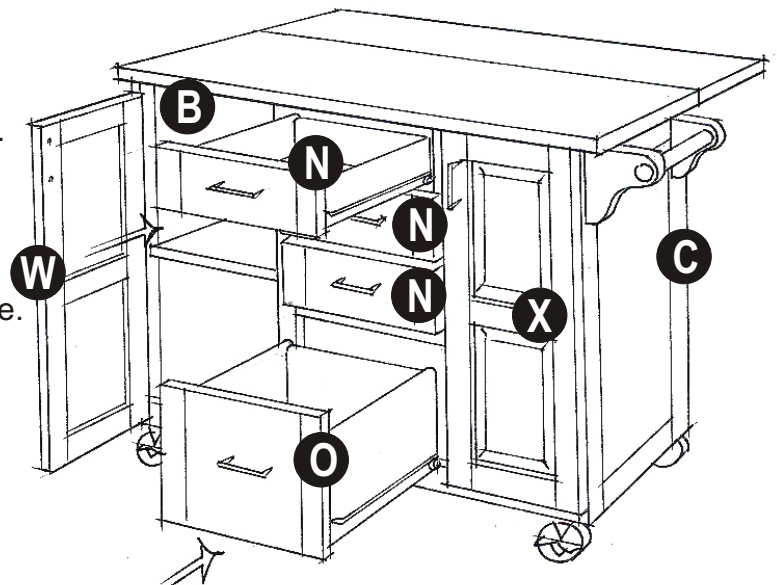

STEP 11

Cover all holes with Wood Plugs

88508695 C Drawer (N)

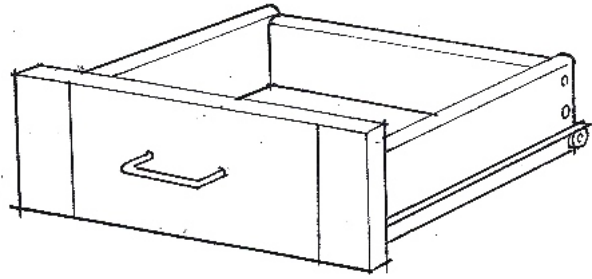

Unit Part List

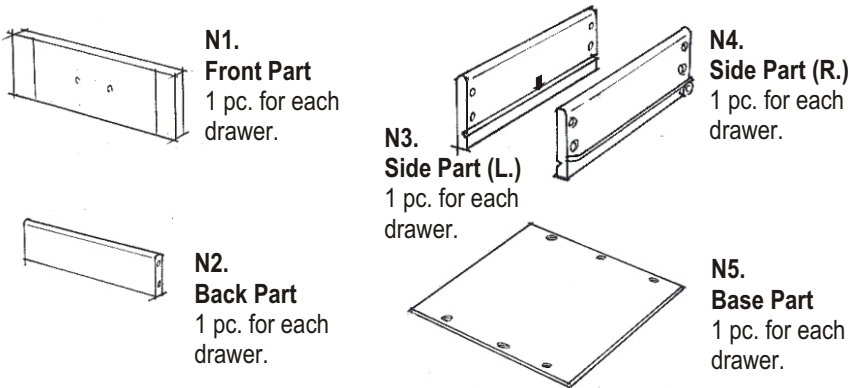

HARDWARE LIST

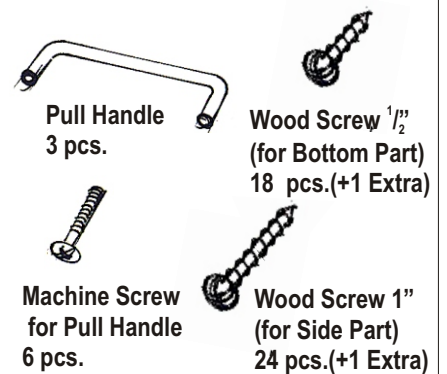

Assembly Instructions

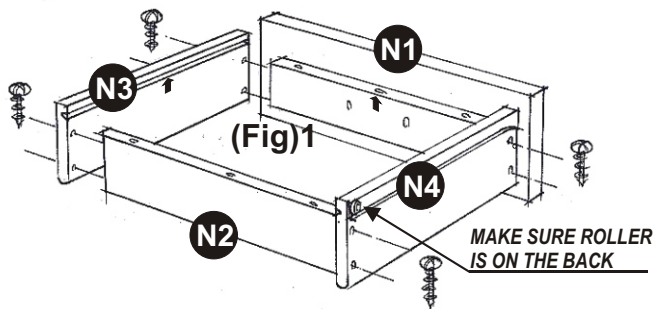

(Fig 1)

Line up Side Parts (N3) and (N4) to the Front Part (N1) and Back Part (N2). Be sure to follow the 'Arrow' sign sticker on the parts. Using a **Phillip's** screwdriver, insert 1" screws into each of the 4 pre-drilled holes on the side of (N3) and (N4), then tighten half way.

(Fig 2)

Turn the assembled drawer over and slide the Plywood Base Part (N5) into the grooves on Side Parts (N3) and (N4). Be sure to push the plywood all the way forward so it meets the Front Part (N1).

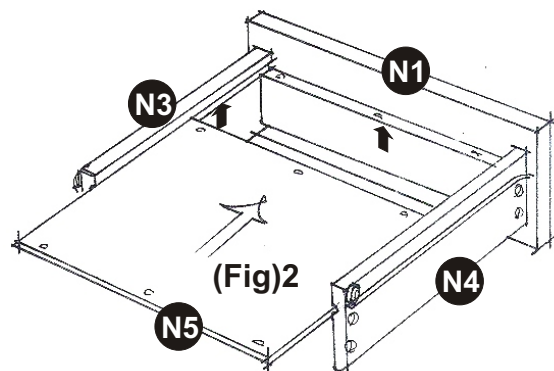

(Fig 3)

Insert the remaining (6) 1/2" screws into the pre-drilled holes in Base Part (N5), then tighten all screws

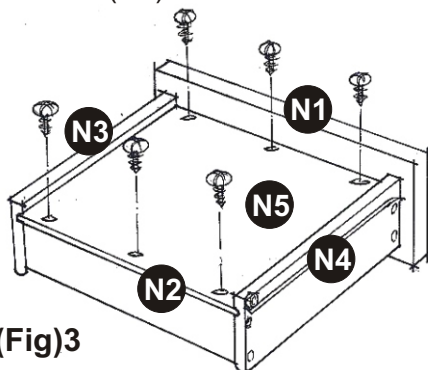

* If you are missing any of these parts, please contact our DMI Customer Service Department at 1-877-831-0319 or fax us at 1-800-755-2878.

(Fig 4)

Assemble the Pull Handle with Machine Screw on the Front Part (N1).

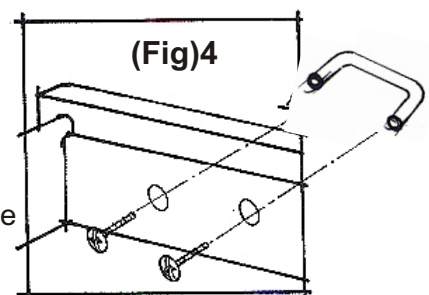

88508695 C Drawer (O)

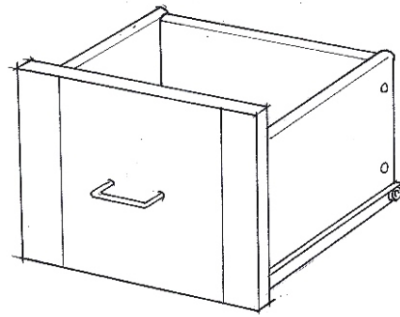

Unit Part List

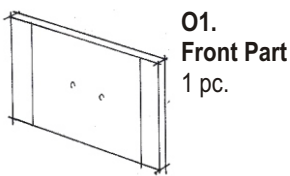

01.
Front Part
1 pc.



02.
Back Part
1 pc.

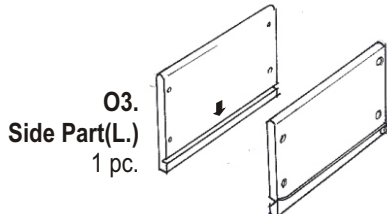

03.
Side Part(L.)
1 pc.

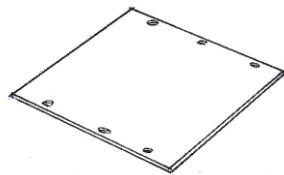

04.
Side Part(R.)
1 pc.

05.
Base Part
1 pc.

HARDWARE LIST

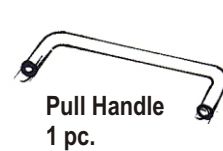

Pull Handle
1 pc.



Wood Screw $\frac{1}{2}$ "
(for Bottom Part)
6 pcs.(+1 Extra)



Machine Screw
for Pull Handle
2 pcs.



Wood Screw 1"
(for Side Part)
8 pcs.(+1 Extra)

Assembly Instructions

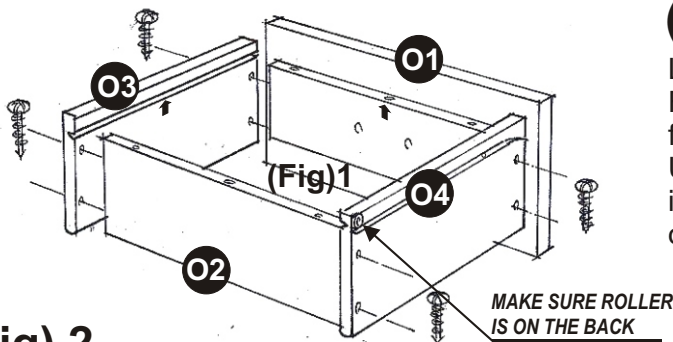

(Fig) 1

Line up Side Parts (O3) and (O4) to the Front Part (O1) and Back Part (O2). Be sure to follow the 'Arrow' sign sticker on the parts. Using a **Phillip's** screwdriver, insert 1" screws into each of the 4 pre-drilled holes on the side of (O3) and (O4), then tighten half way.

(Fig) 2

Turn the assembled drawer over and slide the Plywood Base Part (O5) into the grooves on Side Parts (O3) and (O4). Be sure to push the plywood all the way forward so it meets the Front Part (O1).

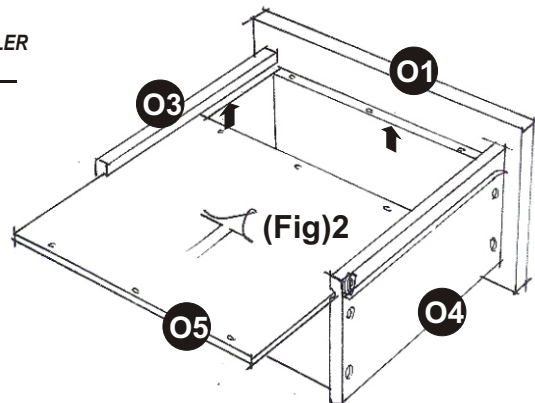

(Fig) 3

Insert the remaining (6) $\frac{1}{2}$ " screws into the pre-drilled holes in Base Part (O5), then tighten all screws

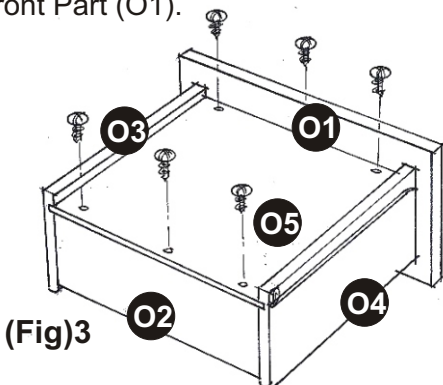

(Fig) 3

* If you are missing any of these parts, please contact our DMI Customer Service Department at 1-877-831-0319 or fax us at 1-800-755-2878.

(Fig) 4

Assemble the Pull Handle with Machine Screw on the Front Part(O1).

