

**“TO BE REMOVED FOR USE BY THE OCCUPANT.”**

Jason International, Inc.  
8328 MacArthur Drive  
North Little Rock, AR 72118  
www.jasoninternational.com



49-1013-100  
Date 02/11

## OWNER'S MANUAL

# Integrity® Whirlpool Baths INSTALLATION, OPERATION, AND MAINTENANCE



**If the carton shows sign of damage, inspect the product before accepting and describe the problem on the Bill of Lading.**

### INSPECTION

**Inspect the unit prior to installation. In the event of a problem, DO NOT install the unit.** All components are factory assembled to the bath and the unit is water tested and inspected prior to leaving Jason International, Inc.

If the carton shows sign of damage, inspect the product before accepting and describe the problem on the Bill of Lading.

**Note:** Transportation and insurance from Jason's factory are the buyer's responsibility.

**Damage sustained in transit is the responsibility of the carrier.** If damage is discovered, the carrier must be immediately notified in writing with a request for a representative to inspect the unit. Failure of the carrier to respond should be reported to the seller and carrier. Always file a freight claim promptly.

The installer is responsible for insuring that the unit is free from defects or shipping damage. In the event of a problem, DO NOT install the unit. Jason International is not responsible

for damage that might have been avoided by inspection or testing prior to installation.

Damage to the unit during installation will not be covered by warranty and is the responsibility of the installer. **ALL WARRANTY CLAIMS ON ACRYLIC SURFACE DAMAGE MUST BE MADE PRIOR TO INSTALLATION.** Inspect plumbing and bath surface for missing or damaged components. Alert your dealer of any discrepancies.

To protect the unit from damage keep the bath in the carton until ready for installation.

### EQUIPMENT ACCESS

In accordance with Building Codes, service access to all therapy bath equipment, controls and electrical connections must be provided during installation (see **Table 1 – Specifications** for minimum access size). Insufficient access will hinder repair and maintenance. Warranty service will not cover costs of providing equipment access.

Jason offers an optional removable lateral skirt for all rectangular baths. The skirts are available in matching acrylic colors and provide convenient access to bath equipment as well as an excellent finished appearance.

**CAUTION: DO NOT LIFT OR HANDLE THE BATH BY ITS PLUMBING.**



### OWNER'S RECORD

**PLACE SERIAL NUMBER CARD WITH  
PRODUCT CONFIGURATION IN THIS BOX**

Dealer: \_\_\_\_\_

Date Purchased: \_\_\_\_\_

Date Installed: \_\_\_\_\_

Installer: \_\_\_\_\_



# INSTALLATION INSTRUCTIONS

**TABLE 1 - SPECIFICATIONS**  
Integrity Whirlpool

Model	Overall Dimension L x W x H (in.) L x W x H (cm.)	Operating Capacity Gal Liter	Pump HP	Min. Size Access W x H (in.) W x H (cm)	Floor Loading lbs/ft <sup>2</sup> kg/M <sup>2</sup>
A6060	60 x 60 x 20.5	53	1	36 x 17	42.4
	152 x 152 x 52	201		91 x 43	207
B3060 TL	60 x 30 x 20.5	29	1	36 x 17	48.6
	152 x 76 x 52	109		91 x 43	237
B3260 TL	60 x 32 x 20.5	32	1	36 x 17	48.0
	152 x 81 x 52	121		91 x 43	234
B3260 SL/SR	60 x 32 x 20.5	32	1	--	50.5
	152 x 81 x 52	121		--	246
B3660	60 x 36 x 20.5	37	1	36 x 17	46.6
	152 x 91 x 52	140		91 x 43	227
B3660 SL/SR	60 x 36 x 20.5	37	1	--	48.8
	152 x 91 x 52	140		--	238
B3666	66 x 36 x 20.5	39	1	36 x 17	44.2
	168 x 91 x 52	147		91 x 43	215
B3672	72 x 36 x 20.5	45	1	36 x 17	44.6
	183 x 91 x 52	170		91 x 43	217
B3672 SL/SR	72 x 36 x 20.5	45	1	--	45.9
	183 x 91 x 52	170		--	224
B4260	60 x 42 x 20.5	44	1	36 x 17	44.7
	152 x 107 x 52	166		91 x 43	218
B4260 SL/SR	60 x 42 x 20.5	44	1	36 x 17	45.9
	152 x 107 x 52	166		91 x 43	224
B4272	72 x 42 x 20.5	49	1	36 x 17	40.5
	183 x 107 x 52	185		91 x 43	197
B4272 SL/SR	72 x 42 x 20.5	49	1	--	41.5
	183 x 107 x 52	185		--	202
C6060	60 x 60 x 20.5	54	1	36 x 17	42.0
	152 x 152 x 52	204		91 x 43	205
D3260	60 x 32 x 20.5	36	1	36 x 17	52.1
	152 x 81 x 52	136		91 x 43	254
J4260	60 x 42 x 20.5	43	1	36 x 17	36.3
	152 x 107 x 52	162		91 x 43	177
J4266	66 x 42 x 20.5	46	1	36 x 17	41.9
	168 x 107 x 52	174		91 x 43	204
J4272	72 x 42 x 20.5	49	1	36 x 17	33.2
	183 x 107 x 52	185		91 x 43	162
L4872	72 x 48 x 20.5	56	1	36 x 17	38.7
	183 x 122 x 52			91 x 43	188

**TABLE 1 - SPECIFICATIONS (cont.)**  
Integrity Whirlpool

Model	Overall Dimension L x W x H (in.) L x W x H (cm.)	Operating Capacity Gal Liter	Pump HP	Min. Size Access W x H (in.) W x H (cm)	Floor Loading lbs/ft <sup>2</sup> kg/M <sup>2</sup>
K3060	60 x 30 x 20.5	38	1	36 x 17	56.8
	152 x 76 x 52	144		91 x 43	277
K3060 TL	60 x 30 x 20.5	38	1	36 x 17	57.0
	152 x 76 x 52	144		91 x 43	278
K3060 SL/SR	60 x 30 x 20.5	38	1	--	58.8
	152 x 76 x 52	144		--	287
K3260	60 x 32 x 20.5	39	1	36 x 17	54.1
	152 x 81 x 52	148		91 x 43	264
K3260 TL	60 x 32 x 20.5	39	1	36 x 17	54.3
	152 x 81 x 52	148		91 x 43	265
K3260 SL/SR	60 x 32 x 20.5	39	1	--	56.0
	152 x 81 x 52	148		--	273
K3666	66 x 36 x 20.5	48	1	36 x 17	49.8
	168 x 91 x 52	181		91 x 43	243
K3666 TL	66 x 36 x 20.5	48	1	36 x 17	50.0
	168 x 91 x 52	181		91 x 43	244
K3666 SL/SR	66 x 36 x 20.5	48	1	--	51.4
	168 x 91 x 52	181		--	251
N3660	60 x 36 x 20.5	44	1	36 x 17	57.1
	152 x 91 x 52	166		91 x 43	278
N4260	60 x 42 x 20.5	49	1	36 x 17	48.1
	152 x 107 x 52	185		91 x 43	234
N4272	72 x 42 x 20.5	52	1	36 x 17	46.3
	183 x 107 x 52	196		91 x 43	226
V4266	66 x 42 x 20.5	43	1	36 x 17	43.9
	168 x 107 x 52	162		91 x 43	214
V4272	72 x 42 x 20.5	46	1	36 x 17	42.3
	183 x 107 x 52	174		91 x 43	206
W4266	66 x 42 x 20.5	40	1	36 x 17	42.1
	168 x 107 x 52	151		91 x 43	205

**INSTALLATION**

See the **USER MAINTENANCE INSTRUCTIONS** section of this owner’s manual, prior to installation, for humidity and mold prevention suggestions.

1. **Finish Frame:** A finish frame under the shell rim should also always be constructed to support the bath deck and insure proper drainage toward the bath well. This frame is not intended to support the full bath weight (**see Figures 1 & 2**).

Jason offers a removable lateral skirt for most baths. The skirts are available in matching acrylic colors and provide convenient access to bath equipment as well as an excellent finished appearance. However, if Jason’s lateral skirt is not used, an access panel **MUST** be provided to enable final electrical connections and service. Please refer to the minimum recommended access panel size in **Table 1 - Specifications**.

If a Jason lateral skirt is to be used, the bath deck must be leveled at 20.5” (52cm) from the support floor or the skirt will not fit properly.

**CAUTION: Make sure the support frame is drilled and/or notched as needed to assure that the ON/Off air actuator switch and air tube are not bound or pinched.**

**Allow ample clearance for the pump.** Whirlpools with optional front pump mounts may require a minimum of 1” clearance beyond the front and pump side lip of the bath to allow clearance of the pump.

**CAUTION: Ambient temperature under the bath where the pump and electronics are installed must not exceed 122°F (50°C).**

2. 100% Silicone with mildew resistant properties should be applied between the water resistant backer board and the deck of the bath. **NOTE:** If you use a tile flange kit, modify the framing to support the bath lip as shown in **Figure 1**.
3. Install the drain and overflow assembly to the bath shell according to the instructions provided with the drain and position the bath in the area of intended installation.

**Figure 1**

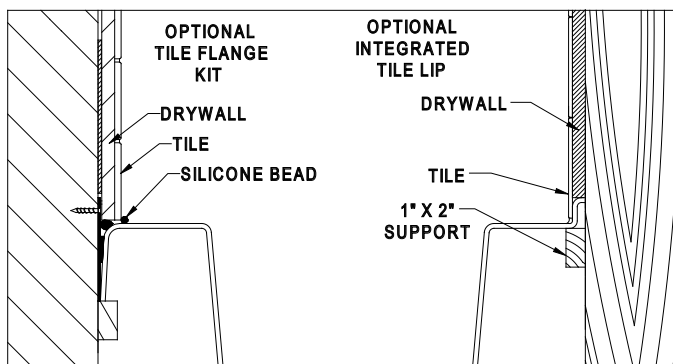

4. Finish plumbing rough-in of drain and overflow assembly. At this time, considerations should be made for the position and mounting of the faucet set, as well as all related plumbing.

5. **Remove the packing board before installing the bath.** The bath is equipped with separate bath equipment support bases which are joined for shipment with packing boards. Detach the packing board from the bath and from underneath the equipment.

**WARNING: Any modification to the equipment is not recommended and will void the Manufacturer’s warranty.**

6. **Install the bath level for proper drainage.** Jason baths are designed to be supported at the base of the bath. If the floor is smooth and level, the baths’ Level Form™ Base will provide proper drainage and support (**See Figure 3**).

7. Mortar is required when the subfloor is not smooth and level; when additional sound insulation is desired; or when the bath is installed in a drop-in application. In alcove installations, a bed of mortar may also be recommended to aid in leveling the bath. **Note:** Do not use a sand bed to install or level the bath.

8. **Secure the bottom of all equipment mounts so that it is level with the bottom of the bath.** Position the bath in the area of intended installation and cut the equipment support strap(s) to allow the equipment to rest firmly on the floor. We recommend securing the equipment mounts to the floor with removable fasteners for ease of servicing.

9. **Protect the acrylic bath surface from damage during installation with a suitable material, i.e., cardboard and/or plastic film.** The acrylic surface of this bath has been provided with a protective film which helps protect the bath during shipment and installation. Additional protection may also be required to protect the acrylic surface during installation. If the bath is tiled in, remove the necessary portion of the film when installing the tile.

**Figure 2**

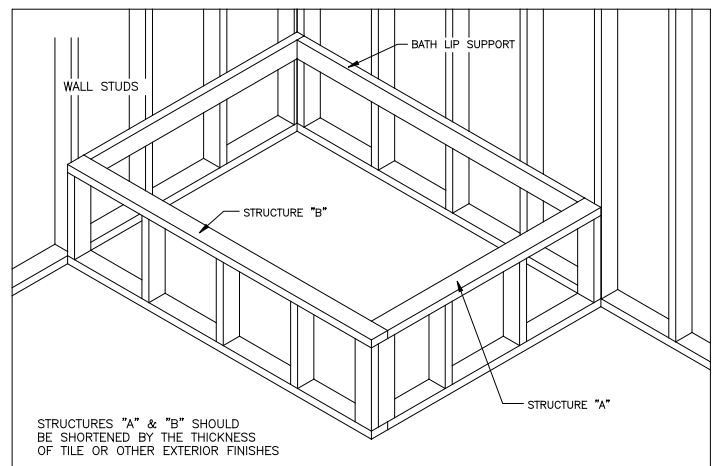
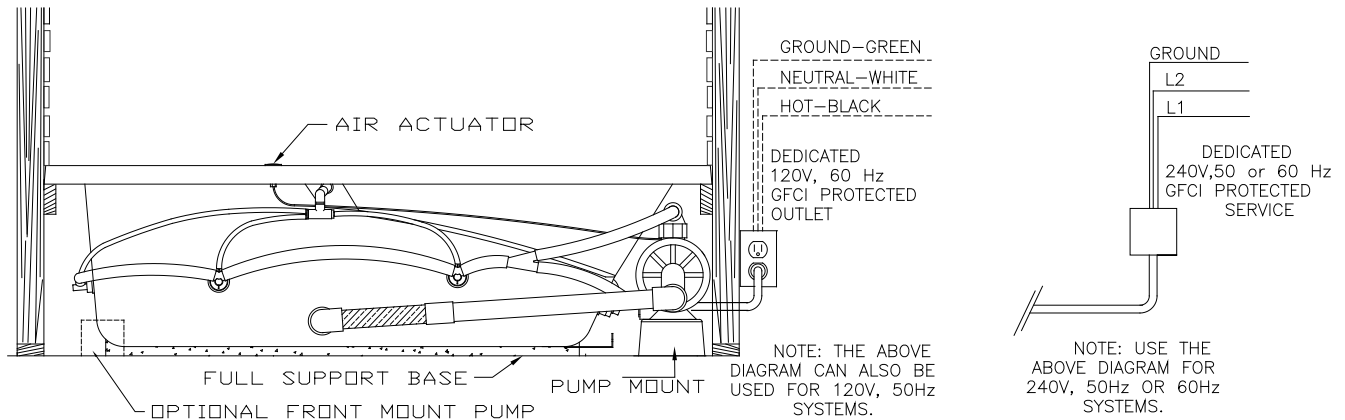

Figure 3



**ELECTRICAL**

**Electrical Power Supply:** These instructions are written assuming 60Hz, 120v power supply. Special notations are also included for export versions of the pump, control equipment, and power supply.

**WARNING: Verification of electrical requirements MUST be made before installation. Refer to the equipment labels for voltage and frequency requirements.**

**NOTE:** Verify that the electrical service matches either the 120v or 240v system requirements for this bath.

**NOTE:** The bath is designed for indoor use only. The electrical equipment must not be exposed to direct or indirect water or moisture contact. The electrical equipment must also be protected from dust and other airborne debris before, during, and after installation.

- 1. Electrical Service:** A licensed electrician must provide the “dedicated” electrical service protected by a GFCI. The location of the GFCI must be at least five (5) feet (152 cm) away from the inside surface of the bath, accessible for regular testing. Use copper conductors only.

**DANGER — RISK OF ELECTRIC SHOCK:** Connect only to a circuit protected by a Ground Fault Circuit Interrupter (GFCI). In the unlikely occurrence of a current imbalance in the power conductors, the GFCI will interrupt the power to the bath.

**WARNING:** The electrical service to the GFCI must not be interrupted by any control device. Likewise, the electrical

service from the GFCI to the bath control should be direct and not interrupted by a switch. Never use a switch in conjunction with a control device. **This will VOID THE MANUFACTURER’S WARRANTY.**

**2. GROUNDING IS REQUIRED**

The unit should be installed by a qualified service representative and properly grounded.

**3. INSTALL SERVICE CONNECTION AT LEAST 6” (15cm) ABOVE SUB FLOOR.**

**ALL LOCAL AND STATE ELECTRICAL AND PLUMBING CODES MUST BE OBSERVED.** Where there are no local codes the **National Electric Code (NEC)** and **Uniform Plumbing Code (UPC)** shall be observed. It is the responsibility of the installer/owner to determine specific code compliance prior to installation of the product.

**NOTE:** In the Commonwealth of Massachusetts, installation is to be done by a Massachusetts licensed plumber.

- 4. Integrity Whirlpool Control Box (120v,60Hz):** This Whirlpool bath is provided with an Air On/Off switch. The pump is pre-wired to a control box which has a 36” cord. Connect the pump to a GFCI (Ground Fault Circuit Interrupter) with 120v (volt), 20A (amp), 60HZ (hertz) electrical service with a service ground receptacle dedicated for use by this bath.

- 5. Export Integrity Whirlpool Control Box (240v,60Hz):** This Whirlpool bath is provided with an Air On/Off switch. The pump is pre-wired to a control box which has a 36”

cord. Connect the pump to a GFCI (Ground Fault Circuit Interrupter) with 240v (volt), 15A (amp), 60HZ (hertz) electrical service with a service ground receptacle dedicated for use by this bath.

**6. Export Integrity Whirlpool Control Box (120v,50Hz):**

This Whirlpool bath is provided with an Air On/Off switch. The pump is pre-wired to a control box which has a 36" cord. Connect the pump to a GFCI (Ground Fault Circuit Interrupter) with 120v (volt), 20A (amp), 50HZ (hertz) electrical service with a service ground receptacle dedicated for use by this bath.

**7. Export Integrity Whirlpool Control Box (240v,50Hz):**

This Whirlpool bath is provided with an Air On/Off switch. The pump is pre-wired to a control box which has a 36" cord. Connect the pump to a GFCI (Ground Fault Circuit Interrupter) with 240v (volt), 15A (amp), 50HZ (hertz) electrical service with a service ground receptacle dedicated for use by this bath.

**DANGER: Do not alter the factory installed wiring.**

All building materials and wiring should be routed away from the pump or other heat-producing components of the unit.

## CLEANING

1. **Remove all loose debris.** Construction plaster or excess grout can be removed with the use of a wood (edge) trowel.
2. **Paint or tar stains** may need to be removed with a cleaner such as paint thinner, turpentine, or isopropyl alcohol (rubbing alcohol). Never allow the cleaner to soak against the acrylic surface for long periods of time. **Always rinse the surface immediately following the use of cleaners.**
3. Follow the manufacturer's instructions for safe use of cleaning products. If the surface becomes scratched or dulled, it may be restored by using a quality plastic polish, like Novus Plastic Polish No. 2 (available from the Jason Dealer). **It is always preferable to protect the acrylic surface during installation to minimize cleanup and prevent surface damage.**

## WATER TESTING

Before finishing the installation, it is recommended that the bath be water tested and the plumbing tested for leaks.

1. **Before water testing the bath,** make sure any pump unions are hand tight. Do not over tighten or use a pipe wrench. This will damage the unions and cause leaking. If the unit leaks with the unions hand tight, then loosen the unions(s) and check the O-ring seal to ensure it is properly seated.
2. **Fill and operate the bath.** Close the drain and fill the bath with water to at least 10 inches [25 cm] below the bath deck. The inlet temperature should not exceed 104°F (40°C) as this could damage the acrylic surface. Refer to the FILLING AND DRAINING section of this owner's manual for more information.

**NEVER RUN THE WHIRLPOOL PUMP WITHOUT ENOUGH WATER IN THE BATH TO COVER THE JETS.**

3. Before starting the pump, direct the jet nozzles downward to prevent the possibility of water splashing from the bath. Refer to the **OPERATING INSTRUCTIONS, FEATURES, AND CONTROLS** section of this Owner's Manual.
4. **Inspect the plumbing for leaks.**
5. **Turn the equipment Off and then drain the water.** The bath unit and its plumbing are designed to drain after each use whether used as a whirlpool bath, air bath, soaking bath, or when taking a shower.

---

# OPERATING INSTRUCTIONS, FEATURES, AND CONTROLS

## INTRODUCTION

This manual contains all of the information needed for the proper operation of this Integrity® Whirlpool bath. The Whirlpool bath has been designed to provide years of relaxing trouble-free service, provided the unit is maintained and operated in accordance with these instructions.

Thoroughly clean and disinfect the unit as described in the **CLEANING** section of the **USER MAINTENANCE INSTRUCTIONS** section of this owner's manual before its first use and periodically thereafter.

**CAUTION:** Keep hair, towels, and clothing away from the suction fitting whenever the Whirlpool equipment is On. Never operate the equipment with the suction cover off, doing so voids the manufacturer's warranty--it is a safety cover designed to eliminate the potential of hair and body entrapment.

All Jason Integrity® Whirlpool baths are pre-plumbed at the factory with standard equipment. Standard equipment includes five (5) or more directional hydrotherapy jets, and an air actuated On/Off switch.

**WARNING:** Before operating refer to the instructions at the end of this owner's manual pertaining to the risk of fire, electric shock, or injury to persons.

## FILLING AND DRAINING

Close the drain and fill the bath with water at least two (2) inches (50mm) above the jets. The inlet temperature should not exceed 40°C (104°F) as this could damage the acrylic surface.

**CAUTION: NEVER RUN THE WHIRLPOOL PUMP WITHOUT ENOUGH WATER IN THE BATH TO COVER THE JETS.**

Before starting the pump, direct the jet nozzles downward to prevent the possibility of water splashing from the bath. When bath is in use, turn the unit Off before draining the water. The bath unit and its plumbing are designed to drain after each use whether used as a hydrotherapy bath, soaking bath, or just taking a shower.

## AIR ON/OFF BUTTON

The Air On/Off button provides a safe and convenient method for controlling the Whirlpool bath. The Air On/Off button is factory mounted onto the bath prior to shipment. **See Figure 3** for the location of the Air On/Off button (air actuator) on the Whirlpool bath. Fill the bath to at least two (2) inches above the highest jet and press the Air On/Off button to start the whirlpool pump. Press the Air On/Off button again to stop the whirlpool pump.



**NOTE:** If the unit fails to operate, check the breaker panel to insure that the circuit breaker is On. Check the ground fault circuit interrupter (GFCI) by testing and resetting it. If the unit still fails to operate contact an authorized service technician for repair. **DO NOT ATTEMPT TO RESOLVE THE PROBLEM.**

## JETS

Five or more strategically placed whirlpool jets are provided for complete enjoyment of the bath. The jets are specially designed for maximum whirlpool action with direction and flow control. Changing the direction of the jets will concentrate the massaging jet stream to the area of preference and turning the flange of the jet will adjust the amount of flow.

## PUMP

The pump provided on Integrity® Whirlpool baths is factory tested when assembled onto the bath. The pump is designed to incorporate high quality, long-life seals which provide superior service. However, should the pump need service, use the suction and discharge unions provided for easy removal.

---

# USER MAINTENANCE INSTRUCTIONS

## HUMIDITY

**Warning: Avoid high humidity levels in your home. Mold, mildew, fungi and bacteria which may be harmful to health thrive in areas with continued high humidity levels; therefore, every precaution should be taken to make sure your plumbing fixtures including bathtubs, therapy baths, or showers do not become a source of high humidity due to improper installations or leaks.**

To avoid having your plumbing fixtures become a source of unwanted humidity, please make sure the following steps are taken prior to installation.

1. Make sure the area where the bathtub or shower is installed is well vented and allows enough ventilation and air circulation to dry the bathroom environment within a short time after taking a bath or shower.
2. If your bath or shower unit is tiled-in, use units with an integral tile flange or make sure a tile flange kit or a similar mechanical barrier is installed to prevent shower spray, splash, or overflow to leak behind the bathtub.
3. Make sure the plumber properly tests your therapy bath before it is roughed in to make sure there are no leaks and it is installed with proper access to bath equipment.
4. Make sure that all the plumbing and fixtures in the bathroom are in good working order and have no leaks.
5. Do not use carpeting or other materials or furniture, which can hold moisture in your bathroom.
6. Use disinfectant to clean any bathroom surfaces which are regularly exposed to moisture.
7. Clean and disinfect humidifier and dehumidifiers as recommended by the manufacturer. Replace the air filter on the HVAC unit once a month.
8. Clean moldy surfaces as soon as any mold appears by using a detergent/soapy solution and appropriate household cleaner. Always use gloves during cleaning. Dispose of any sponges or rags used to clean mold.

## CLEANING

With minimum care, your acrylic-surfaced bath will retain its high-luster finish for many years. For regular cleaning use Jason Bath Cleaner or a mild **NONABRASIVE** liquid detergent solution (i.e. glass cleaner) and a soft, wet cloth or sponge. Do not run the air system with foaming cleaners or soaps. Rinse the bath thoroughly after cleaning.

## SURFACE MAINTENANCE

Areas with minor scratches or dull surfaces can be restored by applying commercially available plastic polish (i.e. Novus Plastic Polish No. 2, available at your Jason dealer), followed by an application of acrylic paste wax. Buff the surface with a clean soft cloth. Do not use sandpaper, steel wool, or abrasive rubbing compounds.

If scratches are too deep to rub out, or if the damage penetrates the acrylic surface, consult your dealer for recommendations on surface repair.

## FLUSHING / SANITIZING

**Upon start-up and not to exceed 90 days thereafter, flush the Whirlpool bath and plumbing system** with Jason's Bath System Cleaner, available at Jason Dealers, or use an equivalent cleaner. Follow the cleaning instructions below:

1. Close the bath drain and open the air controls.
2. Fill the bath with warm water to a level at least 2" (5 cm) above the highest jet.
3. Pour 16 ounces of Jason's Bath System Cleaner into the bath water.
4. Turn on the whirlpool pump for 10 minutes.
5. Turn off the pump and drain the bath.
6. To rinse, refill the bath with cold water, turn on the pump for five minutes, then turn off the pump and drain the bath.

**Note:** The bath can be sanitized after each bather without harming the whirlpool bath plumbing.

## REPAIR

Refer all plumbing or electrical repair to a qualified service technician. **DO NOT ATTEMPT TO RESOLVE THE PROBLEM. This can result in danger of electrical shock or damage to the unit and will VOID THE WARRANTY.** Remember, when contacting your dealer or service representative, always have your serial number, proof of purchase, and model number. This will insure a quick response on warranty items. The serial number can be found on the front page of this manual or on the small card adhered to the back of the bath just above the pump.

**ALL WARRANTY REPAIRS MUST BE AUTHORIZED BY THE MANUFACTURER BEFORE WORK IS STARTED.**

# TROUBLE SHOOTING GUIDE

If the unit is within the warranty period, contact **Jason Customer Service: 1-800-255-5766** with the bath's Product and Serial numbers before work is started. The serial number can be found on the front page of this manual or on the small card adhered to the back of the bath just above the pump.

**ALL WARRANTY REPAIRS MUST BE AUTHORIZED BY JASON INTERNATIONAL BEFORE WORK IS STARTED.**

**FOR SERVICE, ALWAYS CONTACT THE DEALER OR AUTHORIZED SERVICE CENTER**

**WARNING:** Always turn off power at the main electrical service panel when servicing the bath.

SYMPTOMS	POSSIBLE CAUSES	RECOMMENDED ACTION
Whirlpool system fails to operate.	a) No power to the whirlpool unit.	a) Reset circuit breakers or replace fuses. Check GFCI and reset if tripped.
	b) Not wired correctly.	b) Make sure power supply is correctly wired into the unit.
	c) Air switch — plastic air tube disconnected or broken.	c) Check, reconnect, or replace tubing as necessary.
Pump operates, but no air is injected into the water.	a) Air valve(s) closed.	a) Open air control valve(s).
	b) Line is clogged.	b) Contact installer/dealer.
Pump operates, but water is not being pumped.	a) Insufficient water level.	a) Fill bath to recommended level. Water must be at least two (2) inches above the jets.
	b) Suction or discharge blocked.	b) Remove obstruction.
	c) Suction air leak. ( <i>System usually surges.</i> )	c) Make sure union is tight on suction side of pump.
Pump runs, but jets will not operate.	a) Jets are completely or partially closed.	a) Adjust jets by rotating outer flange.
Pump does not manually shut off.	a) Air switch tube disconnected or broken.	a) Reconnect or replace plastic air tube.
Pump unions leak.	a) Unions undertightened, overtightened, cracked or O-ring is not seated properly ( <i>possibly pinched</i> ).	a) Back off union nut, check and straighten O-ring, replace as necessary, retighten. <b>HAND TIGHTEN ONLY!</b>
Pump shuts off by itself.	a) Insufficient water	a) Make sure bath is filled to at least 2" above the highest jets.
Pump leaks at shaft.	a) Damaged or defective shaft seal.	a) Contact installer/dealer.
Optional LED light will not operate.	a) Light bulb is loose in the socket.	a) Access light bulb and ensure it is properly installed.

**WARRANTY REGISTRATION: Register your product's warranty online at [www.jasoninternational.com](http://www.jasoninternational.com).**

### JASON INTERNATIONAL INC. LIMITED WARRANTY

The Company warrants the products of its own manufacture to be free from defects in workmanship and material for a period of twelve (12) months from date of installation or eighteen (18) months from date of manufacture, whichever comes first. Any merchandise which upon Company examination proves to be defective under normal use and service during the warranty period will be at the Company's option repaired, replaced or credit issued in the amount of the invoice value of the defective merchandise. All other types of remedies are excluded. This warranty extends only to the owner of the originally installed merchandise. The Company is not responsible for labor or other installation costs for the repair or replacement of defective merchandise. Company reserves the right to substitute new or improved equipment on any replacements. The repair or replacement of equipment shall be F.O.B. point of shipment.

This warranty shall not apply to any merchandise which has been subject to accident, alteration, abuse, misuse, abrasives, corrosion and/or electrolysis, improper voltage supply, misapplication, careless handling, improper installation, maintenance, abnormal chemical conditions, nor does this warranty cover stains, discoloration or the fading of color due to improper use of chemicals or improperly maintained water chemistry.

This warranty shall not apply to any merchandise or parts thereof which were not manufactured by Company. Such product or merchandise manufactured by others shall have only such warranties, in writing, that may be extended and in force at the time by such other manufacturer or supplier.

To obtain warranty service, you must contact the retailer from which the merchandise was purchased or Company's distributor in your area. Written notice of warranty defects must be given to the company within thirty (30) days from the occurrence thereof. Written permission must be obtained by the retailer or distributor from the Company before any equipment claimed defective is returned for inspection.

EXCEPT AS PROVIDED HEREIN, COMPANY MAKES NO WARRANTIES EITHER EXPRESSED OR IMPLIED, AS TO ANY MATTER WHATSOEVER INCLUDING THE CONDITION OF THE MERCHANDISE, ITS MERCHANTABILITY OR FITNESS FOR A PARTICULAR PURPOSE. ANY WARRANTIES IMPLIED BY LAW AND NOT EFFECTIVELY EXCLUDED BY THIS WARRANTY, ARE LIMITED TO THE DURATION AND REMEDIES OF THIS WARRANTY. IN NO EVENT SHALL THE COMPANY BE LIABLE FOR CONSEQUENTIAL OR INCIDENTAL DAMAGES.

Some states do not allow limitations on how long an implied warranty lasts or the exclusion or limitation of incidental or consequential damages, so the above limitations may not apply to you.

This warranty gives you specific legal rights and you may also have other rights that vary from state to state.



# IMPORTANT SAFETY INSTRUCTIONS

## INSTRUCTIONS PERTAINING TO THE RISK OF FIRE, ELECTRIC SHOCK, OR INJURY TO PERSONS.

**WARNING:** When using this unit, basic precautions should always be followed, including the following:

This manual contains information and instructions for proper operation and maintenance of the hydrotherapy bath. Failure to follow these instructions could result in personal injury, electrical shock, or fire.

## READ AND FOLLOW ALL INSTRUCTIONS CAREFULLY

**DANGER:** TO REDUCE THE RISK OF INJURY FOLLOW THESE PRECAUTIONS:

- A. Do not permit children to use this product unless they are closely supervised at all times.
- B. Use this unit only for its intended use as described in this manual. Do not use attachments not recommended by the manufacturer.
- C. The water in a hydrotherapy bath should never exceed 40°C (104°F). Water temperatures between 38°C (100°F) and 40°C (104°F) are considered safe for a healthy adult. Use time should be limited to approximately 30 minutes, followed by a shower to cool down. Longer exposures may result in hyperthermia. The symptoms of this condition are nausea, dizziness, and fainting, and it can be fatal. Lower water temperatures are recommended for extended use (exceeding 10 -15 minutes) and for young children.
- D. Since excessive water temperatures have a high potential for causing fetal damage during the early months of pregnancy, pregnant or possibly pregnant women should limit hydrotherapy bath water temperatures to 38°C (100°F).
- E. The use of drugs or alcoholic beverages before or during hydrotherapy bath use may lead to unconsciousness with the possibility of drowning. Never use the hydrotherapy bath while under the influence of alcohol, anticoagulants, stimulants, antihistamines, vasoconstrictors, vasodilators, hypnotics, narcotics, or tranquilizers.
- F. Persons with a medical history of heart disease, low or high blood pressure, circulatory system problems, or diabetes should consult a physician before using a hydrotherapy bath.
- G. Persons using medication should consult a physician before using a hydrotherapy bath since some medication may induce drowsiness while other medication may affect heart rate, blood pressure, and circulation.

**DANGER:** To reduce the risk of injury, enter and exit the bath slowly.

Do not operate this unit unless the suction cover is attached over the suction inlet fitting and the jet assemblies are installed. There should be at least two (2) inches of water above the highest jet location during whirlpool bath operation. **NEVER RUN UNIT DRY.**

**WARNING:** Never operate electrically connected devices in or near the bath. Never drop or insert any object into any opening.

This unit must be connected to a supply circuit that is protected by a GFCI. Such a device should be installed by a licensed electrician and should be tested on a regular basis (at least monthly). To test the GFCI push the **TEST** button. The GFCI should interrupt the power. Push the **RESET** button and the power should be restored. If the GFCI fails to operate in this manner, there is the possibility of an electric shock. **DO NOT USE.** Disconnect the unit and have the problem corrected by a qualified service technician.

To avoid the possibility of personal injury and discoloration of the acrylic surface, the inlet water temperature should not exceed 40°C (104°F). The bath should be drained after each use. Each bather should start their bath with fresh water. Do not use oil base additives in the hydrotherapy bath.

**CAUTION:** Do not use harsh abrasives or solvents for cleaning this unit.

**INSTALLER/OWNER BEARS ALL RESPONSIBILITY TO COMPLY WITH ALL STATE AND LOCAL CODES WHEN INSTALLING THIS PRODUCT.**

## SAVE THESE INSTRUCTIONS

## JASON INTERNATIONAL, INC.

8328 MacArthur Drive • North Little Rock • Arkansas • 72118

[www.jasoninternational.com](http://www.jasoninternational.com)