

Examine all packaging material for small parts that may have come loose during shipment. Periodic checks are recommended to insure that all components are in proper position, tight and free from damage. Keep this assembly instruction for future reference. Adult assembly required. Online Parts Request: parts.request@hillsidefurniture.com - Customer Service Phone Number: 502-562-0000

HARDWARE LIST

- A (16) Short Allen Bolts
- B (6) Long Allen Bolts
- C (22) Spring Washers
- D (6) Flat Washers
- E (16) Camber Washers
- F (4) Wood Screws
- G (1) Allen Wrench

PARTS LIST

- H (1) Stool Back
- J (1) Seat Base
- K (1) Seat Cushion
- L (1) Stool Base
- M (4) Legs
- N (1) Support Ring

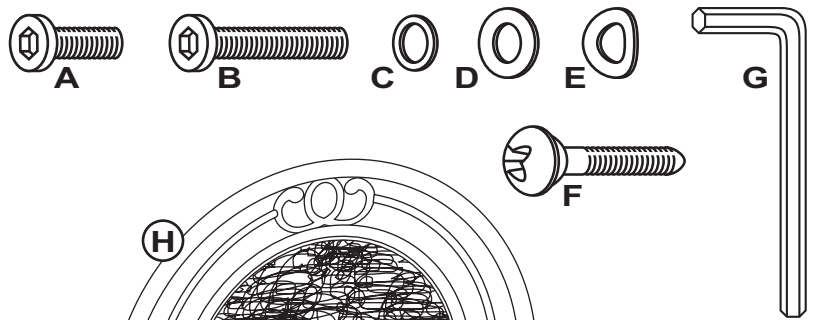

STEP 1

Begin assembly by attaching the Stool Back (H) to the Seat Base (J) by inserting each post into place. Secure in place using 1 Long Allen Bolt (B), 1 Spring Washer (C) & 1 Flat Washer (D) per each side. Tighten all bolts.

STEP 2

Next, attach each Leg (M) to each opening on the bottom of the Stool Base (L) by inserting into place. Secure in place using 2 Short Allen Bolts (A), 2 Spring Washers (C) & 2 Camber Washers (E) per each leg. See Figure A. Do not fully tighten bolts.

FIGURE A

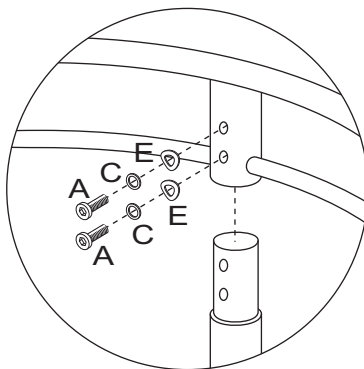

STEP 3

Once in place, attach the Support Ring (N) to each Leg (M) by setting onto metal tab and securing using 2 Short Allen Bolts (A), 2 Spring Washers (C) & 2 Camber Washers (E) per each leg. Tighten all bolts from Steps 2 & 3.

STEP 4

Attach the Seat Base (J) to the Stool Base (L) by attaching the Swivel Metal Plate on the bottom of the Seat Base to the Cross Bars on the Stool Base using 4 Long Allen Bolts (B), 4 Spring Washers (C) & 4 Flat Washers (D) to hold in place. Tighten all bolts.

STEP 5

Finally, attach the Seat Cushion (K) to the Seat Base (J) using 4 Wood Screws (F) to hold in place. Tighten all screws only using a phillips head screwdriver (not included). The assembly is now complete.

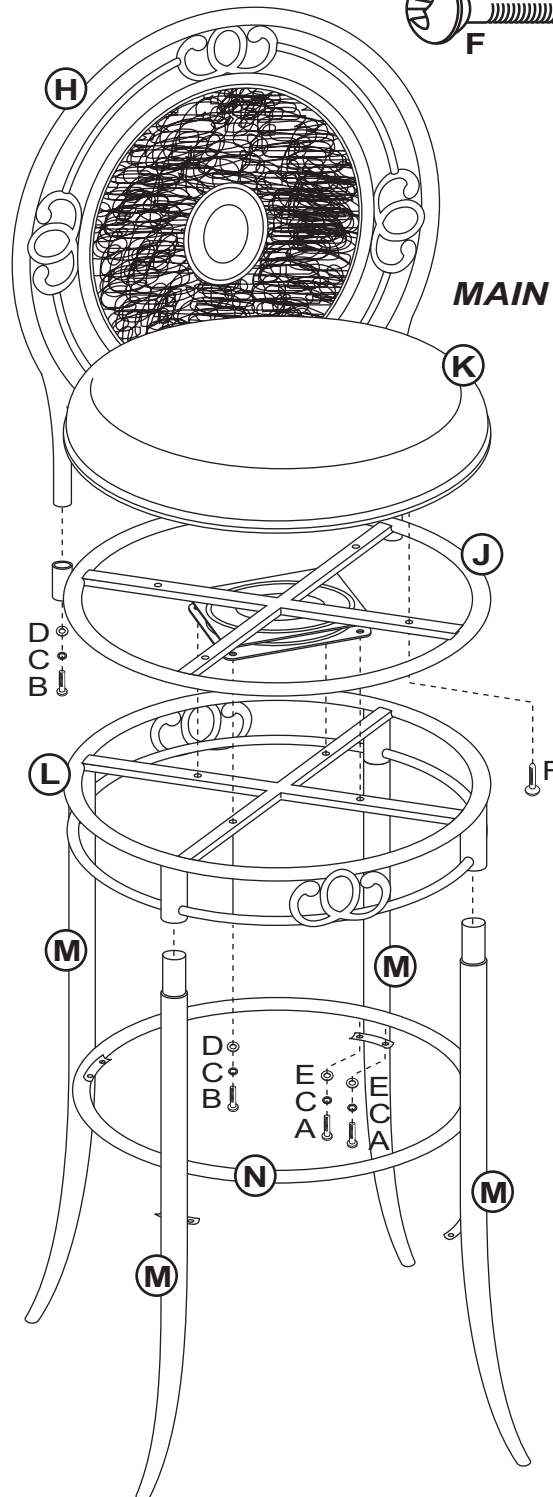

MAIN FIGURE