

Examine all packaging material for small parts that may have come loose during shipment. Periodic checks are recommended to insure that all components are in proper position, tight and free from damage. Keep this assembly instruction for future reference. Adult assembly required. Online Parts Request: parts.request@hillsdalefurniture.com - Customer Service Phone Number: 502-562-0000

HARDWARE LIST

- A (8) Short Allen Bolts
- B (4) Medium Allen Bolts
- C (2) Long Allen Bolts
- D (4) Counter Sunk Bolts
- E (6) Spring Washers
- F (6) Metal Washers
- G (1) Allen Wrench

PARTS LIST

- H (1) Stool Back
- J (1) Stool Base
- K (1) Seat Base
- L (1) Inner Ring
- M (4) Legs

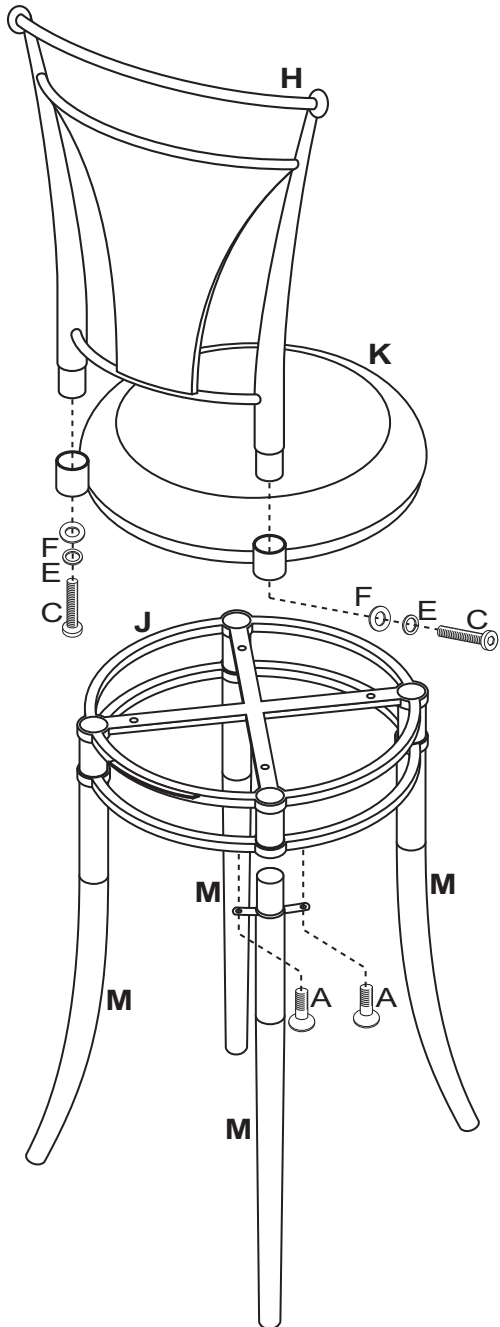
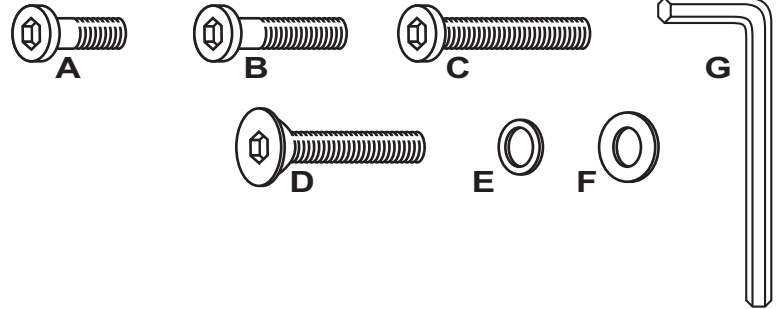

STEP 1

Begin assembly by attaching each Leg (M) to Stool Base (J), from the bottom side, using 2 Short Bolts (A) per each leg. Only hand tighten bolts for this step. See figure at the left.

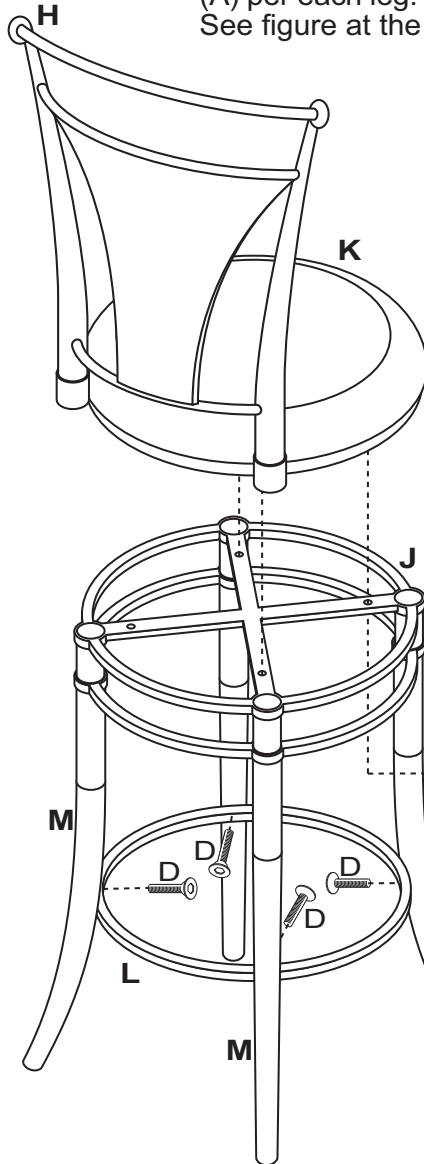

STEP 2

Next, attach Stool Back (H) to Seat Base (K), using 2 Long Allen Bolts (C), 2 Spring Washers (E) & 2 Metal Washers (F) per each side. Only hand tighten bolts for this step. See figure at the left.

STEP 3

Attach Seat Base (K) to Stool Base (J), using 4 Long Allen Bolts (B), 4 Spring Washers (E) & 4 Metal Washers (F) from the bottom side. Only hand tighten bolts for this step. See figure at the left.

STEP 4

Attach Lower Ring (L) to each Leg (M), using 1 Counter Sunk Bolt (D) per each leg. Once each leg is in place, Tighten all bolts from Steps 1 through 4. See Figure at the left. The assembly is now complete.

CARE & MAINTENANCE: The touch of a soft cloth is all the maintenance the finish will ever need. Please do not use harsh or abrasive cleaners for polishing, as they may cause damage to the finish. Periodic checks are recommended to make sure that all bolts, screws and nuts are securely tightened.