

Examine all packaging material for small parts that may have come loose during shipment. Periodic checks are recommended to insure that all components are in proper position, tight and free from damage. Keep this assembly instruction for future reference. Adult assembly is required. Customer Service Phone Number: 502-562-0000

HARDWARE LIST

- A (8) Long Allen Bolts
- B (4) Short Allen Bolts
- C (8) Spring Washers
- D (8) Flat Washers
- E (8) Hex Nuts
- F (1) Open End Wrench
- G (1) Allen Wrench

PARTS LIST

- H (1) Back Panel
- J (1) Left Side Panel
- K (1) Right Side Panel

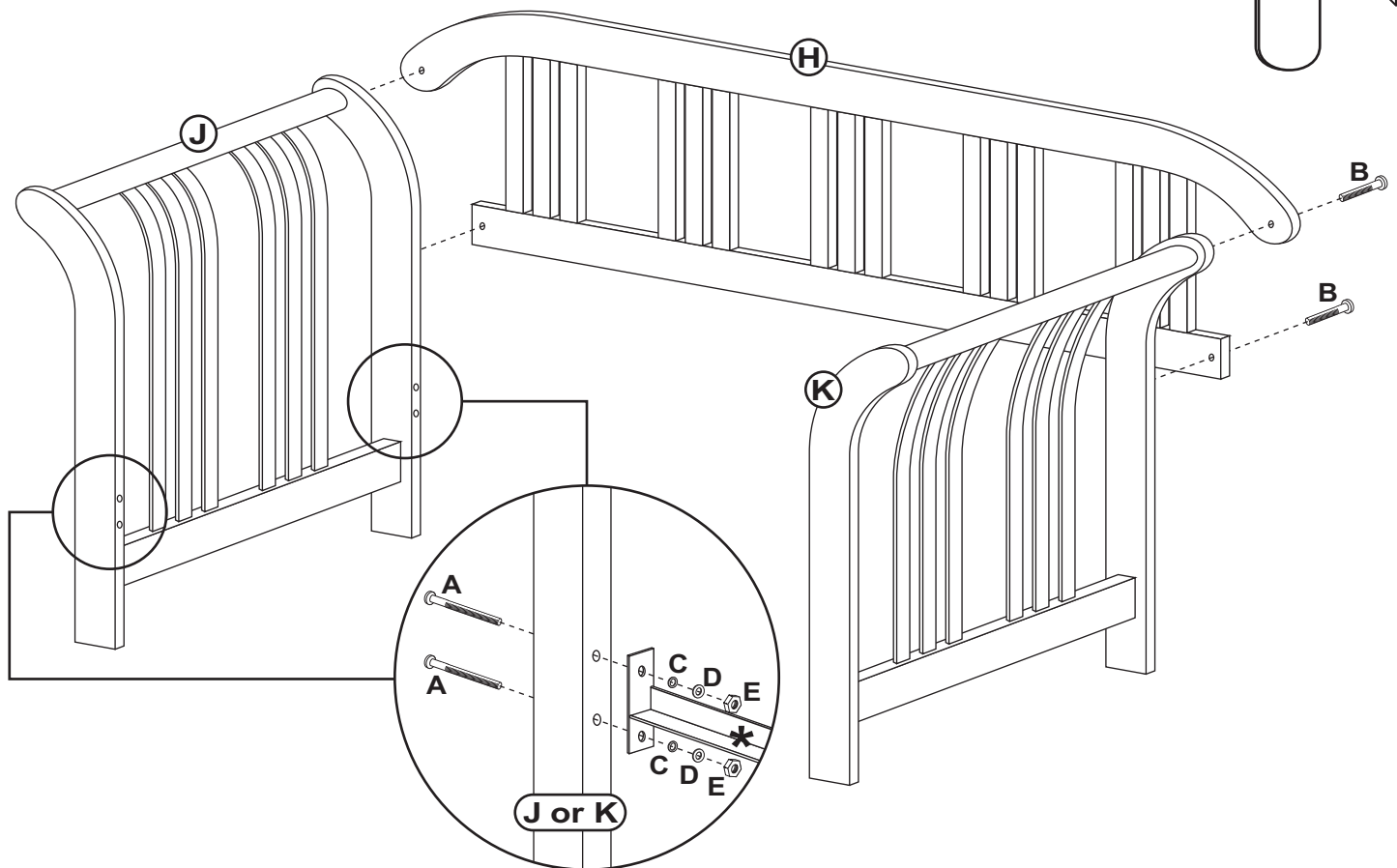
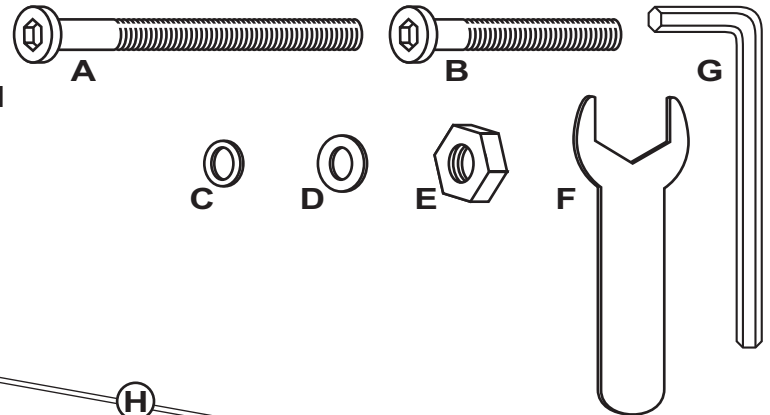

STEP 1

Begin assembly by first attaching Back Panel (H) to each Left and Right Side Panel (J & K) using 2 Short Allen Bolts (B) from the rear side. Tighten all bolts only using the Allen Wrench (G) provided.

STEP 2

Attach Link Spring (*Not Included) to daybed in each corner on legs using 2 Long Allen Bolts (A), 2 Spring Washers (C), 2 Flat Washers (D) & 2 Hex Nuts (E) per each end. Tighten all bolts and nuts only using the Allen and Open End Wrenches (F & G) that have been provided. The assembly of your new daybed is now complete.