

ASSEMBLY INSTRUCTION

91072 (A)

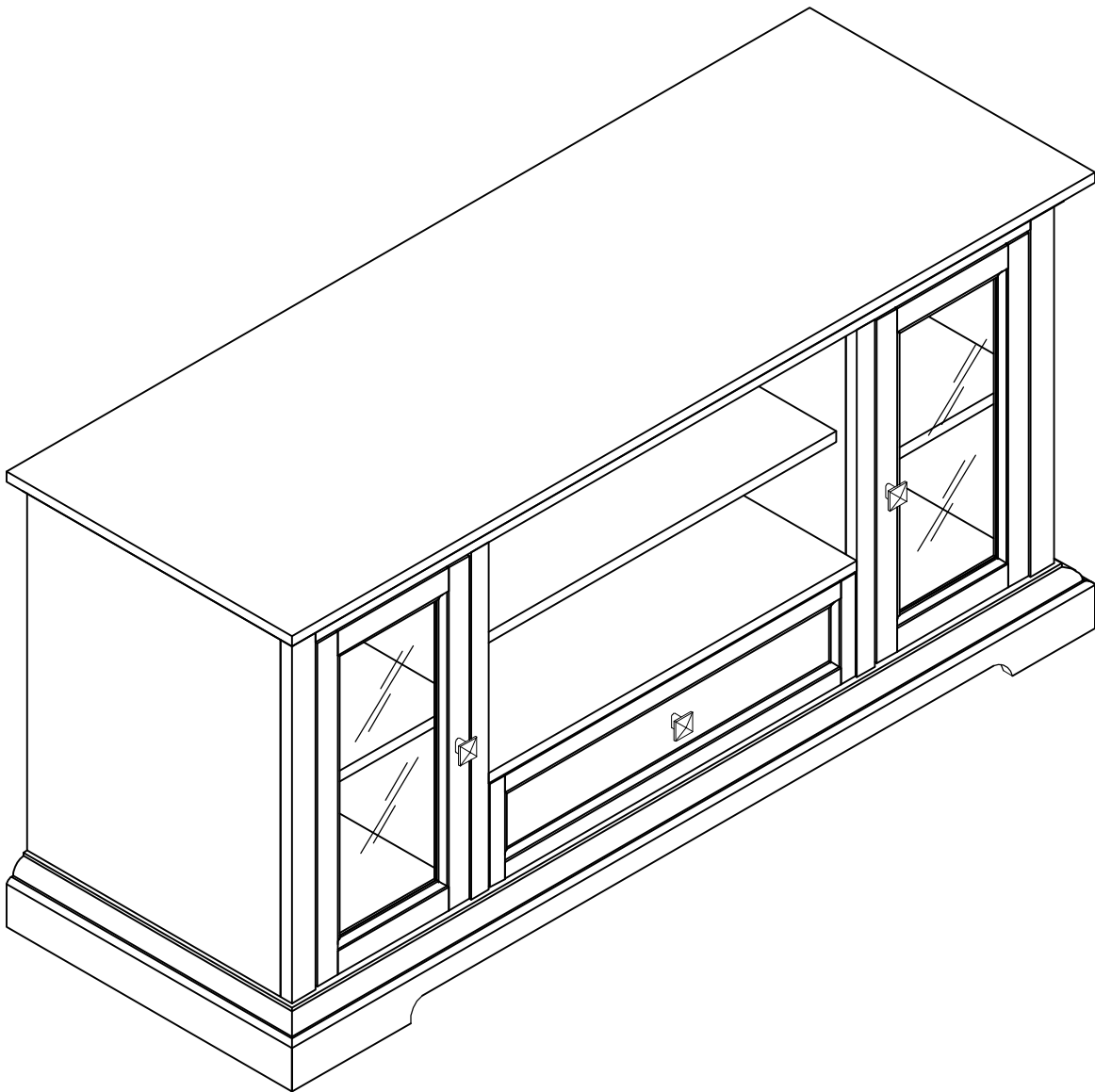

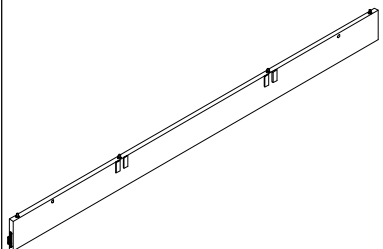
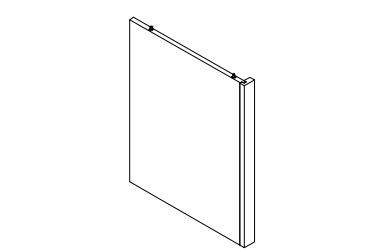
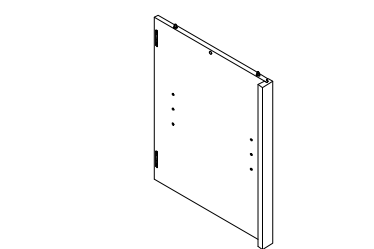
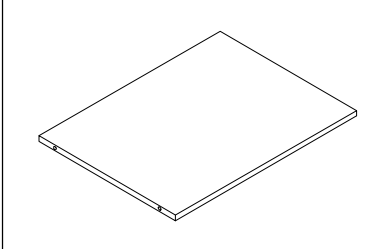
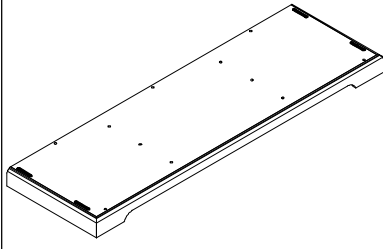
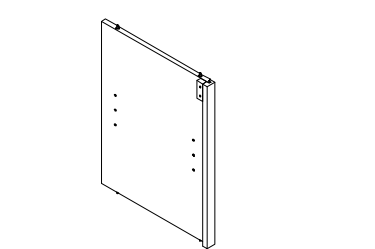
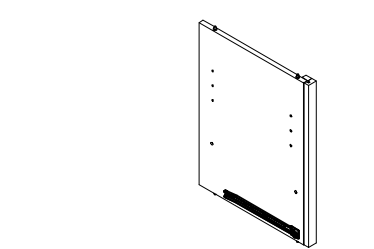
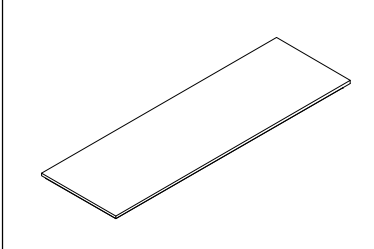
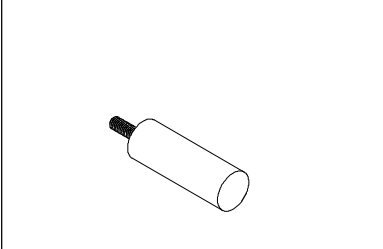
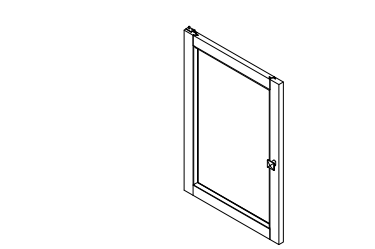
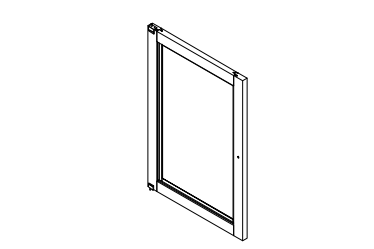
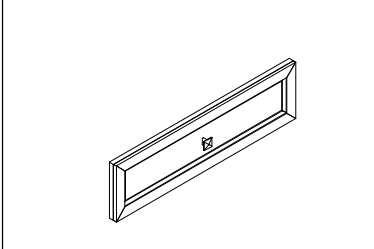
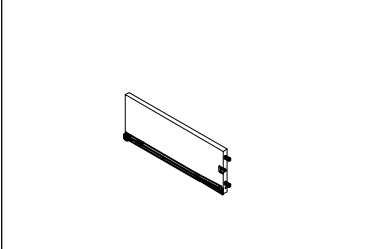
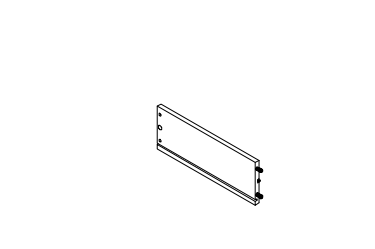
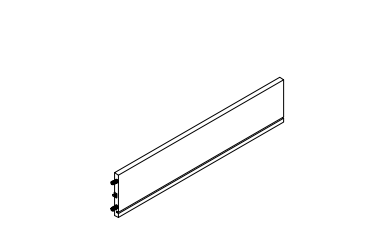
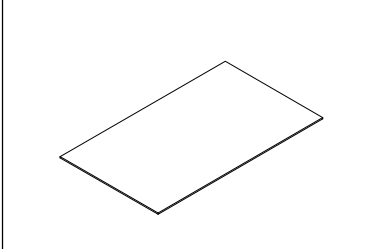
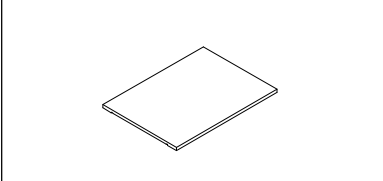
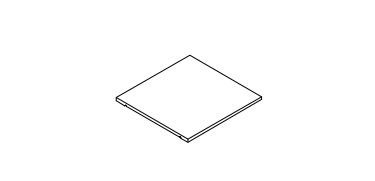
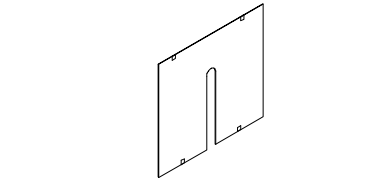
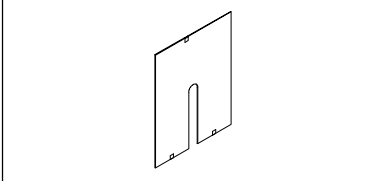
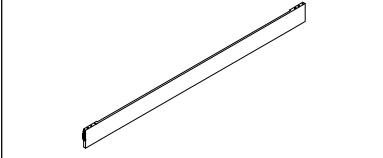
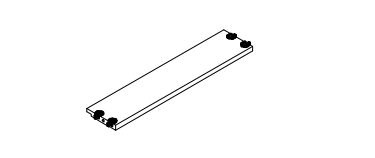

NO TOOLS..

PARTS LIST

1	UPPER BACK APRON	1 PC	2	LEFT SIDE PANEL	1 PC	3	RIGHT SIDE PANEL	1 PC	4	FIXED SHELF	1 PC
											
5	BOTTOM PANEL	1 PC	6	LEFT DIVIDER	1 PC	7	RIGHT DIVIDER	1 PC	8	TOP PANEL	1 PC
											
9	LEG	2 PCS	10	LEFT DOOR	1 PC	11	RIGHT DOOR	1 PC	12	DRAWER FRONT PANEL	1 PC
											
13	DRAWER LEFT SIDE PANEL	1 PC	14	DRAWER RIGHT SIDE PANEL	1 PC	15	DRAWER BACK PANEL	1 PC	16	DRAWER BOTTOM PANEL	1 PC
											
17	MIDDLE ADJUSTABLE SHELF	1 PC	18	SIDE ADJUSTABLE SHELF	2 PCS	19	MIDDLE BACK PANEL	1 PC	20	SIDE BACK PANEL	2 PCS
											
21	LOWER-BACK APRON	1 PC	22	SIDE APRON	2 PCS						
											

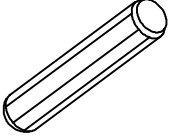
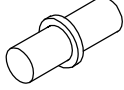
HARDWARE LIST

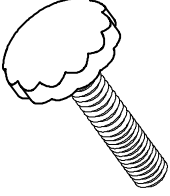
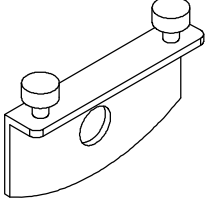
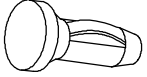
A	WOODEN DOWEL	8 PCS	B	SHELF PIN	12 PCS	C	MAGNET	2 PCS
								
D	THUMBSCREW	3 PCS	E	HALF-MOON SLIDE PARTS	4 PCS	F	PLASTIC PIN	4 PCS
								

LUBRICANT NOT PROVIDED

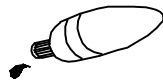

We recommend the use of a lubricant on the key locks for easier assembly. This will allow the hardware to slide together with greater ease. We suggest the use of vaseline or liquid soap as a lubricant. Please be sure to wipe the surfaces clean after the assembly to prevent damage to the board.

If any parts are missing or damaged in this package, circle the item(s) needed to the left on the parts or hardware list. Please be sure to have the model # and color ready when ordering parts.

You can contact us by mail:

Premier RTA

4105 McMinnville Hwy

Sparta, TN 38583

Or fax: (931) 657-5507

Or phone from 7:00A - 3:00P CST: 1-866-782-0515

Or e-mail: parts@blomand.net

NAME:

ADDRESS:

CITY:

STATE:

ZIP CODE:

HOME PHONE:

WORK PHONE:

Step 1

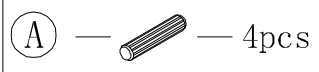

- Insert 2 Wooden Dowels (A) into one end of the Back Side Aprons (#22).
- Align the Back Side Aprons (#22) with the Upper Back Apron (#1). Turn the fittings to lock into place.
- Insert 2 Wooden Dowels (A) into the other end of the Back Side Aprons (#22).
- Align the Lower Back Apron (#21) with the assembly. Turn the fittings to lock into place.

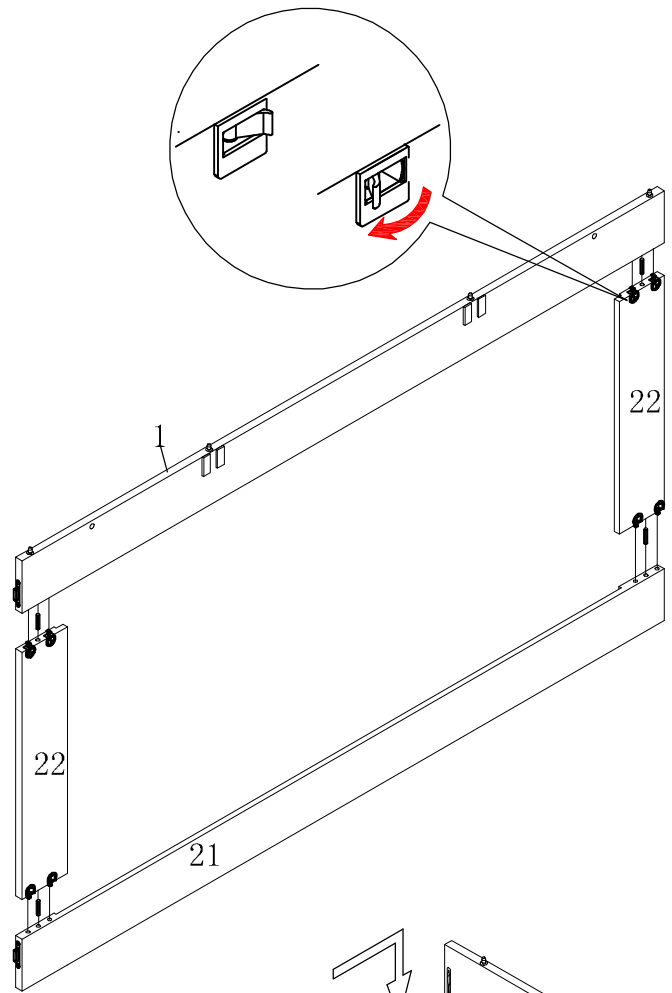

Step 2

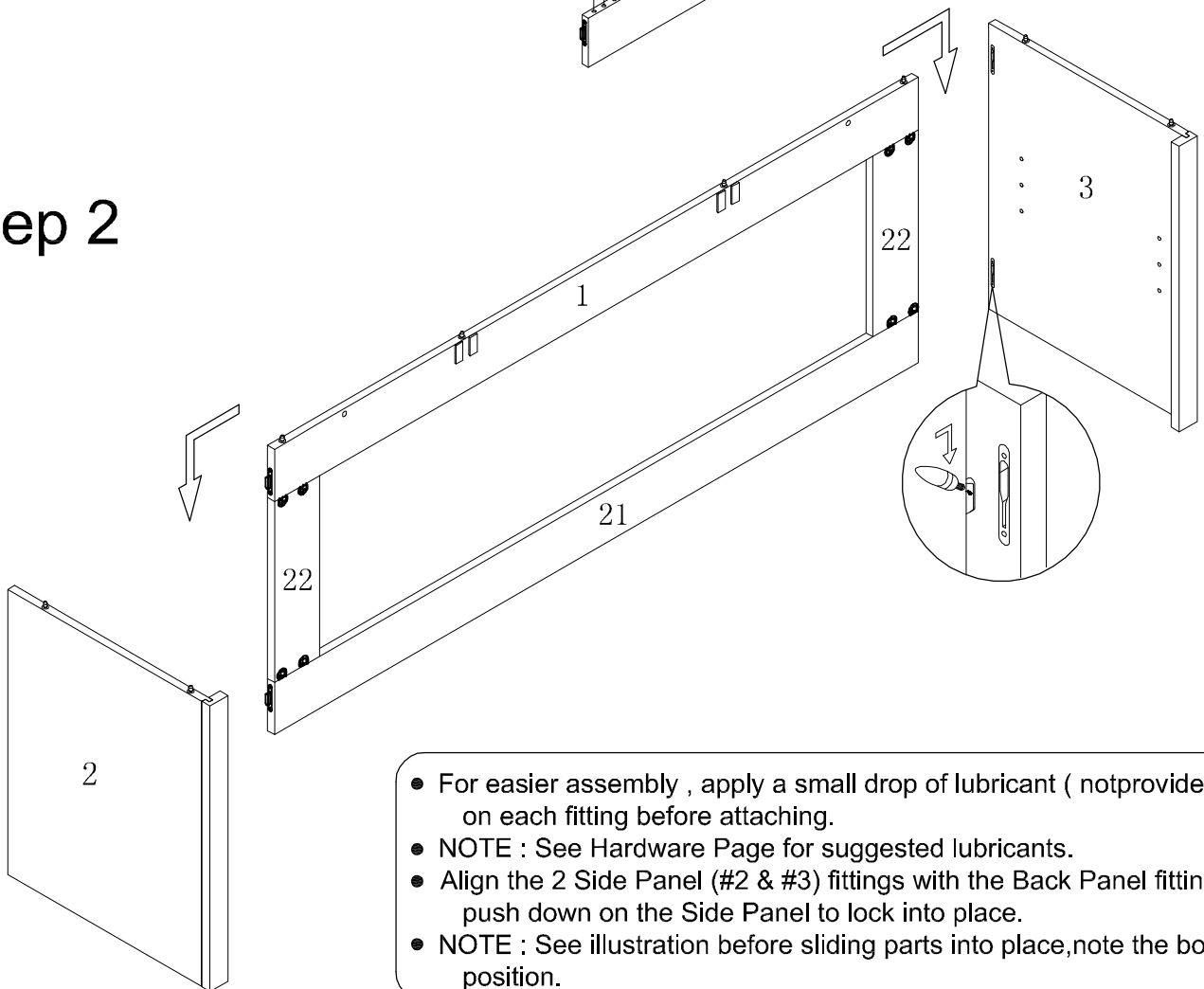

- For easier assembly , apply a small drop of lubricant (notprovided) on each fitting before attaching.
- NOTE : See Hardware Page for suggested lubricants.
- Align the 2 Side Panel (#2 & #3) fittings with the Back Panel fittings; push down on the Side Panel to lock into place.
- NOTE : See illustration before sliding parts into place,note the board position.

Step 3

- Set the Bottom Panel (#5) face up on the floor.
- Carefully lift Back Frame , Left Side Panel , and Right Side Panel assembly onto Bottom Panel.
- Align fittings , push down and slide the side panels forward.

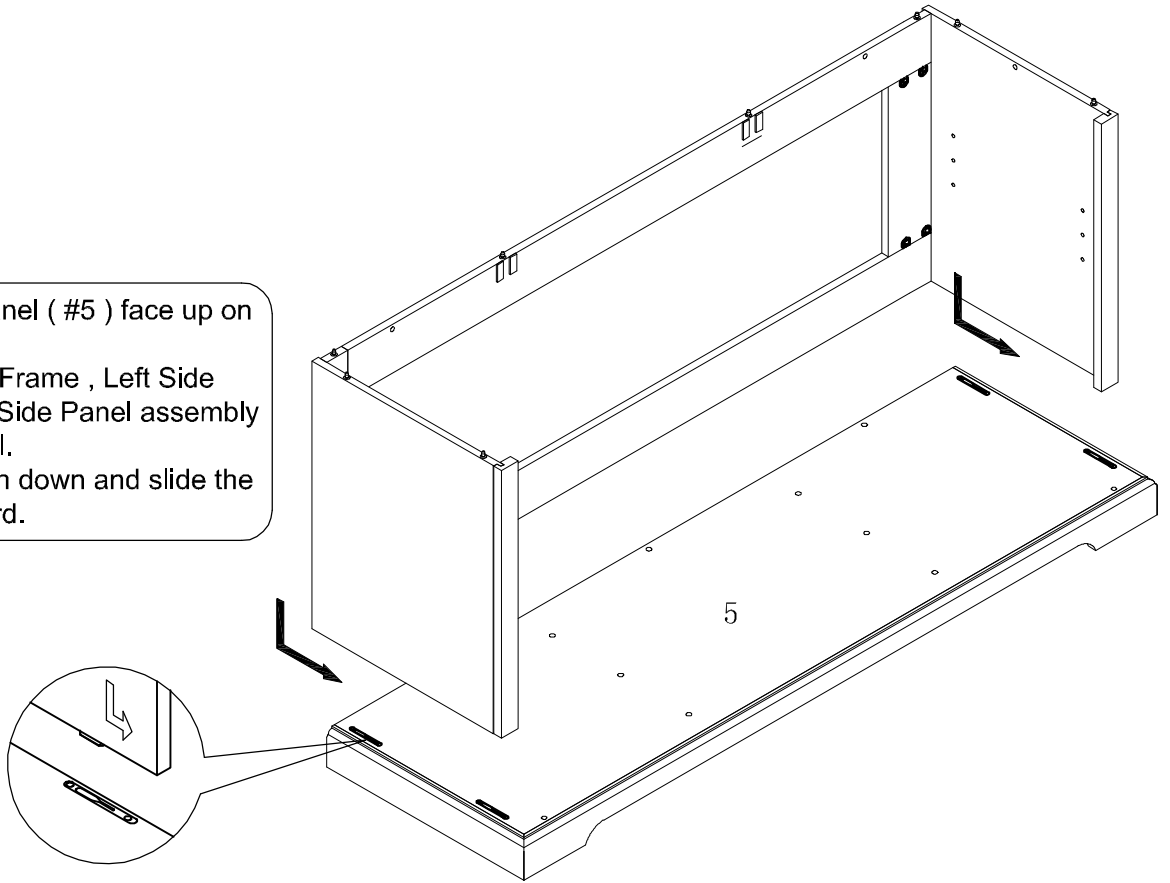

Step 4

Ⓐ —  — 4pcs

- Insert 4 Wooden Dowels (#A) into the Fixed Shelf (#4).
- Align the Fixed Shelf (#4), Left Divider (#6), & Right Divider (#7) as shown.
- NOTE the position of the Drawer Glides.

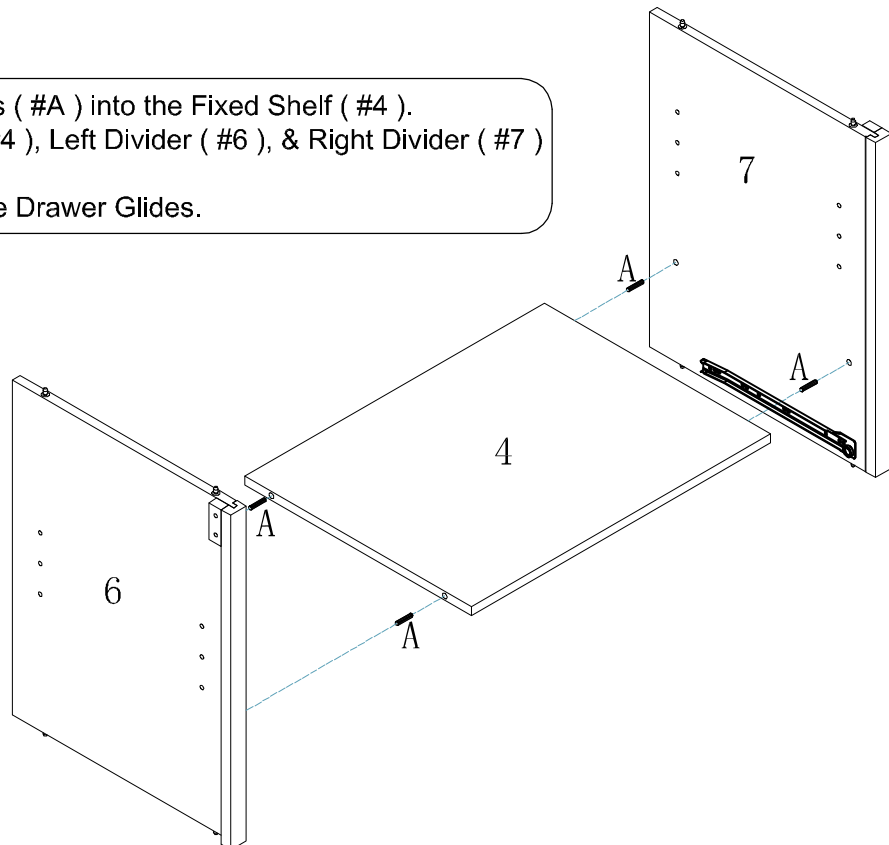

Step 5

- Carefully lift the Left Divider (#6), Right Divider (#7), and Fixed Shelf (#4) onto the Bottom Panel (#5) aligning the pins with the Bottom Panel (#5).

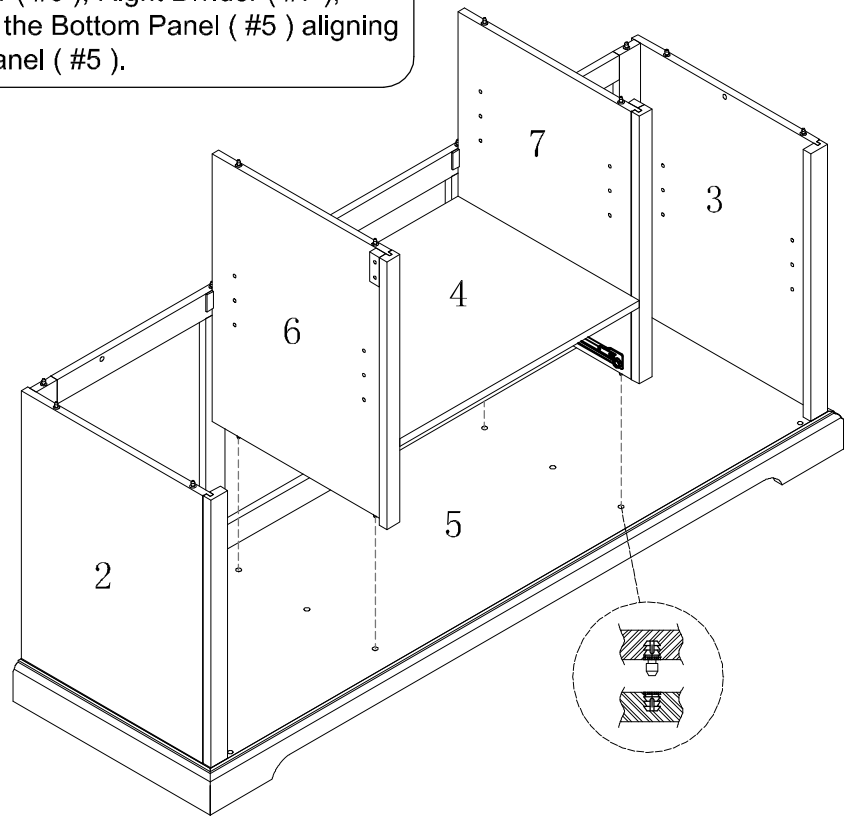

Step 6

(D) —  — 3pcs

- Tilt main assembly onto its back and thread the Legs (#9) through the Bottom Panel (#5) and into the Dividers.
- Thread the Adjustable Screws (D) into the Bottom Panel (#5) as shown.

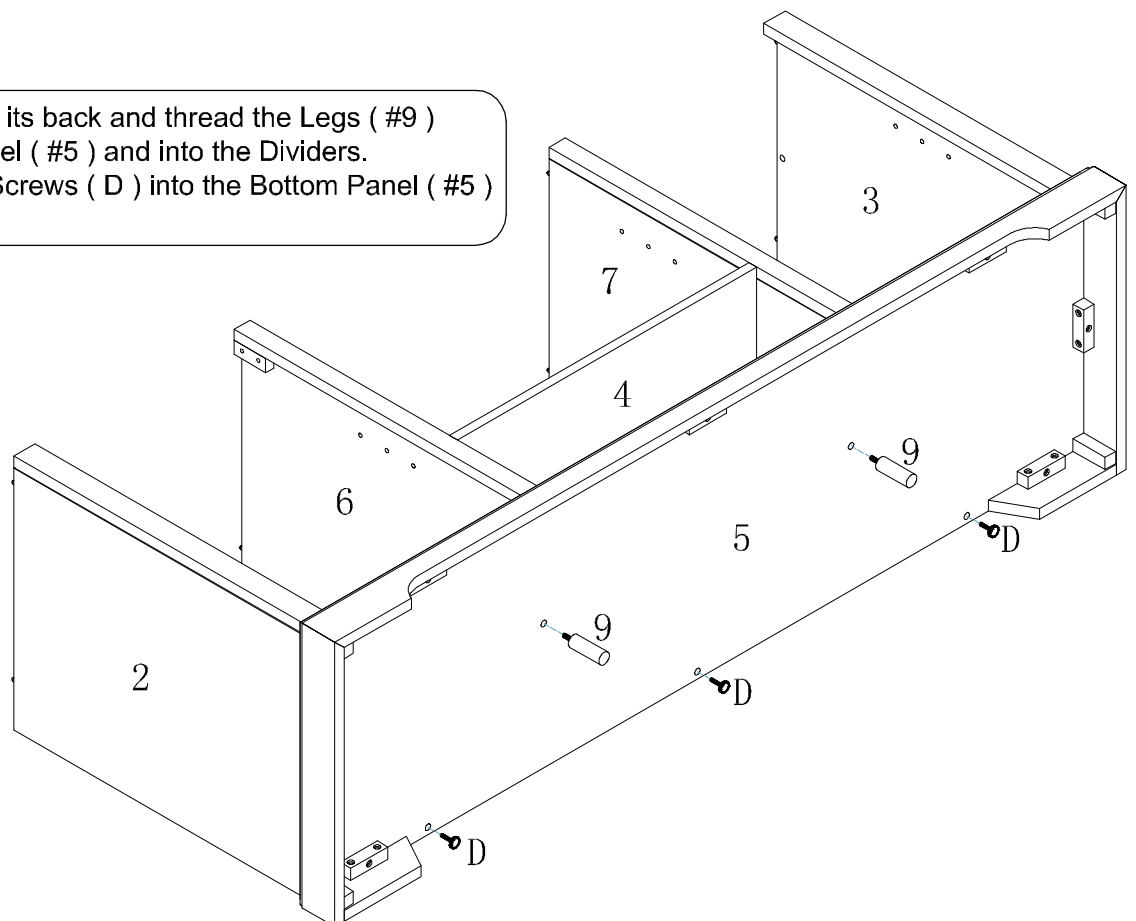

Step 7

(E) —  — 4pcs

- Insert the Half-Moon Slides (E) into the slots on the back side of Top Panel (#8), then slide the part (E) to fasten it on the slot as indicated.

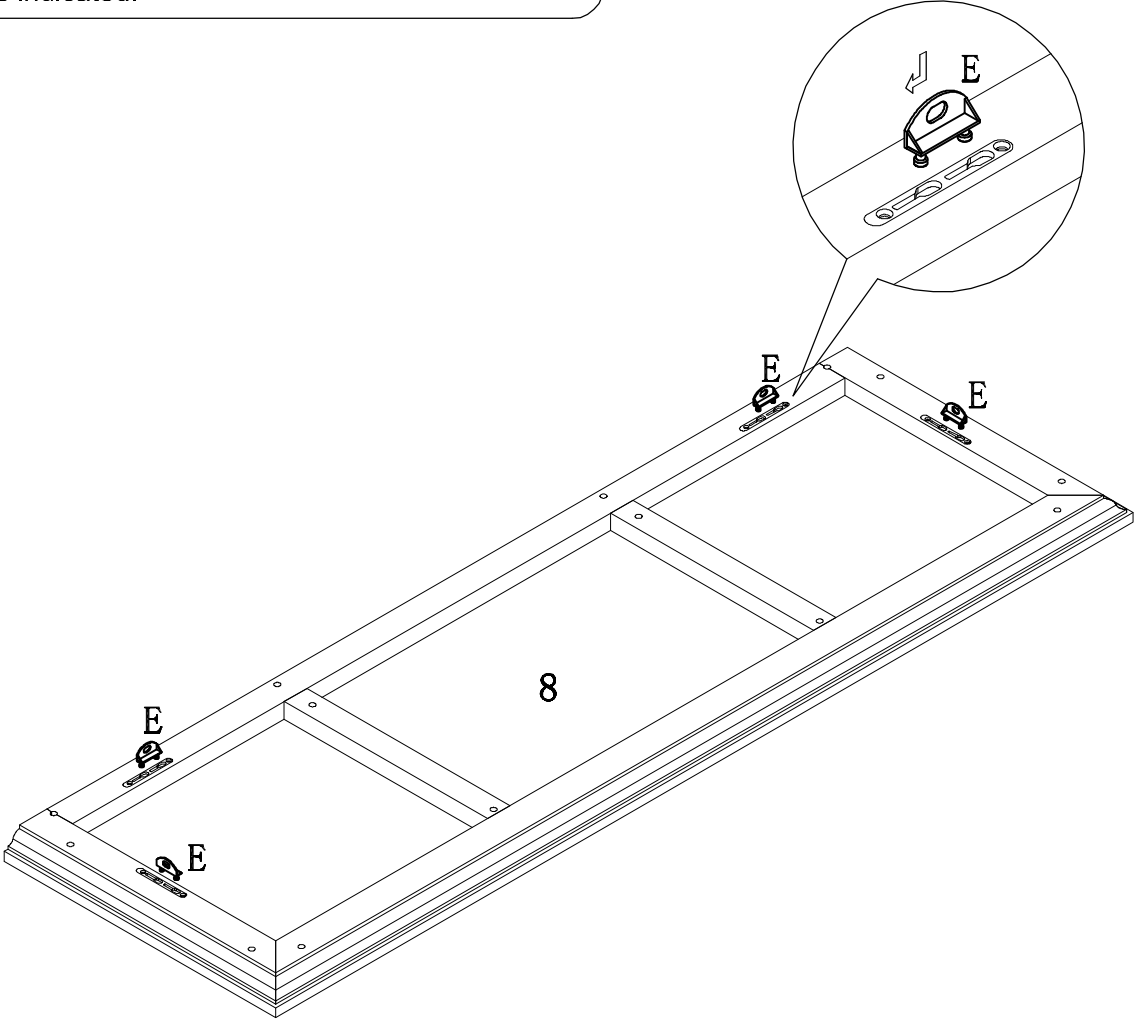

Step 8

(F) —  — 4pcs

(C) —  — 2pcs

- Align the Left Door (#10) and the Right Door (#11) with the side panels as shown.
- Align the Top Panel (#8) with the pins on the main unit.
- Insert the Plastic Insert Pins (F) as shown.
- Insert the Magnets (C) into the Divider Panels.

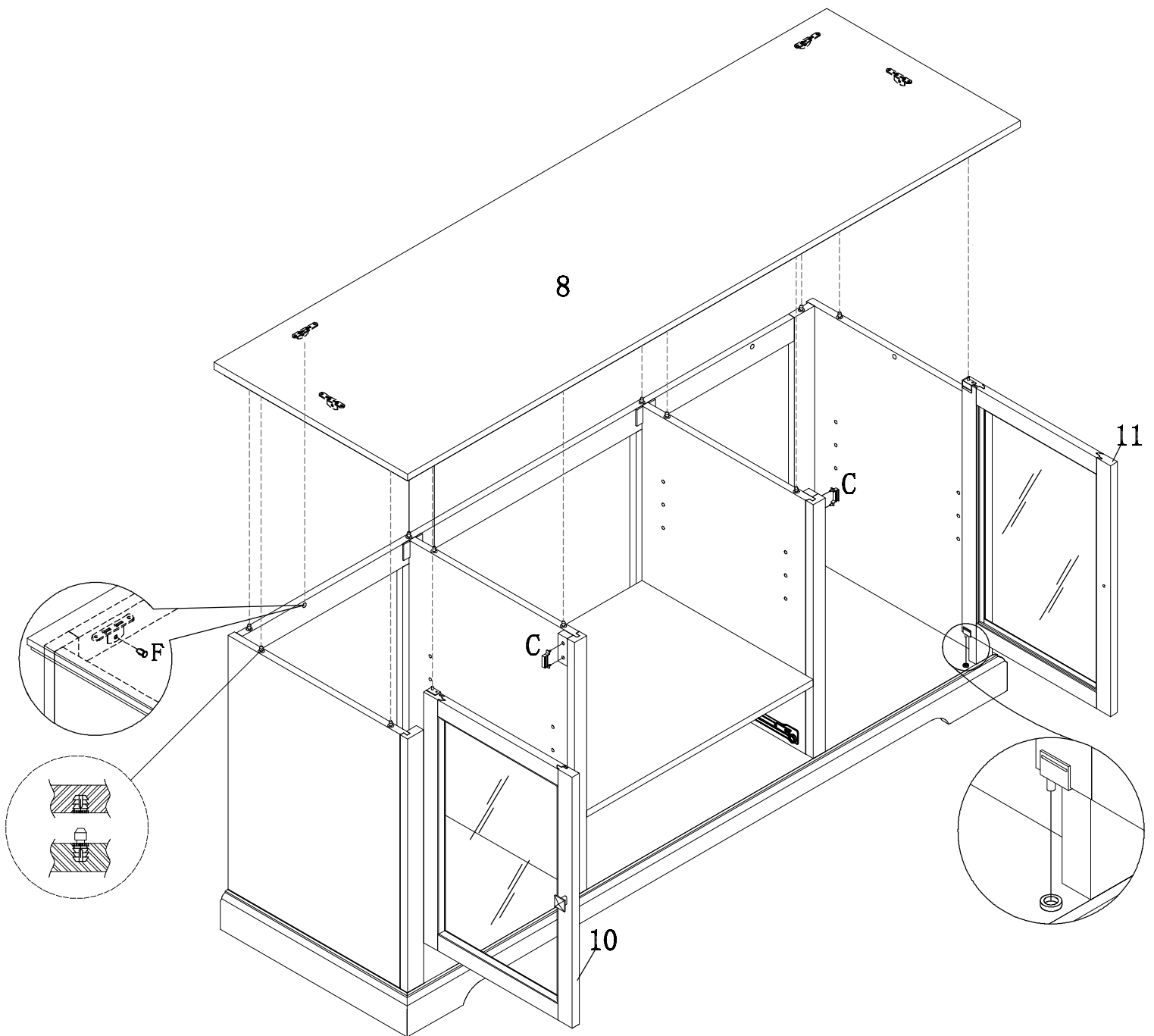

Step 9

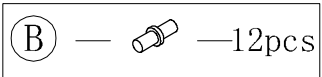

- Insert Shelf Pins (B) into Side Panels and Dividers at the desired height.
- Slide Loose Shelves (#17 & #18) onto Shelf Pins.
- NOTE : It may be necessary to tilt the Loose Shelves to slide into place.

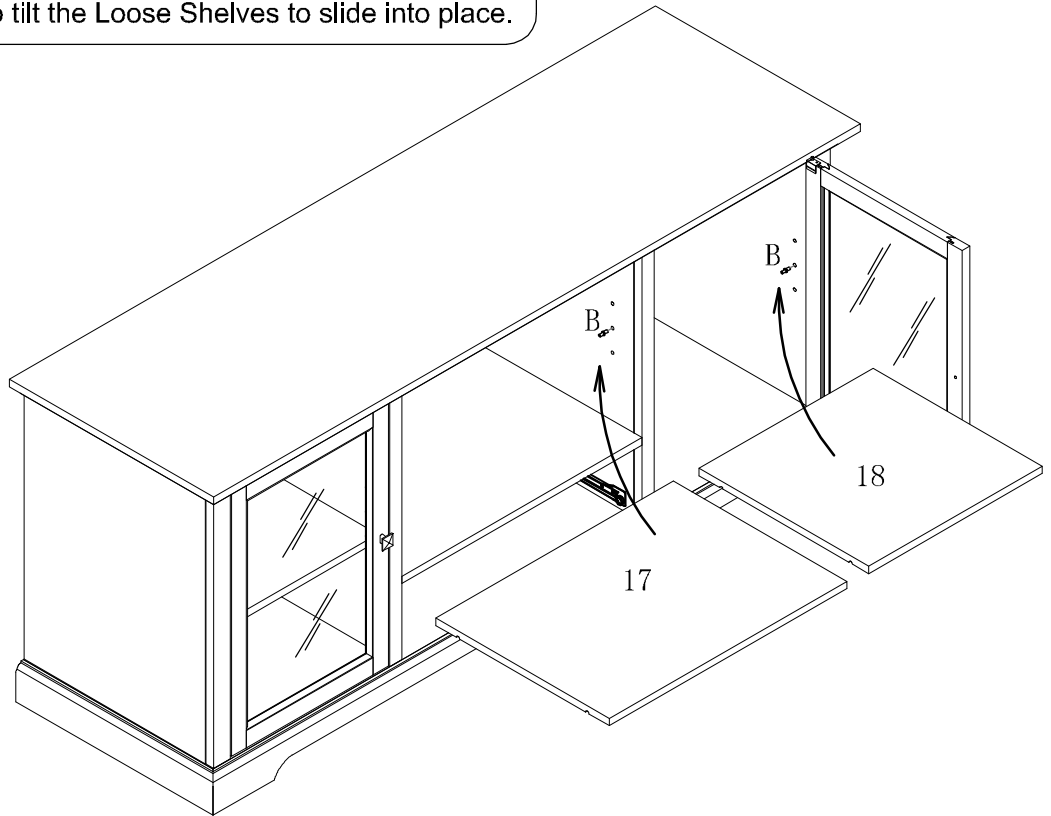

Step 10

- Left Drawer Side (#13), Drawer Back (#15), Right Drawer Side (#14) and the Drawer Bottom (#16) and align as shown.
- Turn the fitting switch to lock parts into place. (See Illustration.)

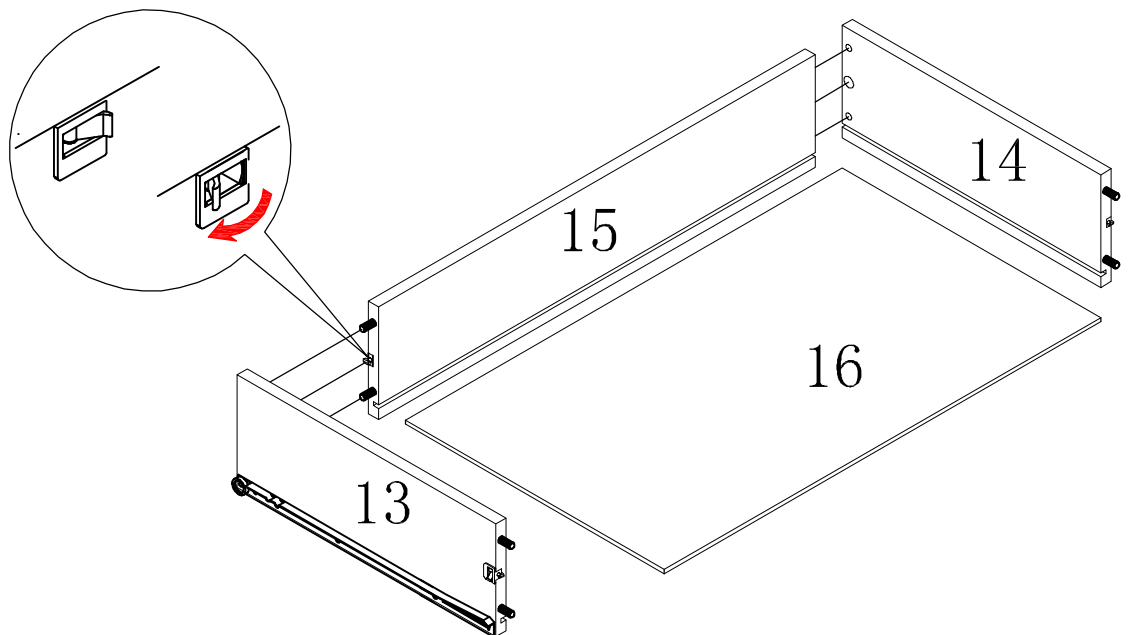

Step 11

- Select the Drawer Front (#12) and align as shown.
- Turn the fitting switch to lock parts into place.
(See Illustration.)

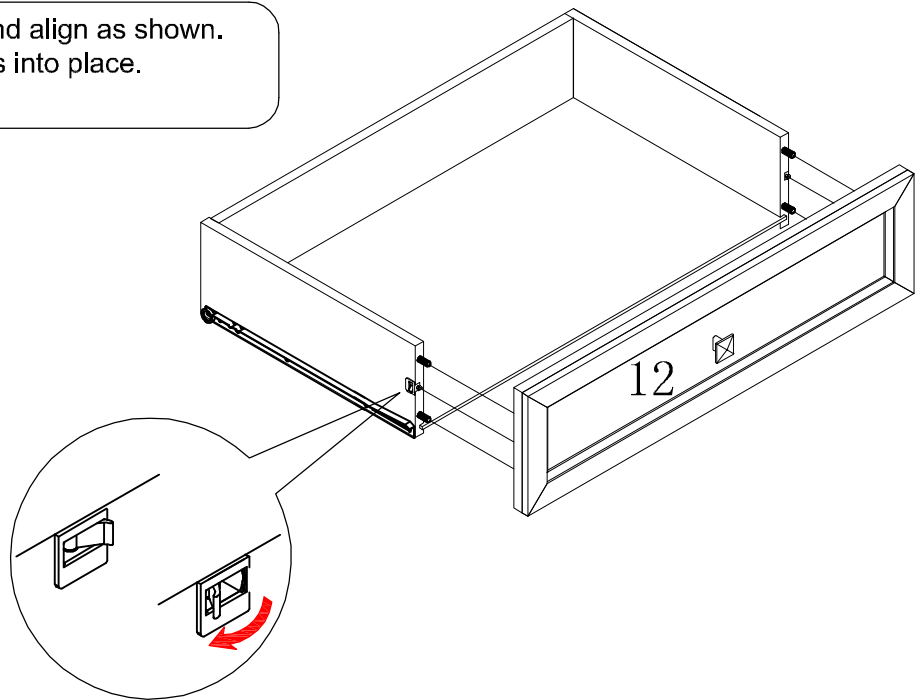

Step 12

- Align the Drawer assembly with the Dividers and the slide Drawer into place.

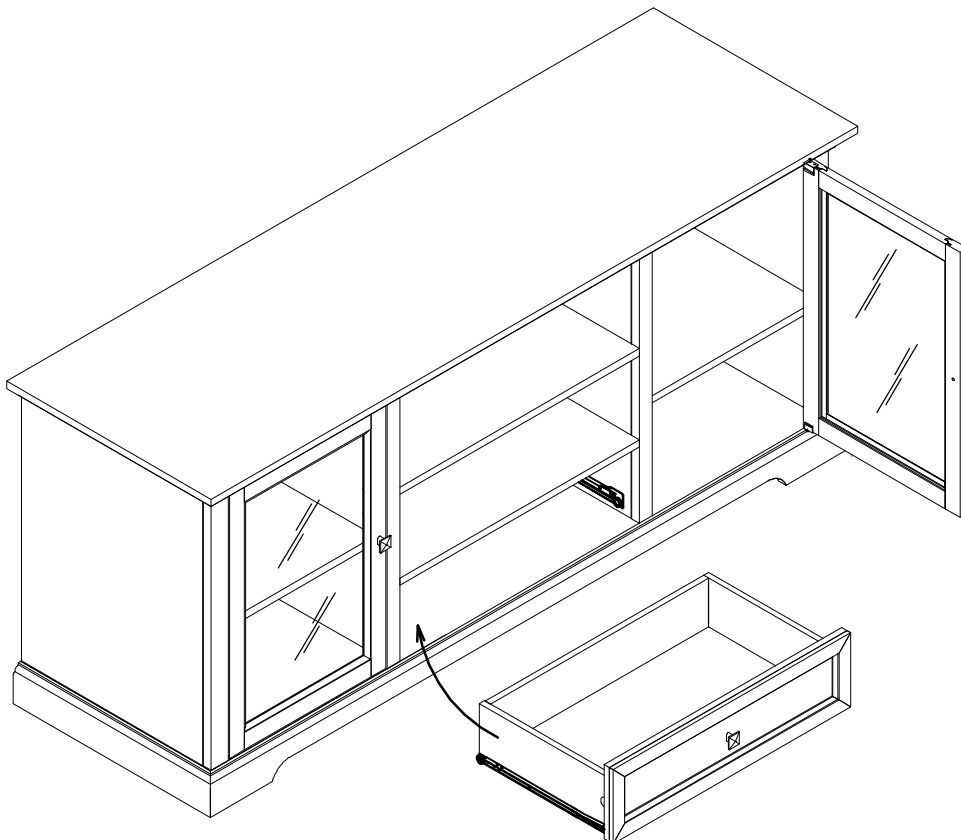

Step 13

- Move unit close to its final position.
- Load electronic equipment in the cabinet.
- Thread cords through the back.
- Attach the Magnetic Backing (#19 & 20).
- Move unit to its final position.

