

**INSTALLER: THESE INSTRUCTIONS MUST BE CONVEYED TO AND REMAIN WITH THE HOMEOWNER.**

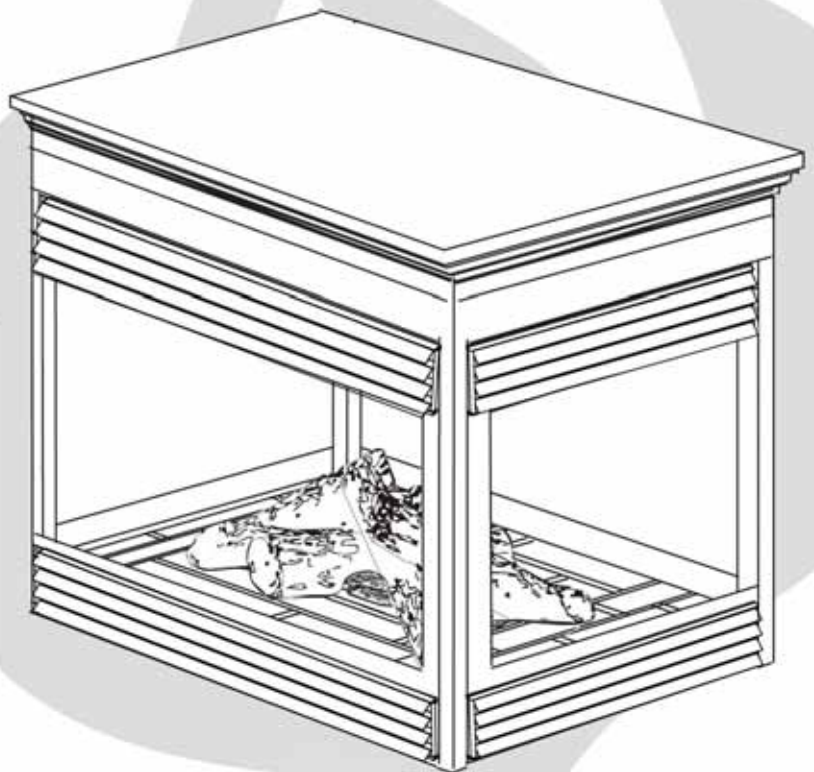


# INSTALLATION AND OPERATION INSTRUCTIONS

CERTIFIED UNDER AMERICAN NATIONAL STANDARDS, ANSI Z21.11.2b, VOLUME II FOR UNVENTED ROOM HEATERS.

**GVF40P**  
PROPANE

**GVF40N**  
NATURAL GAS



CERTIFIED FOR CANADA AND UNITED STATES USING ANSI/CSA METHODS.

## SAFETY INFORMATION

**WARNING:** If the information in these instructions are not followed exactly, a fire or explosion may result causing property damage, personal injury or loss of life.

- Do not store or use gasoline or other flammable vapors and liquids in the vicinity of this or any other appliance.
- **WHAT TO DO IF YOU SMELL GAS:**
  - Do not try to light any appliance
  - Do not touch any electrical switch; do not use any phone in your building.
  - Immediately call your gas supplier from a neighbour's phone. Follow the gas supplier's instructions.
  - If you cannot reach your gas supplier, call the fire department.
- Installation and service must be performed by a qualified installer, service agency or the supplier.



APPLY SERIAL NUMBER LABEL FROM CARTON



Serial No. XXXXXX000000  
MODEL NO.

**Wolf Steel Ltd., 103 Miller Drive, Crittenden, Kentucky, USA, 41030 / 24 Napoleon Rd., Barrie, ON, L4M 4Y8, Canada  
(705)721-1212 · fax(705)722-6031 · www.napoleonfireplaces.com · ask@napoleon.on.ca**

# TABLE of CONTENTS

## PG 3-4 INTRODUCTION

Warranty  
 General Instructions  
 General Information  
 Care of Glass Doors, Catalytic Tiles  
 & Plated Parts

## 5-12 INSTALLATION

Combustion and Ventilation Air Provisions  
 Determining Confined or Unconfined Space  
 Gas Installation  
 Framing Dimensions  
 Peninsula Installation Procedure  
 Open End Installation Procedure  
 See-Thru Installation Procedure  
 Island Installation Procedure

## 13-15 FINISHING

Log Placement  
 Glowing Embers  
 Charcoal Embers  
 Mantle Installation  
 Curtain Mesh  
 Hood  
 Louvre Bracket  
 Hinge Screen  
 Louvre Installation & Removal

Heat Shield Stand Off Removal  
 Logo Placement

## 16-17 OPTIONS

Patented Catalytic Glass Door  
 Blower Installation

## 18-19 OPERATION / MAINTENANCE

Operating Instructions  
 Maintenance  
 Catalytic Tile Maintenance  
 Oxygen Depletion Sensor Pilot Cleaning  
 Pilot Flame Appearance  
 Venturi Adjustment

## 20-21 REPLACEMENTS

Ordering Replacement Parts  
 Replacement Parts

## 22-23 TROUBLE SHOOTING GUIDE

### WARNING

### 24 NOTES

## PLEASE RETAIN THIS MANUAL FOR FUTURE REFERENCE

- Under no circumstances should this heater be modified.
- Provide adequate ventilation and combustion air. Provide adequate accessibility clearance for servicing and operating the heater. Never obstruct the front opening of the heater.
- If heater shuts off, do not re-light until you provide fresh air. If heater keeps shutting off, have it serviced. Keep burner and control compartment clean.
- Do not burn wood or other materials in this heater.
- Adults and especially children should be alerted to the hazards of high surface temperatures and should stay away to avoid burns or clothing ignition. Keep young children and animals away when the fireplace is hot.
- Due to high temperatures, the heater should be located out of traffic and away from furniture and draperies.
- Clothing or other flammable material should not be placed on or near the heater.
- Any safety screen or guard removed for servicing must be replaced prior to operating the heater.
- It is imperative that the control compartments, burners and circulating air passageways in the heater are kept clean. The heater should be inspected before use and at least annually by a qualified service person. More frequent cleaning may be required due to excessive lint from carpeting, bedding material, etc. The heater area must be kept clear and free from combustible materials, gasoline and other flammable vapours and liquids.
- Furniture or other objects must be kept a minimum of 4 feet away from the front of the fireplace.
- Do not use this heater if any part has been under water. Immediately call a qualified service technician to inspect the heater and to replace any part of the control system and any gas control which has been under water.
- Do not allow fans to blow directly into the fireplace. Avoid any drafts that alter burner flame patterns.
- Do not use a blower insert, heat exchanger insert or other accessory not approved for use with this heater.

***ANY CHANGE TO THIS HEATER OR ITS CONTROLS CAN BE DANGEROUS AND IS PROHIBITED.***

*NAPOLEON® gas fireplaces are manufactured under the strict Standard of the world recognized  
ISO 9001 : 2000 Quality Assurance Certificate.*

*NAPOLEON® products are designed with superior components and materials, assembled by trained craftsmen who take great pride in their work. The burner and valve assembly are leak and test-fired at a quality test station. The complete fireplace is test-fired and thoroughly inspected by a qualified technician before packaging to ensure that you, the customer, receives the quality product that you expect from NAPOLEON®.*

#### NAPOLEON® GAS FIREPLACE PRESIDENT'S LIFETIME LIMITED WARRANTY

***The following materials and workmanship in your new NAPOLEON® gas fireplace are warranted against defects for as long as you own the fireplace. This covers: combustion chamber, heat exchanger, stainless steel burner, phazer™ logs and embers, ceramic glass (thermal breakage only), gold plated parts against tarnishing, porcelainized enamelled components and aluminum extrusion trims.***

***Electrical (110V and millivolt) components and wearable parts such as catalytic tiles, blowers, gas valves, thermal switch, switches, wiring, remote controls, ignitor, gasketing, and pilot assembly are covered and NAPOLEON® will provide replacement parts free of charge during the first year of the limited warranty.***

***Labour related to warranty repair is covered free of charge during the first year. Repair work, however, requires the prior approval of an authorized company official. Labour costs to the account of NAPOLEON® are based on a predetermined rate schedule and any repair work must be done through an authorized NAPOLEON® dealer.***

#### CONDITIONS AND LIMITATIONS

NAPOLEON® warrants its products against manufacturing defects to the original purchaser only -- i.e., the individual or legal entity (registered customer) whose name appears on the warranty registration card filed with NAPOLEON® -- provided that the purchase was made through an authorized NAPOLEON® dealer and is subject to the following conditions and limitations:

This factory warranty is nontransferable and may not be extended whatsoever by any of our representatives.

The gas fireplace must be installed by a licenced, authorized service technician or contractor. Installation must be done in accordance with the installation instructions included with the product and all local and national building and fire codes.

This limited warranty does not cover damages caused by misuse, lack of maintenance, accident, alterations, abuse or neglect and parts installed from other manufacturers will nullify this warranty.

This limited warranty further does not cover any scratches, dents, corrosion or discolouring caused by excessive heat, abrasive and chemical cleaners nor chipping on porcelain enamel parts, mechanical breakage of PHAZER™ logs and embers, nor any venting components used in the installation of the fireplace.

NAPOLEON® warrants its stainless steel burners against defects in workmanship and material for life, subject to the following conditions: During the first 10 years NAPOLEON® will replace or repair the defective parts at our option free of charge. From 10 years to life, NAPOLEON® will provide replacement burners at 50% of the current retail price.

In the first year only, this warranty extends to the repair or replacement of warranted parts which are defective in material or workmanship provided that the product has been operated in accordance with the operation instructions and under normal conditions.

After the first year, with respect to this President's Limited Lifetime Warranty, NAPOLEON® may, at its discretion, fully discharge all obligations with respect to this warranty by refunding to the original warranted purchaser the wholesale price of any warranted but defective part(s).

After the first year, NAPOLEON® will not be responsible for installation, labour or any other costs or expenses related to the reinstallation of a warranted part, and such expenses are not covered by this warranty.

Notwithstanding any provisions contained in this President's Limited Lifetime Warranty, NAPOLEON'S responsibility under this warranty is defined as above and it shall not in any event extend to any incidental, consequential or indirect damages.

This warranty defines the obligations and liability of NAPOLEON® with respect to the NAPOLEON® gas fireplace and any other warranties expressed or implied with respect to this product, its components or accessories are excluded.

NAPOLEON® neither assumes, nor authorizes any third party to assume, on its behalf, any other liabilities with respect to the sale of this product. NAPOLEON® will not be responsible for: over-firing, downdrafts, spillage caused by environmental conditions such as rooftops, buildings, nearby trees, hills, mountains, inadequate vents or ventilation, excessive venting configurations, insufficient makeup air, or negative air pressures which may or may not be caused by mechanical systems such as exhaust fans, furnaces, clothes dryers, etc.

Any damages to fireplace, combustion chamber, heat exchanger, brass trim or other component due to water, weather damage, long periods of dampness, condensation, damaging chemicals or cleaners will not be the responsibility of NAPOLEON®.

The bill of sale or copy will be required together with a serial number and a model number when making any warranty claims from your authorized dealer. The warranty registration card must be returned within fourteen days to register the warranty.

NAPOLEON® reserves the right to have its representative inspect any product or part thereof prior to honouring any warranty claim.

## GENERAL INSTRUCTIONS

*THIS GAS FIREPLACE SHOULD BE INSTALLED AND SERVICED BY A QUALIFIED INSTALLER* to conform with local codes. Installation practices vary from region to region and it is important to know the specifics that apply to your area, for example: in Massachusetts State:

- The appliance off valve must be a "T" handle gas cock.
- The flexible connector must not be longer than 36 inches.
- The appliance is not approved for installation in a bedroom or bathroom unless the unit is a direct vent sealed combustion product.
- A carbon monoxide detector is required in all rooms containing gas fired appliances.
- **WARNING:** This product must be installed by a licensed plumber or gas fitter when installed within the commonwealth of Massachusetts.
- Un-vented room heater shall be installed in accordance with 527 CMR 30.00 and 248 CMR 3.00 through 7.00.
- Sellers of un-vented propane or natural gas-fired space/room heaters shall provide to each purchaser a copy of 527 CMR 30.00 upon the sale of the unit from [http://www.napoleonfireplaces.com/Webshare/installation\\_manuals/mass\\_requirements.pdf](http://www.napoleonfireplaces.com/Webshare/installation_manuals/mass_requirements.pdf)

In absence of local codes, install the **GVF40** to the current National Fuel Gas Code, ANSI Z223.1 Installation Code which can be obtained from:

**American Nation Standards Institute Inc.**

1430 Broadway  
New York, NY 10018  
or

**National Fire Protection Association Inc.**

Batterymarch Park  
Quincy, MA 02269

The fireplace and its individual shutoff valve must be disconnected from the gas supply piping system during any pressure testing of that system at test pressures in excess of 1/2 psig (3.5 kPa). The fireplace must be isolated from the gas supply piping system by closing its individual manual shutoff valve during any pressure testing of the gas supply piping system at test pressures equal to or less than 1/2 psig (3.5 kPa).

When the fireplace is installed directly on carpeting, vinyl tile or other combustible material other than wood flooring, the fireplace shall be installed on a metal or wood panel extending the full width and depth.

If the optional fan or blower is installed, the junction box must be electrically connected and grounded in accordance with local codes. In the absence of local codes, use the current ANSI/NFPA 70 NATIONAL ELECTRICAL CODE in the United States.

## GENERAL INFORMATION

*FOR YOUR SATISFACTION, THIS FIREPLACE HAS BEEN TEST-FIRED TO ASSURE ITS OPERATION AND QUALITY!* Maximum input is 30,000 BTU/hr for natural gas and 28,500 BTU/hr for propane. When the fireplace is installed at elevations above 2,000ft, and in the absence of specific recommendations from the local authority having jurisdiction, the certified high altitude input rating shall be reduced at the rate of 4% for each additional 1,000ft.

***This heater must not be installed in a bedroom or bathroom.***

***This fireplace may be installed in an aftermarket permanently located, manufactured (mobile) home, where not prohibited by local codes.***

***This fireplace is only for use with the type of gas indicated on the rating plate. This fireplace is not convertible for use with other gases, unless a certified kit is used.***

Minimum inlet gas supply pressure is 4.5 inches water column for natural gas and 11 inches water column for propane. Maximum inlet gas pressure is 7 inches water column for natural gas and 13 inches water column for propane. Manifold pressure under flow conditions is 3.5 inches water column for natural gas and 10 inches water column for propane.

***No external electricity (110 volts or 24 volts) is required for the gas system operation.***

Expansion / contraction noises during heating up and cooling down cycles are normal and are to be expected.

## CARE OF OPTIONAL GLASS DOORS, CATALYTIC TILES AND PLATED PARTS

Do not use abrasive cleaners to clean plated parts. Buff lightly with a clean dry cloth. This fireplace may have optional glass doors which are equipped with either 3/16" thick tempered or ceramic glass. Use only replacement glass available from your Napoleon® dealer. DO NOT SUBSTITUTE MATERIALS. Clean the glass after the first 10 hours of operation with a recommended gas fireplace glass cleaner. Thereafter clean as required. DO NOT CLEAN GLASS WHEN HOT! If the glass is not kept clean permanent discoloration and / or blemishes may result. Catalytic tiles normally do not require cleaning. Physical contact should be avoided. See *Maintenance*.

**This heater is equipped with a pilot light safety system referred to as an *OXYGEN DEPLETION SENSOR* and is designed to turn off the heater if not enough fresh air is available.**

**Use only accessories designed for and listed with your specific fireplace.**

## CARBON MONOXIDE POISONING MAY LEAD TO DEATH

Early signs of carbon monoxide poisoning resemble the flu, with headache, dizziness and/or nausea. If you have these signs, the heater may not be working properly. **Get fresh air at once! Have heater serviced.**

Some people---pregnant women, persons with heart or lung disease, anaemia, those under the influence of alcohol, those at high altitudes--- are more affected by carbon monoxide than others.

# INSTALLATION

## COMBUSTION AND VENTILATION AIR PROVISIONS

*This heater shall not be installed in a confined space or unusually tight construction unless provisions are provided for adequate combustion and ventilation air.*

***In order to avoid the possibility of exposed insulation or vapour barrier coming in contact with the fireplace body, it is recommended that the walls of the fireplace enclosure be 'finished', (i.e. drywall/sheetrock) as would any other outside wall of the home. This will ensure that clearance to combustibles is maintained within the cavity.***

The *National Fuel Gas Code, ANSI Z223.1* defines a confined space as a space whose volume is **less than 50 cubic feet** per 1,000 Btu per hour (4.8 m<sup>3</sup> per kW) of the aggregate input rating of all appliances installed in that space and an unconfined space as a space whose volume is **not less than 50 cubic feet** per 1,000 BTU per hour (4.8 m<sup>3</sup> per kW) of the aggregate input rating of all appliances installed in that space. Rooms communicating directly with the space in which the appliances are installed, through openings not furnished with doors are considered a part of the unconfined space.

*The GVF40 is rated at 30,000BTUs per hour for natural gas and 28,500 BTUs for propane and therefore requires a minimum unconfined space of 1,500 and 1,425 cubic feet respectively.*

## DETERMINING CONFINED OR UNCONFINED SPACE

To determine the volume of the room where the heater is to be installed, multiply the width x the length x the ceiling height of that room measured in feet. If any adjoining rooms are connected by grills or openings such as kitchen pass-throughs, etc., the volume of those rooms may be added to the total.

Multiply the room volume by 1000 and divide this amount by 50 to determine the maximum Btu/hr that the space can support with adequate combustion and ventilation air.

Add the BTU/hr of all fuel burning appliances located within the space such as gas furnace, gas water heater, etc. Do not include direct vent gas appliances which draw their input and output air from and to the outdoors.

**WARNING:** If the area in which the heater may be operated is smaller than that defined as an unconfined space or if the building is of unusually tight construction, provide adequate combustion and ventilation air by one of the methods described in the *National Fuel Gas Code ANSI Z223.1, Section 5.3* or the applicable local code.

**Unusually tight construction is defined as construction where:**

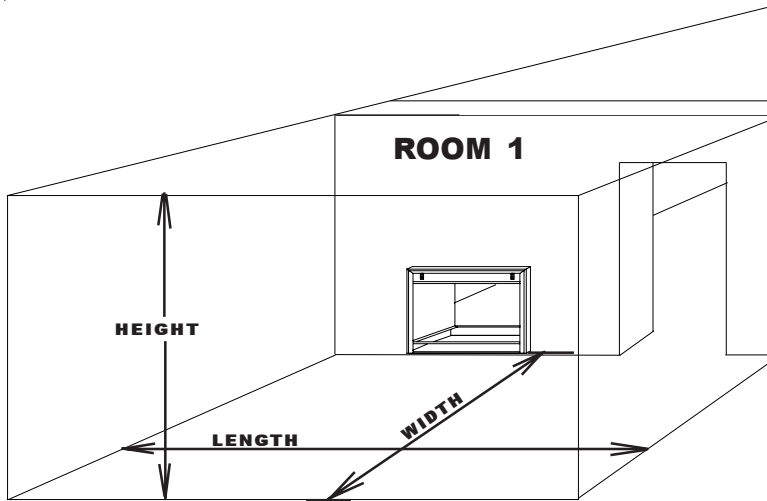
- a) Walls and ceilings exposed to the outside atmosphere have a continuous water vapour retarder with a rating of 1 perm (6 x 10<sup>-11</sup> kg per pa-sec-m<sup>2</sup>) or less with openings gasketed or sealed, and
- b) Weather stripping has been added on openable windows and doors, and
- c) Caulking or sealants are applied to areas such as joints around window and door frames, between sole plates and floors, between wall-ceiling joints, between wall panels, at penetrations for plumbing, electrical, and gas lines, and at other openings.

An unvented room heater is recommended for use as a secondary heat source rather than as a primary source. Gas combustion produces water vapour which could occur at the rate of approximately one ounce of water for every 1,000 BTU/hr of gas input. During the cold weather season, indoor humidity levels tend to be low. Consequently, this water vapour can enhance the living space. However if a problem should occur:

- a) ensure sufficient combustion and circulation air
- b) use a dehumidifier
- c) do not use the unvented room heater as a primary heat source

Without sufficient fresh air for proper operation, poor fuel combustion can result. Carbon Monoxide is a result of poor combustion.

**If additional fresh air is required,** use one of the methods described in the *National Fuel Gas Code, ANSI Z223.1, Section 5.3* or the applicable local code.



**Room Volume = Length x Width x Height**  
**Max BTU/hr = Room Volume x 1000 ÷ 50**

### EXAMPLE 1

In this example, because there is no door to the adjoining room, the volume of the adjoining room may be added to the volume of the room with the heater to get a total unconfined space.

The total unconfined space: 800 + 1200 = 2000 cubic feet.

Maximum BTU/h:  $\frac{2000 \times 1000}{50} = 40,000$  BTU/h

If there are no more fuel burning appliances within this space then the 30,000 BTU/h input of the fireplace is suitable to be installed. This also assumes that the construction of this space is not unusually tight.

### ROOM 2

### FIGURE 1

If for example, the length of the rooms is 10 feet, the width of Room 1 is 10 feet, the width of Room 2 is 15 feet the height of the rooms is 8 feet.

The volume of Room 1: 10 x 10 x 8 = 800 cubic feet.

The volume of Room 2: 10 x 15 x 8 = 1200 cubic feet.

### EXAMPLE 2

If in this example a solid door separates Room 1 from Room 2, the volume of Room 2 could not be used. In this case the maximum BTU/h would be:

Maximum BTU/h:  $\frac{800 \times 1000}{50} = 16,000$  BTU/h

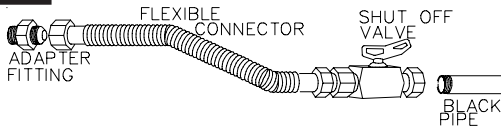
This would be considered a confined space since it can not support the 30,000BTU/h input of the heater and it would be necessary to provide adequate combustion and ventilation air to Room 1.

## GAS INSTALLATION

1. Move the fireplace into position and secure to the floor through the 1/4"Ø holes located at the four outside corners of the base.

2. Install rigid black pipe, 1/2" type-L copper tubing or, if local codes permit, a 3/8" flex connector and shutoff valve to the gas line and the fireplace gas valve. Seal and tighten securely. An adapter fitting is required between the gas valve and the copper tubing or flex connector.

### FIGURE 2 DO NOT KINK FLEX CONNECTOR.



3. Check for gas leaks by brushing on a soap and water solution.

### DO NOT USE OPEN FLAME.

4. For ease of accessibility, an optional remote wall switch or millivolt thermostat may be installed in a convenient location. Route a 2 strand, solid core millivolt wire through the electrical hole located at the bottom left side of the unit. The recommended maximum lead length depends on wire size:

### WIRE SIZE

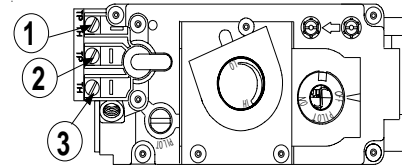
14gauge  
16gauge  
18gauge

### MAX. LENGTH

100 feet  
60 feet  
40 feet

5. Attach the two leads to terminals 1 and 3 located on the gas valve.

### FIGURE 3



**Do not connect either the wall switch, thermostat or gas valve to electricity (110 volts).**

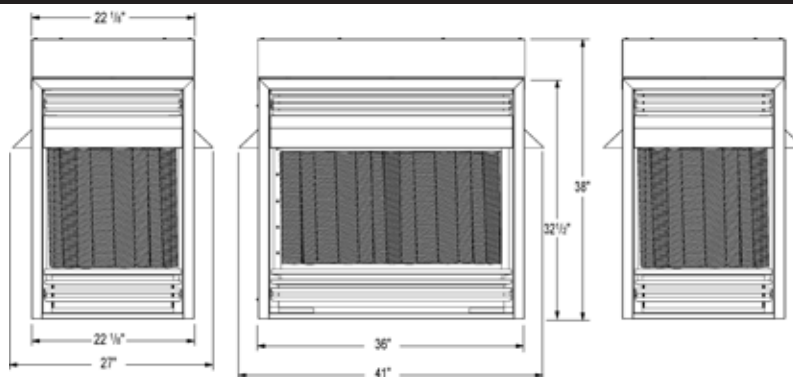
6. Mark the appropriate boxes on the rating plate label to indicate the model type.

### USING DOOR OPTION:

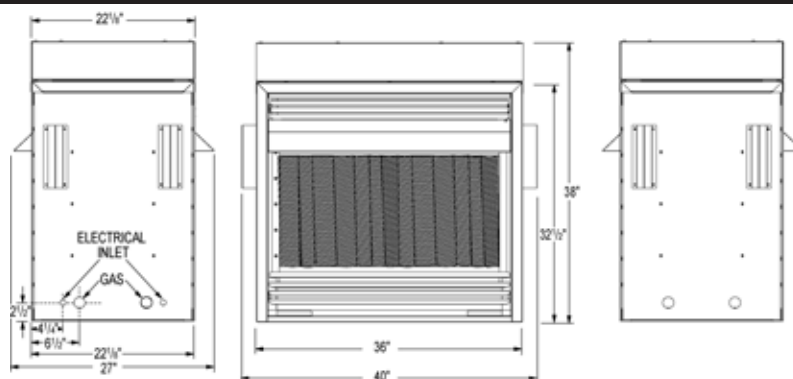
**Purge all gas lines with the glass door of the fireplace opened. Assure that a continuous gas flow is at the burner before closing the door.**

## 4-SIDED

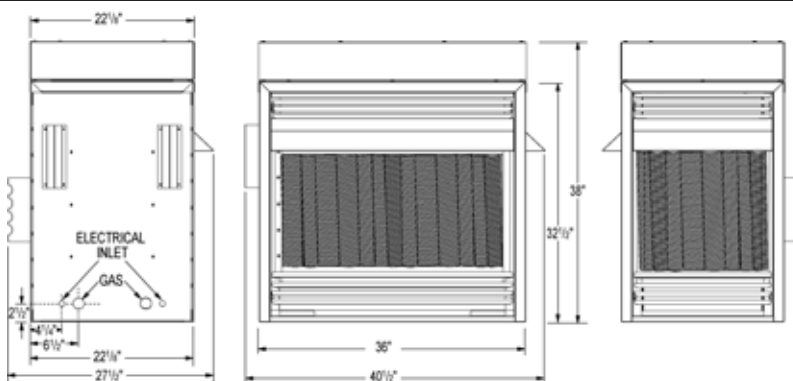
FIGURES 4 a-d



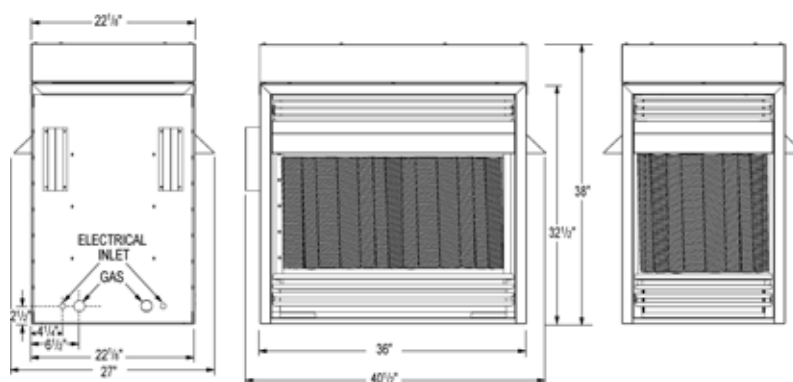
## SEE-THRU



## OPEN-END



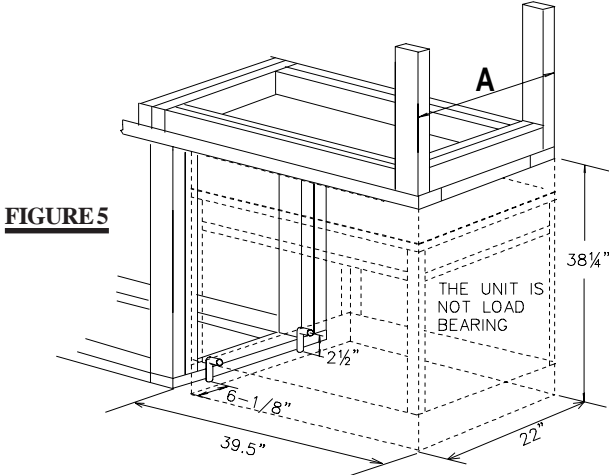
## PENINSULA



# PENINSULA INSTALLATION PROCEDURE

## FRAMING

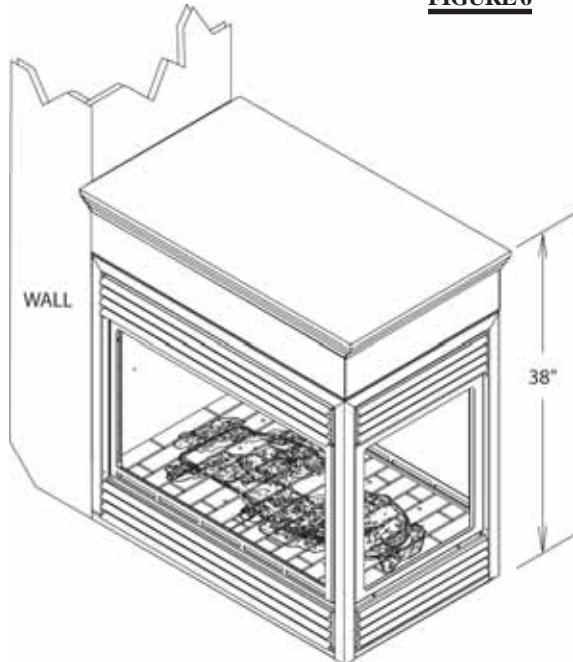
**Note:** In order to avoid the possibility of exposed insulation or vapour barrier coming in contact with the fireplace body, it is recommended that the walls of the fireplace enclosure be "finished" (ie: drywall/sheetrock), as you would finish any other outside wall of a home. This will ensure that clearance to combustibles is maintained within the cavity. It is best to frame your fireplace after it is positioned. Use 2x4's and frame to local building codes. **FIGURE 5.**



A = 22 " minus finishing material thickness each side.

To install the fireplace face flush with the finished wall, position the framework to accommodate the thickness of the finished wall.

**FIGURE 6**

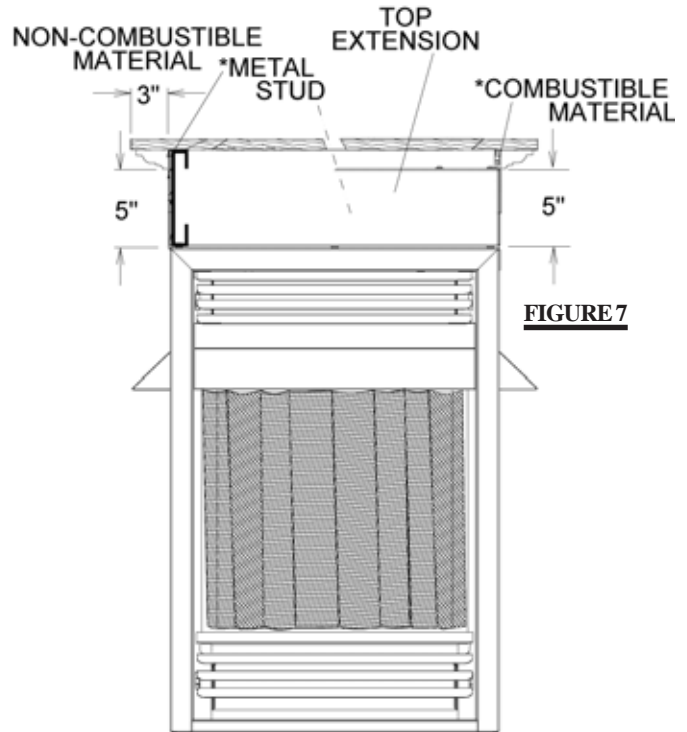


## COUNTERTOP / BAR INSTALLATION

When finishing the fireplace, combustible material may rest directly on of the top extension.

**Note:** Maximum weight tolerance is 400 lbs, provided that it is evenly distributed across the top extensions of the fireplace.

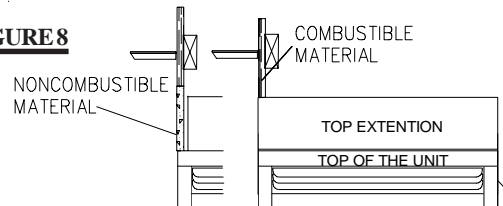
In order to achieve a countertop or bar type appearance with the minimum height allowed, framing must be non-combustible and may be done with metal studding attached to the heat shield sides or the upper frame of the fireplace. **FIGURE 7.**



**FIGURE 7**

\* The top extension may be removed if non-combustible framing is faced with a non-combustible material placed flush with the front face of the unit and extending from the top of the unit. (Example: cement board) (not supplied). Combustible counter / bar tops must maintain a minimum of 38 inches from the base of the fireplace to the underside of the top. **Figure 8.**

**FIGURE 8**

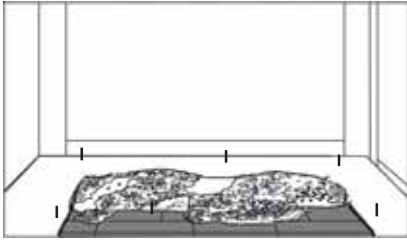


**NOTE:** Wolf Steel trim and/or surround kits will not totally cover the top extension of the fireplace. In order to obtain a smooth transition from the trim / surround to the wall, it is recommended that the top extension be removed and the unit be installed following the above procedure.



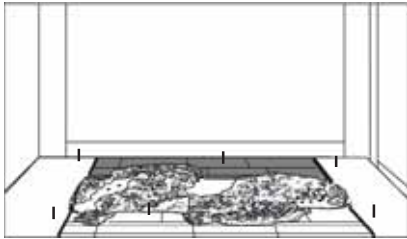
## BRICK PANEL INSTALLATION

Install the base panels as illustrated in steps 1-4 . The side panel sits under the bracket tab. Holding the side panel in position, bend down the tab to secure. **[DETAIL 5.]**

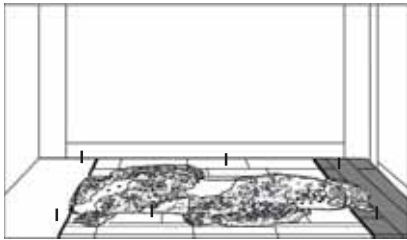


**FIGURES 9a-e**

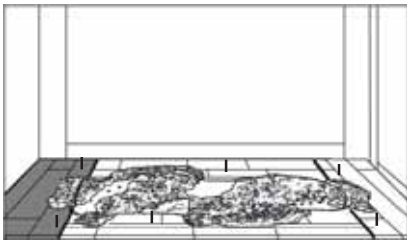
**STEP 1**



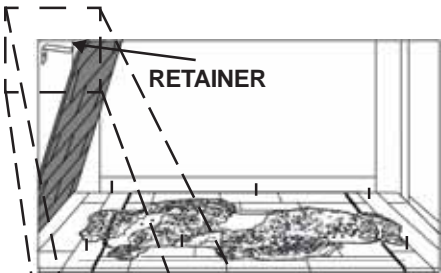
**STEP 2**



**STEP 3**



**STEP 4**



**STEP 5**

**DETAIL 5**

## FACING

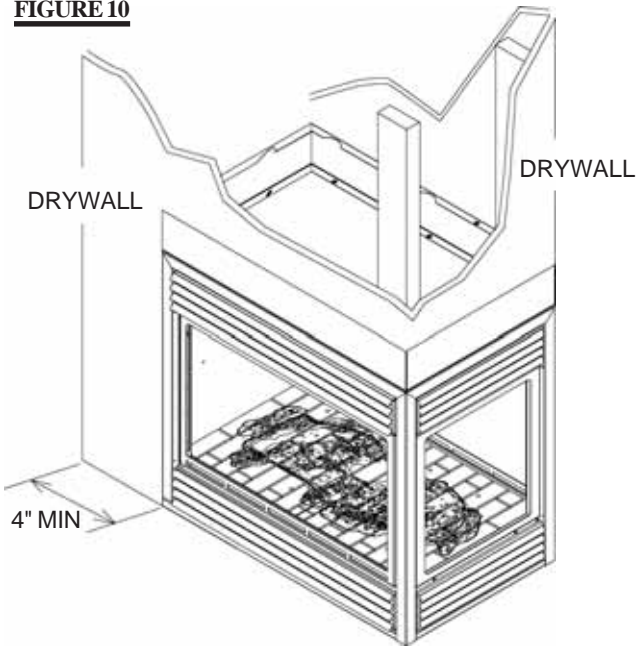
Combustible materials may be installed flush with the front of the fireplace but must not cover any of the black face-areas of the fireplace. Non-combustible material (brick, stone or ceramic tile) may protrude in these areas.

It is not necessary to install a hearth extension with this fireplace system.

When roughing in the fireplace, raise the fireplace to accommodate for the thickness of the finished floor materials, i.e. tile, carpeting, hard wood, which if not planned for will interfere with the opening of the lower access door and the installation of many decorative flashing accessories.

**Objects placed in front of the fireplace should be kept a minimum of 48" away from the glass front faces of the fireplace.**

**FIGURE 10**



## FINISHING

Refer to pages 13-15 for complete instructions regarding mantle requirements and installations, log placement, glass door and upper and lower louvre attachments.

# OPEN-END INSTALLATION PROCEDURE

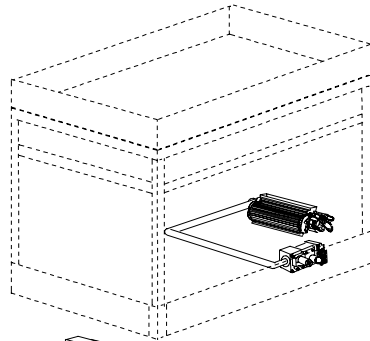
## FRAMING

**Note:** In order to avoid the possibility of exposed insulation or vapour barrier coming in contact with the fireplace body, it is recommended that the walls of the fireplace enclosure be “finished” (ie: drywall/sheetrock), as you would finish any other outside wall of a home. This will ensure that clearance to combustibles is maintained within the cavity.

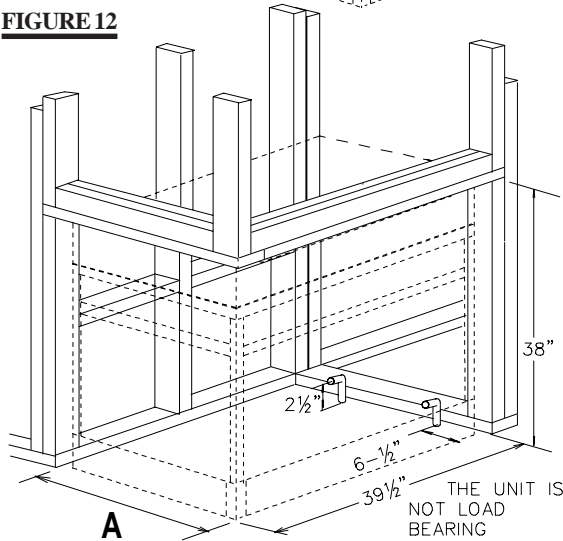
It is best to frame your fireplace after it is positioned and the vent system is installed. Use 2x4's and frame to local building codes. **FIGURE 11.**

See PAGE 8 for bar type / countertop installation.

**FIGURE 11**



**FIGURE 12**



$A = 25\frac{1}{4}''$  minus finishing material thickness each side.

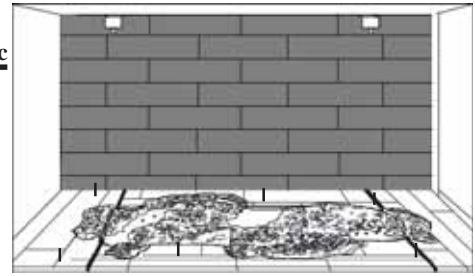
*NOTE: LEFT CORNER UNIT ILLUSTRATED*

To install the fireplace face flush with the finished wall, position the framework to accommodate the thickness of the finished wall.

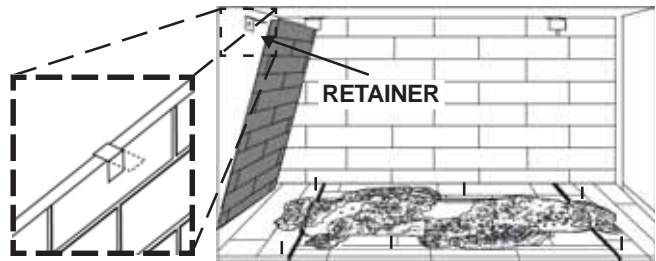
## BRICK PANEL INSTALLATION

Install the base panels as illustrated in steps 1-4 on page 9. The side panel sits under the bracket tab. Holding the side panel in position, bend down the tab to secure. [DETAIL 6].

**FIGURES 13 a-c**



**STEP 5**



**DETAIL 6**

**STEP 6**

## FACING

Combustible materials may be installed flush with the front of the fireplace but must not cover any of the black face-areas of the fireplace. Non-combustible material (brick, stone or ceramic tile) may protrude in these areas.

It is not necessary to install a hearth extension with this fireplace system.

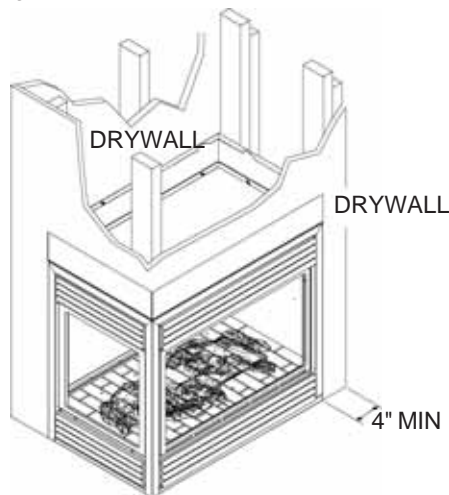
When roughing in the fireplace, raise the fireplace to accommodate for the thickness of the finished floor materials, i.e. tile, carpeting, hard wood, which if not planned for will interfere with the opening of the lower access door and the installation of many decorative flashing accessories.

**Objects placed in front of the fireplace should be kept a minimum of 48" away from the glass front faces of the fireplace.**

## FINISHING

Refer to pages 13-15 for complete instructions regarding mantle requirements and installations, log placement, glass door and upper and lower louvre attachments.

**FIGURE 14**



# SEE-THROUGH INSTALLATION PROCEDURE

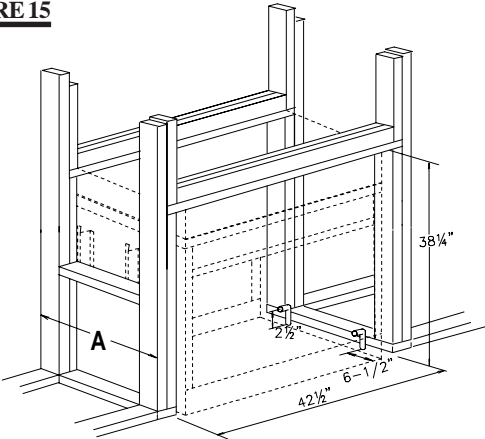
## FRAMING

**Note:** In order to avoid the possibility of exposed insulation or vapour barrier coming in contact with the fireplace body, it is recommended that the walls of the fireplace enclosure be “finished” (ie: drywall/sheetrock), as you would finish any other outside wall of a home. This will ensure that clearance to combustibles is maintained within the cavity.

It is best to frame your fireplace after it is positioned and the vent system is installed. Use 2x4's and frame to local building codes. **FIGURE 15.**

See PAGE 8 for bar type / countertop installation.

**FIGURE 15**

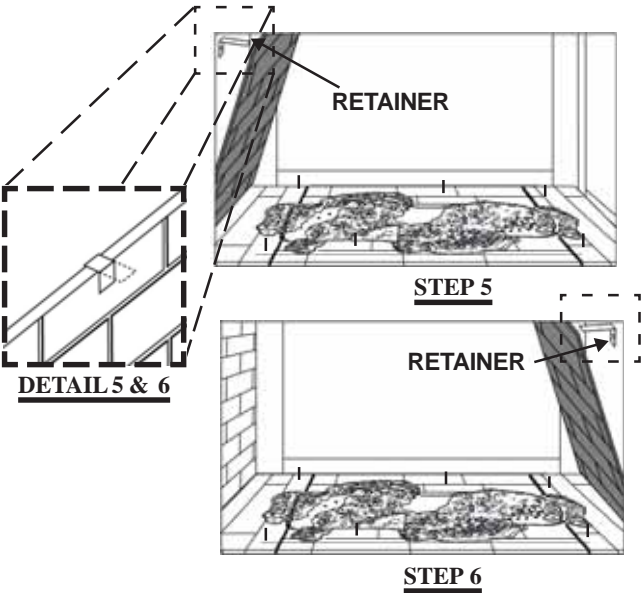


A = 22" minus finishing material thickness, each side.

## BRICK PANEL INSTALLATION

Install the base panels as illustrated in steps 1-4 on page 9. Both side panels sit under the bracket tab. Holding the side panel in position, bend down the tab to secure. [**DETAIL 6**].

**FIGURES 16 a-c**



## FACING

Combustible materials may be installed flush with the front of the fireplace but must not cover any of the black face-areas of the fireplace. Non-combustible material (brick, stone or ceramic tile) may protrude in these areas.

It is not necessary to install a hearth extension with this fireplace system.

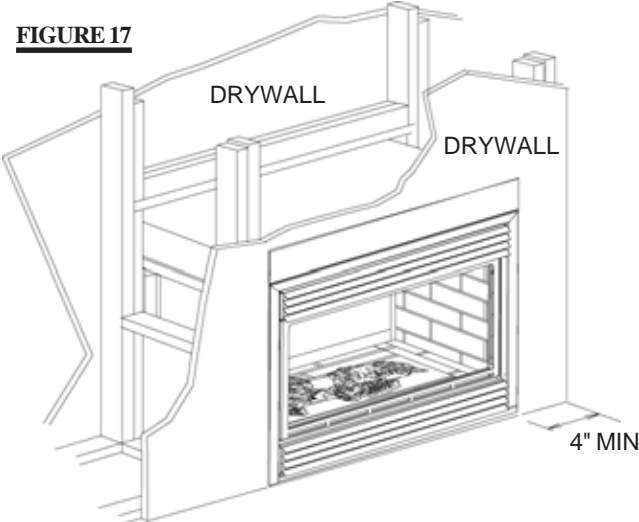
When roughing in the fireplace, raise the fireplace to accommodate for the thickness of the finished floor materials, i.e. tile, carpeting, hard wood, which if not planned for will interfere with the opening of the lower access door and the installation of many decorative flashing accessories.

**Objects placed in front of the fireplace should be kept a minimum of 48" away from the glass front faces of the fireplace.**

## FINISHING

Refer to pages 13-15 for complete instructions regarding mantle requirements and installations, log placement, glass door and upper and lower louvre attachments.

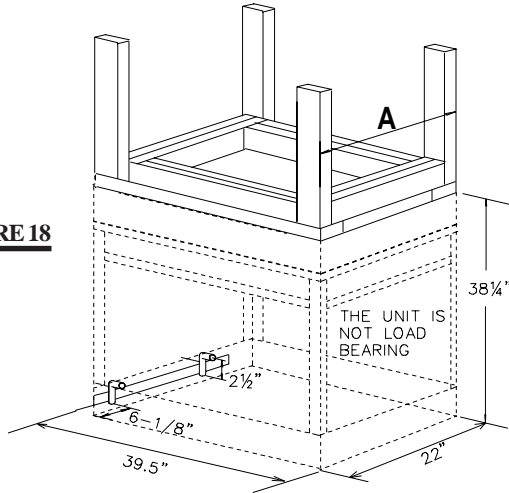
**FIGURE 17**



# ISLAND INSTALLATION PROCEDURE

## FRAMING

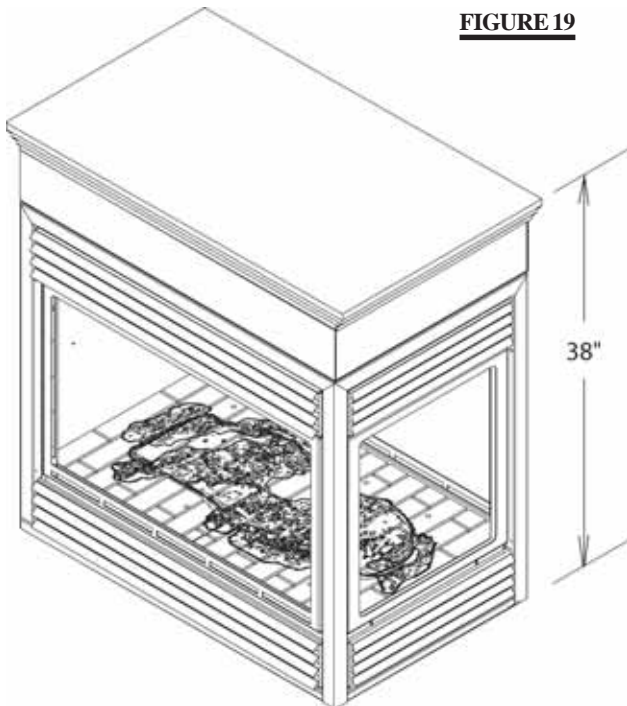
**Note:** In order to avoid the possibility of exposed insulation or vapour barrier coming in contact with the fireplace body, it is recommended that the walls of the fireplace enclosure be "finished" (ie: drywall/sheetrock), as you would finish any other outside wall of a home. This will ensure that clearance to combustibles is maintained within the cavity. It is best to frame your fireplace after it is positioned. Use 2x4's and frame to local building codes. **FIGURE 18.**



**FIGURE 18**

A = 22 " minus finishing material thickness each side.

To install the fireplace face flush with the finished wall, position the framework to accommodate the thickness of the finished wall.



**FIGURE 19**

## BRICK PANEL INSTALLATION

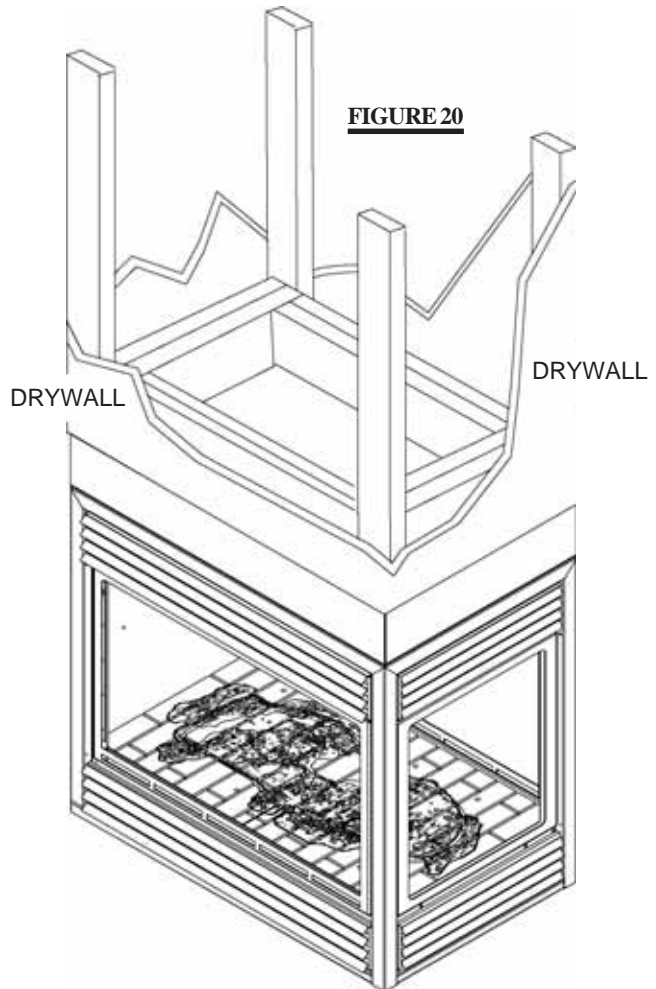
Install the base panels as illustrated in steps 1-4 on page 9.

## FACING

Combustible materials may be installed flush with the front of the fireplace but must not cover any of the black face-areas of the fireplace. Non-combustible material (brick, stone or ceramic tile) may protrude in these areas. It is not necessary to install a hearth extension with this fireplace system.

When roughing in the fireplace, raise the fireplace to accommodate for the thickness of the finished floor materials, i.e. tile, carpeting, hard wood, which if not planned for will interfere with the opening of the lower access door and the installation of many decorative flashing accessories.

**Objects placed in front of the fireplace should be kept a minimum of 48" away from the glass front faces of the fireplace.**



**FIGURE 20**

## FINISHING

Refer to pages 13-15 for complete instructions regarding mantle requirements and installations, log placement, glass door and upper and lower louvre attachments.

# FINISHING

## LOG PLACEMENT

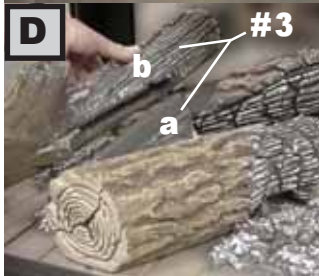
**PHAZER™** logs, glowing and charcoal embers, exclusive to Napoleon® fireplaces, provide a unique and realistic glowing effect that is different in every installation. Take the time to carefully position the embers for a maximum glowing effect. **Figures 21 A - H.**



**1.** Place log #1 diagonally across the textured burner cover onto the pins. The texture is designed to cradle the underside of the log.



**2.** Depending on the type of installation, the view of the log positioning will reverse. Here the lower end of log #2 rests near the *back left* corner of the firebox on the locating pin. The upper end sits on top of log #1, inside the groove on log #2.



**3.** Log #3 is made up of two pieces, a and b. Piece #3a is the base of log #3. The base sits diagonally in the designated area located between logs #1 and #2 and fits tight up against #2.

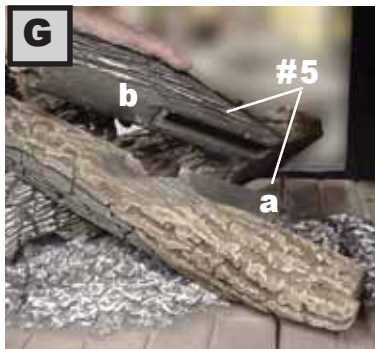
**4.** The slot in the underside of piece #3b fits over #3a. Place the end of piece #3b onto the pin.



**5.** When pieces #3a and #3b are attached to create log #3, the upper end of log #3 should rest in the groove, on top of log #2.



**6.** As with log #1, log #4 is also cradled by the texture of the burner cover and the pin in the base. Position log #4 so that the lower end fits onto the pin. The upper end rests against the moulded locator on the top of log #1.



**7.** Like log #3, log #5 also comes in two pieces. The base (#5a) slopes outwards between logs #2 and #4. As with pieces #3a & b, piece #5b fits over piece #5a. Place the end of piece #5b onto the pin.



**8.** The upper end of log #5 rests in the groove, on top of log #4 and creates the final appearance of the log set.

**GLOWING EMBERS**

Tear the embers into small pieces and place on the ported area of the burner. Care should be taken to shred the embers into thin, small irregular pieces as only the exposed edges of the fibre hairs will glow. *The ember material will only glow when exposed to direct flame; however, care should be taken to not block the burner ports.* Blocked burner ports can cause an incorrect flame pattern, carbon deposits and delayed ignition. **PHAZER™** logs glow when exposed to direct flame.

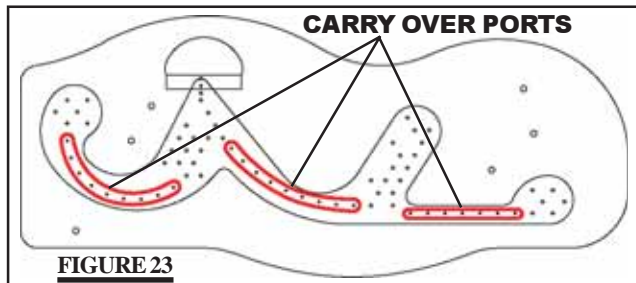
**CHARCOAL EMBERS**

Randomly place the embers around the bottom brick panels in a realistic manner but not in contact with the flames. Keep ember dust away from burner ports to avoid plugging them.

**Fine dust found in bottom of bag not to be used.** **PHAZER™** logs, and embers glow when exposed to direct flame. Use only certified **PHAZER™** logs, glowing embers and charcoal embers available from your Napoleon® / Wolf Steel Ltd. dealer.



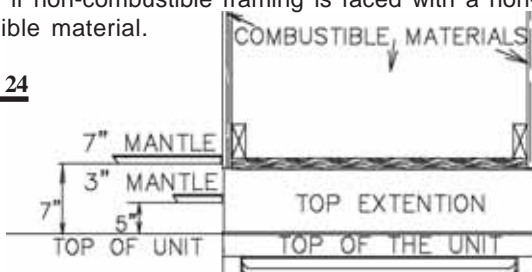
Ensure that glowing embers sufficiently cover the carry over ports, highlighted below, to achieve maximum glow.



**MANTLE INSTALLATION**

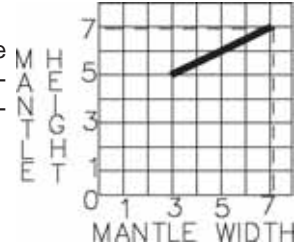
Combustible mantle clearance can vary according to the mantle depth. Use the graph to help evaluate the clearance needed. The four-sided top extension piece may be removed if non-combustible framing is faced with a non-combustible material.

**FIGURE 24**

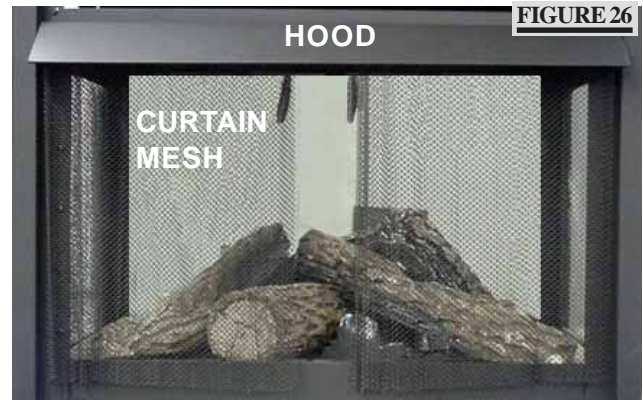


Dashed lines are suitable mantle sizes and clearances when a non-combustible facing is used.

**FIGURE 25**



**HOOD**



The curtain mesh must be kept fully closed during operation to help prevent accidental burns from occurring.



*The heater must not be used when the hood is removed.* Hook the hood over the lip of the curtain support plate.

**UPPER LOUVRE BRACKETS & HOOD**

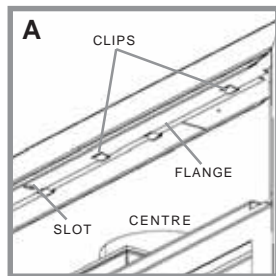
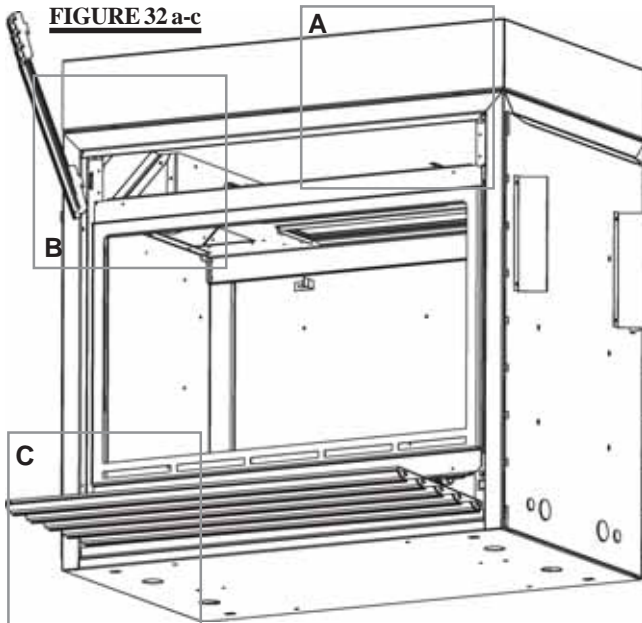
**FIGURE 28**



Attach the hood with louvre brackets by pressing the top flange of the bracket into the clips along the top of the louvre opening with louvre securing tabs facing out.

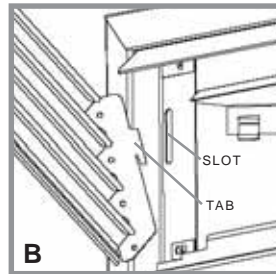
**NOTE:** The protective wrap is best removed when the assembly is at room temperature but this can be improved if the assembly is warmed, using a hair dryer or similar heat source.

**L36 LOUVRE INSTALLATION**



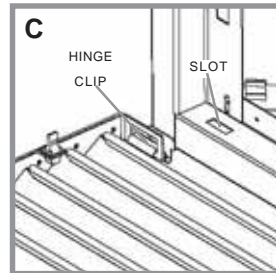
**HOOD**

Attach the hood by pressing the top flange into the clips along the top of the louvre opening. Secure using a screw through the centre slot.



**UPPER LOUVRES**

Insert the louvre tabs into the slots located at the top left and right corners of the unit.

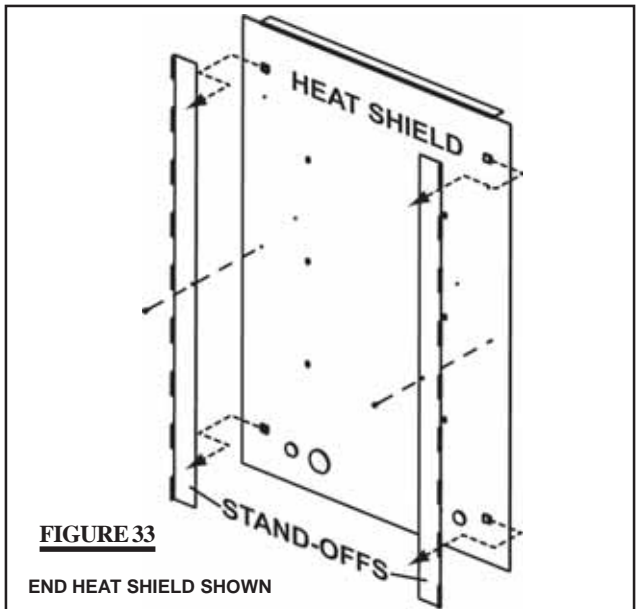


**LOWER LOUVRES**

Insert the hinge clips into the slots located at the bottom left and right corners of the unit.

To remove the louvres, pull the back tabs of the clips forward, while pushing the louvre assembly back. Lift the clip.

**HEAT SHIELD STAND-OFF REMOVAL**



When using a non-combustible finishing material, the stand-offs may be removed, by removing the set screw in the centre and sliding the stand-offs out of the mounting clips.

**LOGO PLACEMENT**

Remove the backing of the logo supplied and place on the screen cover, as indicated.



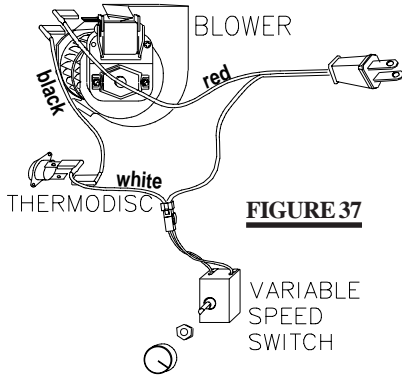
**FIGURE 34**

# OPTIONAL BLOWER INSTALLATION

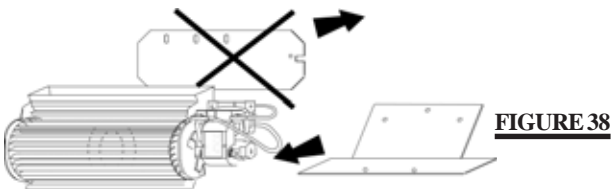
**THIS BLOWER IS NOT RECOMMENDED FOR THE 4 SIDED INSTALLATION.**

INSTALLATION TO BE DONE BY A QUALIFIED INSTALLER and must be electrically connected and grounded in accordance with local codes. In the absence of local codes, use the current ANSI/NFPA 70 NATIONAL ELECTRICAL CODE in the United States.

Remove the blower from its mounting bracket and attach to the bracket supplied with the fireplace. This bracket is found secured on the mounting stud located at the bottom of the vent side wall.

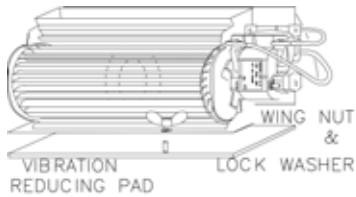


**FIGURE 37**



**FIGURE 38**

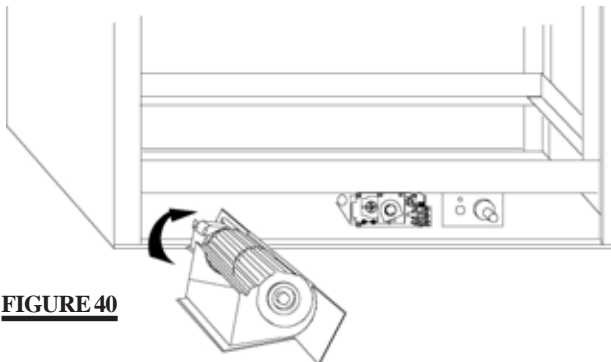
**FIGURE 39**



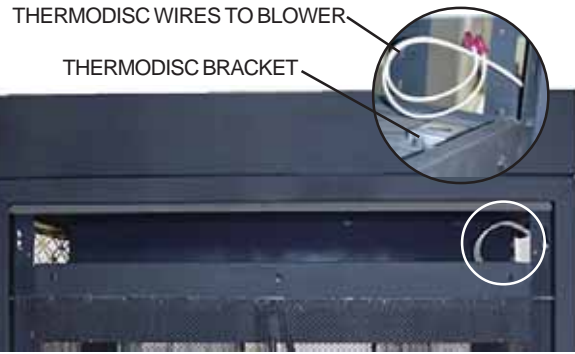
The blower bracket contains two holes that allow the blower to be positioned away from the intended gas supply hole.

Position the vibration reducing pad, centred, onto the threaded stud, piercing a hole into the pad. The blower must be able to be positioned entirely onto the pad.

Tilt the blower onto its side and slide it past the controls. Position the blower under the clip and onto the stud. Secure with a wing nut.



**FIGURE 40**



**FIGURE 41**

Remove the thermodisc bracket from the top of the firebox.

Remove the thermodisc from the bracket supplied in the blower kit and install the thermodisc into the fireplace bracket. Then replace the bracket in the location it was removed.

Connect the two ends of the unattached wires by the bracket to the thermodisc.

Connect the opposite ends of the wires to the red and black leads of the blower harness.

*The wire harness provided in this kit is a universal harness. When installed, ensure that any excess wire is contained, preventing it from making contact with moving or hot objects.*

*Drywall dust will penetrate into the blower bearings, causing irreparable damage. Care must be taken to prevent drywall dust from coming into contact with the blower or its compartment. Any damage resulting from this condition is not covered by the warranty policy.*

*Because the blower is thermally activated, when turned on, it will automatically start approximately 10 minutes after lighting the fireplace and will run for approximately 30 - 45 minutes after the fireplace has been turned off. Use of the fan increases the output of heat.*



## OPERATION / MAINTENANCE

*If heater shuts off, do not relight until you provide fresh air. If heater keeps shutting off, have it serviced. Keep burner and control compartment clean.*

When lit for the first time, the fireplace will emit a slight odour for a few hours. This is a normal temporary condition caused by the curing of the logs and the "burn-in" of internal paints and lubricants used in the manufacturing process and will not occur again.

After extended periods of non-operation such as following a vacation or a warm weather season, the fireplace may emit a slight odour for a few hours. This is caused by dust particles burning off. In both cases, open a window to sufficiently ventilate the room.

*Purge the gas line with the glass door open. Assure that a continuous gas flow is at the burner before closing the door.*

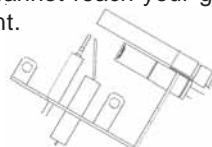
### FOR YOUR SAFETY READ BEFORE LIGHTING:

**WARNING: IF YOU DO NOT FOLLOW THESE INSTRUCTIONS EXACTLY, A FIRE OR EXPLOSION MAY RESULT CAUSING PROPERTY DAMAGE, PERSONAL INJURY OR LOSS OF LIFE.**

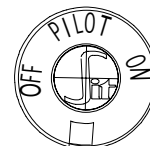
- A. This fireplace is equipped with a pilot which must be lit by hand while following these instructions exactly.
- B. Before operating smell all around the fireplace area for gas and next to the floor because some gas is heavier than air and will settle on the floor.
- C. Use only your hand to push in and turn the gas control knob. Never use tools. If the knob will not push in and turn by hand, do not try to repair it. Call a qualified service technician. Force or attempted repair may result in a fire or explosion.
- D. Do not use this fireplace if any part has been under water. Immediately call a qualified service technician to inspect the fireplace and replace any part of the control system and any gas control which has been under water.

### WHAT TO DO IF YOU SMELL GAS:

- Do not try to light any appliance.
- Do not touch any electric switch; do not use any phone in your building.
- Immediately call your gas supplier from a neighbour's phone. Follow the gas supplier's instructions.
- If you cannot reach your gas supplier, call the fire department.





OXYGEN DEPLETION SENSOR




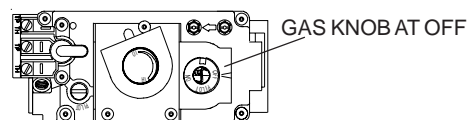
GAS KNOB

### LIGHTING INSTRUCTIONS

When lighting and re-lighting, the gas knob cannot be turned from pilot to off unless the knob is depressed.

1. STOP! Read the above safety information on this label.
2. Set the thermostat to lowest setting.
3. Turn off all electric power to the fireplace.
4. Open the control door. Turn the gas knob clockwise  to off.
5. Wait five (5) minutes to clear out any gas. If you smell gas including near the floor, STOP! Follow "B" in the above safety information on this label. If you don't smell gas go to the next step.
6. Find pilot located in front of the back log.
7. Turn gas knob counter-clockwise  to pilot.

8. Depress and hold gas knob while lighting the pilot with the push button igniter. Keep knob fully depressed for one minute, then release. If pilot does not continue to burn repeat steps 3 through 7.
9. With pilot lit, turn gas knob counter-clockwise  to on. When the pilot has been turned off, ignition of the main burner may be delayed from 1-2 minutes. When the pilot has been left burning, ignition of the main burner should occur almost immediately.
10. If equipped with remote on-off switch, main burner may not come on when you turn the valve to on. Remote switch must be in the on position to ignite burner.
11. Turn on all electric power to the fireplace.



### TO TURN OFF GAS

1. Turn off all electric power to the fireplace if service is to be performed.
2. Push in gas control knob slightly and turn clockwise  to off. Do not force.

## MAINTENANCE

### TURN OFF THE GAS AND ELECTRICAL POWER BEFORE SERVICING THE FIREPLACE.

**CAUTION:** Label all wires prior to disconnection when servicing controls. Wiring errors can cause improper and dangerous operation. Verify proper operation after servicing. This heater should be inspected and serviced before use and at least annually by a qualified service person. The fireplace area must be kept clear and free of combustible materials, gasoline or other flammable vapours and liquids. The flow of combustion and ventilation air must not be obstructed.

1. In order to properly clean the burner and oxygen depletion sensor system, remove the logs to expose both assemblies.
2. Keep the control compartment, logs, burner, air shutter opening and the area surrounding the logs clean by vacuuming or brushing, *at least once a year*.
3. Check to see that all burner ports are burning. Clean out any of the ports which may not be burning or are not burning properly.
4. Check to see that the pilot flame is large enough to engulf the thermocouple and thermopile and promptly ignites the main burner.
5. Replace the cleaned logs.
6. Check to see that the main burner ignites completely on all openings when the gas knob for the burner is turned on. A 5 to 10 second total light-up period is satisfactory. If ignition takes longer, consult your Napoleon® dealer / distributor.
7. If using an optional catalytic door, check that the gasketing on the sides, and top of the door is not broken or missing. Replace if necessary.

## OXYGEN DEPLETION SENSOR PILOT CLEANING

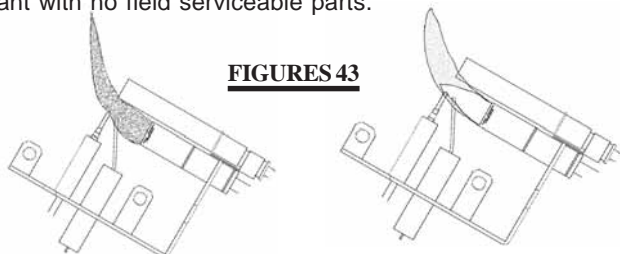
### THIS PROCEDURE MUST BE PERFORMED BY A QUALIFIED SERVICE PERSON!

Inspect the pilot for any visible contamination or debris (usually lint, pet hair, spider webs, carpet fibre, etc.) and remove.

Disconnect the pilot from the pilot tubing line. Using a  $\frac{7}{16}$ " wrench, remove the injector from the pilot housing. Blow out the housing in the same direction as the gas flow.

Re-install the injector and the pilot tube, turn on the gas and check for leaks.

If this does not improve the performance, replace the pilot with **an exact replacement**. The device is tamper resistant with no field serviceable parts.



**FIGURES 43**

CORRECT PILOT FLAME    INCORRECT PILOT FLAME

W415-0319/F/10.02.07

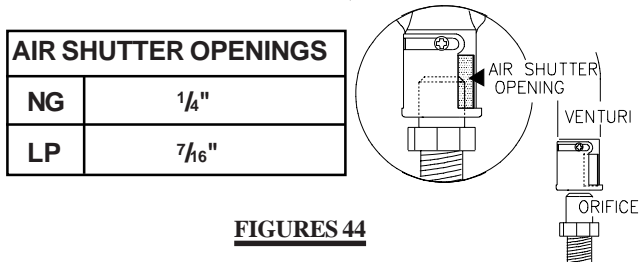
## VENTURI ADJUSTMENT

### AIR SHUTTER ADJUSTMENT MUST ONLY BE DONE BY A QUALIFIED GAS INSTALLER!

Closing the air shutter will cause a more yellow flame, but can lead to carboning. **WARNING:** Carbon can be distributed in surrounding living area if the air shutter is improperly adjusted.

Opening the air shutter will cause a more blue flame, but can cause flame lifting from the burner ports. The flame may not appear yellow immediately; allow 15 to 30 minutes for the final flame colour to be established.

Opening the air shutter will also reduce exhaust odours smelled within the room. See *Trouble Shooting Guide*.



**FIGURES 44**



# REPLACEMENTS

Contact your dealer for questions concerning prices and availability of replacement parts. Normally all parts can be ordered through your Napoleon® dealer or distributor.

**FOR WARRANTY REPLACEMENT PARTS, A PHOTOCOPY OF THE ORIGINAL INVOICE WILL BE REQUIRED TO HONOUR THE CLAIM.**

\* IDENTIFIES ITEMS WHICH ARE NOT ILLUSTRATED. FOR FURTHER INFORMATION, CONTACT YOUR NAPOLEON® DEALER.

When ordering replacement parts always give the following information:

1. MODEL & SERIAL NUMBER OF FIREPLACE
2. INSTALLATION DATE OF FIREPLACE
3. PART NUMBER
4. DESCRIPTION OF PART
5. FINISH
6. TOP OR REAR VENT

## COMPONENTS COMMON TO ALL UNITS

#	PART No.	DESCRIPTION
1*	W361-0016	GLOWING EMBERS
2*	W550-0001	CHARCOAL EMBERS
3*	GD660	STANDARD WALL SWITCH & 20FT OF WIRE
4*	W385-0245	NAPOLEON® LOGO
5	GL-634	BGD40 LOGSET
6	W135-0153	LOG#1
7	W135-0154	LOG#2
8	W135-0155	LOG#3 - PIECE A
9	W135-0156	LOG#3 - PIECE B
10	W135-0157	LOG#4
11	W135-0158	LOG#5 - PIECE A
12	W135-0159	LOG#5 - PIECE B
13	W475-0511	END FIBRE BRICK PANEL - FOR BURNER
14	W475-0512	END FIBRE BRICK PANEL - FOR BURNER
15	W475-0514	SIDE FIBRE BRICK PANEL - FOR BURNER
16	W475-0513	SIDE FIBRE BRICK PANEL - FOR BURNER
17	W080-0519	BOTTOM LOUVRE BRACKET
18	W335-0024	HOOD
19	W565-0058	CURTAIN MESH
20	W555-0033	CURTAIN ROD
21	W080-0357	CURTAIN ROD BRACKET
22	W630-0010	BLACK TASSELS
23	W500-0194	CURTAIN SUPPORT PLATE
24	W200-0114	SIDE DOOR COVER

## COMPONENTS UNIQUE TO OPEN END UNIT

25	N010-0327	SIDE DOOR HEAT SHIELD
26	W475-0517	SIDE BRICK PANEL - FOR WALL
27	W500-0192	SIDE BRICK PANEL RETAINER
28	W335-0027	SHORT HOOD
29	W565-0060	SHORT CURTAIN MESH
30	W555-0039	SHORT CURTAIN ROD
31	N010-0310	END LOUVRE HOOD w/ LOUVRE BRACKETS
32	W585-0126	END DOOR HEAT SHIELD
33	N010-0323	END DOOR COVER
34	W500-0192	END BRICK PANEL RETAINER
35	W475-0516	END BRICK PANEL
32	W585-0126	END DOOR HEAT SHIELD

## COMPONENTS UNIQUE TO SEE-THRU UNIT

33	N010-0323	END DOOR COVER
34	W500-0192	END BRICK PANEL RETAINER
35	W475-0516	END BRICK PANEL
28	W335-0027	SHORT HOOD

## COMPONENTS UNIQUE TO PENINSULA UNIT

29	W565-0060	SHORT CURTAIN MESH
30	W555-0039	SHORT CURTAIN ROD
31	N010-0310	END LOUVRE HOOD w/ LOUVRE BRACKETS
32	W585-0126	END DOOR HEAT SHIELD
33	N010-0323	END DOOR COVER
34	W500-0192	END BRICK PANEL RETAINER
35	W475-0516	END BRICK PANEL
28	W335-0027	SHORT HOOD

## COMPONENTS UNIQUE TO ISLAND UNIT

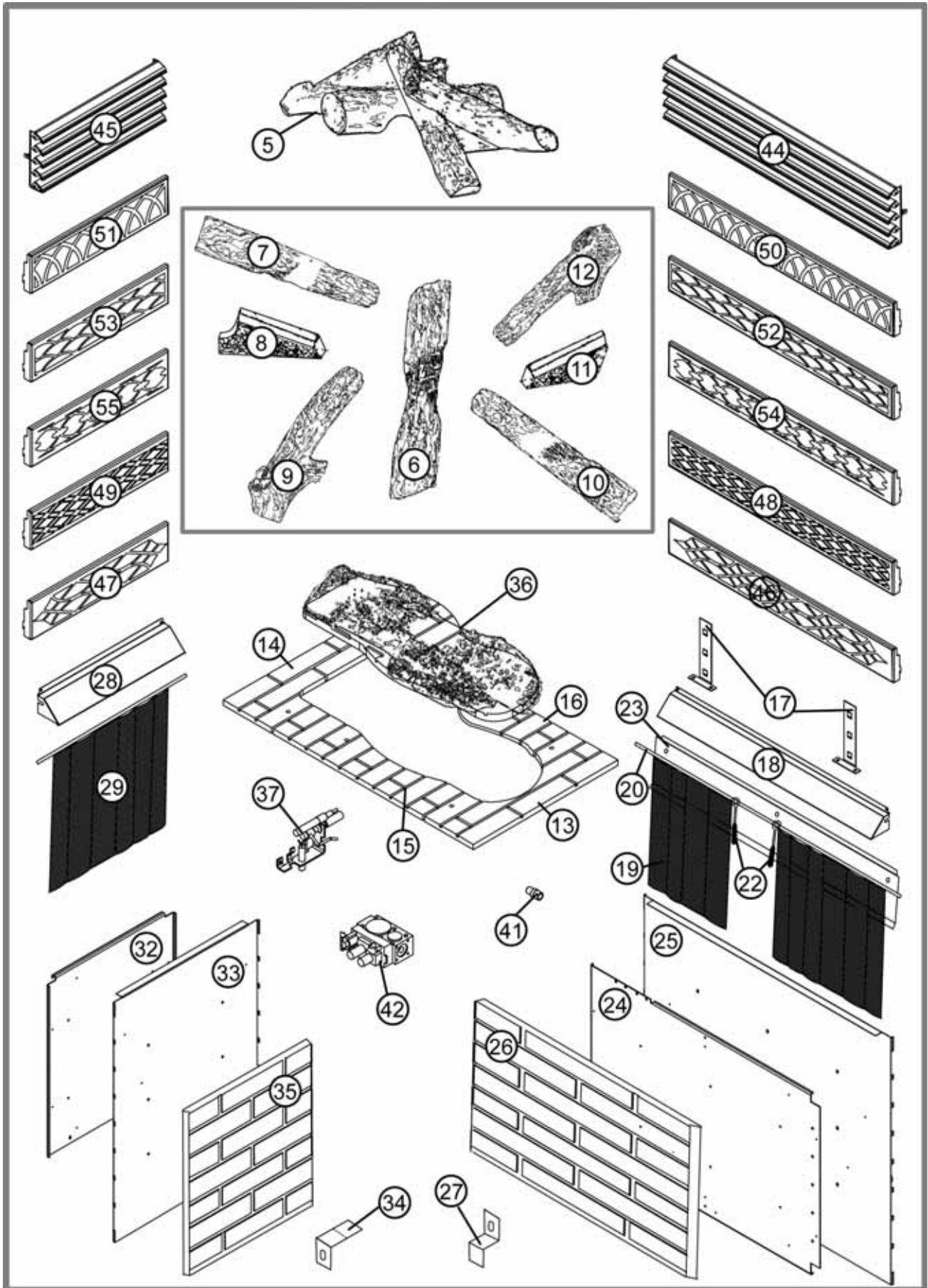
29	W565-0060	SHORT CURTAIN MESH
30	W555-0039	SHORT CURTAIN ROD
31	N010-0310	END LOUVRE HOOD w/ LOUVRE BRACKETS

## BURNER COMPONENTS

36	W010-0997	REPLACEMENT BURNER
37	W662-0001	NATURAL GAS OXYGEN DEPLETION SENSOR SYSTEM
37	W662-0002	PROPANE GAS OXYGEN DEPLETION SENSOR SYSTEM
38*	W660-0005	BURNER ON/OFF SWITCH
39*	W680-0004	THERMOPILE
40*	W357-0001	PIEZO IGNITER
41	W455-0026	#38 NATURAL GAS BURNER ORIFICE
41	W455-0059	#53 PROPANE GAS BURNER ORIFICE
42	W725-0030	NATURAL GAS VALVE
42	W725-0031	PROPANE GAS VALVE

## ACCESSORIES

43*	BGDELK	END LOUVRE KIT - BLACK
43*	BGDELPB	END LOUVRE KIT - POLISHED BRASS
43*	BGDELAB	END LOUVRE KIT - ANTIQUE BRASS
43*	BGDELSS	END LOUVRE KIT - STAINLESS STEEL
44	L36K	LOUVRE KIT - UPPER & LOWER - BLACK
45*	ELB40K	END LOUVRE KIT - BLACK
46	HOIG-1	HERITAGE ORNAMENTAL INSET-GOLD PLATED
46	HOIKG-1	HERITAGE ORNAMENTAL INSET-BLACK GOLD PLATED
46	HOIBC-1	HERITAGE ORNAMENTAL INSET-BRUSHED COPPER PLATED
46	HOIBG -1	HERITAGE ORNAMENTAL INSET-BRUSHED GOLD PLATED
47*	HOIG -1	END HERITAGE ORNAMENTAL INSET-GOLD PLATED
47*	EHOIKG-1	END HERITAGE ORNAMENTAL INSET-BLACK GOLD PLATED
47*	EHOIBC-1	END HERITAGE ORNAMENTAL INSET-BRUSHED COPPER PLATED
47*	EHOIBG -1	END HERITAGE ORNAMENTAL INSET - BRUSHED GOLD PLATED
48	DOIG-1	DIAMOND ORNAMENTAL INSET - GOLD PLATED
48	DOIKG-1	DIAMOND ORNAMENTAL INSET - BLACK GOLD PLATED
48	DOIBC-1	DIAMOND ORNAMENTAL INSET - BRUSHED COPPER PLATED
48	DOIBG-1	DIAMOND ORNAMENTAL INSET - BRUSHED GOLD PLATED
49*	EDOIG-1	END DIAMOND ORNAMENTAL INSET - GOLD PLATED
49*	EDOIKG-1	END DIAMOND ORNAMENTAL INSET - BLACK GOLD PLATED
49*	EDOIBC-1	END DIAMOND ORNAMENTAL INSET - BRUSHED COPPER PLATED
49*	EDOIBG-1	END DIAMOND ORNAMENTAL INSET - BRUSHED GOLD PLATED
50	GOIG-1	GOTHIC ORNAMENTAL INSET - GOLD PLATED
50	GOIKG-1	GOTHIC ORNAMENTAL INSET - BLACK GOLD PLATED
50	GOIBC-1	GOTHIC ORNAMENTAL INSET - BRUSHED COPPER PLATED
50	GOIBG-1	GOTHIC ORNAMENTAL INSET - BRUSHED GOLD PLATED
51*	EGOIG-1	END GOTHIC ORNAMENTAL INSET - GOLD PLATED
51*	EGOIKG-1	END GOTHIC ORNAMENTAL INSET - BLACK GOLD PLATED
51*	EGOIBC-1	END GOTHIC ORNAMENTAL INSET - BRUSHED COPPER PLATED
51*	EGOIBG-1	END GOTHIC ORNAMENTAL INSET - BRUSHED GOLD PLATED
52	SOIG-1	SEASHELL ORNAMENTAL INSET - GOLD PLATED
52	SOIKG-1	SEASHELL ORNAMENTAL INSET - BLACK GOLD PLATED
52	SOIBC-1	SEASHELL ORNAMENTAL INSET - BRUSHED COPPER PLATED
52	SOIBG-1	SEASHELL ORNAMENTAL INSET - BRUSHED GOLD PLATED
53*	ESOIG-1	END SEASHELL ORNAMENTAL INSET - GOLD PLATED
53*	ESOIKG-1	END SEASHELL ORNAMENTAL INSET - BLACK GOLD PLATED
53*	ESOIBC-1	END SEASHELL ORNAMENTAL INSET - BRUSHED COPPER PLATED
53*	ESOIBG-1	END SEASHELL ORNAMENTAL INSET - BRUSHED GOLD PLATED
54	EOIG-1	ECLIPSE ORNAMENTAL INSET - GOLD PLATED
54	EOIKG-1	ECLIPSE ORNAMENTAL INSET - BLACK GOLD PLATED
54	EOIBC-1	ECLIPSE ORNAMENTAL INSET - BRUSHED COPPER PLATED
54	EOIBG-1	ECLIPSE ORNAMENTAL INSET - BRUSHED GOLD PLATED
55*	EEOIG-1	END ECLIPSE ORNAMENTAL INSET - GOLD PLATED
55*	EEOIKG-1	END ECLIPSE ORNAMENTAL INSET - BLACK GOLD PLATED
55*	EEOIBC-1	END ECLIPSE ORNAMENTAL INSET - BRUSHED COPPER PLATED
55*	EEOIBG-1	END ECLIPSE ORNAMENTAL INSET - BRUSHED GOLD PLATED
56*	W323-K	STANDARD DOOR ASSEMBLY - FOR FACE C/W HOOD
57*	W324-K	STANDARD DOOR ASSEMBLY - FOR END C/W HOOD



# TROUBLE SHOOTING GUIDE

SYMPTOM	PROBLEM	TEST SOLUTION
---------	---------	---------------

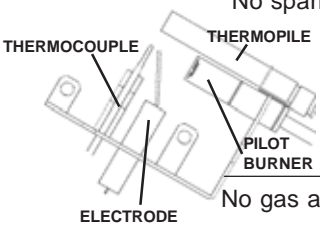
Main burner goes out; pilot stays on.	Pilot flame is not large enough or not engulfing the thermopile	<ul style="list-style-type: none"> <li>- service or replace Oxygen Depletion Sensor System</li> <li>- correct piping and/or regulator to provide correct pressure</li> </ul>
	Thermopile shorting	<ul style="list-style-type: none"> <li>- clean thermopile connection to the valve. Reconnect.</li> <li>- replace Oxygen Depletion Sensor System / valve.</li> </ul>
	Remote wall switch wire is too long; too much resistance in the system.	<ul style="list-style-type: none"> <li>- shorten wire to correct length or wire gauge.</li> </ul>
	Faulty thermostat or switch.	<ul style="list-style-type: none"> <li>- replace.</li> </ul>

Main burner goes out; pilot goes out.	Insufficient air supply	<ul style="list-style-type: none"> <li>- open window or door. (Use one of the methods described in ANSI Z223.1 Section 5.3 or the applicable local code.)</li> </ul>
	Out of propane gas.	<ul style="list-style-type: none"> <li>- fill the tank.</li> </ul>
	Pilot flame is not large enough. (Supply pressure too low.)	<ul style="list-style-type: none"> <li>- service or replace Oxygen Depletion Sensor System</li> <li>- correct piping and / or regulator to provide correct pressure.</li> </ul>

Pilot goes out when the gas knob is released.  <b>The gas valve has an interlock device which will not allow the pilot burner to be lit until the thermocouple has cooled. Allow approximately 60 seconds for the thermocouple to cool.</b>	System is not correctly purged.	<ul style="list-style-type: none"> <li>- purge the gas line. If a glass door has been installed, ensure that the door is open or removed prior to purging.</li> </ul>
	Out of propane gas.	<ul style="list-style-type: none"> <li>- fill the tank.</li> </ul>
	Pilot flame is not large enough. (Supply pressure too low.)	<ul style="list-style-type: none"> <li>- service or replace Oxygen Depletion Sensor System</li> </ul>
	Thermocouple shorting / faulty.	<ul style="list-style-type: none"> <li>- loosen and tighten thermocouple.</li> <li>- clean thermocouple and valve connection.</li> <li>- replace Oxygen Depletion Sensor System</li> <li>- test and replace valve.</li> </ul>
	Faulty valve.	<ul style="list-style-type: none"> <li>- replace.</li> </ul>

Pilot burning; no gas to main burner; gas knob is on 'HI'; wall switch / thermostat is on.	Thermostat or switch is defective.	<ul style="list-style-type: none"> <li>- connect a jumper wire across the wall switch terminals; if main burner lights, replace switch / thermostat.</li> </ul>
	Wall switch wiring is defective.	<ul style="list-style-type: none"> <li>- disconnect wires from valve. Connect a jumper wire across terminals 1 &amp; 3; if the main burner lights, check the wires for defects and / or replace wires.</li> </ul>
	Main burner orifice is plugged.	<ul style="list-style-type: none"> <li>- remove stoppage in orifice.</li> </ul>
	Faulty valve.	<ul style="list-style-type: none"> <li>- replace.</li> </ul>

Pilot will not light.	Out of propane gas	<ul style="list-style-type: none"> <li>- fill the tank.</li> </ul>
	No spark at pilot burner	<ul style="list-style-type: none"> <li>- check if pilot can be lit by a match</li> <li>- check that the wire is connected to the push button ignitor.</li> <li>- check if the push button ignitor needs tightening.</li> <li>- replace the wire if the wire insulation is broken or frayed.</li> <li>- replace the electrode if the ceramic insulator is cracked or broken.</li> <li>- replace the push button ignitor.</li> </ul>
	No gas at the pilot burner	<ul style="list-style-type: none"> <li>- check that the manual valve is turned on.</li> <li>- check the pilot orifice for blockage.</li> <li>- replace the valve / Oxygen Depletion Sensor System.</li> <li>- call the gas distributor.</li> </ul>



SYMPTOM	PROBLEM	TEST SOLUTION
Pilot goes out while standing; Main burner is in 'OFF' position.	Gas piping is undersized.	<ul style="list-style-type: none"> <li>- turn on all gas appliances and see if pilot flame flutters, diminishes or extinguishes, especially when main burner ignites. Monitor appliance supply working pressure.</li> <li>- check if supply piping size is to code. Correct all undersized piping.</li> </ul>
Flames are consistently too large or too small. Carboning occurs.	Unit is over-fired or under-fired.	<ul style="list-style-type: none"> <li>- check pressure readings:</li> </ul> <p>Inlet pressure can be checked by turning screw (A) counter-clockwise 2 or 3 turns and then placing pressure gauge tubing over the test point. Check with burner operating on "HI". Gauge should read 7" (minimum 4.5") water column for natural gas or 13" (11" minimum) water column for propane.</p> <p>Outlet pressure can be checked the same as above using screw (B). Check with burner operating on "HI". Gauge should read 3.5" water column for natural gas or 10" water column for propane.</p> <p><b>AFTER TAKING PRESSURE READINGS, BE SURE TO TURN SCREWS CLOCKWISE FIRMLY TO RESEAL. DO NOT OVERTORQUE.</b></p> <p>Leak test with a soap and water solution.</p>
Carbon is being deposited on logs or combustion chamber surfaces.	Air shutter has become blocked	<ul style="list-style-type: none"> <li>- ensure air shutter opening is free of lint or other obstructions.</li> </ul>
	Flame is impinging on the logs or combustion chamber.	<ul style="list-style-type: none"> <li>- check that the logs are correctly positioned.</li> <li>- open air shutter to increase the primary air. See air shutter openings, page 13.</li> <li>- check the input rate: check the manifold pressure and orifice size as specified by the rating plate values.</li> </ul>
White / grey film forms on the glass of the optional catalytic door.	Sulphur from fuel is being deposited on glass, logs or combustion chamber surfaces.	<ul style="list-style-type: none"> <li>- clean the glass with a recommended gas fireplace glass cleaner. <b>DO NOT CLEAN GLASS WHEN HOT.</b></li> </ul> <p>If deposits are not cleaned off regularly, the glass may become permanently marked.</p>
Exhaust fumes smelled in room, headaches.	Not enough combustion air.	<ul style="list-style-type: none"> <li>- increase fresh air supply. (Use one of the methods described in ANSI Z223.1 Section 5.3 or the applicable local code.)</li> </ul>
	Not enough ventilation air.	<ul style="list-style-type: none"> <li>- increase fresh air supply. (Use one of the methods described in ANSI Z223.1 Section 5.3 or the applicable local code.)</li> </ul>
	Catalytic tile is masked (contaminated by dust, paint fumes).	<ul style="list-style-type: none"> <li>- check CO output from catalytic tiles. See Maintenance Section. Replace if necessary.</li> </ul>
	Flame is impinging on the logs or combustion chamber.	<ul style="list-style-type: none"> <li>- check that the logs are correctly positioned.</li> <li>- open air shutter to increase the primary air. See air shutter openings, page 13.</li> <li>- check the input rate: check the manifold pressure and orifice size as specified by the rating plate values.</li> </ul>
Remote wall switch is in "OFF" position; main burner comes on when gas knob is turned to "ON" position.	Wall switch is mounted upside down	<ul style="list-style-type: none"> <li>- reverse.</li> </ul>
	Remote wall switch is grounding.	<ul style="list-style-type: none"> <li>- replace.</li> </ul>
	Remote wall switch wire is grounding.	<ul style="list-style-type: none"> <li>- check for ground (short); repair ground or replace wire.</li> </ul>
	Faulty valve.	<ul style="list-style-type: none"> <li>- replace.</li> </ul>



