

CRYSTORAMA

1958

95 Cantiague Rock Road, Westbury NY 11590
 ph:516.931.9090 fax:516.931.1254
 info@crystorama.com www.crystorama.com

MODEL#:9502 ASSEMBLY AND DRESSING INSTRUCTIONS



All electrical components must be installed by a licensed electrician in accordance with the National Electric Code and the appropriate local electrical codes.

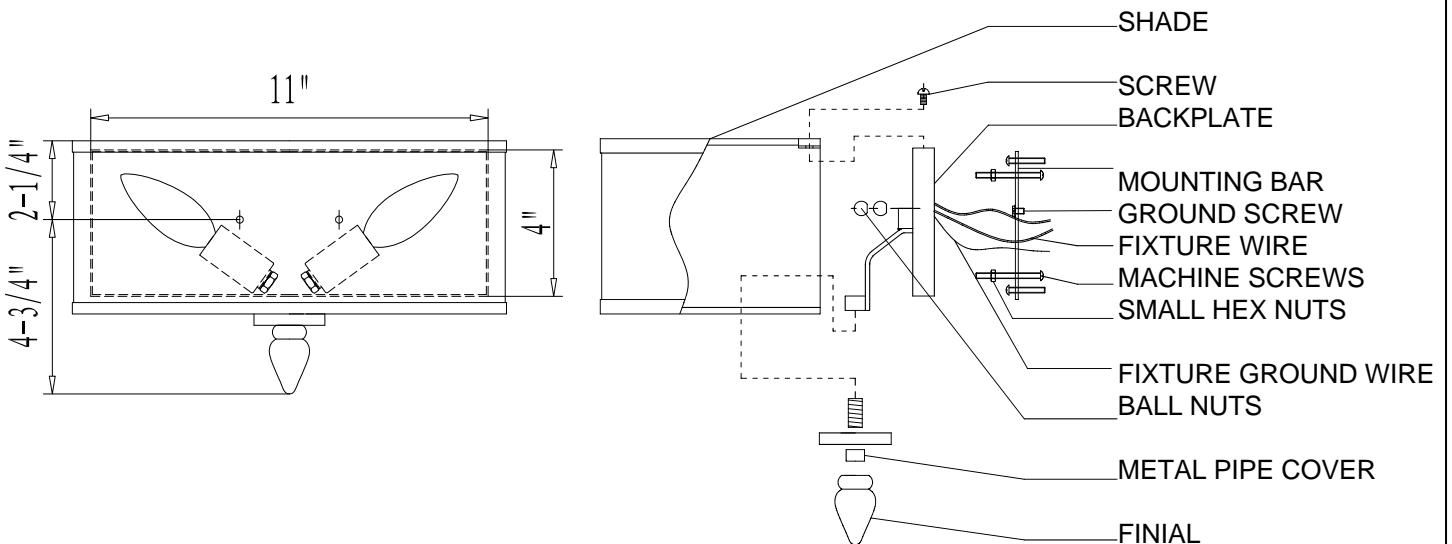
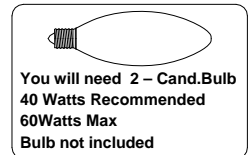

BACKPLATE DIMENSION IS : (W:11"*H:4"*E:5/8")

SHADE DIMENSION IS :(W:12"*H:4-3/4"*E:6")

2012-02-22