

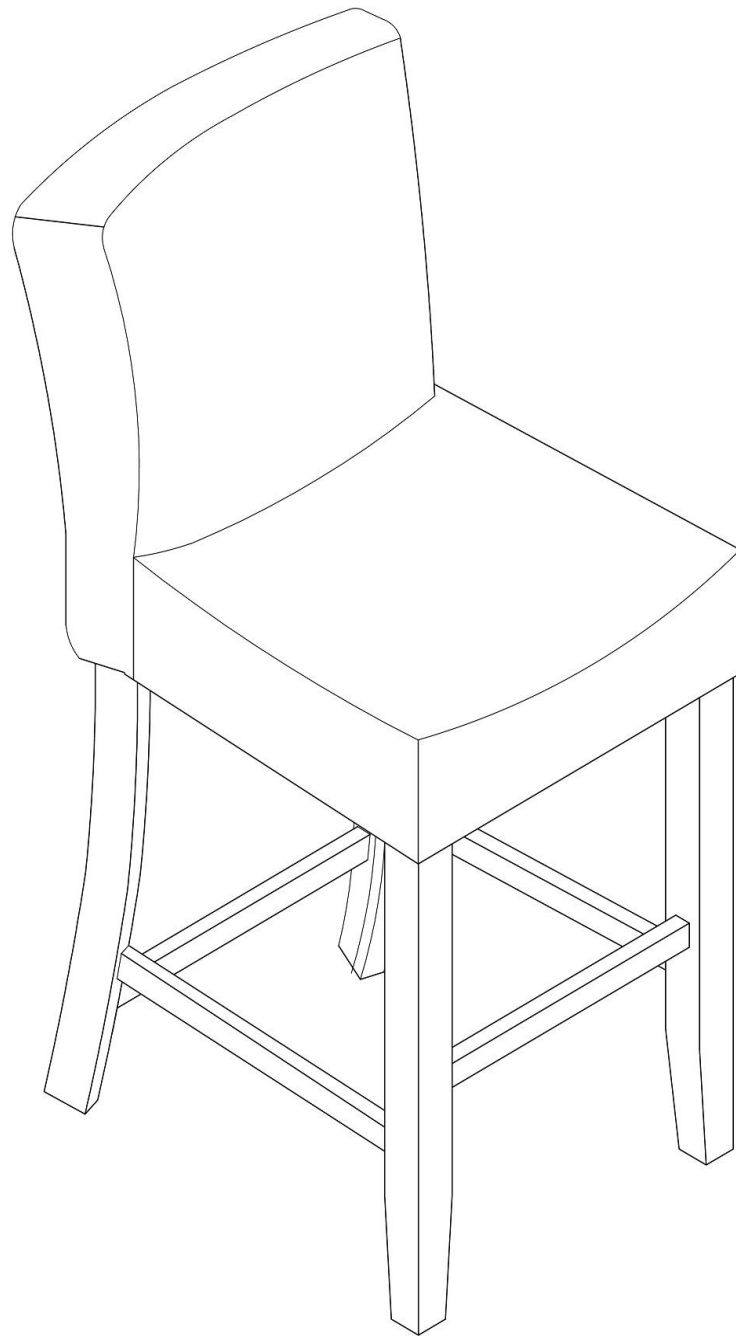

# Assembly Instructions

**Caution: You must read this before you proceed.**





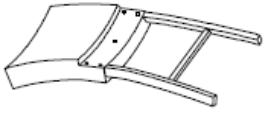
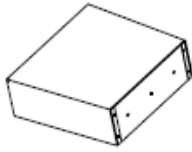
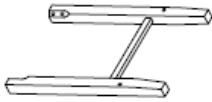

## Bar/ Counter Chair



## Parts List

Part NO.	Picture	Description	QTY
A		Chair Back	1 PC
B		Chair Seat	1 PC
C		Front Leg Frame	1 PC
D		Left Side Rail(hole side as bottom side to face the floor after assembled)	1 PC
E		Right Side Rail(hole side as bottom side to face the floor after assembled)	1PC

## Hardware

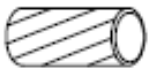
Label	Picture	Description	QTY
1		M6x80 mm Long Bolt	5 PCS
2		M6x50mm Short Bolt	6 PCS
4		Spring Washer Ring	11 PCS
3		Flat Washer Ring	11 PCS
5		Allen Key	1 PC
6		Screw (M4*38mm)	5 PCS
7		Screwdriver	Not provided
8		Positioning Dowel (M8*35mm)	3 PCS

# Assembly Preparation

Before Beginning Assembly:

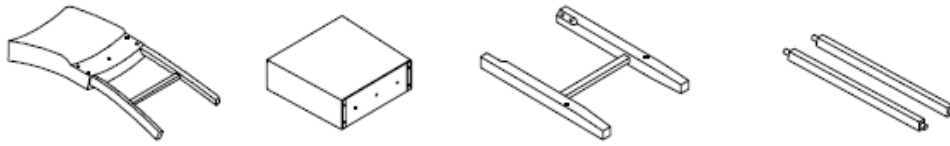

Pack A for assembling the Seat Frame (B) to the horizontal panel with two dowels of Chair Back (A) at the central point

1pc of 50mm Short Bolt +  
1pc of Flat Washer Ring +  
1pc of Spring washer + one  
Allen key



Pack B for assembling the Seat Frame (B) to the hind legs of Chair Back (A)

4pcs of 80mm Long Bolts +  
4pcs of Spring Washer  
Rings + 4pcs of Flat  
Washer Rings

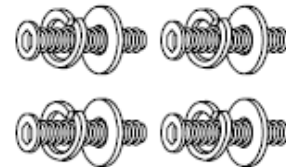

Pack C for assembling the Seat Frame(B) to the Front Leg Frame (C)

4pcs of 50mm Short Bolts +  
4pcs of Flat Washer Rings  
+ 4pcs of Spring Washer  
Rings

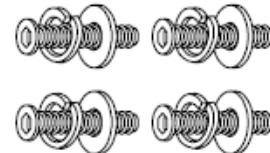

Pack D for assembling the Left Side Rails (D)&Right Side Rails(E)to the Front Leg Frame (C )

2 pcs M4\*38mm Screws



Pack E for assembling the Left Side Rails (D)&Right Side Rails(E) to the Chair Back (A)

2 pcs M4\*38mm Screws



- Read instructions, cover to cover-



- Have 2 adults on hand for assembly-



- Do not assemble on flooring or carpet-



- Assemble on a clean non-marring surface (packing foam)-



- Save all packaging until finished-

# Assembly Steps

## Step 1

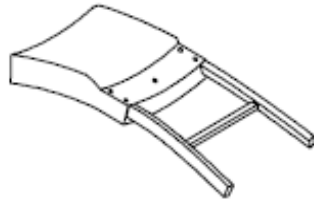

A. Chair Back

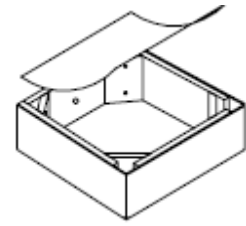

B. Chair Seat with Black Calico/ Velcro Tapes

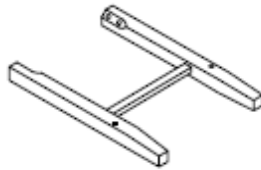

C. Front Leg's Frame

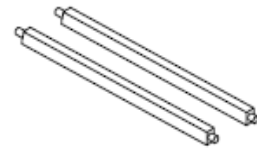

D. Left Side Rail & E. Right Side Rail

Place the Chair Back (A) and Chair Seat (B) on a soft surface to avoid any scratches or damages to the product.

REMOVE the Seat Base Cover from the underside of the Chair Seat (B), take out the left side rail(D)&right side rail(E) and hardware.

## Step 2

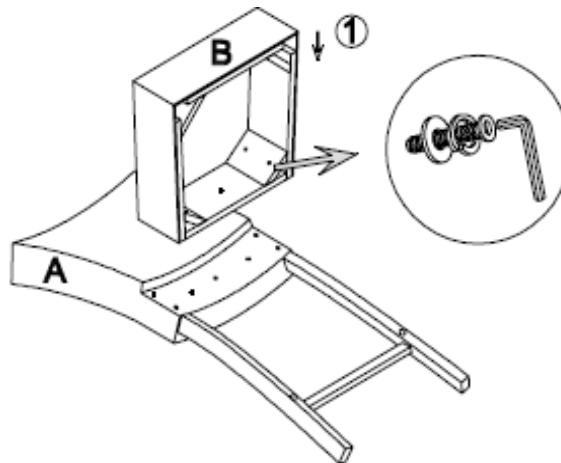
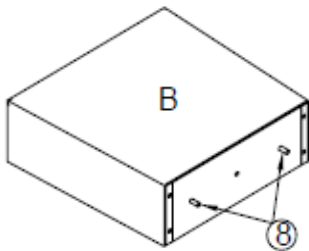

Put the Chair Back (A) onto a flat table top-like a waist high table/top.

Insert the positioning dowels (8) on the Chair Seat Back Panel (B).

Align the holes on Chair Back (A) with the holes on Chair Seat Frame (B).

Use your left hand to push the seat frame floorwards, depicted by Arrow 1.

This action helps to ensure the Chair Seat (B) is pressed towards to the Chair Back (A) with no gap between these.

Then, lock the middle mounting point by using Hardware Pack A and the corner mounting points by using Hardware Pack B with the Allen Key.

**WARNING!! DO NOT OVER TIGHTEN. OVER TIGHTENING COULD LEAD TO DAMAGE OF THE PRODUCT. TIGHTEN ONLY UNTIL SECURE AND STABLE.**

### Step 3

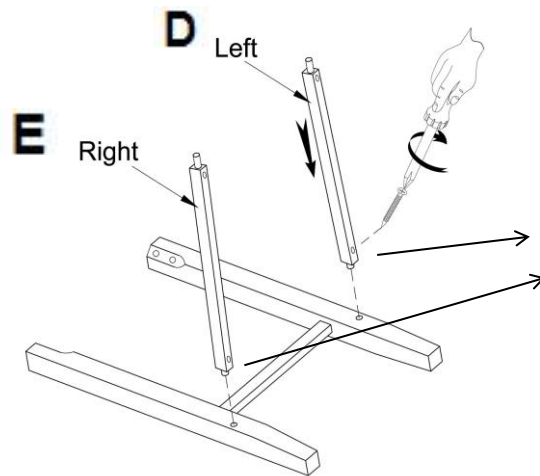

The end labeled with "Front" should insert to the Front Leg Frame (C)

Insert the Left side rail(D)&Right side rail(E)into the oval housing of Front Leg Frame (C) as shown above.

Then, use the hardware of Part D to attach the the Left side rail(D)&Right side rail(E)to the Front Leg Frame (C).

**WARNING!! DO NOT OVER TIGHTEN. OVER TIGHTENING COULD LEAD TO DAMAGE OF THE PRODUCT. TIGHTEN ONLY UNTIL SECURE.**

### Step 4

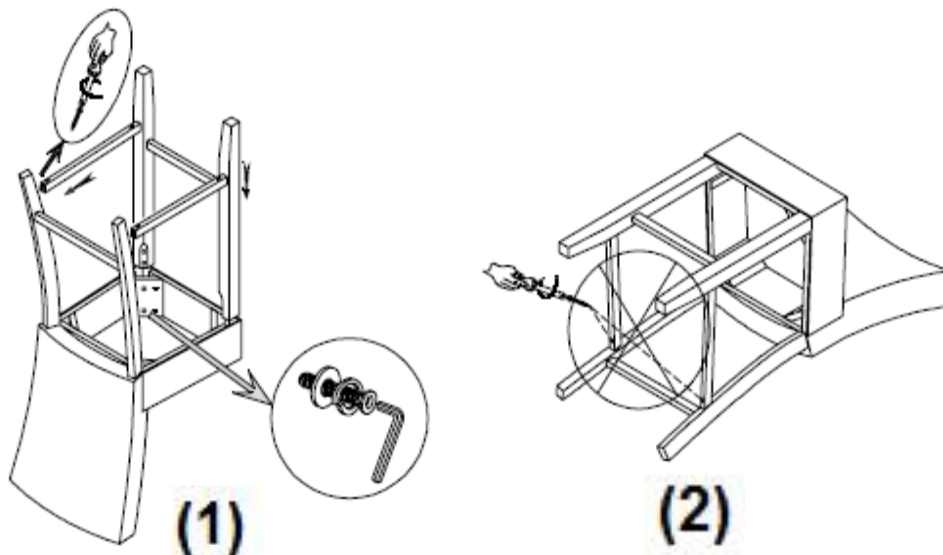

Next, place the chair onto the side of a table as seen in Picture 1.

You will now have the chair bottom and legs facing skywards.

Insert the assembled unit from Step 3 into the Chair Seat (B).

**WARNING!! DO NOT POSITION THE FRONT LEG AS SHOWN IN PICTURE 2 . THIS PICTURE SHOWS THE CHAIR BACK STAYS AGAINST THE GROUND and THE LEGS HORIZONTAL IN MIDAIR.**

Use "PACK C" to assemble the Front Leg Frame (C) to the Seat Frame (B),  
Then use "PACK E" to hold the Side Rails with the Front and Hind Legs.

**WARNING!! DO NOT OVER TIGHTEN. OVER TIGHTENING COULD LEAD TO DAMAGE OF THE PRODUCT.  
TIGHTEN ONLY UNTIL SECURE AND STABLE.**

## Step 5

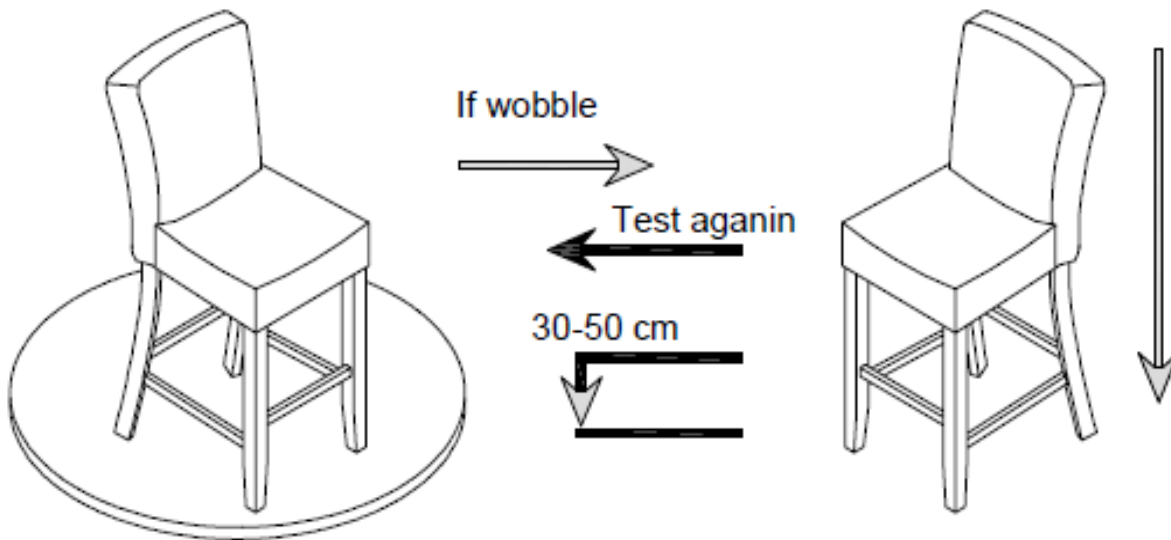

Place the chair on a **LEVEL SURFACE** to see if it wobbles.  
If it wobbles, lift the chair to some 30cm to 50cm height from the ground.  
Keep your feet and toes well away from the drop zone.  
Drop the chair freely and vertically with the four legs, hitting the ground, at the same time.  
This **Drop Test** will help to ensure that all the bolts and gaps to all reach full alignment status.  
Test again for evenness on a **LEVEL SURFACE**.  
If no wobbles found, proceed to tighten all the bolts.  
**CAUTION** : When tightening these bolts, tighten sequentially.  
**DO NOT** tighten any screw fully and then towards the next one.  
This would cause the frame to warp.  
If there is still wobbles, loosen the bolts and execute this same drop tests.  
**WARNING!! IF CHAIR IS NOT STABLE , IT COULD LEAD TO DAMAGING THE PRODUCT.**

## Step 6

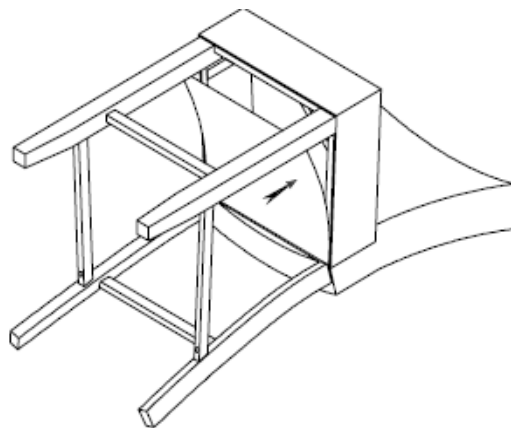

Place the Seat Base Cover back underneath the chair seat (as shown in picture) from where it was removed from originally.  
Smooth down with your hand on the velcro tapes on all 4 sides at the edge of the seat box.  
Turn the chair right way up, it is now ready for use.

## Care & Maintenance



- Do not put hot items directly on furniture surface



- Do not clean furniture with harsh cleansers or polish.



- Do not place furniture under direct sunlight.



- Do not place furniture near heating or cooling vents.



- Do not write on furniture without a padded barrier to protect the surface.



- Do not place furniture outside . For indoor use only .



- Not for commercial use. For residential use only .



- Stains may be removed with mild soap solution and damp cloth.



- Children should not climb or jump on the furniture.



- Dust and pick-up spills using a clean, non-colored, lint-free cloth .