

Specification Data

Panasonic Ventilation Fan



FV-15VQ4 (150 CFM)

Description

Ventilating fan shall be Low Noise ceiling mount type rated for continuous run. Fan shall be ENERGY STAR rated and certified by the Home Ventilating Institute (HVI). Evaluated by Underwriters Laboratories and conform to both UL and cUL safety standards.

Motor/Blower:

- Four-pole totally enclosed condenser motor rated for continuous run.
- Power Rating shall be 120 volts and 60 Hz.
- Fan shall be UL listed for tub/shower enclosure when used with a GFCI branch circuit wiring.
- Motor equipped with thermal-cutoff fuse.
- Removable with permanently lubricated plug-in motor.

Housing:

- Rust proof paint, galvanized steel body.
- Detachable 6" diameter duct adapter.
- Built in backdraft damper.
- Expandable extension brackets up to 24".
- Double hanger bar system allowing for ideal positioning.

Grille:

- Attractive design using PP material.
- Attaches directly to housing with torsion springs.

Warranty:

- The factory warranty shall be a minimum of 3 years limited warranty on parts.

Typical Specifications:

Ventilating fan shall be of the ceiling mount, ENERGY STAR rated type, with no less than 150 CFM and no more than 0.6 sone as certified by the Home Ventilating Institute (HVI) at 0.1 static pressure in inches water gauge. Power consumption shall be no greater than 31.4 watts and ENERGY STAR rated with efficiency rating of no less than 4.8 CFM/watt. The motor shall be totally enclosed, four pole condenser type engineered to run continuously. Power rating shall be 120v/60Hz. Duct diameter shall be no less than 6". Fan shall be UL and cUL listed for tub/shower enclosure when used with GFCI branch circuit wiring. Fan shall be California Title-24 compliant.

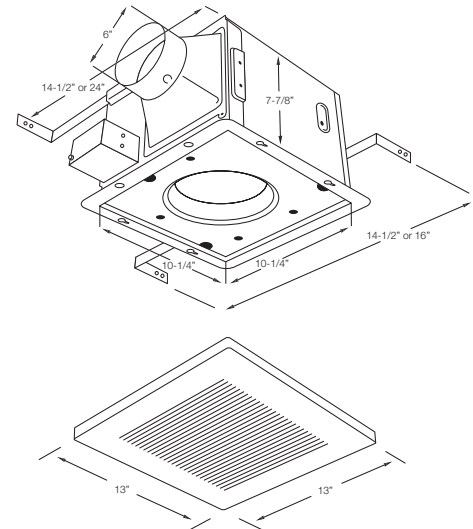

Fan Curve FV-15VQ4

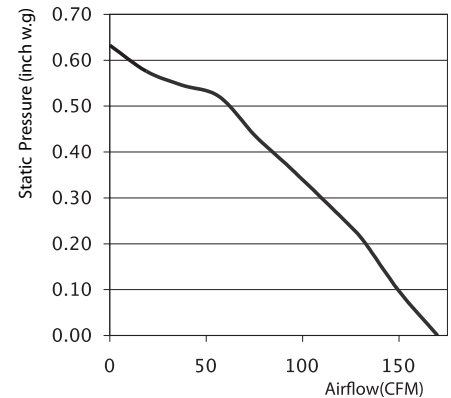

Specifications:		
	FV-15VQ4	
Static Pressure in inches w.g.	0.1	0.25
Air Volume (CFM)	150	123
Noise (sones)	0.6	NA
Power Consumption (watts)	31.4	30.2
Energy Efficiency: CFM/Watt	4.8	4.1
Speed (RPM)	673	873
ENERGY STAR Rated	Yes	
Washington State VIAQ Code	Yes	

As of 11/06

For Complete Installation Instructions Visit www.panasonic.com/building



Model	Quantity	Comments	Project:
			Location:
			Architect:
			Engineer:
			Contractor:
			Submitted by:
			Date: