

Apply stickers on all visible cam joint faces to cover the connector faces, after assembly.

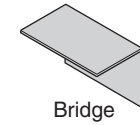

CAM LOCK NOTE:

If cam lock is installed high on the surface, tap it down flush with the surface. If that doesn't work, replace part.

If cam lock is installed low into the surface, screw cam pin out to extend the length of the cam pin.

1

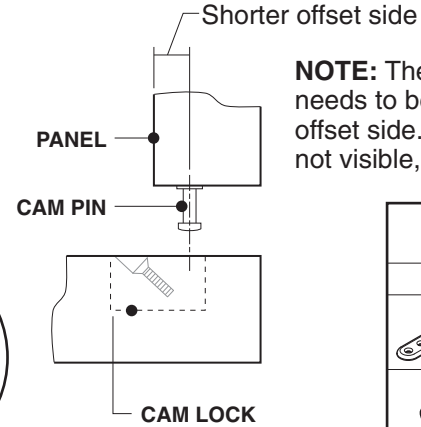
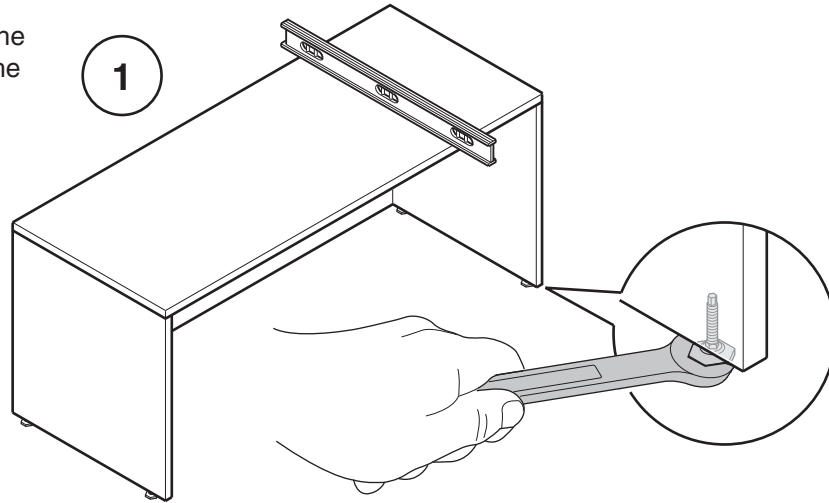

NOTE: The cam pin is offset and needs to be installed on the shorter offset side. If the screw heads are not visible, turn the panel 180°.

Hardware		
ITEM		No.
	Support Plate	4
	Screw #10 x 1"	16
	Mending Plate	2
	Screw #8 x 5/8"	4

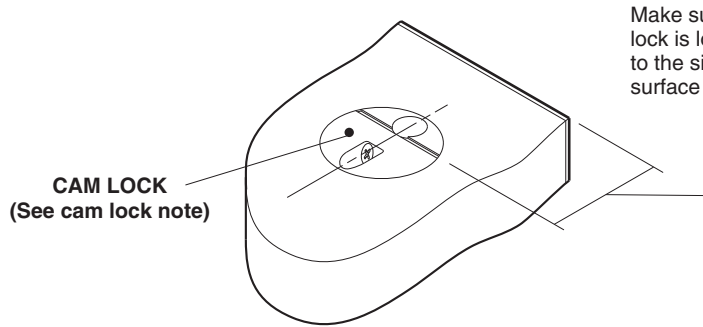

Make sure the cam lock is located parallel to the side of the surface as shown.

2

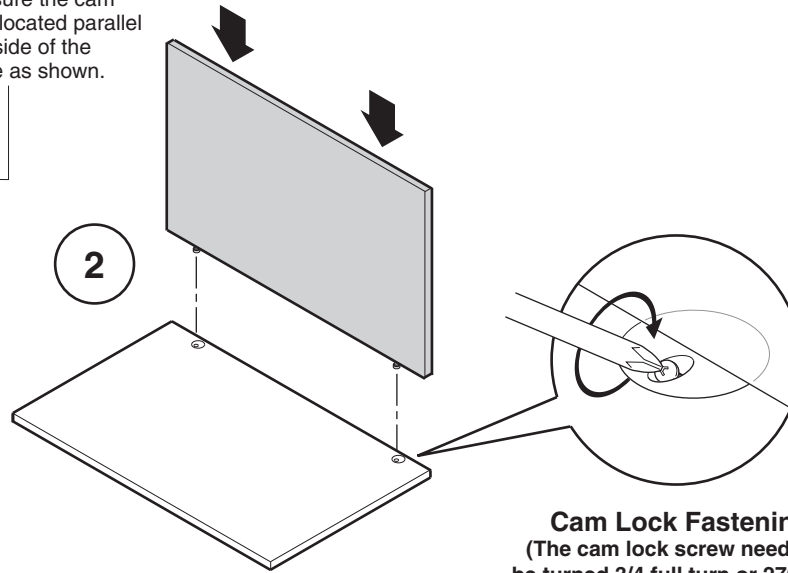

Cam Lock Fastening
(The cam lock screw needs to be turned 3/4 full turn or 270° for complete engagement.)

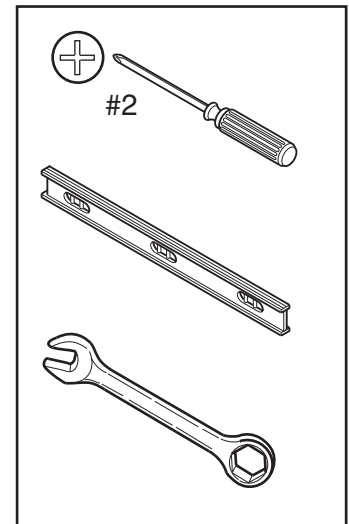

If you have a problem, question, or request, call your local dealer, or Steelcase Line 1 at **888.STEELCASE** (888.783.3522) for immediate action by people who want to help you.
(Outside the U.S.A., Canada, Mexico, Puerto Rico, and the U.S. Virgin Islands, call: 1.616.247.2500)
Or visit our website: www.steelcase.com

© 2012 Steelcase Inc.
Grand Rapids, MI 49501
U.S.A.

Printed in U.S.A.

3

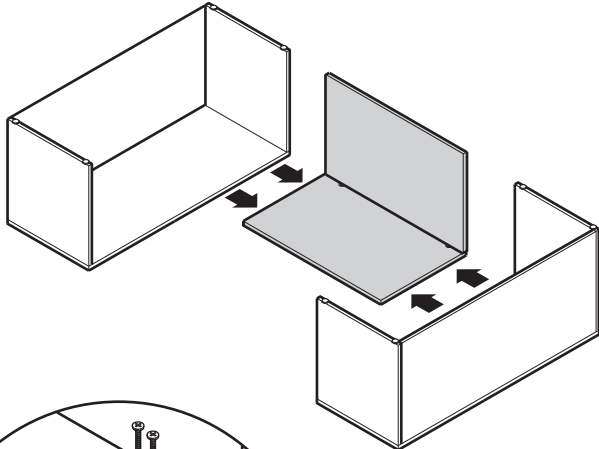

SCREW #10 X 1"

SUPPORT PLATE

4

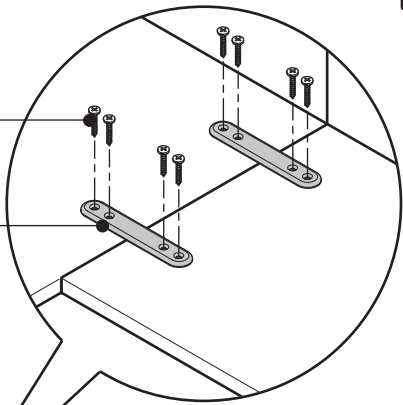

5

