

OWNER'S MANUAL

& Assembly Instructions



EWC-25

Wide Combo Bench W/Leg Developer

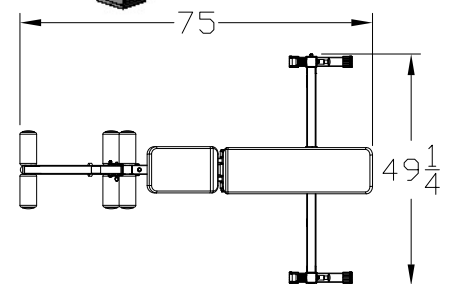

L75 X W 49 1/4 X H57 1/4

WARNING

Read and understand the Owner's Manual, all danger, warning and caution labels before using this equipment.

EWC-25_Rev0
Revision Date 3-28-12

Table of Contents



DANGER, WARNING, & CAUTION LABELS INFORMATIONPage 3-4

IMPORTANT SAFETY INSTRUCTIONS.....Page 5

PREPARATION & ASSEMBLY TIPSPage 6

ASSEMBLY INSTRUCTIONS – STEP 1Page 7

ASSEMBLY INSTRUCTIONS – STEP 2Page 8

ASSEMBLY INSTRUCTIONS – STEP 3Page 9

PARTS LIST Page 10

EXPLODED VIEW Page 11

BASIC EXERCISE GUIDE.....Page 12-14

NOTES..... Page 15

WARRANTY Page 16

TuffStuff Fitness Equipment Inc. continually engages in research related to product improvements. Please take the time to carefully read through this manual thoroughly. Instructions contained in this manual are not intended to cover all details or variations possible with Gladiator equipment, or to cover every contingency that may be met in conjunction with assembly, installation, operation, maintenance or troubleshooting of the equipment. Eventhough we have prepared this manual with extreme care, neither the manufacturer nor the author can accept responsibility for any errors in, or omission from, the information given. Should additional information be required, or should situations arise that are not covered by this manual, the matter should be directed to Customer Service at TuffStuff Fitness Equipment Inc. in Chino, California.

Carefully read ALL Danger, Warning & Caution labels posted on the machine

BNH2917

SCHEDULE
Replacement Parts

Recommended TuffStuff Parts (replace or as needed)	12-MONTH	18-MONTH	21-MONTH	24-MONTH
	BNH4175: Plastic tube guide		X	
GENERIC: Rubber grips			X	
GENERIC: Upholstery		X		
BNH4148: Turn pull-pin with knob			X	
BNH4174: Pull-pin			X	
BNH0043: Foam roll 7x4x1		X		
GENERIC: Decals				
BNH4172: Olympic spring clip		X		

Use only genuine TuffStuff parts.
Failure to do so will void warranty
and could result in personal injury.
Warranty period on all parts are
one (1) year from date of purchase.

TuffStuff Fitness Equipment Inc.
Chino, CA 91710, USA

BNH2917

BNH2906 Qty. 2

! DANGER
Do Not REMOVE
This Safety Bolt.
BNH2906

BNH2902 Qty. 2

! DANGER

CHECK retaining nut.
Must be fully fastened or
could cause the pin to pull
loose and disengage.
BNH2902

BNH2903

! DANGER
Use this equipment
ONLY for its
intended purpose.
If you are unfamiliar
with the equipment or
procedure, refer to your
Owner's Manual or
call TuffStuff at
888-884-8275.
Failure to comply could result
in serious injury or death.
BNH2903

BNH2919

BNH2914

BNH2918



TuffStuff Fitness Equipment. Inc.
13971 Norton Avenue, Chino, CA 91710, USA
PH: 909-629-1600 FX: 909-629-4967
service@tuffstuff.net www.tuffstuffdirectonline.com

GLADIATOR SERIES
Serial # GLA-00-0000

TO LOOSEN
AND PULL TO
RELEASE

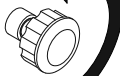

TO TIGHTEN
AND SECURE

! CAUTION

CHECK
Pull-pin is fully
engaged in the hole
& knob is tightened
before use.

BNH2914



Carefully read ALL Danger, Warning & Caution labels posted on the machine

BNH2915

INSPECTIONS

Recommended Inspection

Replace all parts at first signs of wear or damage.

	DAILY	WEEKLY	MONTHLY	6-MONTH
INSPECT: Links, pull-pins, snap locks, swivels, connectors, selector pin, welded-joints	X			
INSPECT: All decals		X		
CLEAN: Upholstery with lanolin-base cleaner	X			
INSPECT: All nuts and bolts (tighten if needed)		X		
INSPECT: Accessory bars, handles, rubber grips		X		
LUBRICATE: Seat sleeves, pull-pin sliding mechanism, bushings			X	
CLEAN & WAX: All powder-coat finishes				X

Use only genuine TuffStuff replacement parts. Failure to do so will void warranty and could result in serious injury or death.

TuffStuff Fitness Equipment Inc.
13971 Norton Avenue
Chino, CA 91710, USA
BNH2915

BNH2916 Qty. 2

IMPORTANT

For smooth performance, lubricate all gliding surfaces with silicone spray lubricant.
BNH2916

BNH2912 Qty. 2

CAUTION

CHECK
Pull-pin is fully engaged in the hole before use.
BNH2912

BNH2905 Qty. 2

DANGER

Must use **SPOTTERS/HELPERS** to assist you with this equipment. Failure to do so could result in serious injury or even death.
BNH2905

BNH2907

WARNING

Serious injury or death can occur if these rules are not followed:

1. **Read and Understand** the Owner's Manual, all danger, warning and caution labels before using this equipment. If you still need help, hire a Certified Trainer or call TuffStuff. This equipment is for **HOME USE** only.
2. Obtain a **medical examination** before beginning any exercise program.
3. **Stop exercising** if you feel faint or dizzy. Consult a physician if you are experiencing pain.
4. **Inspect equipment** before each use for wear and tear, loose fittings & welds for cracks. Do not use equipment until repaired. Use only genuine TuffStuff parts. Failure to do so will void warranty and could result in serious injury or death.
5. Use this equipment **only for exercise(s)** shown in the Owner's Manual.
6. **Use spotters/helpers** to assist when using weights.
7. Keep body, clothing and hair clear from all moving parts. Do not attempt to free any jammed parts by yourself.
8. Children must not be allowed near this machine. Teenager must be supervised.
9. Report machine malfunction to your dealer or TuffStuff.
10. Do not remove labels. Replace if damaged.

TuffStuff Fitness Equipment Inc.
Chino, CA 91710, USA
BNH2907

BNH2916 Qty. 2

IMPORTANT

For smooth performance, lubricate all gliding surfaces with silicone spray lubricant.
BNH2916

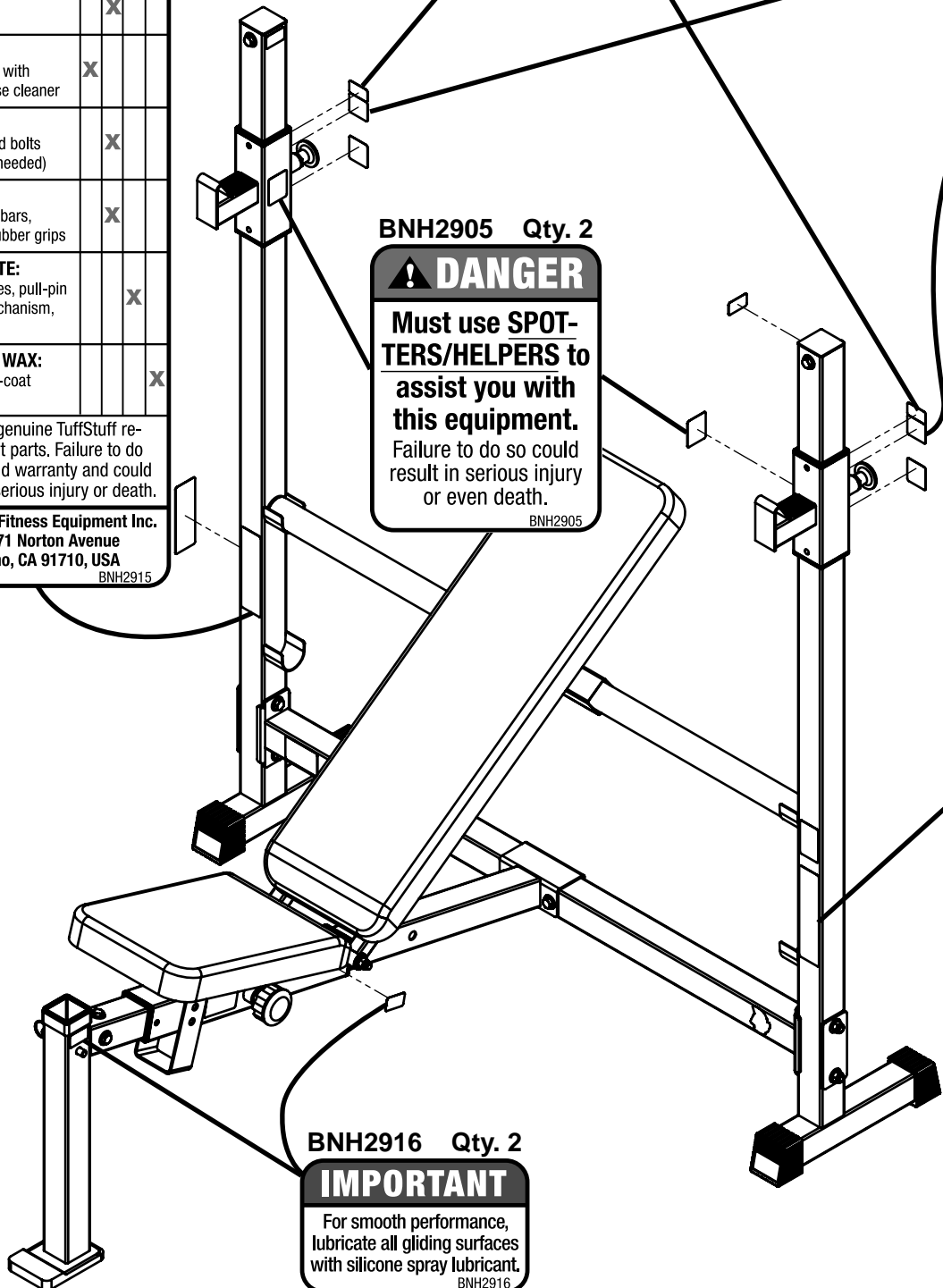

Important Safety Instructions



Before beginning any form of exercise program, it is important to get your physician approval. If you have not participated in a regular exercise program, smoke or have signs of high blood pressure, you must consult with your personal physician before performing any form of physical activities.

⚠ WARNING Before using the equipment, read and understand the Owner's Manual and all **DANGER, WARNING & CAUTION** labels posted on the machine. **SERIOUS INJURY OR DEATH CAN OCCUR IF THESE RULES ARE NOT FOLLOWED:**

1. **Inspect the equipment** before each use for wear and tear, loose fittings, and welded joints for cracks. If it appears to be inoperable or damaged, **DO NOT USE** equipment until repaired. Use only genuine TuffStuff parts. Failure to do so will void warranty and could result in serious injury or death.
2. **Children must not** be allowed near this machine. Teenager must be supervised.
3. Stop exercising if you feel faint or dizzy. Consult a physician if you are experiencing pain.
4. **Use this equipment only for exercises shown pages 12-14.**
5. **Use spotters/helpers** to assist when using weights.
6. Keep body, clothing and hair clear from all moving parts. Do not attempt to free any jammed parts by yourself.
7. Always warm-up before and cool-down after weight training. Warm-up for 10-15 minutes with stretching and cardiovascular exercises. Cool-down should include light stretching exercises for 5-15 minutes.
8. Never hold your breath – will limit the flow of oxygen to your brain and may cause dizziness. The most often used breathing pattern is inhaling during least resistance and exhaling during maximum resistance.
9. **Do not remove** any decals affixed to the machine. Replace if damaged.
10. Periodic maintenance is required to keep your equipment in safe and proper operating condition. Follow the maintenance schedule as shown in "Inspection" and "Schedule" labels.
11. Do not use accessories or accessory attachments that are not recommended by TuffStuff.
12. Make sure all pull-pins are fully engaged and secured in the holes before performing the exercises.
13. Do not use the equipment outdoors.

Personal Safety During Assembly

Before beginning assembly, it is important to take the time to read and review all of the assembly instructions provided in this manual.

Read each step in the assembly instructions and follow the steps in sequence. Do not skip ahead as you may learn later the you have to disassemble the components and that you may have damaged the components or parts.

Assemble, lubricate all moving parts, and operate the EWC-25 on a solid, level and clean surface.

Locate the unit a few feet from the walls or furniture to provide easy access.

After assembly, you should check all nuts & bolts that are wrench-tightened, and all functions to ensure correct operation. If you experience problems, first recheck the assembly instructions to locate any possible errors made during assembly. If you are unable to correct the problem(s), call the dealer from whom you made the purchase first before contacting TuffStuff Customer Service.

Obtaining Service

Please use this Owner's Manual as your guide to all parts included in your shipment. When ordering parts, you must specify the part number and description from this manual. Use only genuine TuffStuff replacement parts when servicing the equipment. Failure to do so will void your warranty and could result in serious injury or death.

For information about product operation or service:

Phone: 909-629-1600

Fax: 909-629-4967

Toll Free: 888-884-8275

E-mail: service@tuffstuff.net

Hours: M-F 8:00 – 4:30 PST

Or write to: TuffStuff Fitness Equipment Inc.

Customer Service

13971 Norton Avenue, Chino, CA 91710

Retain this Owner's Manual for future reference when ordering service or parts. To assist you better, please be prepared to provide the following information:

1. Model Number
2. Place of Purchase
3. Serial Number
4. Part # and Description

⚠ WARNING **DO NOT ATTEMPT to use over maximum weight capacity**

400 lbs **MAXIMUM LOAD**

NOTE: Maximum load capacity includes user's weight.

EWC-25 Preparation & Assembly



Thank you for purchasing the Gladiator EWC-25 Wide Combo Bench W/Leg Developer. This bench is part of the TuffStuff line of quality strength training equipment. To maximize your use of the equipment, please study the Owner's Manual thoroughly.

Required Tools

The basic tools that you will need to assemble the EWC-25 but are not limited to:

- 9/16", 1/2", 14mm, and 13mm combination wrenches
- Adjustable wrench
- Ratchet wrench with 9/16", 1/2", 14mm, and 13mm sockets
- Rubber mallet, measuring tape & utility knife

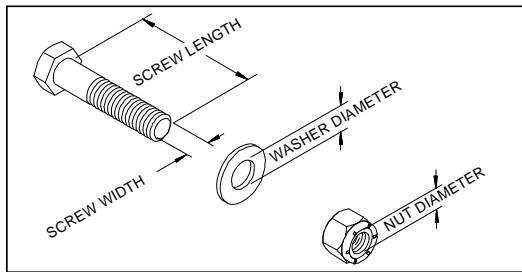

Assembly Requirements

Follow these installation requirements when assembling the EWC-25. Use the overhead view on the front page cover to layout your floor plan before assembling.

Set up the EWC-25 on a clean, solid, flat surface. A smooth, flat surface under the machine helps keep it level.

Allow ample space around the machine for safe unrestricted use and easier access.

Insert all bolts in the same direction. For aesthetic appearance, insert all bolts in the same direction unless specified (in text or illustration) to do otherwise.

Leave room for adjustments. Do not fully tighten fasteners until instructed in the assembly steps to do so (to prevent any difficulty with alignment of parts during the assembly process). When not instructed, tighten fasteners such as bolts, nuts and screws so the unit is stable, but leave room for adjustments.



Loosely Fasten

Finger tighten all hardware in this step. DO NOT wrench tighten. Some component(s) may need pre-assembly and alignment during the assembly process.



Fully Fasten

Wrench tighten all hardware in this step.

Assembly Tips

Read all "Notes" on each page before beginning each step.

While you may be able to assemble the EWC-25 using the illustrations only, IMPORTANT safety notes and other tips are included in the text.

Some pieces may have extra holes that you will not use. Use only those holes indicated in the instructions and illustration. Safety bolts (Stopper) are placed in some pieces to prevent accidental removal of moving parts, be sure to comply with the manufacturer's request.

NOTE: With so many assembled parts, proper alignment and adjustment is critical. While tightening the nuts and bolts, be sure to leave room for final adjustments.

CAUTION: Obtain assistance if you feel like you can't assemble the EWC-25 by yourself. Please do not attempt to do so as this could result in equipment failure and injuries to you. Review the installation requirements before proceeding with the assembly steps.

Maintenance Requirements

Gladiator equipment is designed to offer long-life service and minimum maintenance. Please refer to the Inspection and Schedule replacement part labels posted on the machine or on pages 3-4 of this manual. Do not use Lysol or Windex as they will dry out and crack the vinyl. Use a lanolin based hand cleaner or naugahyde cleaner on the upholstery.

Registration Card

To avoid unnecessary delays on warranty parts and to insure that a permanent record of your purchase is on file with our company, be sure to mail in the warranty registration card or register online at www.tuffstuffdirectonline.com within 10 days of purchase.

EWC-25 Step 1



Assembly List

Item #	Description	Qty.
4	BAR HOLDER	2
5	BOTTOM CROSS BRACE	1
8	REINFORCEMENT PLATE 4*50*120 (Ø11*90)	2
13	UPRIGHT FRAME LEFT SIDE	1
14	UPRIGHT FRAME RIGHT SIDE	1
15	FLAT WASHER SAE Z/P 3/8	12
18	HEX HEAD CAP SCREW Z/P 3/8-16 X 2 3/4	2
19	HEX HEAD CAP SCREW Z/P 3/8-16 X 3	4
24	NYLON INSERT LOCK NUT Z/P 3/8-16	6

NOTE:

MAKE SURE BAR HOLDERS (#4) ARE ASSEMBLED WITH THE DECALS ON THE INSIDE AS SHOWN.

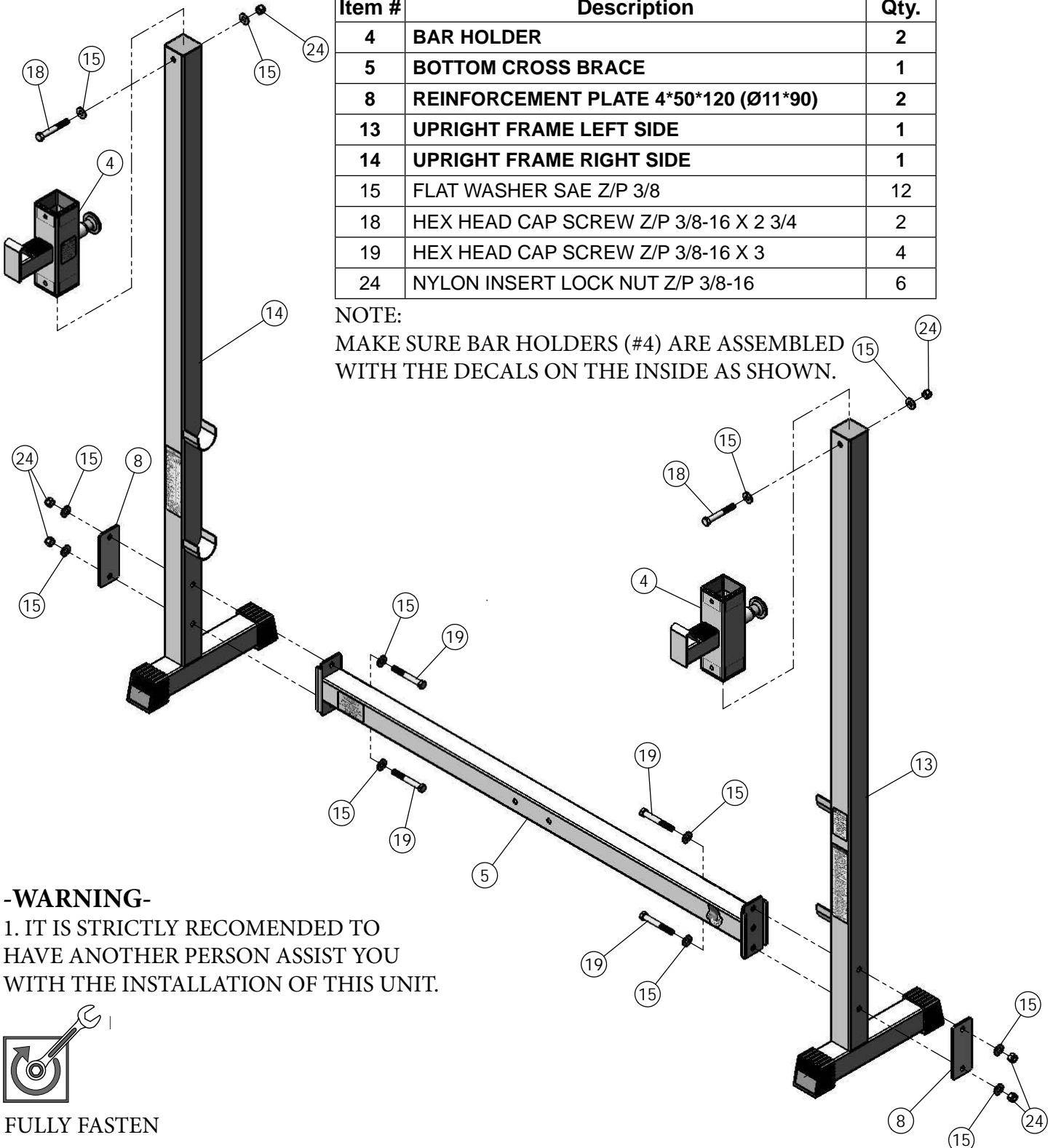

-WARNING-

1. IT IS STRICTLY RECOMENDED TO HAVE ANOTHER PERSON ASSIST YOU WITH THE INSTALLATION OF THIS UNIT.



FULLY FASTEN

EWC-25 Step 2



Assembly List

Item #	Description	Qty.
6	CARRIAGE	1
7	FRONT FRAME	1
9	SEAT FRAME	1
11	SELECTORIZED FRAME	1
12	SUPPORT BAR	1
15	FLAT WASHER SAE Z/P 3/8	7
17	HEX HEAD CAP SCREW Z/P 3/8-16 X 1/2	3
19	HEX HEAD CAP SCREW Z/P 3/8-16 X 2 7/8	2
24	NYLON INSERT LOCK NUT Z/P 3/8-16	2

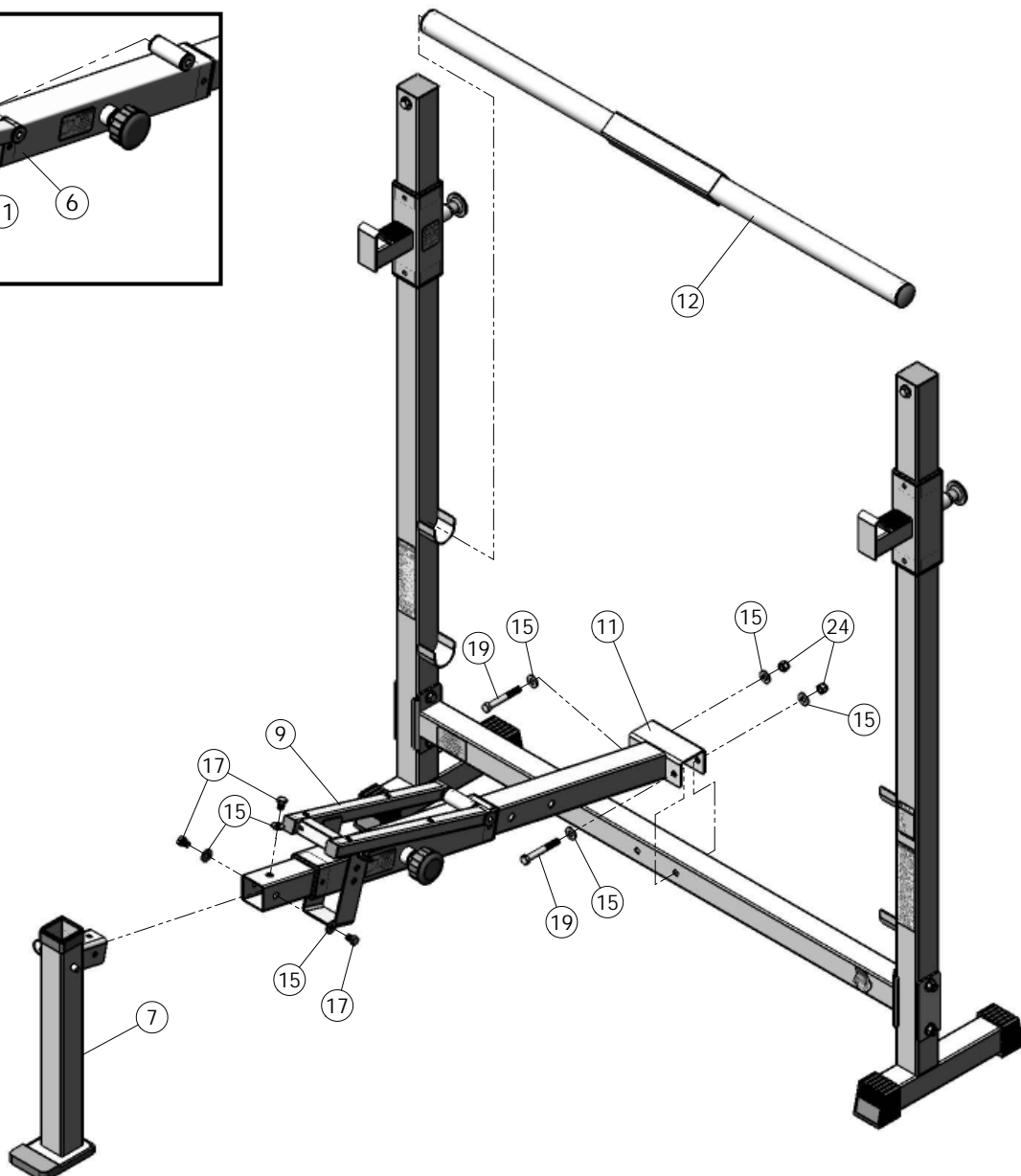
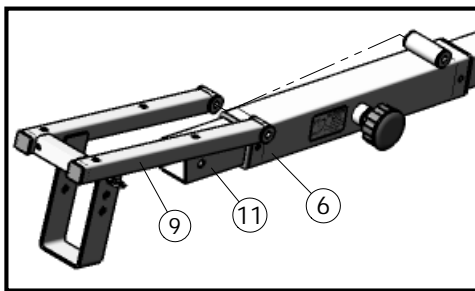

FULLY FASTEN

EWC-25 Step 3



Assembly List

Item #	Description	Qty.
2	BACK PAD	1
3	BACK PAD SUPPORT FRAME	1
10	SEAT PAD	1
15	FLAT WASHER SAE Z/P 3/8	2
16	FLAT WASHER SAE Z/P 5/16	8
20	HEX HEAD CAP SCREW Z/P 3/8-16 X 8 3/4	1
21	HEX HEAD CAP SCREW Z/P 5/16-18 X 1 3/4	8
22	LOCKING PIN Ø10mm X 105mm	1
24	NYLON INSERT LOCK NUT Z/P 3/8-16	1

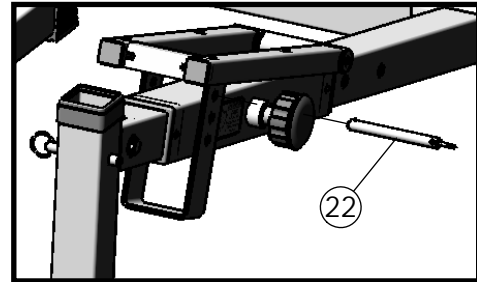

INSERT LOCKING PIN (10mm X 105mm) INTO HOLES TO ADJUST SEAT HEIGHT

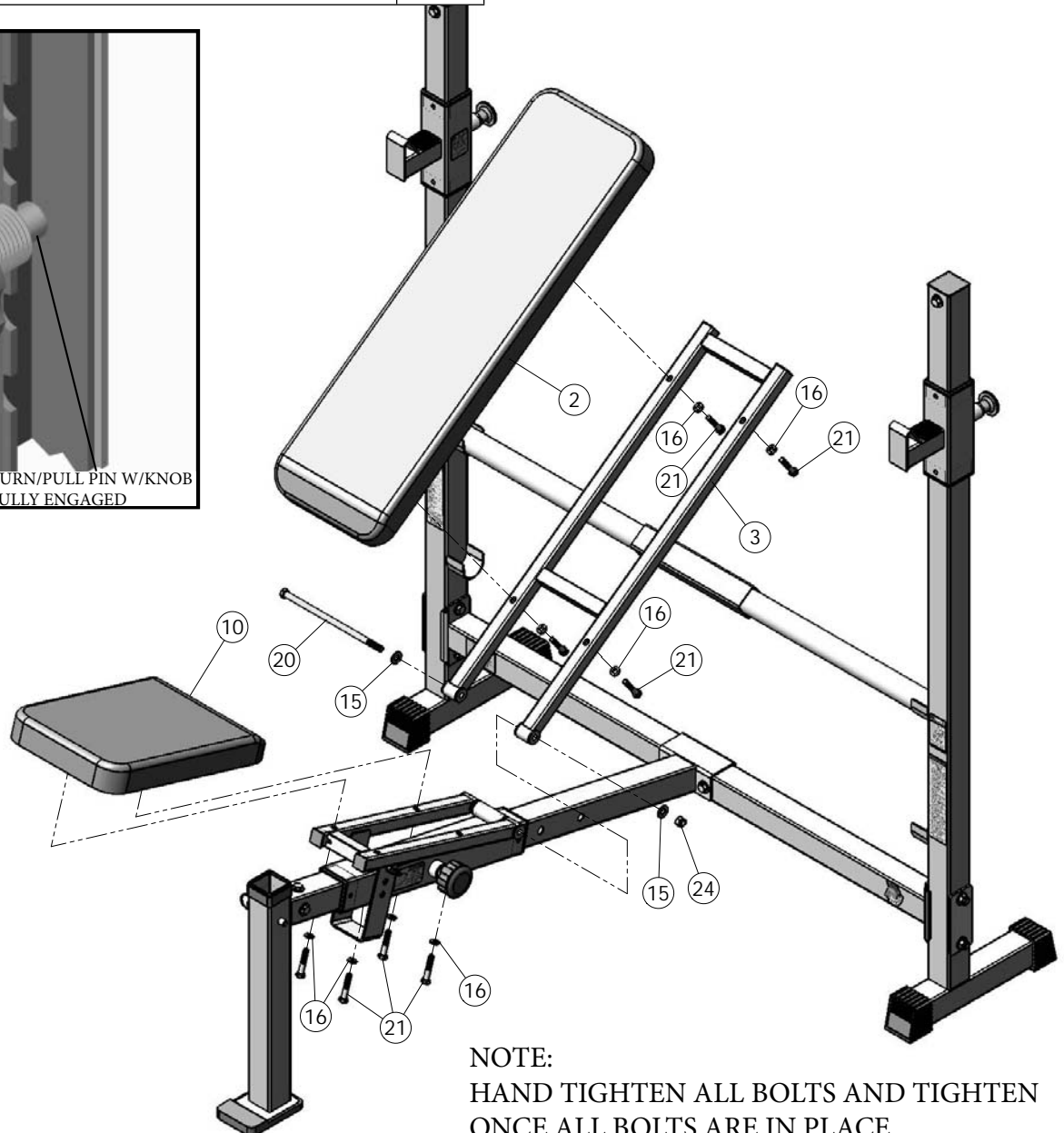
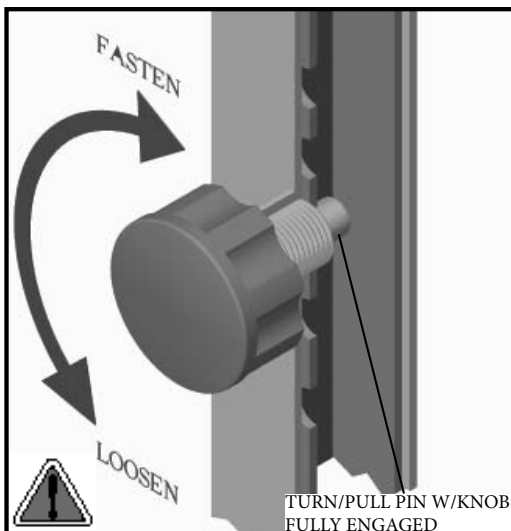

NOTE:
HAND TIGHTEN ALL BOLTS AND TIGHTEN ONCE ALL BOLTS ARE IN PLACE.



FULLY FASTEN

EWC-25 Parts List



EWC-25 Parts List

ITEM	DESCRIPTION	REV	PART NO.	QTY
1	LEG DEVELOPER ATTACHMENT		ELC-18	1
2	BACK PAD	0	GLA1049	1
3	BACK PAD SUPPORT FRAME	0	GLA1050	1
4	BAR HOLDER	0	GLA1063	2
5	BOTTOM CROSS BRACE	0	GLA1051	1
6	CARRIAGE	0	GLA1052	1
7	FRONT FRAME	0	GLA1053	1
8	REINFORCEMENT PLATE 4*50*120 (Ø11*90)	0	GLA1065	2
9	SEAT FRAME	0	GLA1054	1
10	SEAT PAD	0	GLA1055	1
11	SELECTORIZED FRAME	0	GLA1056	1
12	SUPPORT BAR	0	GLA1057	1
13	UPRIGHT FRAME LEFT SIDE	0	GLA1058	1
14	UPRIGHT FRAME RIGHT SIDE	0	GLA1059	1
15	FLAT WASHER SAE Z/P 3/8		BNH0239	21
16	FLAT WASHER SAE Z/P 5/16		BNH4136	8
17	HEX HEAD CAP SCREW Z/P 3/8-16 X 1/2		BNH4138	3
18	HEX HEAD CAP SCREW Z/P 3/8-16 X 2 3/4		BNH2045	2
19	HEX HEAD CAP SCREW Z/P 3/8-16 X 2 7/8		BNH4149	6
20	HEX HEAD CAP SCREW Z/P 3/8-16 X 8 3/4		BNH4178	1
21	HEX HEAD CAP SCREW Z/P 5/16-18 X 1 3/4		BNH4158	8
22	LOCKING PIN Ø10mm X 105mm		BNH4167	1
23	LOCKING PIN Ø10mm X 85mm		BNH4163	1
24	NYLON INSERT LOCK NUT Z/P 3/8-16		BNH4142	9
25	PLASTIC BUSHING Ø25*Ø22*Ø10*12		BNH4165	10
26	PLASTIC END CAP W/GROOVE 2" SQ		BNH4152	4
27	PLASTIC INSERT CAP 2" SQ.		BNH4144	2
28	PLASTIC INSERT CAP 25*25*2		BNH4164	4
29	PLASTIC INSERT CAP RD Ø42*2		BNH4179	2
30	PLASTIC TUBE GUIDE 2" SQ.		BNH4145	1
31	RUBBER STRIP 38*40*3		BNH4176	2
32	TURN/ PULL PIN W/ KNOB		BNH4148	1
33	PLASTIC TUBE GUIDE W/LIP 60*60 (50*50)		BNH4175	6
34	RUBBER FOOT 3 X 4 1/2		BNH0607	1
35	PULL PIN ASSY Ø12*M18*38L		BNH4174	2
36	LABEL-DANGER CHECK RETAINING NUT... 1.5X1.688		BNH2902	2
37	LABEL-DANGER USE THIS EQUIPMENT...		BNH2903	1
38	LABEL-DANGER MUST USE SPOTTERS...		BNH2905	2
39	LABEL-DANGER DO NOT REMOVE...		BNH2906	2
40	LABEL-WARNING SERIOUS INJURY OR DEATH CAN OCCUR...		BNH2907	1
41	LABEL-CAUTION CHECK PULL-PIN IS FULLY...		BNH2912	2
42	LABEL-CAUTION CHECK PULL-PIN IS FULLY...		BNH2914	1
43	LABEL-INSPECTIONS RECOMMENDED INSPECTION...		BNH2915	1
44	LABEL-IMPORTANT FOR SMOOTH PERFORMANCE...		BNH2916	1
45	LABEL-SCHEDULE REPLACEMENT PARTS...		BNH2917	1
46	LABEL-GLADIATOR BY TUFFSTUFF FITNESS		BNH2918	1
47	LABEL-GLADIATOR SERIES SERIAL #		BNH2919	1

EWC-25 Exploded View

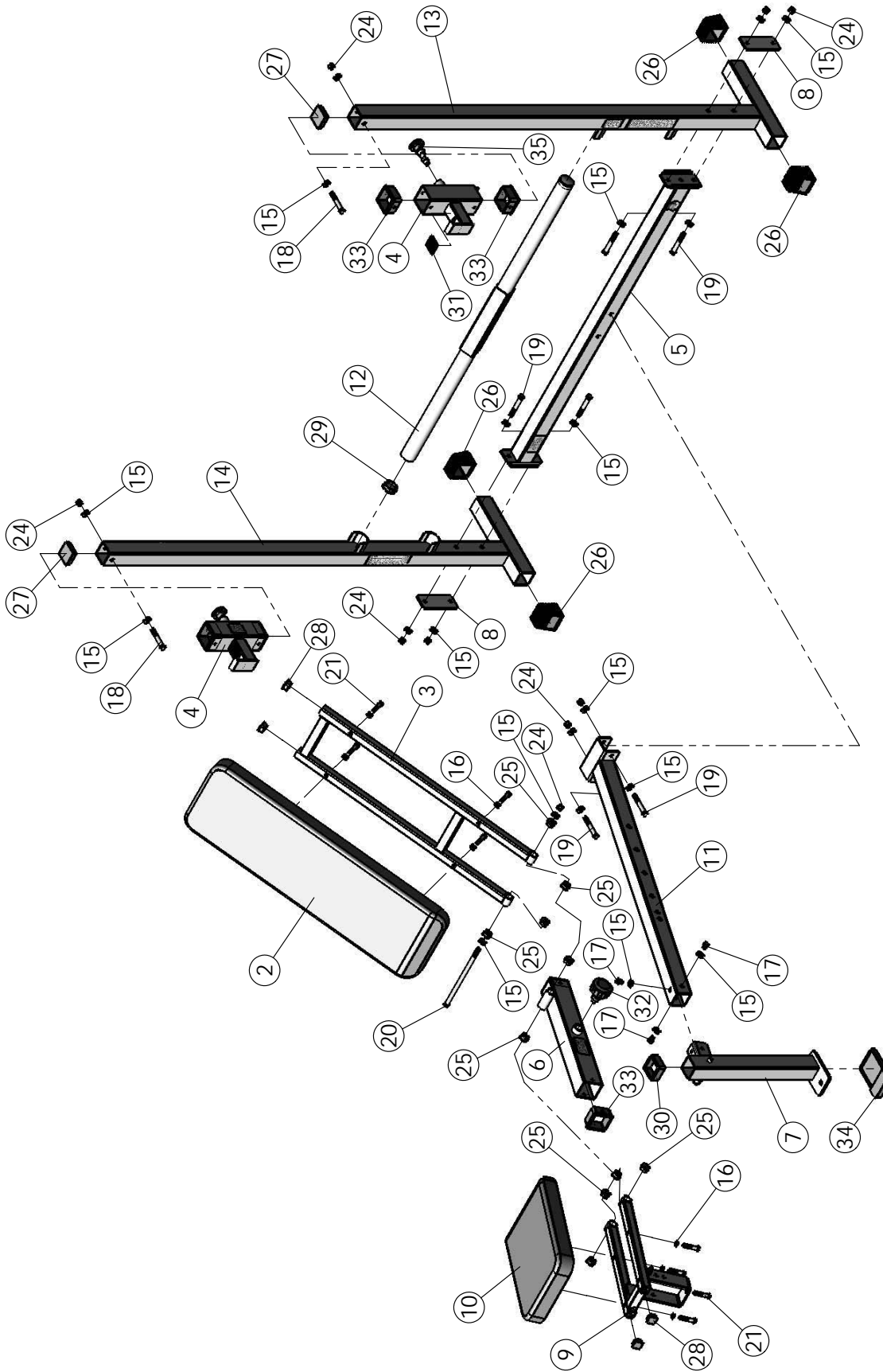

Basic Exercise Guide



Use this equipment only for the exercises as shown. Know your limitations. If you are new to weight training, always start with lighter weight, learn how to perform the exercise correctly and train at a controlled rate of speed. Warm up properly with stretchings, calisthenics or cardiovascular exercises. Never hold your breath – general rule of thumb is to exhale when you exert.

⚠ WARNING Before working out, read and understand the Owner's Manual, all danger, warning and caution labels listed on pages 3-4. This equipment is for HOME use only. Obtain a medical examination before beginning any exercise program. If you feel faint, dizzy or pain, stop exercising immediately.

FLAT PRESS



Begin/End



Mid-Range

INCLINE PRESS



Begin/End



Mid-Range

DECLINE PRESS shown with optional leg developer



Begin/End



Mid-Range

Basic Exercise Guide



Use this equipment only for the exercises as shown. Know your limitations. If you are new to weight training, always start with lighter weight, learn how to perform the exercise correctly and train at a controlled rate of speed. Warm up properly with stretchings, calisthenics or cardiovascular exercises. Never hold your breath – general rule of thumb is to exhale when you exert.

⚠ WARNING

Before working out, read and understand the Owner's Manual, all danger, warning and caution labels listed on pages 3-4. This equipment is for HOME use only. Obtain a medical examination before beginning any exercise program. If you feel faint, dizzy or pain, stop exercising immediately.

SHOULDER PRESS



Begin/End



Mid-Range

LEG EXTENSION



Begin/End



Mid-Range

PRONE LEG CURL



Begin/End



Mid-Range

Basic Exercise Guide



Use this equipment only for the exercises as shown. Know your limitations. If you are new to weight training, always start with lighter weight, learn how to perform the exercise correctly and train at a controlled rate of speed. Warm up properly with stretchings, calisthenics or cardiovascular exercises. Never hold your breath – general rule of thumb is to exhale when you exert.

⚠ WARNING Before working out, read and understand the Owner's Manual, all danger, warning and caution labels listed on pages 3-4. This equipment is for HOME use only. Obtain a medical examination before beginning any exercise program. If you feel faint, dizzy or pain, stop exercising immediately.

PREACHER ARM CURL shown with optional preacher curl attachment



Begin/End



Mid-Range

Notes



IMPORTANT: KEEP THIS MANUAL FOR FUTURE REFERENCE

WARRANTY



This warranty applies only in the United States to the products manufactured or distributed by TuffStuff Fitness Equipment Inc. under the Gladiator brand name. The warranty period to the original purchaser is 3 years on the frame and 1 year on ALL parts. TuffStuff warrants that the Product you have purchased for personal, family or household use from TuffStuff or from an authorized TuffStuff dealer is free from defects in materials or workmanship under normal use during the warranty period. This warranty extends only to you, the original purchaser and it is not transferable to anyone.

This warranty does not cover:

- A. TuffStuff products sold for and used in a commercial or institutional environment.**
- B. Any damage, failure or loss caused by accident, misuse, neglect, abuse, improper assembly, improper maintenance, or failure to follow instructions or warnings in the owner's manual and warning labels posted on the machines.**
- C. Use of the product in a manner for which it was not designed.**
- D. It excludes expendable parts such as paint and finish.**
- E. Original product that is altered, or the use of replacement parts and components of another manufacturer.**
- F. VALID ONLY if the Product is assembled and installed according to the instructions provided in the Owner's manual.**

The obligation of TuffStuff under this warranty is limited to repairing or replacing warranted defective parts as TuffStuff may elect, at TuffStuff's facility in Chino, California without charge to the purchaser. Purchaser is responsible for installation of repaired or replaced parts, and all transportation and insurance costs on returned or replaced equipment to and from TuffStuff's facility in Chino.

THE FOREGOING SHALL CONSTITUTE THE SOLE REMEDY OF THE PURCHASER AND THE SOLE LIABILITY OF TUFFSTUFF WITH REGARD TO WARRANTY, WHETHER EXPRESS OR IMPLIED BY OPERATION OF LAW OR OTHERWISE, INCLUDING BUT NOT LIMITED TO ANY IMPLIED WARRANTIES OF MERCHANTABILITY OR FITNESS. TUFFSTUFF SHALL IN NO EVENT BE LIABLE FOR INCIDENTAL OR CONSEQUENTIAL LOSSES, DAMAGES, OR EXPENSES IN CONNECTIONS WITH EXERCISE PRODUCTS. TUFFSTUFF'S LIABILITY HEREUNDER IS EXPRESSLY LIMITED TO THE REPAIRS OR REPLACEMENTS OF WARRANTED DEFECTIVE PARTS.

This written warranty is the final, complete and exclusive agreement of the parties with respect to the quality or performance of the equipment and no action for breach of this written warranty or any implied warranty shall be commenced more than one (1) year after the accrual of the cause of action. No modification of this warranty or waiver of its terms shall be binding on either party unless approved in writing by an authorized representative of the party. Contact TuffStuff Fitness Equipment Inc. at 13971 Norton Avenue, Chino, CA 91710, before returning any defective equipment.

This warranty gives you specific legal rights and you may also have other rights, which may vary from state to state.

SERIAL #

Write your Serial number here for future reference

Purchase Date

Gladiator is a brand name product manufactured and distributed by:



TuffStuff Fitness Equipment Inc.

13971 Norton Avenue, Chino, CA 91710, USA

Phone: 909-629-1600 Fax: 909-629-4967

service@tuffstuff.net service1@tuffstuff.net

www.tuffstuffdirectonline.com