



OM-4425

215 234F

July 2004

Processes



Stick (SMAW) Welding



TIG (GTAW) Welding



MIG (GMAW) Welding



Flux Cored (FCAW) Welding



Air Carbon Arc (CAC-A)
Cutting and Gouging

Description



Engine Driven Welding Generator

Big Blue[®] 400D

Big Blue[®] 500 X

(Deutz-Powered)

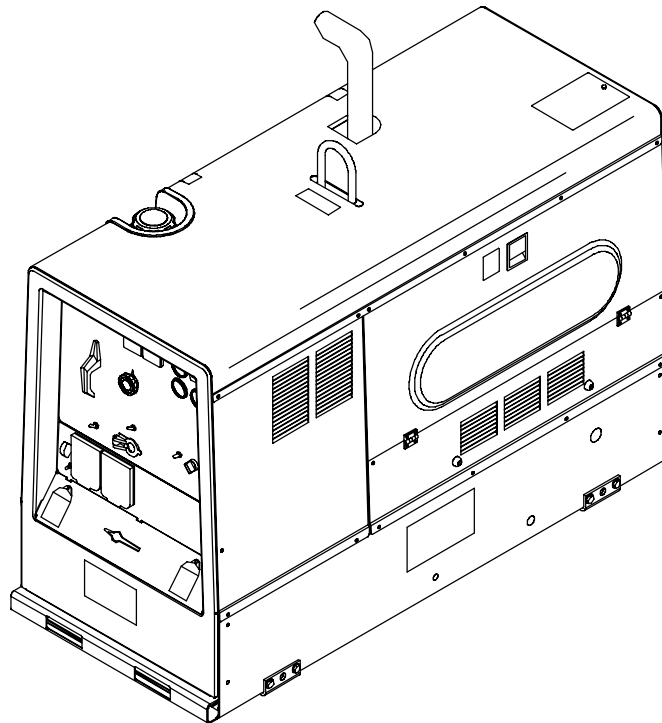

Visit our website at
www.MillerWelds.com

OWNER'S MANUAL

From Miller to You

Thank you and congratulations on choosing Miller. Now you can get the job done and get it done right. We know you don't have time to do it any other way.

That's why when Niels Miller first started building arc welders in 1929, he made sure his products offered long-lasting value and superior quality. Like you, his customers couldn't afford anything less. Miller products had to be more than the best they could be. They had to be the best you could buy.

Today, the people that build and sell Miller products continue the tradition. They're just as committed to providing equipment and service that meets the high standards of quality and value established in 1929.

This Owner's Manual is designed to help you get the most out of your Miller products. Please take time to read the Safety precautions. They will help you protect yourself against potential hazards on the worksite.

We've made installation and operation quick and easy. With Miller you can count on years of reliable service with proper maintenance. And if for some reason the unit needs repair, there's a Troubleshooting section that will help you figure out what the problem is. The parts list will then help you to decide the exact part you may need to fix the problem. Warranty and service information for your particular model are also provided.



Miller is the first welding equipment manufacturer in the U.S.A. to be registered to the ISO 9001:2000 Quality System Standard.

Miller Electric manufactures a full line of welders and welding related equipment. For information on other quality Miller products, contact your local Miller distributor to receive the latest full line catalog or individual catalog sheets. **To locate your nearest distributor or service agency call 1-800-4-A-Miller, or visit us at www.MillerWelds.com on the web.**



Working as hard as you do – every power source from Miller is backed by the most hassle-free warranty in the business.



TABLE OF CONTENTS

SECTION 1 – SAFETY PRECAUTIONS – READ BEFORE USING	1
1-1. Symbol Usage	1
1-2. Arc Welding Hazards	1
1-3. Engine Hazards	2
1-4. Compressed Air Hazards	3
1-5. Additional Symbols For Installation, Operation, And Maintenance	3
1-6. California Proposition 65 Warnings	4
1-7. Principal Safety Standards	4
1-8. EMF Information	4
SECTION 2 – CONSIGNES DE SÉCURITÉ – LIRE AVANT UTILISATION	5
2-1. Signification des symboles	5
2-2. Dangers relatifs au soudage à l'arc	5
2-3. Dangers existant en relation avec le moteur	6
2-4. Dangers liés à l'air comprimé	7
2-5. Dangers supplémentaires en relation avec l'installation, le fonctionnement et la maintenance	7
2-6. Principales normes de sécurité	8
2-7. Information sur les champs électromagnétiques	8
SECTION 3 – DEFINITIONS	9
3-1. Warning Label Definitions (CE Models Only)	9
3-2. Manufacturer's Rating Labels	13
3-3. Symbols And Definitions	14
SECTION 4 – SPECIFICATIONS	15
4-1. Weld, Power, And Engine Specifications	15
4-2. Dimensions, Weights, And Operating Angles	15
4-3. Volt-Ampere Curves For CC Models	16
4-4. Volt-Ampere Curves For CC/CV Models	17
4-5. Fuel Consumption	18
4-6. Duty Cycle And Overheating	18
4-7. AC Generator Power Curve	19
4-8. Optional Three-Phase Generator Curves	19
SECTION 5 – INSTALLATION	20
5-1. Installing Welding Generator (See Sections 5-2 And 5-3)	20
5-2. Using Lifting Eye	21
5-3. Mounting Welding Generator	22
5-4. Installing Exhaust Pipe	23
5-5. Activating The Dry Charge Battery (If Applicable)	24
5-6. Connecting The Battery	25
5-7. Engine Prestart Checks	26
5-8. Connecting To Weld Output Terminals	27
5-9. Selecting Weld Cable Sizes*	27
5-10. Connecting To Remote Amperage Adjust Receptacle RC13 On CC Models	28
5-11. Connecting To Remote 14 Receptacle RC14 On CC/CV Models	29
SECTION 6 – OPERATING WELDING GENERATOR – CC MODELS	30
6-1. Front Panel Controls For CC Models (See Section 6-2)	30
6-2. Description Of Front Panel Controls For CC Models (See Section 6-1)	31
6-3. Remote Amperage Control On CC Models (Optional)	32
6-4. Weld Control/Arc Condition Information Label	32
SECTION 7 – OPERATING WELDING GENERATOR – CC/CV MODELS	34
7-1. Front Panel Controls For CC/CV Models (See Section 7-2)	34
7-2. Description Of Front Panel Controls For CC/CV Models (See Section 7-1)	35
7-3. Process/Contactor Switch On CC/CV Models	36
7-4. Remote Voltage/Amperage Control On CC/CV Models (Optional)	37

TABLE OF CONTENTS

SECTION 8 – OPERATING AUXILIARY EQUIPMENT	38
8-1. 120 Volt And 240 Volt Receptacles	38
8-2. Connecting To Optional Three-Phase Generator (CC/CV Models Only)	39
8-3. Optional Generator Power Receptacles	40
SECTION 9 – MAINTENANCE & TROUBLESHOOTING	41
9-1. Maintenance Label	41
9-2. Routine Maintenance	42
9-3. Servicing Air Cleaner	44
9-4. Inspecting And Cleaning Optional Spark Arrestor Muffler	45
9-5. Adjusting Engine Speed	46
9-6. Servicing Fuel And Lubrication Systems	47
9-7. Overload Protection	48
9-8. Troubleshooting	49
SECTION 10 – ELECTRICAL DIAGRAMS	54
SECTION 11 – RUN-IN PROCEDURE	58
11-1. Wetstacking	58
11-2. Run-In Procedure Using Load Bank	59
11-3. Run-In Procedure Using Resistance Grid	60
SECTION 12 – GENERATOR POWER GUIDELINES	61
SECTION 13 – PARTS LIST	69
OPTIONS AND ACCESSORIES	
WARRANTY	

SECTION 1 – SAFETY PRECAUTIONS – READ BEFORE USING

rom_nd_8/03

▲ **Warning: Protect yourself and others from injury — read and follow these precautions.**

1-1. Symbol Usage



Means Warning! Watch Out! There are possible hazards with this procedure! The possible hazards are shown in the adjoining symbols.

▲ Marks a special safety message.

☞ Means “Note”; not safety related.



This group of symbols means Warning! Watch Out! possible ELECTRIC SHOCK, MOVING PARTS, and HOT PARTS hazards. Consult symbols and related instructions below for necessary actions to avoid the hazards.

1-2. Arc Welding Hazards

▲ **The symbols shown below are used throughout this manual to call attention to and identify possible hazards. When you see the symbol, watch out, and follow the related instructions to avoid the hazard. The safety information given below is only a summary of the more complete safety information found in the Safety Standards listed in Section 1-7. Read and follow all Safety Standards.**

▲ **Only qualified persons should install, operate, maintain, and repair this unit.**

▲ **During operation, keep everybody, especially children, away.**



ELECTRIC SHOCK can kill.

Touching live electrical parts can cause fatal shocks or severe burns. The electrode and work circuit is electrically live whenever the output is on. The input power circuit and machine internal circuits are also live when power is on. In semiautomatic or automatic wire welding, the wire, wire reel, drive roll housing, and all metal parts touching the welding wire are electrically live. Incorrectly installed or improperly grounded equipment is a hazard.

- Do not touch live electrical parts.
- Wear dry, hole-free insulating gloves and body protection.
- Insulate yourself from work and ground using dry insulating mats or covers big enough to prevent any physical contact with the work or ground.
- Do not use AC output in damp areas, if movement is confined, or if there is a danger of falling.
- Use AC output ONLY if required for the welding process.
- If AC output is required, use remote output control if present on unit.
- Additional safety precautions are required when any of the following electrically hazardous conditions are present: in damp locations or while wearing wet clothing; on metal structures such as floors, gratings, or scaffolds; when in cramped positions such as sitting, kneeling, or lying; or when there is a high risk of unavoidable or accidental contact with the workpiece or ground. For these conditions, use the following equipment in order presented: 1) a semiautomatic DC constant voltage (wire) welder, 2) a DC manual (stick) welder, or 3) an AC welder with reduced open-circuit voltage. In most situations, use of a DC, constant voltage wire welder is recommended. And, do not work alone!
- Disconnect input power or stop engine before installing or servicing this equipment. Lockout/tagout input power according to OSHA 29 CFR 1910.147 (see Safety Standards).
- Properly install and ground this equipment according to its Owner's Manual and national, state, and local codes.
- Always verify the supply ground — check and be sure that input power cord ground wire is properly connected to ground terminal in disconnect box or that cord plug is connected to a properly grounded receptacle outlet.
- When making input connections, attach proper grounding conductor first — double-check connections.
- Frequently inspect input power cord for damage or bare wiring — replace cord immediately if damaged — bare wiring can kill.
- Turn off all equipment when not in use.
- Do not use worn, damaged, undersized, or poorly spliced cables.
- Do not drape cables over your body.
- If earth grounding of the workpiece is required, ground it directly with a separate cable.
- Do not touch electrode if you are in contact with the work, ground, or another electrode from a different machine.

- Use only well-maintained equipment. Repair or replace damaged parts at once. Maintain unit according to manual.
- Wear a safety harness if working above floor level.
- Keep all panels and covers securely in place.
- Clamp work cable with good metal-to-metal contact to workpiece or worktable as near the weld as practical.
- Insulate work clamp when not connected to workpiece to prevent contact with any metal object.
- Do not connect more than one electrode or work cable to any single weld output terminal.

SIGNIFICANT DC VOLTAGE exists in inverters after stopping engine.

- Stop engine on inverter and discharge input capacitors according to instructions in Maintenance Section before touching any parts.



FUMES AND GASES can be hazardous.

Welding produces fumes and gases. Breathing these fumes and gases can be hazardous to your health.

- Keep your head out of the fumes. Do not breathe the fumes.
- If inside, ventilate the area and/or use exhaust at the arc to remove welding fumes and gases.
- If ventilation is poor, use an approved air-supplied respirator.
- Read the Material Safety Data Sheets (MSDSs) and the manufacturer's instructions for metals, consumables, coatings, cleaners, and degreasers.
- Work in a confined space only if it is well ventilated, or while wearing an air-supplied respirator. Always have a trained watchperson nearby. Welding fumes and gases can displace air and lower the oxygen level causing injury or death. Be sure the breathing air is safe.
- Do not weld in locations near degreasing, cleaning, or spraying operations. The heat and rays of the arc can react with vapors to form highly toxic and irritating gases.
- Do not weld on coated metals, such as galvanized, lead, or cadmium plated steel, unless the coating is removed from the weld area, the area is well ventilated, and if necessary, while wearing an air-supplied respirator. The coatings and any metals containing these elements can give off toxic fumes if welded.



BUILDUP OF GAS can injure or kill.

- Shut off shielding gas supply when not in use.
- Always ventilate confined spaces or use approved air-supplied respirator.

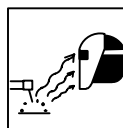

ARC RAYS can burn eyes and skin.

Arc rays from the welding process produce intense visible and invisible (ultraviolet and infrared) rays that can burn eyes and skin. Sparks fly off from the weld.

- Wear a welding helmet fitted with a proper shade of filter to protect your face and eyes from arc rays and sparks when welding or watching (see ANSI Z49.1 and Z87.1 listed in Safety Standards).
- Wear approved safety glasses with side shields under your helmet.
- Use protective screens or barriers to protect others from flash and glare; warn others not to watch the arc.
- Wear protective clothing made from durable, flame-resistant material (wool and leather) and foot protection.



WELDING can cause fire or explosion.

Welding on closed containers, such as tanks, drums, or pipes, can cause them to blow up. Sparks can fly off from the welding arc. The flying sparks, hot workpiece, and hot equipment can cause fires and burns. Accidental contact of electrode to metal objects can cause sparks, explosion, overheating, or fire. Check and be sure the area is safe before doing any welding.

- Protect yourself and others from flying sparks and hot metal.
- Do not weld where flying sparks can strike flammable material.
- Remove all flammables within 35 ft (10.7 m) of the welding arc. If this is not possible, tightly cover them with approved covers.
- Be alert that welding sparks and hot materials from welding can easily go through small cracks and openings to adjacent areas.
- Watch for fire, and keep a fire extinguisher nearby.
- Be aware that welding on a ceiling, floor, bulkhead, or partition can cause fire on the hidden side.
- Do not weld on closed containers such as tanks, drums, or pipes, unless they are properly prepared according to AWS F4.1 (see Safety Standards).
- Connect work cable to the work as close to the welding area as practical to prevent welding current from traveling long, possibly unknown paths and causing electric shock and fire hazards.
- Do not use welder to thaw frozen pipes.
- Remove stick electrode from holder or cut off welding wire at contact tip when not in use.
- Wear oil-free protective garments such as leather gloves, heavy shirt, cuffless trousers, high shoes, and a cap.
- Remove any combustibles, such as a butane lighter or matches, from your person before doing any welding.
- Follow requirements in OSHA 1910.252 (a) (2) (iv) and NFPA 51B for hot work and have a fire watcher and extinguisher nearby.

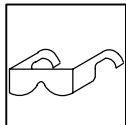

FLYING METAL can injure eyes.

- Welding, chipping, wire brushing, and grinding cause sparks and flying metal. As welds cool, they can throw off slag.
- Wear approved safety glasses with side shields even under your welding helmet.



HOT PARTS can cause severe burns.

- Allow cooling period before maintaining.
- Wear protective gloves and clothing when working on a hot engine.
- Do not touch hot engine parts or just-welded parts bare-handed.



NOISE can damage hearing.

Noise from some processes or equipment can damage hearing.

- Wear approved ear protection if noise level is high.



MAGNETIC FIELDS can affect pacemakers.

- Pacemaker wearers keep away.
- Wearers should consult their doctor before going near arc welding, gouging, or spot welding operations.

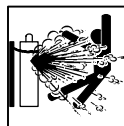

CYLINDERS can explode if damaged.

Shielding gas cylinders contain gas under high pressure. If damaged, a cylinder can explode. Since gas cylinders are normally part of the welding process, be sure to treat them carefully.

- Protect compressed gas cylinders from excessive heat, mechanical shocks, slag, open flames, sparks, and arcs.
- Install cylinders in an upright position by securing to a stationary support or cylinder rack to prevent falling or tipping.
- Keep cylinders away from any welding or other electrical circuits.
- Never drape a welding torch over a gas cylinder.
- Never allow a welding electrode to touch any cylinder.
- Never weld on a pressurized cylinder — explosion will result.
- Use only correct shielding gas cylinders, regulators, hoses, and fittings designed for the specific application; maintain them and associated parts in good condition.
- Turn face away from valve outlet when opening cylinder valve.
- Keep protective cap in place over valve except when cylinder is in use or connected for use.
- Read and follow instructions on compressed gas cylinders, associated equipment, and CGA publication P-1 listed in Safety Standards.

1-3. Engine Hazards



BATTERY EXPLOSION can BLIND.

- Always wear a face shield, rubber gloves, and protective clothing when working on a battery.
- Stop engine before disconnecting or connecting battery cables or servicing battery.
- Do not allow tools to cause sparks when working on a battery.
- Do not use welder to charge batteries or jump start vehicles.
- Observe correct polarity (+ and -) on batteries.
- Disconnect negative (-) cable first and connect it last.



FUEL can cause fire or explosion.

- Stop engine and let it cool off before checking or adding fuel.
- Do not add fuel while smoking or if unit is near any sparks or open flames.
- Do not overfill tank — allow room for fuel to expand.
- Do not spill fuel. If fuel is spilled, clean up before starting engine.
- Dispose of rags in a fireproof container.
- Always keep nozzle in contact with tank when fueling.



MOVING PARTS can cause injury.

- Keep away from fans, belts, and rotors.
- Keep all doors, panels, covers, and guards closed and securely in place.
- Stop engine before installing or connecting unit.
- Have only qualified people remove guards or covers for maintenance and troubleshooting as necessary.
- To prevent accidental starting during servicing, disconnect negative (-) battery cable from battery.
- Keep hands, hair, loose clothing, and tools away from moving parts.
- Reinstall panels or guards and close doors when servicing is finished and before starting engine.
- Before working on generator, remove spark plugs or injectors to keep engine from kicking back or starting.
- Block flywheel so that it will not turn while working on generator components.



STEAM AND HOT COOLANT can burn.

- If possible, check coolant level when engine is cold to avoid scalding.
- Always check coolant level at overflow tank, if present on unit, instead of radiator (unless told otherwise in maintenance section or engine manual).
- If the engine is warm, checking is needed, and there is no overflow tank, follow the next two statements.
- Wear safety glasses and gloves and put a rag over radiator cap.
- Turn cap slightly and let pressure escape slowly before completely removing cap.



ENGINE EXHAUST GASES can kill.

- Use equipment outside in open, well-ventilated areas.
- If used in a closed area, vent engine exhaust outside and away from any building air intakes.

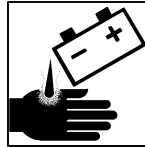

BATTERY ACID can BURN SKIN and EYES.

- Do not tip battery.
- Replace damaged battery.
- Flush eyes and skin immediately with water.



ENGINE HEAT can cause fire.

- Do not locate unit on, over, or near combustible surfaces or flammables.
- Keep exhaust and exhaust pipes way from flammables.



EXHAUST SPARKS can cause fire.

- Do not let engine exhaust sparks cause fire.
- Use approved engine exhaust spark arrestor in required areas — see applicable codes.

1-4. Compressed Air Hazards



BREATHING COMPRESSED AIR can cause serious injury or death.

- Do not use compressed air for breathing.
- Use only for cutting, gouging, and tools.

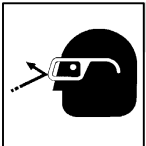

COMPRESSED AIR can cause injury.

- Wear approved safety goggles.
- Do not direct air stream toward self or others.



TRAPPED AIR PRESSURE AND WHIPPING HOSES can cause injury.

- Release air pressure from tools and system before servicing, adding or changing attachments, or opening compressor oil drain or oil fill cap.



HOT METAL from air arc cutting and gouging can cause fire or explosion.

- Do not cut or gouge near flammables.
- Watch for fire; keep extinguisher nearby.



HOT PARTS can cause burns and injury.

- Do not touch hot compressor or air system parts.
- Let system cool down before touching or servicing.

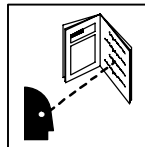

READ INSTRUCTIONS.

- Read Owner's Manual before using or servicing unit.
- Stop engine and release air pressure before servicing.

1-5. Additional Symbols For Installation, Operation, And Maintenance



FALLING UNIT can cause injury.

- Use lifting eye to lift unit only, NOT running gear, gas cylinders, trailer, or any other accessories.
- Use equipment of adequate capacity to lift and support unit.
- If using lift forks to move unit, be sure forks are long enough to extend beyond opposite side of unit.

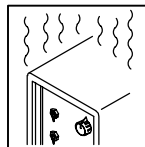

OVERUSE can cause OVERHEATING.

- Allow cooling period; follow rated duty cycle.
- Reduce current or reduce duty cycle before starting to weld again.
- Do not block or filter airflow to unit.

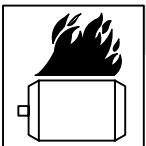

OVERHEATING can damage motors.

- Turn off or unplug equipment before starting or stopping engine.
- Do not let low voltage and frequency caused by low engine speed damage electric motors.
- Do not connect 50 or 60 Hertz motors to the 100 Hertz receptacle where applicable.

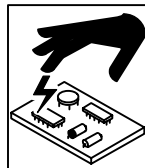

STATIC (ESD) can damage PC boards.

- Put on grounded wrist strap BEFORE handling boards or parts.
- Use proper static-proof bags and boxes to store, move, or ship PC boards.

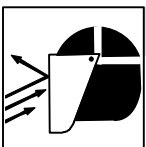

FLYING SPARKS can cause injury.

- Wear a face shield to protect eyes and face.
- Shape tungsten electrode only on grinder with proper guards in a safe location wearing proper face, hand, and body protection.
- Sparks can cause fires — keep flammables away.



TILTING OF TRAILER can cause injury.

- Use tongue jack or blocks to support weight.
- Properly install welding generator onto trailer according to instructions supplied with trailer.

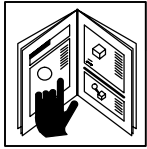

READ INSTRUCTIONS.

- Use only genuine MILLER/Hobart replacement parts.
- Perform engine and air compressor (if applicable) maintenance and service according to this manual and the engine/air compressor (if applicable) manuals.

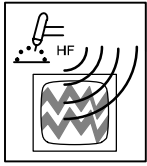

H.F. RADIATION can cause interference.

- High-frequency (H.F.) can interfere with radio navigation, safety services, computers, and communications equipment.
- Have only qualified persons familiar with electronic equipment perform this installation.
- The user is responsible for having a qualified electrician promptly correct any interference problem resulting from the installation.
- If notified by the FCC about interference, stop using the equipment at once.
- Have the installation regularly checked and maintained.
- Keep high-frequency source doors and panels tightly shut, keep spark gaps at correct setting, and use grounding and shielding to minimize the possibility of interference.

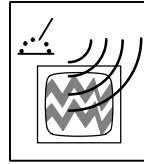

ARC WELDING can cause interference.

- Electromagnetic energy can interfere with sensitive electronic equipment such as microprocessors, computers, and computer-driven equipment such as robots.
- Be sure all equipment in the welding area is electromagnetically compatible.
- To reduce possible interference, keep weld cables as short as possible, close together, and down low, such as on the floor.
- Locate welding operation 100 meters from any sensitive electronic equipment.
- Be sure this welding machine is installed and grounded according to this manual.
- If interference still occurs, the user must take extra measures such as moving the welding machine, using shielded cables, using line filters, or shielding the work area.

1-6. California Proposition 65 Warnings

- ▲ **Welding or cutting equipment produces fumes or gases which contain chemicals known to the State of California to cause birth defects and, in some cases, cancer. (California Health & Safety Code Section 25249.5 et seq.)**
- ▲ **Battery posts, terminals and related accessories contain lead and lead compounds, chemicals known to the State of California to cause cancer and birth defects or other reproductive harm. Wash hands after handling.**

For Gasoline Engines:

- ▲ **Engine exhaust contains chemicals known to the State of California to cause cancer, birth defects, or other reproductive harm.**

For Diesel Engines:

- ▲ **Diesel engine exhaust and some of its constituents are known to the State of California to cause cancer, birth defects, and other reproductive harm.**

1-7. Principal Safety Standards

Safety in Welding, Cutting, and Allied Processes, ANSI Standard Z49.1, from American Welding Society, 550 N.W. LeJeune Rd, Miami FL 33126 (phone: 305-443-9353, website: www.aws.org).

Recommended Safe Practices for the Preparation for Welding and Cutting of Containers and Piping, American Welding Society Standard AWS F4.1, from American Welding Society, 550 N.W. LeJeune Rd, Miami, FL 33126 (phone: 305-443-9353, website: www.aws.org).

National Electrical Code, NFPA Standard 70, from National Fire Protection Association, P.O. Box 9101, 1 Battery March Park, Quincy, MA 02269-9101 (phone: 617-770-3000, website: www.nfpa.org and www.sparky.org).

Safe Handling of Compressed Gases in Cylinders, CGA Pamphlet P-1, from Compressed Gas Association, 1735 Jefferson Davis Highway, Suite 1004, Arlington, VA 22202-4102 (phone: 703-412-0900, website: www.cganet.com).

Code for Safety in Welding and Cutting, CSA Standard W117.2, from Canadian Standards Association, Standards Sales, 178 Rexdale Bou-

levard, Rexdale, Ontario, Canada M9W 1R3 (phone: 800-463-6727 or in Toronto 416-747-4044, website: www.csa-international.org).

Practice For Occupational And Educational Eye And Face Protection, ANSI Standard Z87.1, from American National Standards Institute, 11 West 42nd Street, New York, NY 10036-8002 (phone: 212-642-4900, website: www.ansi.org).

Standard for Fire Prevention During Welding, Cutting, and Other Hot Work, NFPA Standard 51B, from National Fire Protection Association, P.O. Box 9101, 1 Battery March Park, Quincy, MA 02269-9101 (phone: 617-770-3000, website: www.nfpa.org and www.sparky.org).

OSHA, Occupational Safety and Health Standards for General Industry, Title 29, Code of Federal Regulations (CFR), Part 1910, Subpart Q, and Part 1926, Subpart J, from U.S. Government Printing Office, Superintendent of Documents, P.O. Box 371954, Pittsburgh, PA 15250 (there are 10 Regional Offices—phone for Region 5, Chicago, is 312-353-2220, website: www.osha.gov).

1-8. EMF Information

Considerations About Welding And The Effects Of Low Frequency Electric And Magnetic Fields

Welding current, as it flows through welding cables, will cause electromagnetic fields. There has been and still is some concern about such fields. However, after examining more than 500 studies spanning 17 years of research, a special blue ribbon committee of the National Research Council concluded that: "The body of evidence, in the committee's judgment, has not demonstrated that exposure to power-frequency electric and magnetic fields is a human-health hazard." However, studies are still going forth and evidence continues to be examined. Until the final conclusions of the research are reached, you may wish to minimize your exposure to electromagnetic fields when welding or cutting.

To reduce magnetic fields in the workplace, use the following procedures:

1. Keep cables close together by twisting or taping them.
2. Arrange cables to one side and away from the operator.
3. Do not coil or drape cables around your body.
4. Keep welding power source and cables as far away from operator as practical.
5. Connect work clamp to workpiece as close to the weld as possible.

About Pacemakers:

Pacemaker wearers consult your doctor first. If cleared by your doctor, then following the above procedures is recommended.

SECTION 2 – CONSIGNES DE SÉCURITÉ – LIRE AVANT UTILISATION

rom_fre 8/03

▲ Avertissement: Protégez vous et les autres des blessures – lisez et suivez ces précautions.

2-1. Signification des symboles



Signifie Mise en garde ! Soyez vigilant ! Cette procédure présente des risques de danger ! Ceux-ci sont identifiés par des symboles adjacents aux directives.

▲ Identifie un message de sécurité particulier.

Signifie NOTA ; n'est pas relatif à la sécurité.



Ce groupe de symboles signifie Mise en garde ! Soyez vigilant ! Il y a des risques de danger reliés

aux CHOCS ÉLECTRIQUES, aux PIÈCES EN MOUVEMENT et aux PIÈCES CHAUDES. Reportez-vous aux symboles et aux directives ci-dessous afin de connaître les mesures à prendre pour éviter tout danger.

2-2. Dangers relatifs au soudage à l'arc

▲ Les symboles présentés ci-après sont utilisés tout au long du présent manuel pour attirer votre attention et identifier les risques de danger. Lorsque vous voyez un symbole, soyez vigilant et suivez les directives mentionnées afin d'éviter tout danger. Les consignes de sécurité présentées ci-après ne font que résumer l'information contenue dans les normes de sécurité énumérées à la section 2-6. Veuillez lire et respecter toutes ces normes de sécurité.

▲ L'installation, l'utilisation, l'entretien et les réparations ne doivent être confiés qu'à des personnes qualifiées.

▲ Au cours de l'utilisation, tenir toute personne à l'écart et plus particulièrement les enfants.



UN CHOC ÉLECTRIQUE peut tuer.

Un simple contact avec des pièces électriques peut provoquer une électrocution ou des blessures graves. L'électrode et le circuit de soudage sont sous tension dès que l'appareil est sur ON. Le circuit d'entrée et les circuits internes de l'appareil sont également sous tension à ce moment-là. En soudage semi-automatique ou automatique, le fil, le dévidoir, le logement des galets d'entraînement et les pièces métalliques en contact avec le fil de soudage sont sous tension. Des matériels mal installés ou mal mis à la terre présentent un danger.

- Ne jamais toucher les pièces électriques sous tension.
- Porter des gants et des vêtements de protection secs ne comportant pas de trous.
- S'isoler de la pièce et de la terre au moyen de tapis ou d'autres moyens isolants suffisamment grands pour empêcher le contact physique éventuel avec la pièce ou la terre.
- Ne pas se servir de source électrique à courant électrique dans les zones humides, dans des endroits confinés ou là où on risque de tomber.
- Se servir d'une source électrique à courant électrique UNIQUEMENT si le procédé de soudage le demande.
- Si l'utilisation d'une source électrique à courant électrique s'avère nécessaire, se servir de la fonction de télécommande si l'appareil en est équipé.
- Des précautions de sécurité supplémentaires sont requises dans des environnements à risque comme: les endroits humides ou lorsque l'on porte des vêtements mouillés; sur des structures métalliques au sol, grillages et échafaudages; dans des positions assises, à genoux et allongées; ou quand il y a un risque important de contact accidentel avec la pièce ou le sol. Dans ces cas utiliser les appareils suivants dans l'ordre de préférence: 1) un poste à souder DC semi-automatique de type CV (MIG/MAG), 2) un poste à souder manuel (électrode enrobée) DC, 3) un poste à souder manuel AC avec tension à vide réduite. Dans la plupart des cas, un poste courant continu de type CV est recommandé. Et, ne pas travailler seul!
- Couper l'alimentation ou arrêter le moteur avant de procéder à l'installation, à la réparation ou à l'entretien de l'appareil. Déverrouiller l'alimentation selon la norme OSHA 29 CFR 1910.147 (voir normes de sécurité).
- Installer et mettre à la terre correctement cet appareil conformément à son manuel d'utilisation et aux codes nationaux, provinciaux et municipaux.
- Toujours vérifier la terre du cordon d'alimentation – Vérifier et s'assurer que le fil de terre du cordon d'alimentation est bien raccordé à la borne de terre du sectionneur ou que la fiche du cordon est raccordée à une prise correctement mise à la terre.

- En effectuant les raccordements d'entrée fixer d'abord le conducteur de mise à la terre approprié et contre-vérifier les connexions.
- Vérifier fréquemment le cordon d'alimentation pour voir s'il n'est pas endommagé ou dénudé – remplacer le cordon immédiatement s'il est endommagé – un câble dénudé peut provoquer une électrocution.
- Mettre l'appareil hors tension quand on ne l'utilise pas.
- Ne pas utiliser des câbles usés, endommagés, de grosseur insuffisante ou mal épissés.
- Ne pas enrouler les câbles autour du corps.
- Si la pièce soudée doit être mise à la terre, le faire directement avec un câble distinct – ne pas utiliser le connecteur de pièce ou le câble de retour.
- Ne pas toucher l'électrode quand on est en contact avec la pièce, la terre ou une électrode provenant d'une autre machine.
- N'utiliser qu'un matériel en bon état. Réparer ou remplacer sur-le-champ les pièces endommagées. Entretien l'appareil conformément à ce manuel.
- Porter un harnais de sécurité quand on travaille en hauteur.
- Maintenir solidement en place tous les panneaux et capots.
- Fixer le câble de retour de façon à obtenir un bon contact métal-métal avec la pièce à souder ou la table de travail, le plus près possible de la soudure.
- Isoler la pince de masse quand pas mis à la pièce pour éviter le contact avec tout objet métallique.

Une tension DC importante subsiste à l'intérieur des onduleurs après avoir coupé l'alimentation.

- Couper l'alimentation du poste et décharger les condensateurs d'entrée comme indiqué dans la Section Maintenance avant de toucher des composants.

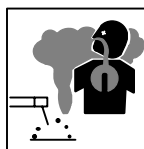

LES FUMÉES ET LES GAZ peuvent être dangereux.

Le soudage génère des fumées et des gaz. Leur inhalation peut être dangereuse pour votre santé.

- Eloigner votre tête des fumées. Ne pas respirer les fumées.
- À l'intérieur, ventiler la zone et/ou utiliser un échappement au niveau de l'arc pour l'évacuation des fumées et des gaz de soudage.
- Si la ventilation est insuffisante, utiliser un respirateur à alimentation d'air homologué.
- Lire les spécifications de sécurité des matériaux (MSDSs) et les instructions du fabricant concernant les métaux, les consommables, les revêtements, les nettoyeurs et les dégraisseurs.
- Travailler dans un espace fermé seulement s'il est bien ventilé ou en portant un respirateur à alimentation d'air. Demander toujours à un surveillant dûment formé de se tenir à proximité. Des fumées et des gaz de soudage peuvent déplacer l'air et abaisser le niveau d'oxygène provoquant des blessures ou des accidents mortels. S'assurer que l'air de respiration ne présente aucun danger.
- Ne pas souder dans des endroits situés à proximité d'opérations de dégraissage, de nettoyage ou de pulvérisation. La chaleur et les rayons de l'arc peuvent réagir en présence de vapeurs et former des gaz hautement toxiques et irritants.
- Ne pas souder des métaux munis d'un revêtement, tels que l'acier galvanisé, plaqué en plomb ou au cadmium à moins que le revêtement n'ait été enlevé dans la zone de soudure, que l'endroit soit bien ventilé, et si nécessaire, en portant un respirateur à alimentation d'air. Les revêtements et tous les métaux renfermant ces éléments peuvent dégager des fumées toxiques en cas de soudage.



LES ACCUMULATIONS DE GAZ risquent de provoquer des blessures ou même la mort.

- Fermer l'alimentation du gaz protecteur en cas de non utilisation.
- Veiller toujours à bien aérer les espaces confinés ou se servir d'un respirateur d'adduction d'air homologué.

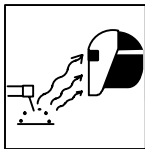

LES RAYONS DE L'ARC peuvent provoquer des brûlures dans les yeux et sur la peau.

Le rayonnement de l'arc du procédé de soudage génère des rayons visibles et invisibles intenses (ultraviolets et infrarouges) susceptibles de provoquer des brûlures dans les yeux et sur la peau. Des étincelles sont projetées pendant le soudage.

- Porter un casque de soudage muni d'un écran de filtre approprié pour protéger votre visage et vos yeux pendant le soudage ou pour regarder (voir ANSI Z49.1 et Z87.1 énuméré dans les normes de sécurité).
- Porter des protections approuvés pour les oreilles si le niveau sonore est trop élevé.
- Utiliser des écrans ou des barrières pour protéger des tiers de l'éclair et de l'éblouissement; demander aux autres personnes de ne pas regarder l'arc.
- Porter des vêtements de protection constitué dans une matière durable, résistant au feu (laine ou cuir) et une protection des pieds.



LE SOUDAGE peut provoquer un incendie ou une explosion.

Le soudage effectué sur des conteneurs fermés tels que des réservoirs, tambours ou des conduites peut provoquer leur éclatement. Des étincelles peuvent être projetées de l'arc de soudure. La projection d'étincelles, des pièces chaudes et des équipements chauds peut provoquer des incendies et des brûlures. Le contact accidentel de l'électrode avec des objets métalliques peut provoquer des étincelles, une explosion, un surchauffement ou un incendie. Avant de commencer le soudage, vérifier et s'assurer que l'endroit ne présente pas de danger.

- Se protéger et d'autres personnes de la projection d'étincelles et de métal chaud.
- Ne pas souder dans un endroit là où des étincelles peuvent tomber sur des substances inflammables.
- Déplacer toutes les substances inflammables à une distance de 10,7 m de l'arc de soudage. En cas d'impossibilité les recouvrir soigneusement avec des protections homologués.
- Des étincelles et des matériaux chauds du soudage peuvent facilement passer dans d'autres zones en traversant de petites fissures et des ouvertures.
- Surveiller tout déclenchement d'incendie et tenir un extincteur à proximité.
- Le soudage effectué sur un plafond, plancher, paroi ou séparation peut déclencher un incendie de l'autre côté.
- Ne pas effectuer le soudage sur des conteneurs fermés tels que des réservoirs, tambours, ou conduites, à moins qu'ils n'aient été préparés correctement conformément à AWS F4.1 (voir les normes de sécurité).
- Brancher le câble sur la pièce le plus près possible de la zone de soudage pour éviter le transport du courant sur une longue distance par des chemins inconnus éventuels en provoquant des risques d'électrocution et d'incendie.
- Ne pas utiliser le poste de soudage pour dégeler des conduites gelées.
- En cas de non utilisation, enlever la baguette d'électrode du porte-électrode ou couper le fil à la pointe de contact.
- Porter des vêtements de protection dépourvus d'huile tels que des gants en cuir, une chemise en matériau lourd, des pantalons sans revers, des chaussures hautes et un couvre chef.
- Avant de souder, retirer toute substance combustible de vos poches telles qu'un allumeur au butane ou des allumettes.

2-3. Dangers existant en relation avec le moteur



LES ACCUMULATIONS DE GAZ risquent de provoquer des blessures ou même la mort.

- Fermer l'alimentation du gaz protecteur en cas de non utilisation.
- Veiller toujours à bien aérer les espaces confinés ou se servir d'un respirateur d'adduction d'air homologué.

- Suivre les recommandations dans OSHA 1910.252(a)(2)(iv) et NFPA 51B pour les travaux à chaud et avoir de la surveillance et un extincteur à proximité.

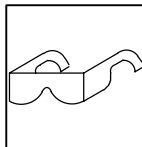

DES PARTICULES VOLANTES peuvent blesser les yeux.

- Le soudage, l'écaillage, le passage de la pièce à la brosse en fil de fer, et le meulage génèrent des étincelles et des particules métalliques volantes. Pendant la période de refroidissement des soudures, elles risquent de projeter du laitier.

- Porter des lunettes de sécurité avec écrans latéraux ou un écran facial.



DES PIÈCES CHAUDES peuvent provoquer des brûlures graves.

- Prévoir une période de refroidissement avant d'effectuer des travaux d'entretien.
- Porter des gants et des vêtements de protection pour travailler sur un moteur chaud.
- Ne pas toucher à mains nues les parties chaudes du moteur ni les pièces récemment soudées.

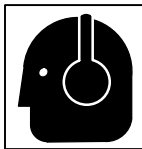

LE BRUIT peut affecter l'ouïe.

Le bruit des processus et des équipements peut affecter l'ouïe.

- Porter des protections approuvés pour les oreilles si le niveau sonore est trop élevé.

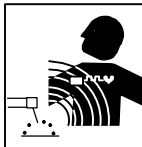

LES CHAMPS MAGNÉTIQUES peuvent affecter les stimulateurs cardiaques.

- Porteurs de stimulateur cardiaque, restez à distance.
- Les porteurs d'un stimulateur cardiaque doivent d'abord consulter leur médecin avant de s'approcher des opérations de soudage à l'arc, de gougeage ou de soudage par points.

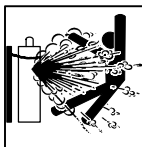

Si des BOUTEILLES sont endommagées, elles pourront exploser.

Des bouteilles de gaz protecteur contiennent du gaz sous haute pression. Si une bouteille est endommagée, elle peut exploser. Du fait que les bouteilles de gaz font normalement partie du procédé de soudage, les manipuler avec précaution.

- Protéger les bouteilles de gaz comprimé d'une chaleur excessive, des chocs mécaniques, du laitier, des flammes ouvertes, des étincelles et des arcs.
- Placer les bouteilles debout en les fixant dans un support stationnaire ou dans un porte-bouteilles pour les empêcher de tomber ou de se renverser.
- Tenir les bouteilles éloignées des circuits de soudage ou autres circuits électriques.
- Ne jamais placer une torche de soudage sur une bouteille à gaz.
- Une électrode de soudage ne doit jamais entrer en contact avec une bouteille.
- Ne jamais souder une bouteille pressurisée – risque d'explosion.
- Utiliser seulement des bouteilles de gaz protecteur, régulateurs, tuyaux et raccords convenables pour cette application spécifique; les maintenir ainsi que les éléments associés en bon état.
- Ne pas tenir la tête en face de la sortie en ouvrant la soupape de la bouteille.
- Maintenir le chapeau de protection sur la soupape, sauf en cas d'utilisation ou de branchement de la bouteille.
- Lire et suivre les instructions concernant les bouteilles de gaz comprimé, les équipements associés et les publication P-1 CGA énumérées dans les normes de sécurité.



L'ACIDE DE LA BATTERIE peut provoquer des brûlures dans les YEUX et sur la PEAU.

- Ne pas renverser la batterie.
- Remplacer une batterie endommagée.
- Rincer immédiatement les yeux et la peau à l'eau.



L'EXPLOSION DE LA BATTERIE peut RENDRE AVEUGLE.

- Toujours porter une protection faciale, des gants en caoutchouc et vêtements de protection lors d'une intervention sur la batterie.

- Arrêter le moteur avant de débrancher ou de brancher les câbles de batterie.
- Eviter de provoquer des étincelles avec les outils en travaillant sur la batterie.
- Ne pas utiliser le poste de soudage pour charger les batteries ou des véhicules de démarrage rapide.
- Observer la polarité correcte (+ et -) sur les batteries.
- Débrancher le câble négatif (-) en premier lieu. Le rebrancher en dernier lieu.



LE CARBURANT MOTEUR peut provoquer un incendie ou une explosion.

- Arrêter le moteur avant de vérifier le niveau de carburant ou de faire le plein.
- Ne pas faire le plein en fumant ou proche d'une source d'étincelles ou d'une flamme nue.

- Ne pas faire le plein de carburant à ras bord; prévoir de l'espace pour son expansion.
- Faire attention de ne pas renverser de carburant. Nettoyer tout carburant renversé avant de faire démarrer le moteur.
- Jeter les chiffons dans un récipient ignifuge.



DES ORGANES MOBILES peuvent provoquer des blessures.

- Ne pas approcher les mains des ventilateurs, courroies et autres pièces en mouvement.
- Maintenir fermés et fixement en place les portes, panneaux, recouvrements et dispositifs de protection.

- Arrêter le moteur avant d'installer ou brancher l'appareil.
- Demander seulement à un personnel qualifié d'enlever les dispositifs de sécurité ou les recouvrements pour effectuer, s'il y a lieu, des travaux d'entretien et de dépannage.

2-4. Dangers liés à l'air comprimé



RESPIRER L'AIR COMPRIMÉ peut provoquer des blessures graves ou causer la mort.

- Ne pas utiliser l'air comprimé pour respirer.
- Utiliser l'air comprimé seulement pour le coupage, gougeage et les outils pneumatiques.

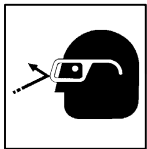

L'AIR COMPRIMÉ peut provoquer des blessures.

- Porter des lunettes de sécurité approuvées.
- Ne pas diriger le jet d'air vers d'autres ou soi-même.

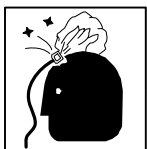

L'AIR COMPRIMÉ EMMAGASINE ET DES TUYAUX SOUS PRESSION peuvent provoquer des blessures.

- Relâcher la pression d'air de l'outillage ou du système avant d'effectuer la maintenance, avant de changer ou de rajouter des éléments ou avant d'ouvrir la purge ou le bouchon de remplissage d'huile.

- Pour empêcher tout démarrage accidentel pendant les travaux d'entretien, débrancher le câble négatif (-) de batterie de la borne.
- Ne pas approcher les mains, cheveux, vêtements lâches et outils des organes mobiles.
- Remettre en place les panneaux ou les dispositifs de protection et fermer les portes à la fin des travaux d'entretien et avant de faire démarrer le moteur.
- Avant d'intervenir, déposer les bougies ou injecteurs pour éviter la mise en route accidentelle du moteur.
- Bloquer le volant moteur pour éviter sa rotation lors d'une intervention sur le générateur.

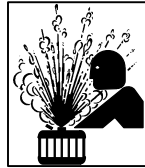

LA VAPEUR ET LE LIQUIDE DE REFROIDISSEMENT CHAUD peuvent provoquer des brûlures.

- Il est préférable de vérifier le liquide de refroidissement une fois le moteur refroidi pour éviter de se brûler.

- Toujours vérifier le niveau de liquide de refroidissement dans le vase d'expansion (si présent), et non dans le radiateur (sauf si précisé autrement dans la section maintenance du manuel du moteur).
- Si le moteur est chaud et que le liquide doit être vérifié, opérer comme suivant :
- Mettre des lunettes de sécurité et des gants, placer un torchon sur le bouchon du radiateur.
- Dévisser le bouchon légèrement et laisser la vapeur s'échapper avant d'enlever le bouchon.



LA CHALEUR DU MOTEUR peut provoquer un incendie.

- Ne pas placer l'appareil sur, au-dessus ou à proximité de surfaces inflammables.
- Tenir à distance les produits inflammables de l'échappement.

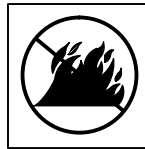

LES ÉTINCELLES À L'ÉCHAPPEMENT peuvent provoquer un incendie.

- Empêcher les étincelles d'échappement du moteur de provoquer un incendie.
- Utiliser uniquement un pare-étincelles approuvé – voir codes en vigueur.

2-5. Dangers supplémentaires en relation avec l'installation, le fonctionnement et la maintenance



LA CHUTE DE L'APPAREIL peut blesser.

- Utiliser l'anneau de levage uniquement pour soulever l'appareil lui-même ; sans chariot, de bouteilles de gaz, remorque, ou autres accessoires.

- Utiliser un équipement de levage de capacité suffisante pour lever l'appareil.
- En utilisant des fourches de levage pour déplacer l'unité, s'assurer que les fourches sont suffisamment longues pour dépasser du côté opposé de l'appareil.

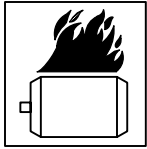

LE SURCHAUFFEMENT peut endommager le moteur électrique.

- Arrêter ou déconnecter l'équipement avant de démarrer ou d'arrêter le moteur.
- Ne pas laisser tourner le moteur trop lentement sous risque d'endommager le moteur électrique à cause d'une tension et d'une fréquence trop faibles.
- Ne pas brancher de moteur de 50 ou de 60 Hz à la prise de 100 Hz, s'il y a lieu.

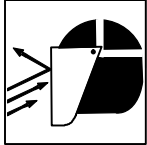

LES ÉTINCELLES VOLANTES risquent de provoquer des blessures.

- Porter un écran facial pour protéger le visage et les yeux.
- Affûter l'électrode au tungstène uniquement à la meuleuse dotée de protecteurs. Cette manoeuvre est à exécuter dans un endroit sûr lorsque l'on porte l'équipement homologué de protection du visage, des mains et du corps.
- Les étincelles risquent de causer un incendie – éloigner toute substance inflammable.

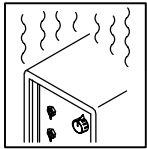

L'EMPLOI EXCESSIF peut SURCHAUFFER L'ÉQUIPEMENT.

- Laisser l'équipement refroidir ; respecter le facteur de marche nominal.
- Réduire le courant ou le facteur de marche avant de poursuivre le soudage.
- Ne pas obstruer les passages d'air du poste.

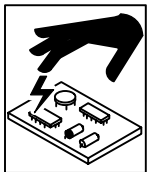

LES CHARGES ÉLECTROSTATIQUES peuvent endommager les circuits imprimés.

- Établir la connexion avec la barrette de terre avant de manipuler des cartes ou des pièces.
- Utiliser des pochettes et des boîtes antistatiques pour stocker, déplacer ou expédier des cartes de circuits imprimés.



UNE REMORQUE QUI BASCULE peut entraîner des blessures.

- Utiliser les supports de la remorque ou des blocs pour soutenir le poids.
- Installer convenablement le poste sur la remorque comme indiqué dans le manuel s'y rapportant.

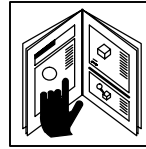

LIRE LES INSTRUCTIONS.

- Utiliser seulement les pièces de rechange d'origine.
- Effectuer la maintenance du moteur et du compresseur (si applicable) suivant ce manuel et le manuel du moteur/compresseur (si applicable).

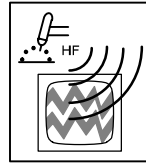

LE RAYONNEMENT HAUTE FRÉQUENCE (H.F.) risque de provoquer des interférences.

- Le rayonnement haute fréquence (H.F.) peut provoquer des interférences avec les équipements de radio-navigation et de communication, les services de sécurité et les ordinateurs.
- Demander seulement à des personnes qualifiées familiarisées avec des équipements électroniques de faire fonctionner l'installation.
- L'utilisateur est tenu de faire corriger rapidement par un électricien qualifié les interférences résultant de l'installation.
- Si le FCC signale des interférences, arrêter immédiatement l'appareil.
- Effectuer régulièrement le contrôle et l'entretien de l'installation.
- Maintenir soigneusement fermés les portes et les panneaux des sources de haute fréquence, maintenir les éclateurs à une distance correcte et utiliser une terre et un blindage pour réduire les interférences éventuelles.

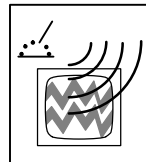

LE SOUDAGE À L'ARC risque de provoquer des interférences.

- L'énergie électromagnétique risque de provoquer des interférences pour l'équipement électronique sensible tel que les ordinateurs et l'équipement commandé par ordinateur tel que les robots.
- Veiller à ce que tout l'équipement de la zone de soudage soit compatible électromagnétiquement.
- Pour réduire la possibilité d'interférence, maintenir les câbles de soudage aussi courts que possible, les grouper, et les poser aussi bas que possible (ex. par terre).
- Veiller à souder à une distance de 100 mètres de tout équipement électronique sensible.
- Veiller à ce que ce poste de soudage soit posé et mis à la terre conformément à ce mode d'emploi.
- En cas d'interférences après avoir pris les mesures précédentes, il incombe à l'utilisateur de prendre des mesures supplémentaires telles que le déplacement du poste, l'utilisation de câbles blindés, l'utilisation de filtres de ligne ou la pose de protecteurs dans la zone de travail.

2-6. Principales normes de sécurité

Safety in Welding, Cutting, and Allied Processes, norme ANSI Z49.1, de l'American Welding Society, 550 N.W. LeJeune Rd, Miami FL 33126 (téléphone : (305) 443-9353, site Web : www.aws.org).

Recommended Safe Practices for the Preparation for Welding and Cutting of Containers and Piping, norme American Welding Society AWS F4.1, de l'American Welding Society, 550 N.W. LeJeune Rd, Miami, FL 33126 (téléphone : (305) 443-9353, site Web : www.aws.org).

National Electrical Code, norme NFPA 70, de la National Fire Protection Association, P.O. Box 9101, 1 Battery March Park, Quincy, MA 02269-9101 (téléphone : (617) 770-3000, sites Web : www.nfpa.org et www.sparky.org).

Safe Handling of Compressed Gases in Cylinders, brochure CGA P-1, de la Compressed Gas Association, 1735 Jefferson Davis Highway, Suite 1004, Arlington, VA 22202-4102 (téléphone : (703) 412-0900, site Web : www.cganet.com).

Code for Safety in Welding and Cutting, norme CSA W117.2, de la Canadian Standards Association, Standards Sales, 178 boulevard Rexdale,

Rexdale (Ontario) Canada M9W 1R3 (téléphone : (800) 463-6727 ou à Toronto : (416) 747-4044, site Web : www.csa-international.org).

Practice For Occupational And Educational Eye And Face Protection, norme ANSI Z87.1, de l'American National Standards Institute, 11 West 42nd Street, New York, NY 10036-8002 (téléphone : (212) 642-4900, site Web : www.ansi.org).

Standard for Fire Prevention During Welding, Cutting, and Other Hot Work, norme NFPA 51B, de la National Fire Protection Association, P.O. Box 9101, 1 Battery March Park, Quincy, MA 02269-9101 (téléphone : (617) 770-3000, site Web : www.nfpa.org et www.sparky.org).

OSHA, Occupational Safety and Health Standards for General Industry, Title 29, Code of Federal Regulations (CFR), Part 1910, Subpart Q, and Part 1926, Subpart J, de l'U.S. Government Printing Office, Superintendent of Documents, P.O. Box 371954, Pittsburgh, PA 15250 (il y a 10 bureaux régionaux – Téléphone pour la Région 5, Chicago : (312) 353-2220, site Web : www.osha.gov).

2-7. Information sur les champs électromagnétiques

Données sur le soudage électrique et les effets des champs magnétiques basse fréquence sur l'organisme

En parcourant les câbles de soudage, le courant crée des champs électromagnétiques. Les effets potentiels de tels champs restent préoccupants. Cependant, après avoir examiné plus de 500 études qui ont été faites pendant une période de recherche de 17 ans, un comité de spécialistes du National Research Council a conclu : « L'accumulation de preuves n'a pas démontré que l'exposition aux champs magnétiques et aux champs électriques à haute fréquence constitue un risque pour la santé humaine ». Toutefois, les études et l'examen des preuves se poursuivent. En attendant les conclusions finales de la recherche, il serait souhaitable de réduire l'exposition aux champs électromagnétiques pendant le soudage ou le coupage.

Afin de réduire les champs électromagnétiques en milieu de travail, respecter les consignes suivantes :

1. Garder les câbles ensemble en les torsadant ou en les fixant avec du ruban adhésif.
2. Mettre tous les câbles du côté opposé à l'opérateur.
3. Ne pas s'enrouler les câbles autour du corps.
4. Garder le poste de soudage et les câbles le plus loin possible de soi.
5. Placer la pince de masse le plus près possible de la zone de soudage.

Consignes relatives aux stimulateurs cardiaques :

Les personnes qui portent un stimulateur cardiaque doivent avant tout consulter leur médecin. Si ce dernier les déclare aptes, il leur est recommandé de respecter les consignes ci-dessus.

SECTION 3 – DEFINITIONS

3-1. Warning Label Definitions (For Wordless Labels)

				<p>Warning! Watch Out! There are possible hazards as shown by the symbols.</p> <p>Become trained and read the instructions before working on the machine or welding.</p>			
1	1.1	1.2	1.3	2	2.1	2.2	2.3
3	3.1	3.2	3.3	4	4.1	5	
6	6.1	6.2	6.3	7	7.1	7.2	

176 105-B

1 Warning! Watch Out! There are possible hazards as shown by the symbols.

2 Do not smoke and keep matches and flames away from battery.

3 Sparks can cause battery gases to explode. Battery explosion can blind and injure. Wear a face shield.

4 Battery acid can burn skin. Do not spill acid.

5 Read Owner's Manual.

6 Wear rubber gloves.

7 Dead battery

8 Engine block

9 Fully charged battery

10 Do not connect last negative cable to dead battery – connect instead to engine block.

11 Jumper cables – observe polarity and make connections in numbered sequence shown.

12 Once dead battery is charged, disconnect cables in sequence shown.

S-176 108

1 Warning! Watch Out! There are possible hazards as shown by the symbols.

2 Moving parts, such as fans, rotors, and belts, can cut fingers and hands and cause injury. Keep away from moving parts.

S-176 106

3/96

1 Caution! Watch Out! There are possible hazards as shown by the symbols.

2 Do not use Ether. Using Ether voids warranty and may damage engine.

DO NOT USE ETHER!

- Using ether voids warranty – see engine manual.

203 260

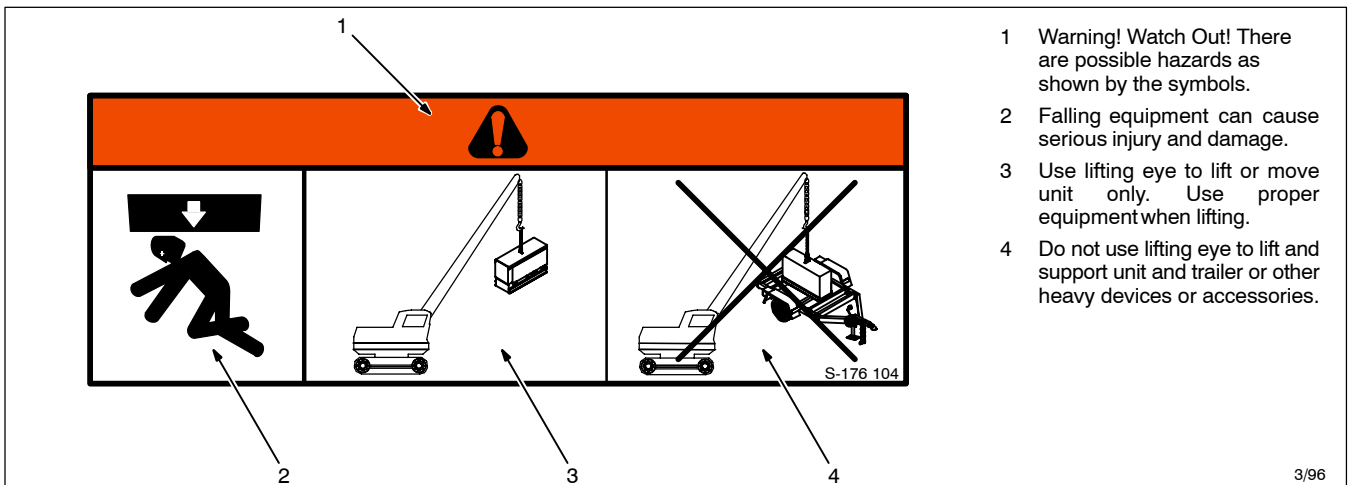
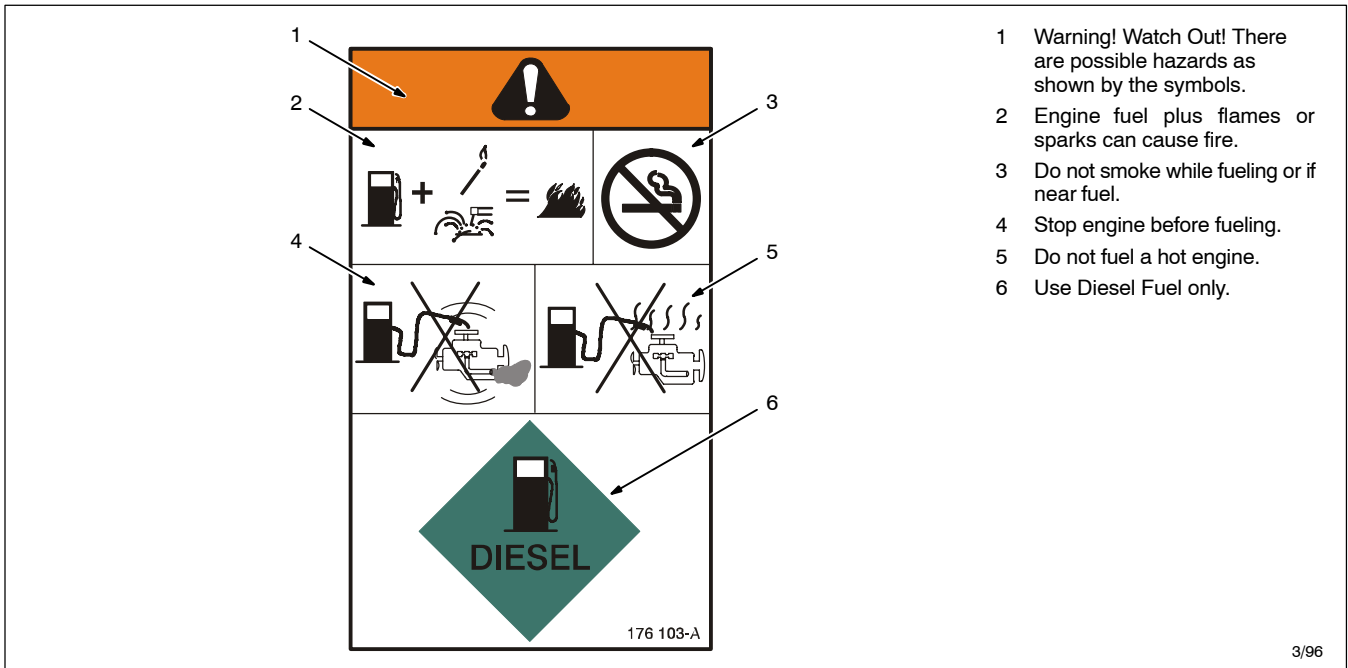
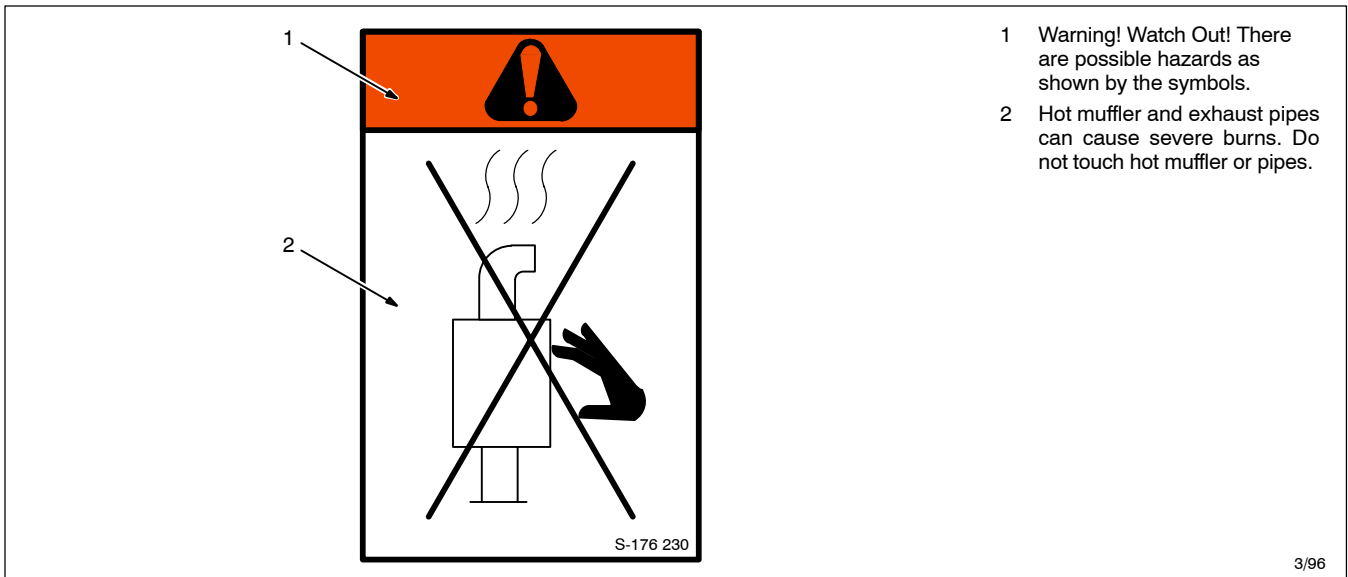

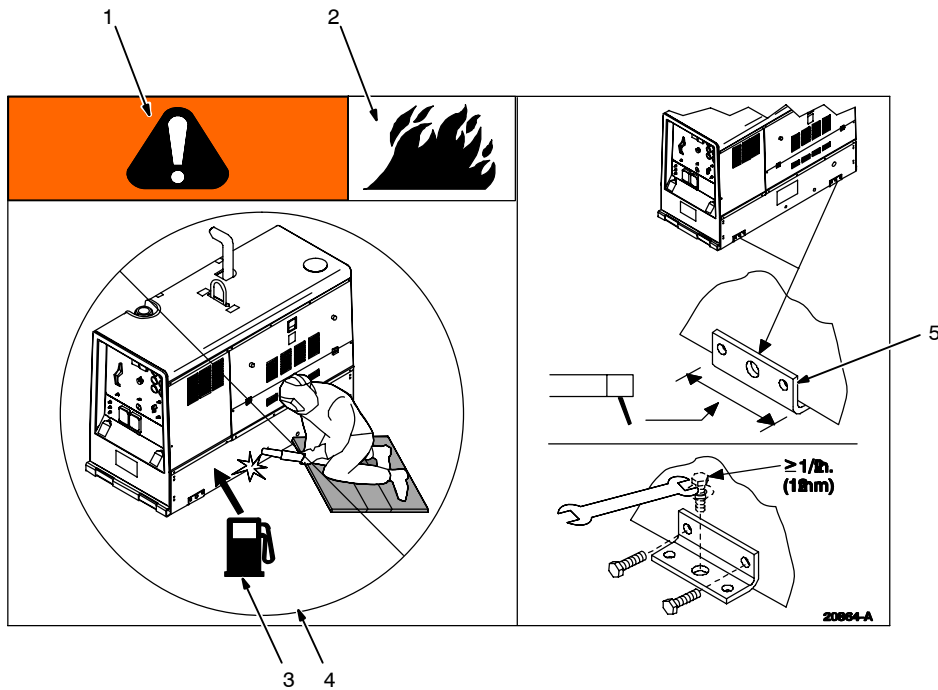

- 1 Warning! Watch Out! There are possible hazards as shown by the symbols.
- 2 Fire hazard from leaking engine fuel. Fire can result from welding on base at non-designated areas causing a possible fuel leak.
- 3 Fuel tank is located inside base.
- 4 Do not weld on base of unit.
- 5 Weld only on supplied brackets or bolt unit down.



- 1 Warning! Watch Out! There are possible hazards as shown by the symbols.
- 2 Electric shock from wiring can kill.
- 3 Moving parts, such as fans, rotors, and belts, can cut fingers and hands and cause injury. Keep away from moving parts.

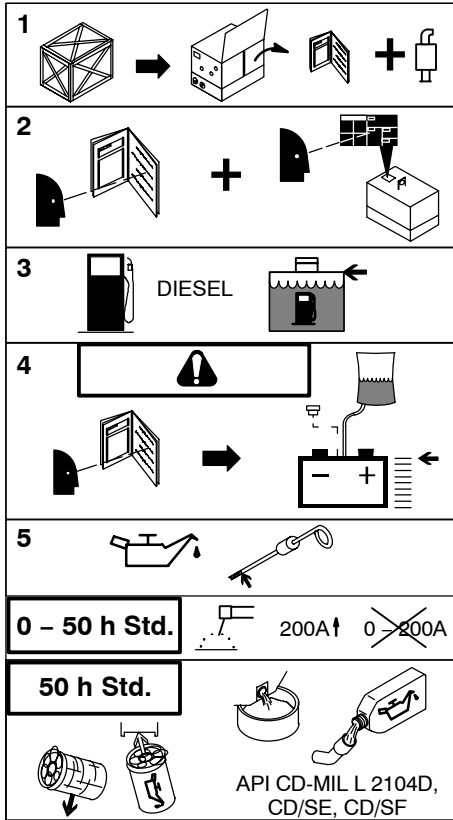

- 1 Remove unit from shipping crate. Remove Owner's Manual from unit. Follow instructions to install muffler.
- 2 Read Owner's Manual. Read labels on unit.
- 3 Use Diesel Fuel only, and fill fuel tank. Leave room for expansion.
- 4 Warning! Watch Out! There are possible hazards as shown by the symbols. Read Owner's Manual. Follow instructions to activate battery.
- 5 Check oil level. Add oil if necessary.
- 6 During the first 50 hours of operation, keep welding load above 200 amperes. Do not weld below 200 amperes of output.
- 7 After the first 50 hours of operation, change the oil and oil filter.

3-2. Manufacturer's Rating Labels

CC Models



















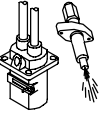
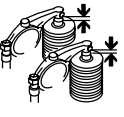





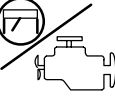





ISO / IEC 60974-1					
	=	55A/22V to 500A/30V			
		X	40%	60%	100%
		I_2	500A	450A	400A
$U_0 = 92V$		U_2	30V	38V	38V
	=	55A/12V to 500A/30V			
		X	40%	60%	100%
		I_2	500A	450A	400A
$U_0 = 92V$		U_2	30V	28V	28V
	~	40A/22V to 375A/35V			
		X	40%	60%	100%
		I_2	375A	335A	300A
$U_0 = 64V$		U_2	35V	33V	32V
	~	40A/12V to 375A/25V			
		X	40%	60%	100%
		I_2	375A	335A	300A
$U_0 = 64V$		U_2	25V	23V	22V
	n = 1800 min ⁻¹				
	$n_0 = 1850 \text{ min}^{-1}$	$*n_1 = 1235 \text{ min}^{-1}$			
IP 23					
1 ~ 60 Hz	120/240V	4kVA	20/17A		
*Optional					

CC/CV Models

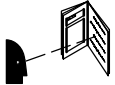
ISO / IEC 60974-1					
	=	45A/22V to 500A/34V			
		X	40%	60%	100%
		I_2	500A	450A	400A
$U_0 = 92V$		U_2	34V	38V	38V
	=	15A/11V to 350A/24V			
		X			100%
		I_2			350A
$U_0 = 48V$		U_2		24V	
	=	20A/15V to 500A/34V			
		X	40%	60%	100%
		I_2	500A	450A	400A
$U_0 = 56V$		U_2	34V	36V	34V
	~	25A/21V to 375A/35V			
		X	40%	60%	100%
		I_2	375A	335A	300A
$U_0 = 64V$		U_2	35V	33V	32V
	~	15A/11V to 375A/25V			
		X	40%	60%	100%
		I_2	375A	335A	300A
$U_0 = 94V$		U_2	25V	23V	22V
	n = 1800 min ⁻¹				
	$n_0 = 1850 \text{ min}^{-1}$	$*n_1 = 1235 \text{ min}^{-1}$			
IP 23					
1 ~ 60 Hz	120/240V	4kVA	20/17A		
*1 ~ 60 Hz	120/240V	12kVA	50/50A		
*3 ~ 60 Hz	240V	15kVA	38A		
*Optional					

3-3. Symbols And Definitions

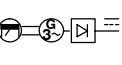
NOTE  Some symbols are found only on CE products.

	Stop Engine		Fast (Run, Weld/ Power)		Slow (Idle)		Start Engine
	Starting Aid		Battery (Engine)		Engine Oil Pressure		Engine Oil
	Check Injectors/ Pump		Check Valve Clearance		Fuel		Protective Earth (Ground)
+	Positive	-	Negative		Certified/Trained Mechanic		Welding Arc
A	Amperes	V	Volts		Panel/Local		Remote
	Engine		Air Temperature Or Engine Temperature		Output		Alternating Current
	Stick (SMAW) Welding		Constant Current (CC)		MIG (GMAW) Welding		TIG (GTAW)
	Time	h	Hours	s	Seconds		Single Phase
	Three Phase		Read Operator's Manual		Circuit Breaker		Do Not Switch While Welding
	Electrode Connection		Work Connection		Engine-Driven, Three-Phase Alternator With Rectifier	Hz	Hertz
X	Duty Cycle	U₀	Rated No Load Voltage (Average)	U₂	Conventional Load Voltage	n	Rated Load Speed
n₁	Rated Idle Speed	n₀	Rated No Load Speed	I	Current	I₂	Rated Welding Current
	Contactor On						

SECTION 4 – SPECIFICATIONS

4-1. Weld, Power, And Engine Specifications

Welding Mode	Weld Output Range	Rated Welding Output	Maximum Open-Circuit Voltage	Generator Power Rating	Engine	Fuel Capacity
CC/DC	55 – 500 A (CC Models) 15 – 500 A (CC/CV Models)	400 A, 36 Volts DC, 100% Duty Cycle 450 A, 38 Volts DC, 60% Duty Cycle	95	Standard Single-Phase, 4 kVA/kW, 34/17 A, 120/240 V AC, 50/60 Hz Three-Phase Generator Option* Single-Phase/Three-Phase, 12/15 kVA/kW, 50/36A, 120/240 VAC, 60 Hz *In Addition To Standard 4 kVA/kW Generator Power	 DEUTZ Deutz F3L2011 Air/Oil-Cooled, Three Cylinder, 33 HP Diesel Engine	25 gal (95 L)
CV/DC (CC/CV Models Only)	14 – 40 V	500 A, 30 Volts DC (CC), 34 Volts DC (CV), 40% Duty Cycle	56			

4-2. Dimensions, Weights, And Operating Angles

Dimensions	
Height	60 in (1524 mm) (to top of muffler)
Width	28-1/2 in (724 mm) (mtg. brackets turned in)
	30-3/4 in (781 mm) (mtg. brackets turned out)
Depth	65-1/8 in (1654 mm)
A	65-1/8 in (1654 mm)
B*	56 in (1422 mm)
C*	46-1/2 in (1181)
D*	9-5/8 in (244 mm)
E	27-1/2 in (699 mm)
F	1 in (25 mm)
G	29-1/2 in (743 mm)
H	9/16 in (14 mm) Dia. 4 Holes
* With mounting brackets in center position. Dimensions vary with location of mounting brackets.	
Weight	
w/ Deutz F3L2011	No fuel: 1600 lb (726 kg) w/fuel: 1775 lb (805 kg)

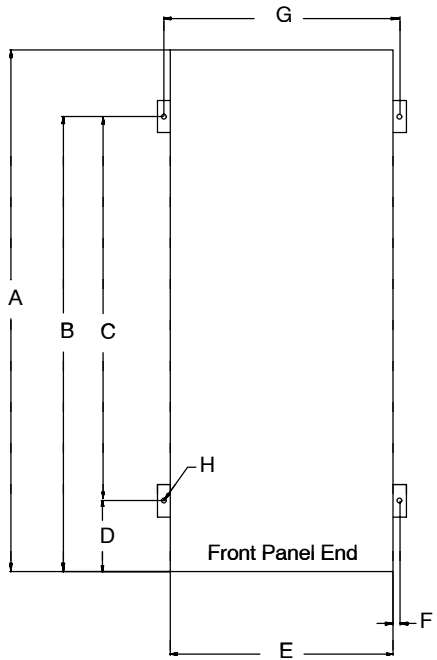



- ▲ Do not exceed tilt angles or engine could be damaged or unit could tip.
- ▲ Do not move or operate unit where it could tip.

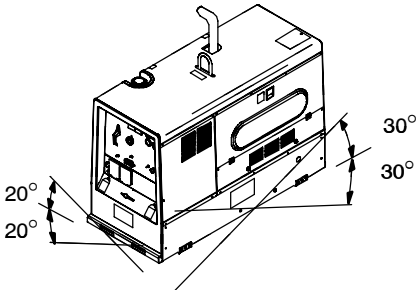

802 161-A

4-4. Volt-Ampere Curves For CC/CV Models

A. Stick Mode

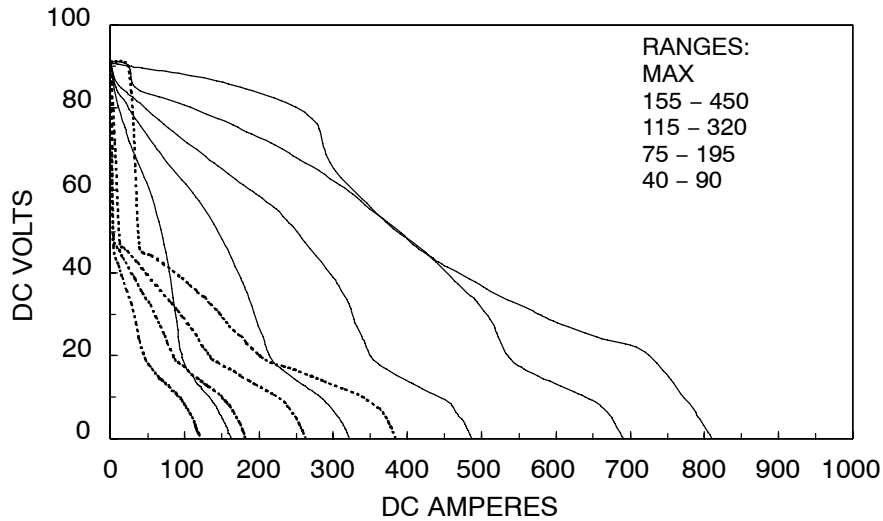

The volt-ampere curves show the minimum and maximum voltage and amperage output capabilities of the welding generator. Curves of all other settings fall between the curves shown.

B. MIG Mode

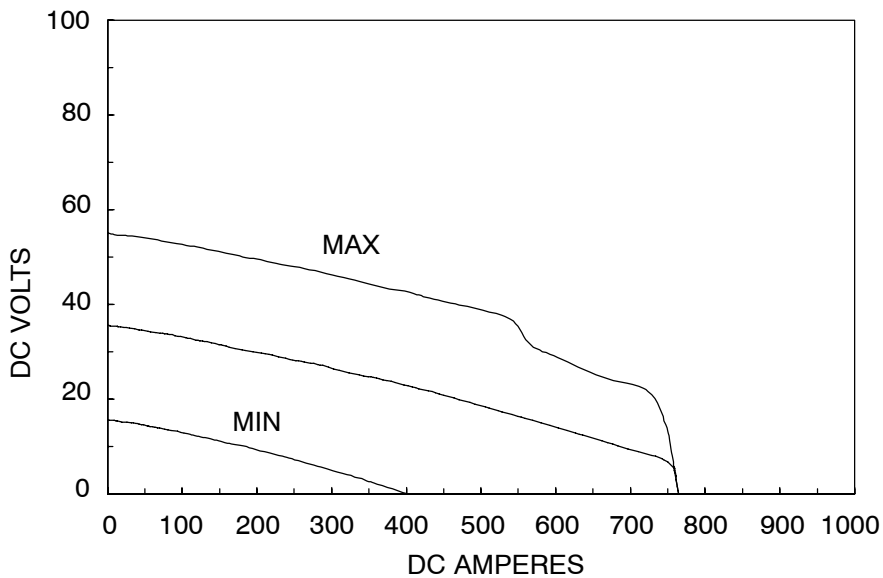

C. TIG Mode

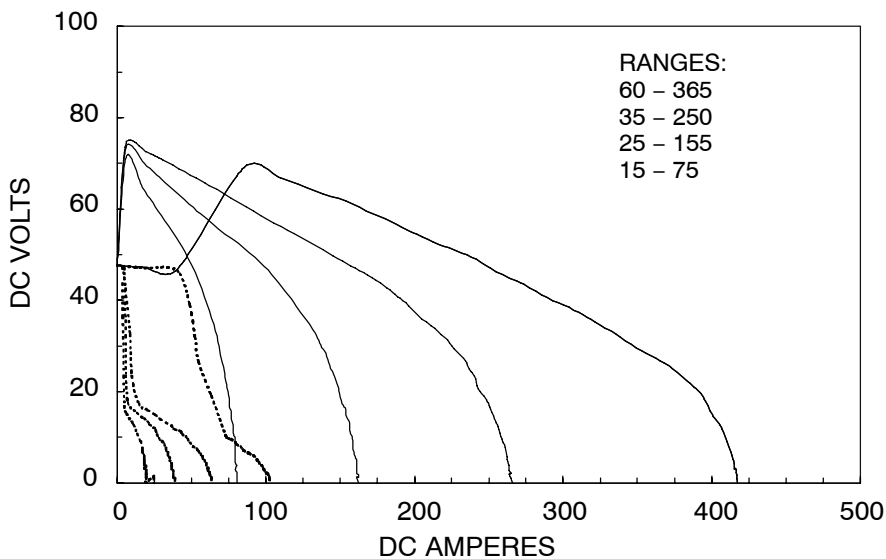

4-5. Fuel Consumption

The curve shows typical fuel use under weld or power loads.

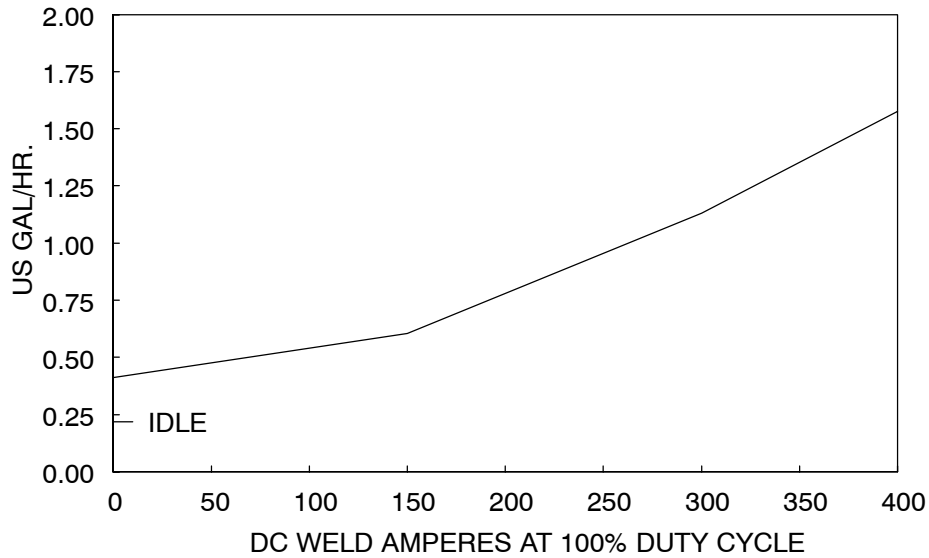

199 032

4-6. Duty Cycle And Overheating



100% Duty Cycle At 400 Amperes



Continuous Welding

Duty Cycle is percentage of 10 minutes that unit can weld at rated load without overheating.

▲ Exceeding duty cycle can damage unit and void warranty.

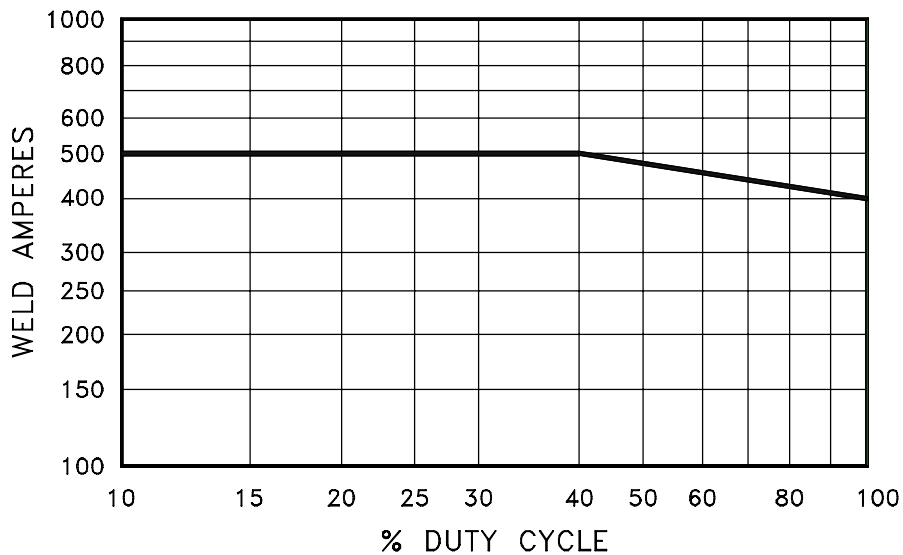

215 084-A

4-7. AC Generator Power Curve

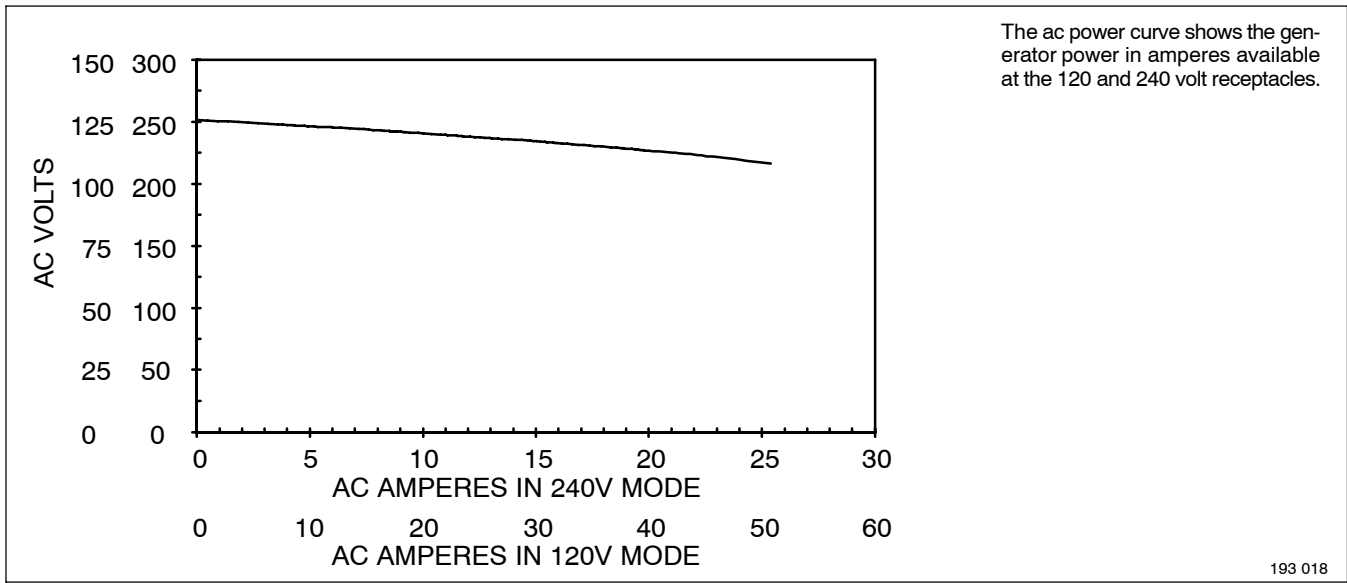

4-8. Optional Three-Phase Generator Curves

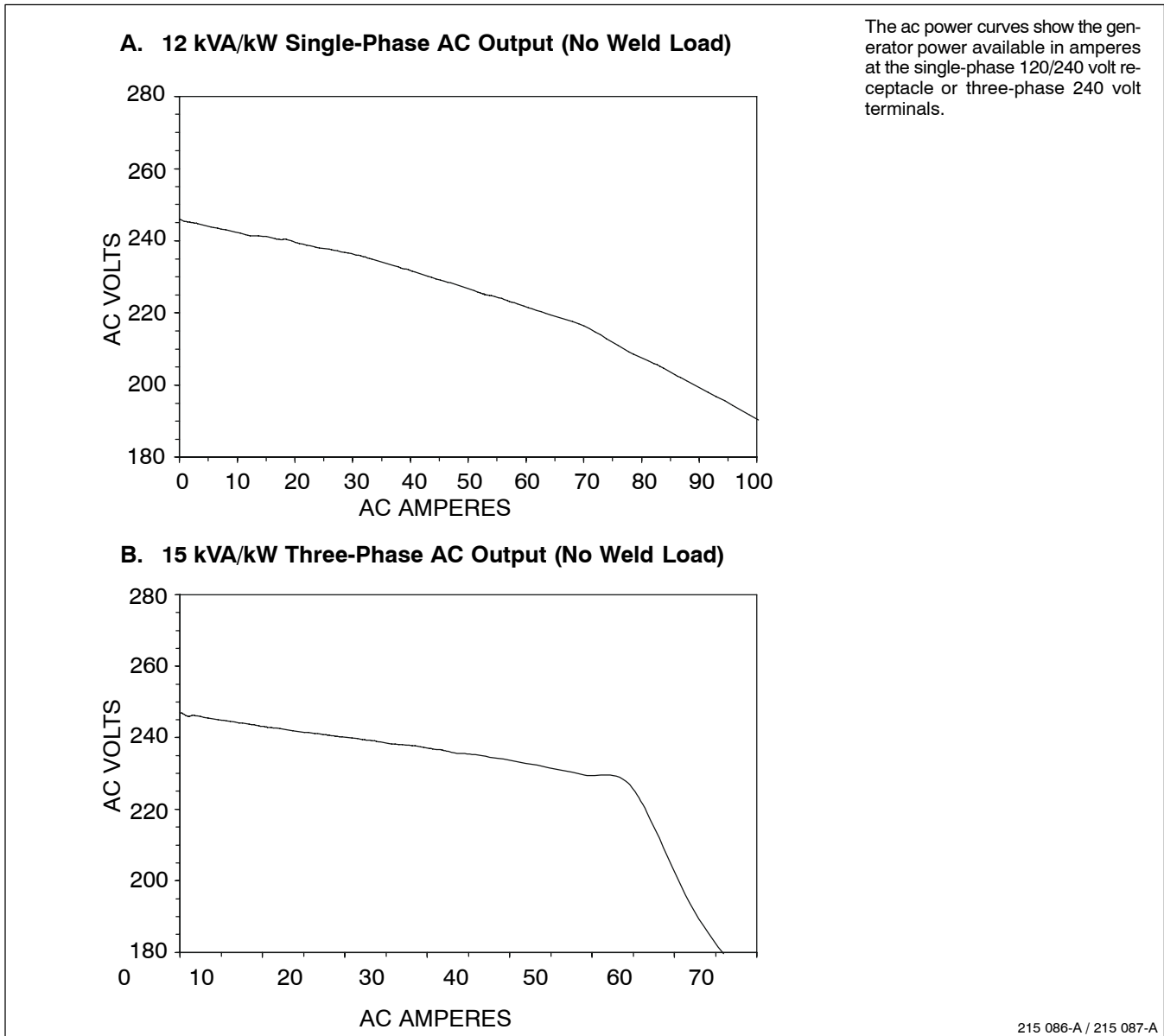

SECTION 5 – INSTALLATION

5-1. Installing Welding Generator

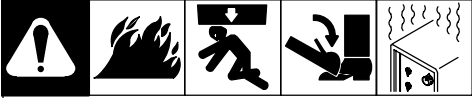

Movement

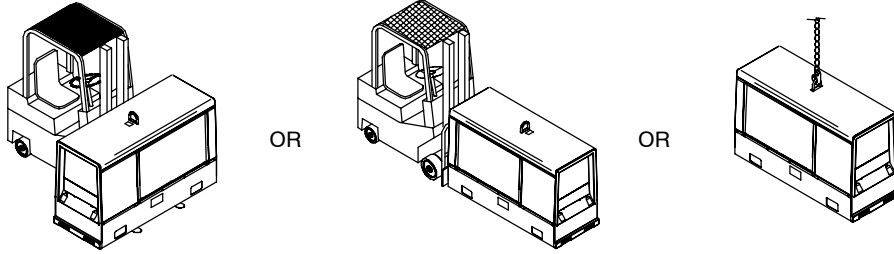

▲ Always securely fasten welding generator onto transport vehicle or trailer and comply with all DOT and other applicable codes.

▲ Always ground generator frame to vehicle frame to prevent electric shock and static electricity hazards.

▲ If unit does not have GFCI receptacles, use GFCI-protected extension cord.

☞ See Section 5-3 for mounting information.

Grounding:

- 1 Equipment Grounding Terminal (On Front Panel)
- 2 Grounding Cable (Not Supplied)
- 3 Metal Vehicle Frame

Connect cable from equipment ground terminal to metal vehicle frame. Use #10 AWG or larger insulated copper wire.

Location

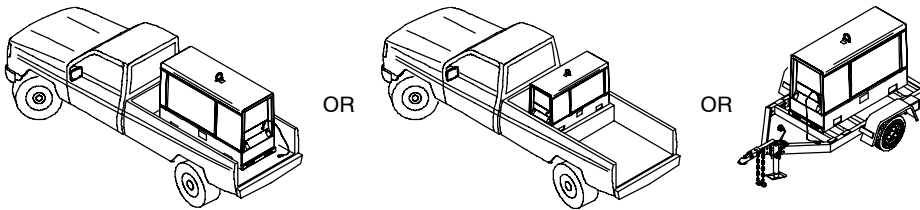

Grounding

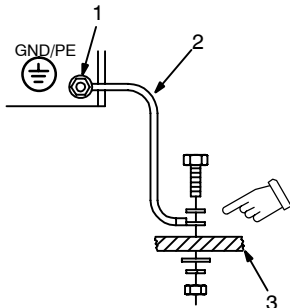

Electrically bond generator frame to vehicle frame by metal-to-metal contact.

▲ Bed liners, shipping skids, and some running gears insulate the welding generator from the vehicle frame. Always connect a ground wire from the generator equipment grounding terminal to bare metal on the vehicle frame as shown.

Airflow Clearance

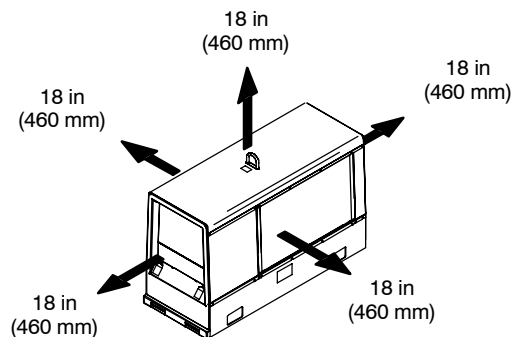

5-3. Mounting Welding Generator



Supporting The Unit

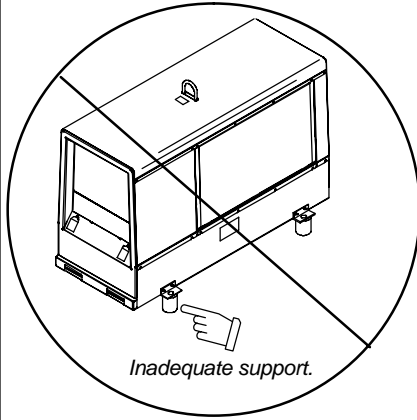

▲ Do not use flexible mounts.

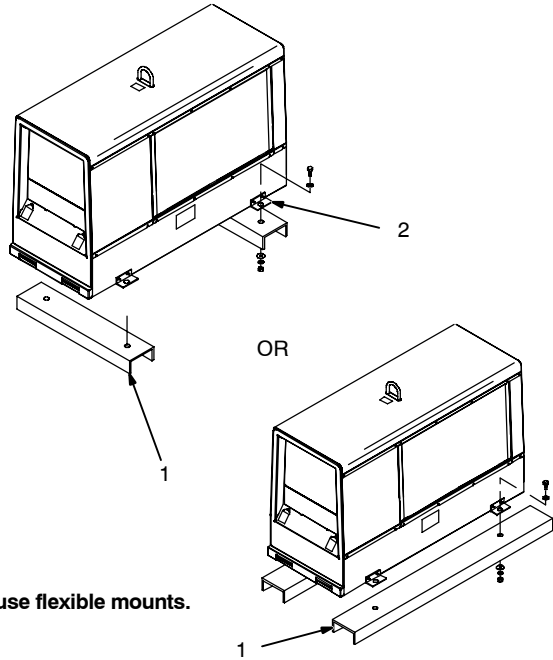

▲ Do not weld on base. Welding on base can cause fuel tank fire or explosion. Weld only on the four mounting brackets or bolt unit down.

▲ Do not mount unit by supporting the base only at the four mounting brackets. Use cross-supports to adequately support unit and prevent damage to base.

Mounting Surface:

- 1 Cross-Supports
- 2 Mounting Brackets (Supplied)

Mount unit on flat surface or use cross-supports to support base. Secure unit with mounting brackets.

- 3 1/2 in Bolt And Washer (Minimum – Not Supplied)
- 4 3/8-16 x 1 in Screws (Supplied)

To Bolt Unit In Place:

Remove hardware securing the four mounting brackets to the base. Reverse brackets and reattach to base with original hardware.

Mount unit to truck or trailer with 1/2 in (12 mm) or larger hardware (not supplied).

To Weld Unit In Place:

Weld unit to truck or trailer only at the four mounting brackets.

Using Mounting Brackets

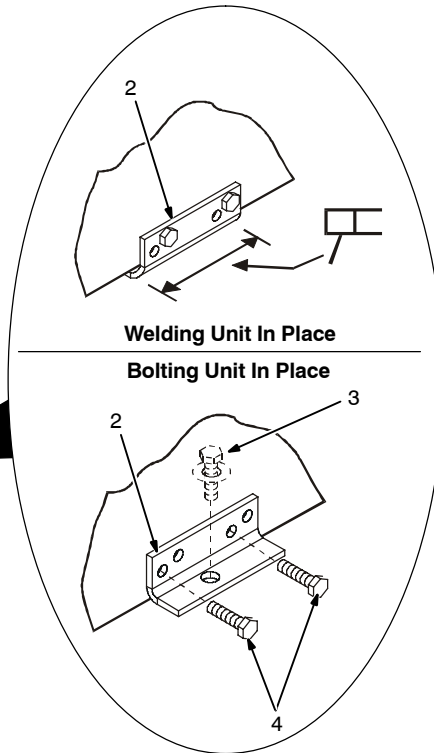
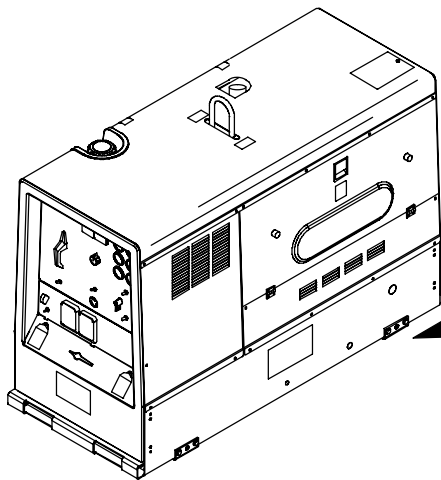

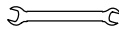
Tools Needed:
 9/16 in

install3 6/04 803 274 / 190 250-A / 803 231 / 802 311

5-5. Activating The Dry Charge Battery (If Applicable)

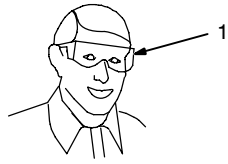
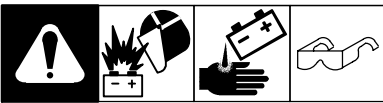

1



2

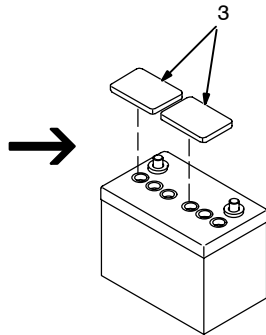

3

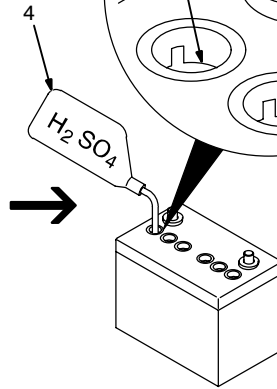

4

5

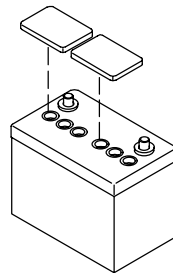
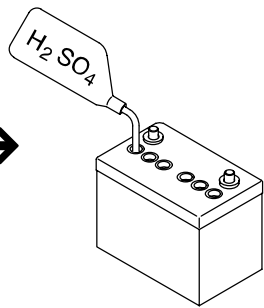
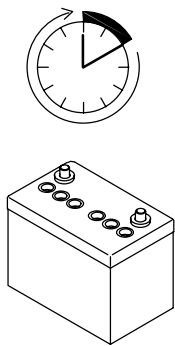

5 A For 30 Minutes

OR



30 A For 12 Minutes

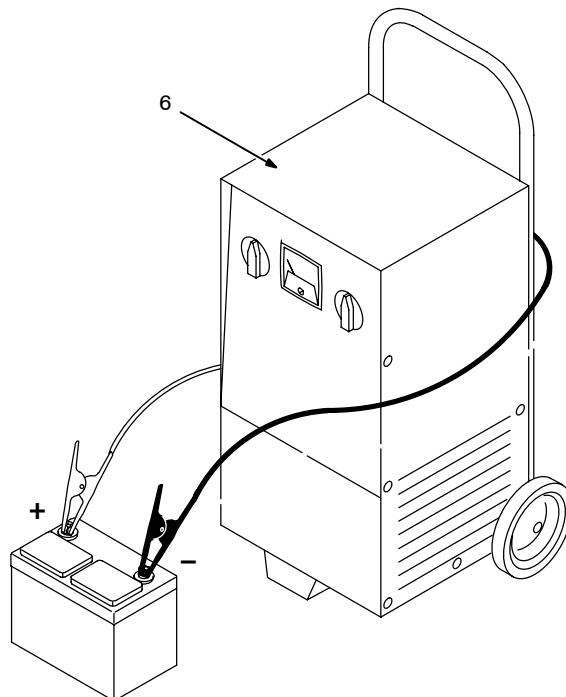

6

Remove battery from unit.

- 1 Eye Protection – Safety Glasses Or Face Shield
- 2 Rubber Gloves
- 3 Vent Caps
- 4 Sulfuric Acid Electrolyte (1.265 Specific Gravity)
- 5 Well

Fill each cell with electrolyte to **bottom** of well (maximum).

▲ **Do not overfill battery cells.**

Wait ten minutes and check electrolyte level. If necessary, add electrolyte to raise to proper level. Reinstall vent caps.

- 6 Battery Charger

▲ **Read and follow all instructions supplied with battery charger.**

Charge battery for 12 minutes at 30 amperes or 30 minutes at 5 amperes. Disconnect charging cables and install battery.

☞ *When electrolyte is low, add only distilled water to cells to maintain proper level.*

Tools Needed:

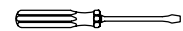

rubber gloves



glasses

drybatt1 1/98 - 0886

5-7. Engine Prestart Checks

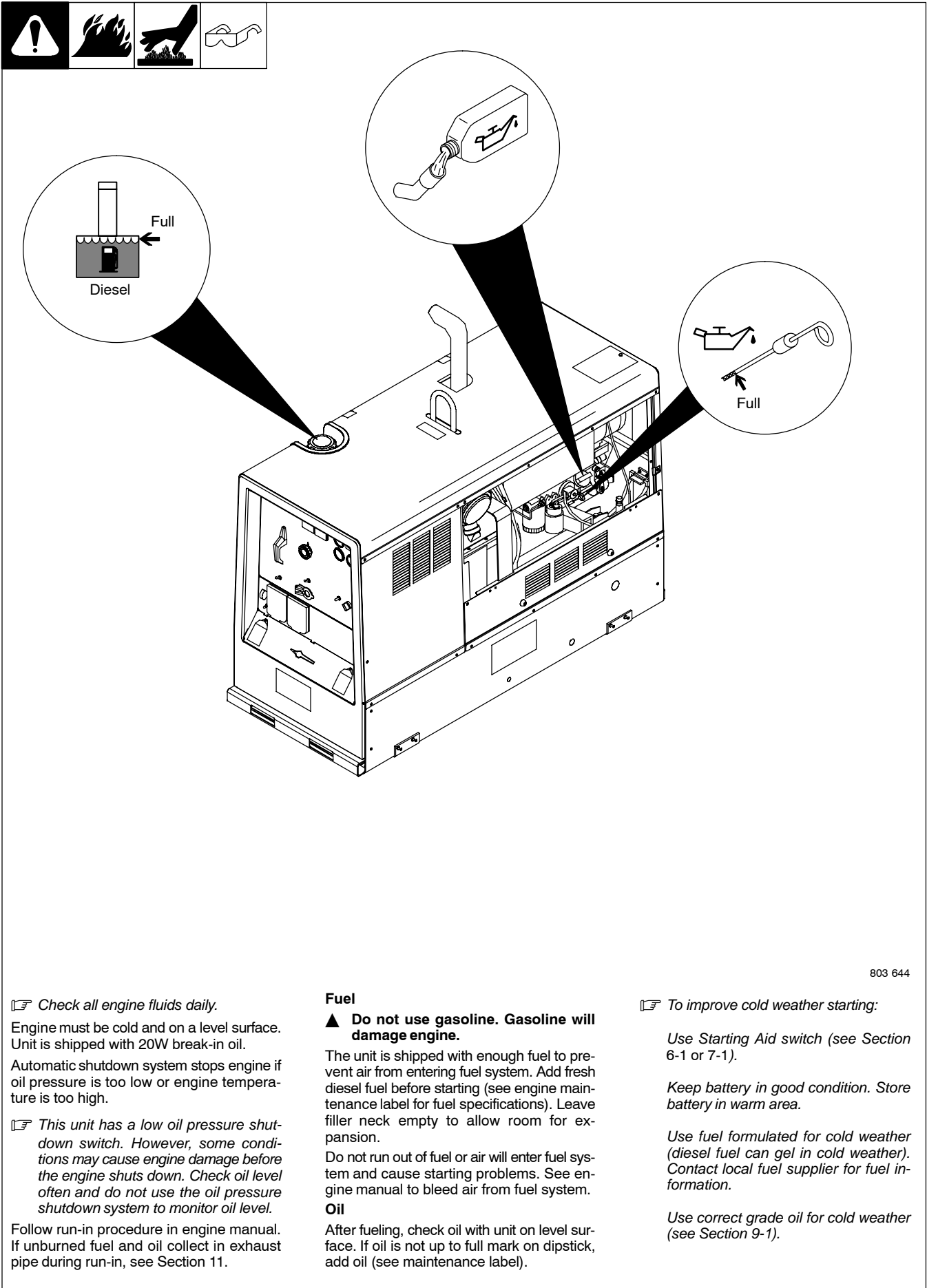

803 644

☞ Check all engine fluids daily.

Engine must be cold and on a level surface. Unit is shipped with 20W break-in oil.

Automatic shutdown system stops engine if oil pressure is too low or engine temperature is too high.

☞ This unit has a low oil pressure shutdown switch. However, some conditions may cause engine damage before the engine shuts down. Check oil level often and do not use the oil pressure shutdown system to monitor oil level.

Follow run-in procedure in engine manual. If unburned fuel and oil collect in exhaust pipe during run-in, see Section 11.

Fuel

▲ Do not use gasoline. Gasoline will damage engine.

The unit is shipped with enough fuel to prevent air from entering fuel system. Add fresh diesel fuel before starting (see engine maintenance label for fuel specifications). Leave filler neck empty to allow room for expansion.

Do not run out of fuel or air will enter fuel system and cause starting problems. See engine manual to bleed air from fuel system.

Oil

After fueling, check oil with unit on level surface. If oil is not up to full mark on dipstick, add oil (see maintenance label).

☞ To improve cold weather starting:

Use Starting Aid switch (see Section 6-1 or 7-1).

Keep battery in good condition. Store battery in warm area.

Use fuel formulated for cold weather (diesel fuel can gel in cold weather). Contact local fuel supplier for fuel information.

Use correct grade oil for cold weather (see Section 9-1).

5-8. Connecting To Weld Output Terminals

Tools Needed:
 3/4 in

▲ Stop engine.

- 1 Positive (+) Weld Output Terminal
- 2 Negative (-) Weld Output Terminal

Stick and TIG Welding

For Stick and TIG welding Direct Current Electrode Positive (DCEP), connect electrode holder cable to Positive (+) terminal on left and work cable to Negative (-) terminal on right.

For Direct Current Electrode Negative (DCEN), reverse cable connections.

If equipped with optional Polarity switch or optional Polarity/AC switch, connect electrode holder cable to Electrode (+) terminal on left and work cable to Work (-) terminal on right.

MIG and FCAW Welding

For MIG and FCAW welding Direct Current Electrode Positive (DCEP) on CC/CV models, connect wire feeder cable to Positive (+) terminal on left and work cable to Negative (-) terminal on right. Use Process/Contactor switch to select type of weld output (see Section 7-3).

For Direct Current Electrode Negative (DCEN), reverse cable connections.

If equipped with optional Polarity switch or optional Polarity/AC switch, connect wire feeder cable to Electrode (+) terminal on left and work cable to Work (-) terminal on right.

803 602

5-9. Selecting Weld Cable Sizes*

<p>Weld Output Terminals</p> <p>▲ Stop engine before connecting to weld output terminals.</p> <p>▲ Do not use worn, damaged, undersized, or poorly spliced cables.</p>		Weld Cable Size** and Total Cable (Copper) Length in Weld Circuit Not Exceeding***							
		100 ft (30 m) or Less		150 ft (45 m)	200 ft (60 m)	250 ft (70 m)	300 ft (90 m)	350 ft (105 m)	400 ft (120 m)
		Welding Amperes	10 – 60% Duty Cycle	60 – 100% Duty Cycle	10 – 100% Duty Cycle				
100	4 (20)	4 (20)	4 (20)	3 (30)	2 (35)	1 (50)	1/0 (60)	1/0 (60)	
150	3 (30)	3 (30)	2 (35)	1 (50)	1/0 (60)	2/0 (70)	3/0 (95)	3/0 (95)	
200	3 (30)	2 (35)	1 (50)	1/0 (60)	2/0 (70)	3/0 (95)	4/0 (120)	4/0 (120)	
250	2 (35)	1 (50)	1/0 (60)	2/0 (70)	3/0 (95)	4/0 (120)	2 ea. 2/0 (2x70)	2 ea. 2/0 (2x70)	
300	1 (50)	1/0 (60)	2/0 (70)	3/0 (95)	4/0 (120)	2 ea. 2/0 (2x70)	2 ea. 3/0 (2x95)	2 ea. 3/0 (2x95)	
350	1/0 (60)	2/0 (70)	3/0 (95)	4/0 (120)	2 ea. 2/0 (2x70)	2 ea. 3/0 (2x95)	2 ea. 3/0 (2x95)	2 ea. 4/0 (2x120)	
400	1/0 (60)	2/0 (70)	3/0 (95)	4/0 (120)	2 ea. 2/0 (2x70)	2 ea. 3/0 (2x95)	2 ea. 4/0 (2x120)	2 ea. 4/0 (2x120)	
500	2/0 (70)	3/0 (95)	4/0 (120)	2 ea. 2/0 (2x70)	2 ea. 3/0 (2x95)	2 ea. 4/0 (2x120)	3 ea. 3/0 (3x95)	3 ea. 3/0 (3x95)	

*Chart is a general guideline and may not suit all applications. If cables overheat, use next size larger cable.

**Weld cable size (AWG) is based on either a 4 volts or less drop or a current density of at least 300 circular mils per ampere.
 () = mm² for metric use

S-0007-F-

***For distances longer than those shown in this guide, call a factory applications representative at 920-735-4505.

5-11. Connecting To Remote 14 Receptacle RC14 On CC/CV Models

REMOTE 14	Socket*	Socket Information
24 VOLTS AC OUTPUT (CONTACTOR)	A	24 volts ac. Protected by circuit breaker CB5.
	B	Contact closure to A completes 24 volt ac contactor control circuit.
REMOTE OUTPUT CONTROL	C	Output to remote control: +10 volts dc in MIG or Stick mode; 0 to +10 volts dc in TIG mode.
	D	Remote control circuit common.
	E	DC input command signal: 0 to +10 volts from min. to max. of remote control with Voltage/ Amperage Adjust control at max.
115 VOLTS AC OUTPUT (CONTACTOR)	I	115 volts, 10 amperes, 60 Hz ac. Protected by circuit breaker CB6.
	J	Contact closure to I completes 115 volt ac contactor control circuit.
GND	K	Chassis common.
NEUTRAL	G	Circuit common for 24 and 115 volt ac circuit.

Ref. 803 602

*The remaining sockets are not used.

Notes



HOBART INSTITUTE
OF WELDING TECHNOLOGY

400 Trade Square East, Troy, Ohio 45373
1-800-332-9448 www.welding.org

**Start Your Professional
Welding Career Now!**

**Over 80,000 trained
since 1930!**

SECTION 6 – OPERATING WELDING GENERATOR – CC MODELS

6-1. Front Panel Controls For CC Models (See Section 6-2)

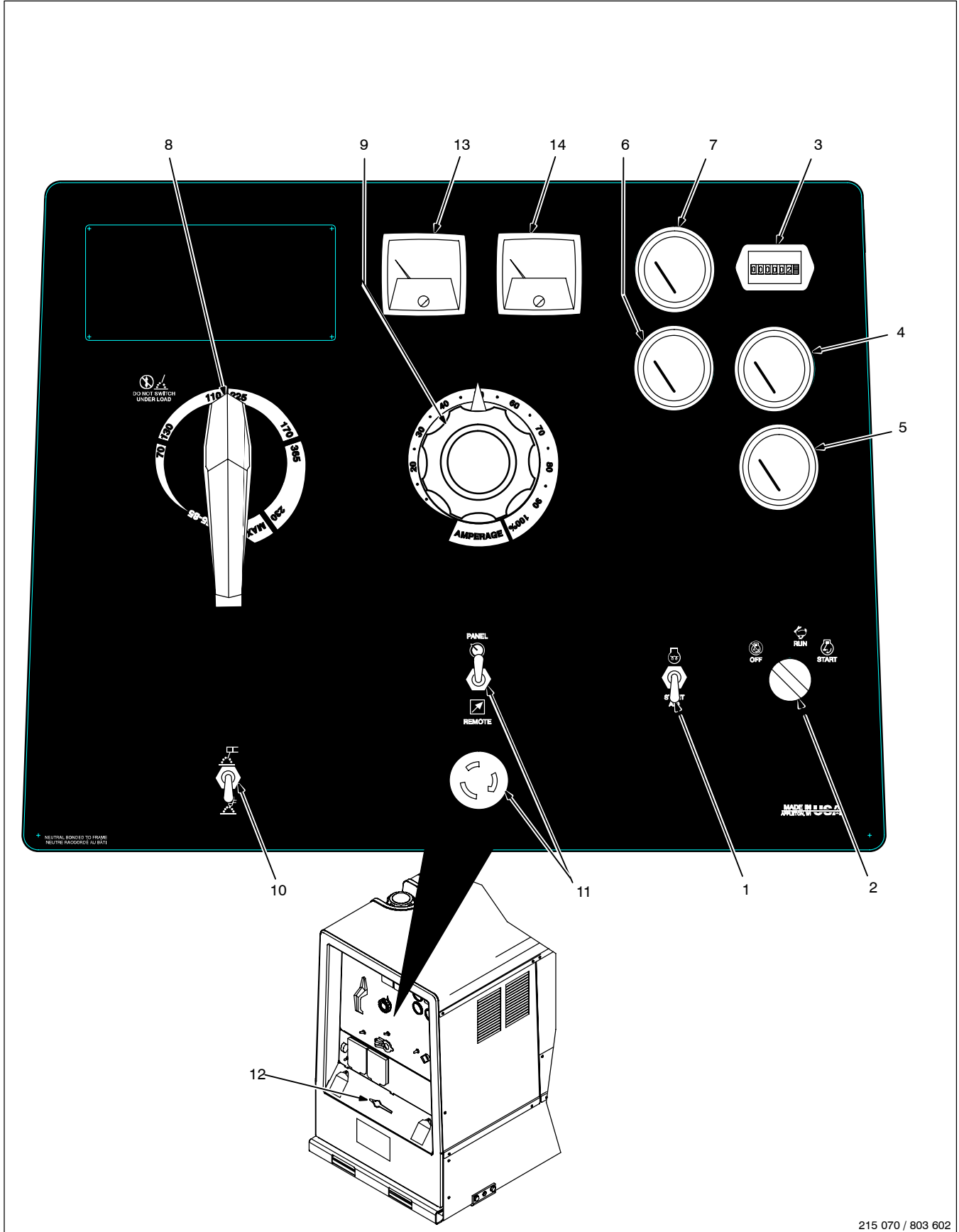

6-2. Description Of Front Panel Controls For CC Models (See Section 6-1)

<p>Engine Starting Controls</p> <p>1 Starting Aid Switch Use switch to energize starting aid for cold weather starting (see starting instructions following).</p> <p>2 Engine Control Switch Use switch to start and stop engine.</p> <p>To Start:</p> <p>▲ Do not use ether. Using ether voids warranty.</p> <p>☞ <i>If engine does not start, let engine come to a complete stop before attempting re-start.</i></p> <p>Above 32° F (0° C): turn Engine Control switch to Start. Release Engine Control switch when engine starts.</p> <p>Below 32° F (0° C): push Starting Aid switch up for 60 seconds. While still holding Starting Aid switch, turn Engine Control switch to Start. Release Engine Control switch and Starting Aid switch when engine starts.</p> <p>To Stop: turn Engine Control switch to Off position.</p> <p>Engine Gauges And Meters</p> <p>3 Engine Hour Meter Use hour meter to monitor engine run time to help schedule maintenance.</p> <p>4 Fuel Gauge Use gauge to check fuel level. To check fuel level when engine is not running, turn Engine Control switch to Run position.</p> <p>5 Battery Voltmeter (Optional) Use gauge to check battery voltage and monitor the engine charging system. The meter should read about 14 volts dc when the engine is running, and about 12 volts dc when the engine is stopped.</p> <p>6 Engine Temperature Gauge Normal temperature is 180 - 203° F (82 - 95° C). Engine stops if temperature exceeds 220° F (104° C).</p> <p>7 Engine Oil Pressure Gauge Normal pressure is 30 - 60 psi (207 - 414 kPa). Engine stops if pressure is below 10 psi (69 kPa).</p> <p>Weld Controls</p> <p>☞ Max OCV Control Circuit: <i>This unit has a max OCV control circuit that resets Amperage Adjust control R1 to maximum when the arc breaks. When an arc is struck, weld output control returns to the R1 front panel or combination front panel/remote control setting. The Amperage Adjust control adjusts amperage only when welding and does not adjust open-circuit voltage.</i></p> <p><i>The max OCV circuit is disabled when the Stick/TIG Selection switch is in Scratch Start TIG position (see item 10).</i></p> <p>8 Ampere Range Switch ▲ Do not switch under load. Use switch to select weld amperage range. For most welding applications, use lowest amperage range possible to help prevent arc outages.</p> <p>9 Amperage Adjust Control Control adjusts amperage within range selected by Ampere Range switch. Weld output would be about 168 A DC with controls set as shown (50% of 110 to 225 A).</p> <p>☞ <i>The numbers around the control are for reference only and do not represent an actual percentage value.</i></p> <p>10 Stick/TIG Selection Switch Use switch to disable the max OCV circuit and the arc drive (dig) circuit for scratch start TIG welding (see max OCV note under Weld Controls). When switch is in the Stick position, the max OCV circuit resets Amperage Adjust Control R1 to maximum when the arc breaks. Also in the Stick position, the arc drive (dig) circuit provides additional amperage during low voltage (short arc length conditions) to prevent "sticking" electrodes. When switch is in Scratch Start TIG position, the max OCV and arc drive (dig) circuits are disabled and OCV changes when the control is adjusted.</p> <p>11 Amperage Adjust Switch And Remote Amperage Adjust Receptacle Connect optional remote control to RC13 (See Section 5-10). Use switch to select front panel or remote amperage control. For remote control, place switch in Remote position and connect remote control to Remote Amperage Adjust receptacle RC13 (see Sections 5-10 and 6-3).</p> <p>12 Polarity Switch (Optional) ▲ Do not switch under load. Use switch to change weld output. Select either DC Electrode Positive (DCEP) or DC Electrode Negative (DCEN).</p> <p>Weld Meters</p> <p>13 AC/DC Voltmeter (Optional) Voltmeter displays voltage at the weld output terminals, but not necessarily the welding arc due to resistance of cable and connections.</p> <p>14 AC/DC Ammeter (Optional) Ammeter displays amperage output of the unit.</p>													

6-3. Remote Amperage Control On CC Models (Optional)



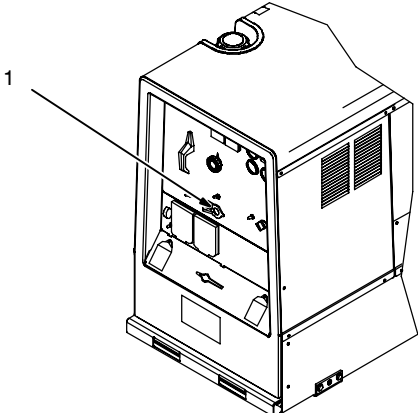

1 Remote Amperage Adjust Receptacle RC13

Connect optional remote control to RC13 (see Section 5-10).

Example: Combination Remote Amperage Control (Stick)

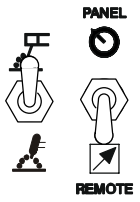

Set Switches

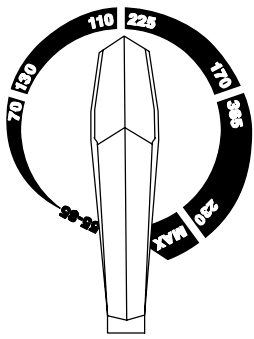

Set Range

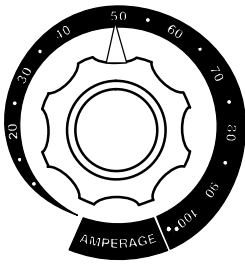

Set Control

In Example:
Range = 110 to 225 A DC
Percentage Of Range = 50%
Max = About 168 A DC (50% of 110 to 225)

Max (168 A DC)

Min (90 A DC)

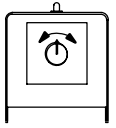

Adjust Optional Remote Control

Ref. 154 862-A / Ref. 181 711-A / 803 602

6-4. Weld Control/Arc Condition Information Label

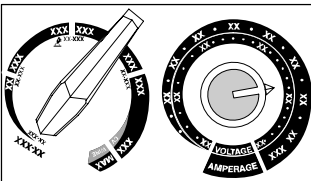

SOFTER ARC
A softer arc condition can be achieved by selecting the **lowest usable range** for the electrode with a **higher fine amperage** setting preferably above 50%. This improves 6010 for uphill pipe welding by reducing Arc outages/Popouts and reduces spatter with 7018.

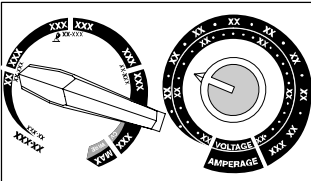

STIFFER ARC
A stiffer arc condition can be achieved by selecting the **highest usable range** for the electrode with a **lower fine amperage** setting preferably below 50%. This improves 6010 for downhill stick welding and 7018 for out of position welding by increasing dig.

☞ Set weld controls as shown to achieve softer or stiffer arc conditions for different applications.

SECTION 7 – OPERATING WELDING GENERATOR – CC/CV MODELS

7-1. Front Panel Controls For CC/CV Models (See Section 7-2)

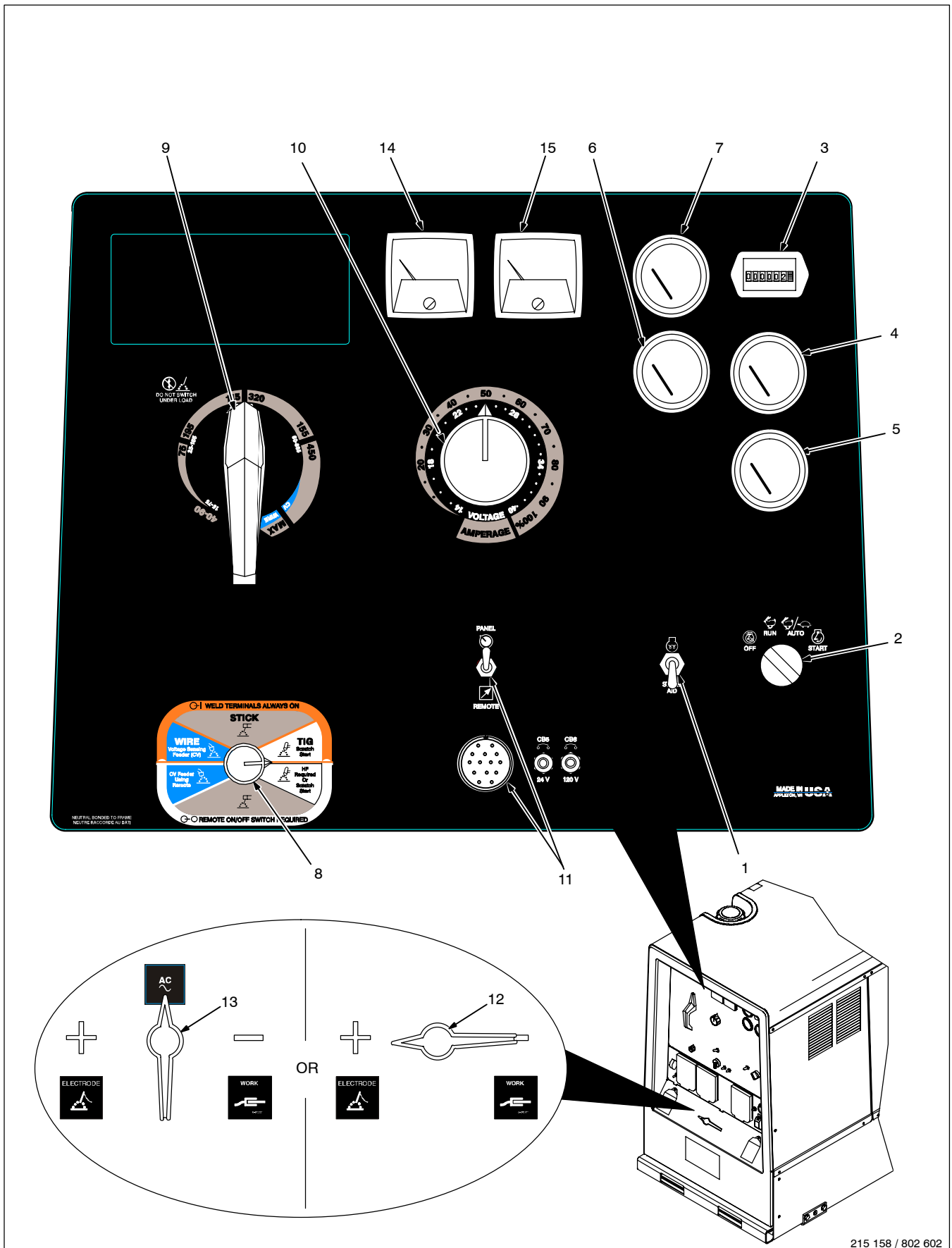

7-2. Description Of Front Panel Controls For CC/CV Models (See Section 7-1)

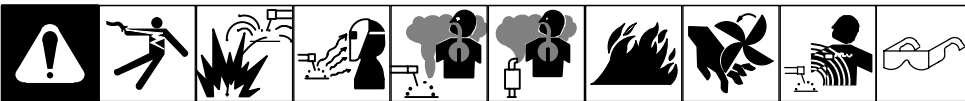

Engine Starting Controls

1 Starting Aid Switch

Use switch to energize starting aid for cold weather starting (see starting instructions following).

2 Engine Control Switch

Use switch to start engine, select engine speed (if unit has auto idle option), and stop engine.

In Run position, engine runs at weld/power speed. In Auto position (optional), engine runs at idle speed at no load and weld speed with load applied.

To Start:

▲ **Do not use ether. Using ether voids warranty.**

☞ *If engine does not start, let engine come to a complete stop before attempting restart.*

Above 32° F (0° C): turn Engine Control switch to Start. Release Engine Control switch when engine starts.

Below 32° F (0° C): push Starting Aid switch up for 60 seconds. While still holding Starting Aid switch, turn Engine Control switch to Start. Release Engine Control switch and Starting Aid switch when engine starts.

To Stop: turn Engine Control switch to Off position.

Engine Gauges And Meters

3 Engine Hour Meter

Use hour meter to monitor engine run time to help schedule maintenance.

4 Fuel Gauge

Use gauge to check fuel level.

To check fuel level when engine is not running, turn Engine Control switch to Run position

5 Battery Voltmeter (Optional)

Use gauge to check battery voltage and moni-

tor the engine charging system. The meter should read about 14 volts dc when the engine is running, and about 12 volts dc when the engine is stopped.

6 Engine Temperature Gauge

Normal temperature is 180 - 203° F (82 - 95° C). Engine stops if temperature exceeds 220° F (104° C).

7 Engine Oil Pressure Gauge

Normal pressure is 30 - 60 psi (207 - 414 kPa). Engine stops if pressure is below 10 psi (69 kPa).

Weld Controls

8 Process/Contactor Switch

See Section 7-3 for Process/Contactor switch information.

9 Ampere Range Switch

▲ **Do not switch under load.**

Use switch to select weld amperage range.

Use the lowest four ranges for Stick and TIG welding. Read the upper set of numbers at each range for Stick welding and the lower set at each range for TIG welding.

Use the highest range for MIG welding and for cutting and gouging (CAC-A).

For most welding applications, use lowest amperage range possible to help prevent arc outages.

10 Voltage/Amperage Adjust Control

With Process/Contactor switch in any Stick or TIG setting, use control to adjust amperage within range selected by Ampere Range switch. With Process/Contactor switch in any MIG position, use control to adjust voltage. With Voltage/Amperage Adjust Switch in Remote position, control limits the remote amperage in TIG mode, but has no effect in Stick and MIG modes.

Weld output would be about 218 A DC with controls set as shown (50% of 115 to 320 A).

☞ *The numbers around the control are for reference only and do not represent an actual percentage value.*

11 Voltage/Amperage Adjust Switch And Remote 14 Receptacle

Use switch to select front panel or remote voltage/amperage control. For remote control, place switch in Remote position and connect remote control to Remote 14 receptacle RC14 (see Sections 5-11 and 7-4).

12 Polarity Switch (Optional)

▲ **Do not switch under load.**

Use Polarity switch to change weld output. Select either DC Electrode Positive (DCEP) or DC Electrode Negative (DCEN).

13 Polarity/AC Switch (Optional)

▲ **Electric shock can kill.**

▲ **Do not use AC output in damp areas, if movement is confined, or if there is a danger of falling.**

▲ **Use AC output ONLY if required for the welding process. If AC output is required, use remote output control if present on unit.**

▲ **Do not switch under load.**

Use Polarity/AC switch to select AC or DC weld output and DC weld output polarity. For Direct Current Electrode Negative (DCEN), turn switch to - (Negative) position. For Direct Current Electrode Positive (DCEP), turn switch to + (Positive) position. For weld processes that require alternating current (AC), use AC position.

Weld Meters

14 AC/DC Voltmeter (Optional)

Voltmeter displays voltage at the weld output terminals, but not necessarily the welding arc due to resistance of cable and connections.

15 AC/DC Ammeter (Optional)

Ammeter displays amperage output of the unit.

7-3. Process/Contactor Switch On CC/CV Models

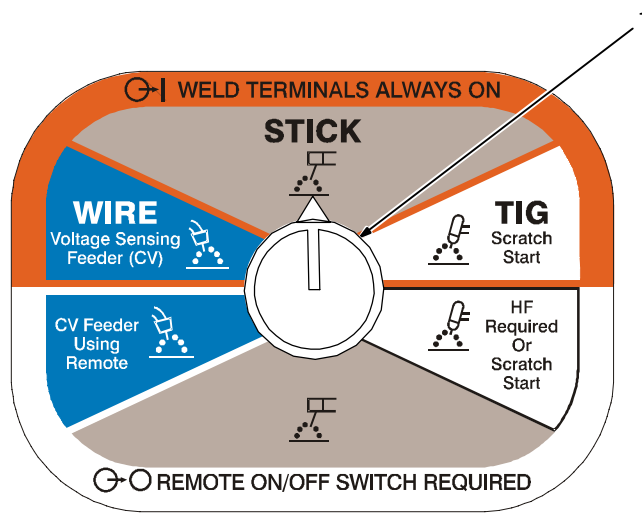

1 Process/Contactor Switch

▲ **Weld output terminals are energized when Process/Contactor switch is in an Weld Terminals Always On position and the engine is running.**

▲ **DC voltage is still present at the weld terminals when Process/Contactor switch is in the Remote On/Off Switch Required – Stick position and the engine is running.**

Use switch to select weld process and weld output on/off control (see table below and Section 7-4).

Place switch in Remote On/Off Switch Required positions to turn weld output on and off with a device connected to the remote 14 receptacle.

Place switch in Weld Terminals Always On positions for weld output to be on whenever the engine is running.

Use Stick position for air carbon arc (CAC-A) cutting and gouging.

When switch is in a Stick position, the arc drive (dig) circuit provides additional amperage during low voltage (short arc length conditions) to prevent “sticking” electrodes.

The arc drive (dig) circuit is disabled when switch is in MIG or TIG positions.

☞ *Place switch in Weld Terminals Always On - Stick position when using optional three-phase generator (see Section 8-2).*

☞ *The engine auto idle option does not work in the Remote On/Off Switch Required-TIG mode.*

Process/Contactor Switch Settings

Switch Setting	Process	Output On/Off Control	Engine Auto Idle (Optional)
Remote On/Off Switch Required – TIG, HF Required Or Scratch Start TIG	GTAW With HF Unit, Pulsing Device, Or Remote Control	At Remote 14 Receptacle	Not Active
Remote On/Off Switch Required – Stick	Stick (SMAW) With Remote On/Off	At Remote 14 Receptacle	Active
Remote On/Off Switch Required – CV Feeder Using Remote	MIG (GMAW)	At Remote 14 Receptacle	Active
Weld Terminals Always On – Wire	MIG (GMAW)	Electrode Hot	Active
Weld Terminals Always On – Stick	Stick (SMAW), Air Carbon Arc (CAC-A) Cutting And Gouging	Electrode Hot	Active
Weld Terminals Always On – TIG, Scratch Start	TIG Scratch Start (GTAW)	Electrode Hot	Active

7-4. Remote Voltage/Amperage Control On CC/CV Models (Optional)



1 Remote 14 Receptacle RC14
Connect optional remote control to RC14 (see Section 5-11).

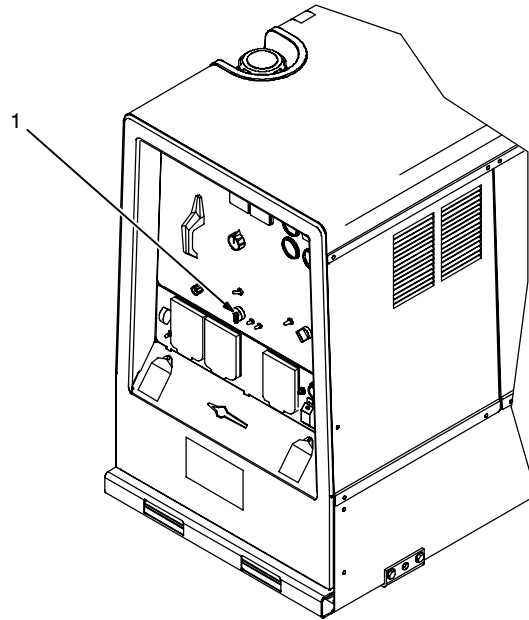

Example: Combination Remote Amperage Control (Stick)

In Example:
Process = Stick (Using Remote On/Off)
Range = 115 to 320 A DC
Min = 115 A DC
Max = 320 A DC

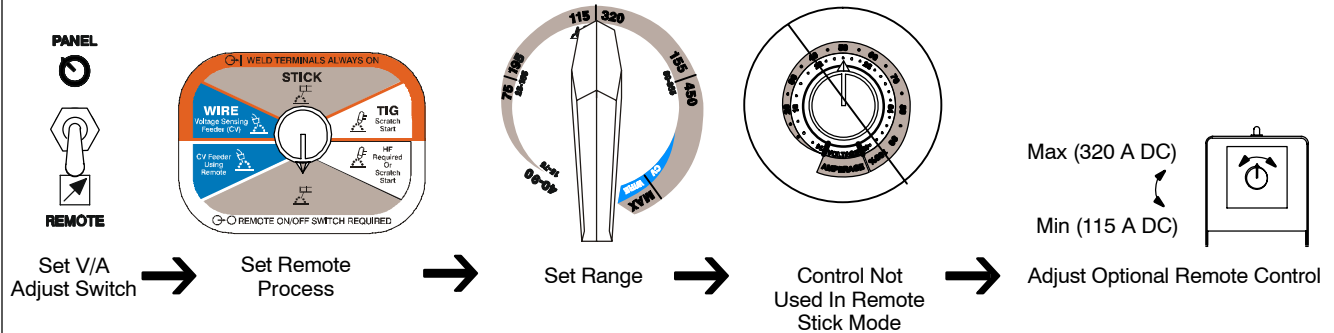

Example: Combination Remote Amperage Control (TIG)

In Example:
Process = TIG (Using Remote On/Off)
Range = 35 to 250 A DC
Percentage Of Range = 50%
Min = 35 A DC
Max = About 143 A DC (50% of 35 to 250)

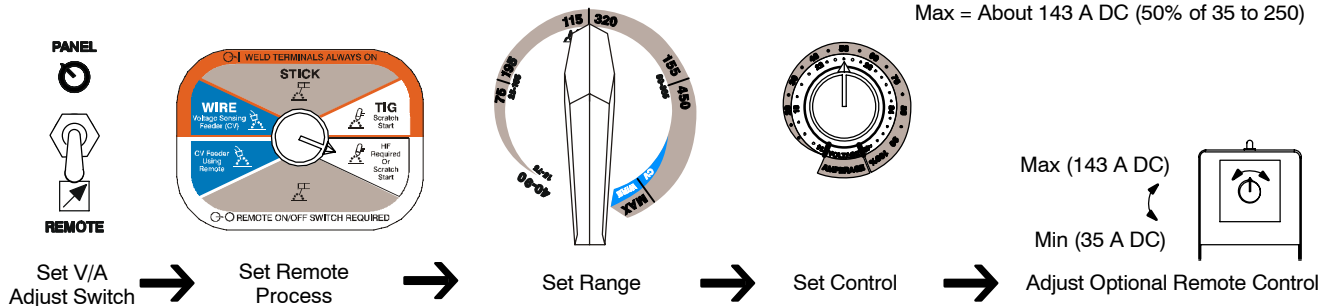

SECTION 8 – OPERATING AUXILIARY EQUIPMENT

8-1. 120 Volt And 240 Volt Receptacles

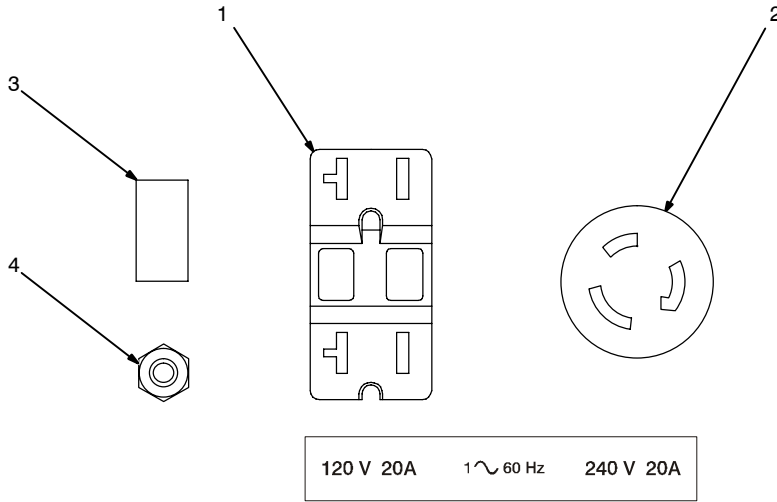

- 1 120 V 20 A AC GFCI Receptacle GFCI1
- 2 240 V 30 A AC Twistlock Receptacle RC1

Receptacles supply 60 Hz single-phase power at weld/power speed.

If a ground fault is detected, GFCI Reset button pops out and receptacle does not work. Check for faulty tools plugged in receptacle. Press button to reset GFCI1.

 *At least once a month, run engine at weld/power speed and press test button to verify GFCI is working properly.*

- 3 Circuit Breaker CB1
- 4 Circuit Breaker CB2

CB1 protects RC1 and the generator winding from overload. If CB1 opens, RC1 and GFCI1 do not work. Place switch in On position to reset breaker.

CB2 protects GFCI1 from overload. If CB2 opens, GFCI1 does not work. Press button to reset breaker.

 *If a circuit breaker continues to open, contact Factory Authorized Service Agent.*

 *Generator power is not affected by weld output.*

Maximum output is 2.4 kVA/kW from GFCI1 and 4 kVA/kW from RC1. Maximum output from all receptacles is 4 kVA/kW.

EXAMPLE: If 13 A is drawn from RC1, only 7 A is available at GFCI1:

$$(240 \text{ V} \times 13 \text{ A}) + (120 \text{ V} \times 7 \text{ A}) = 4.0 \text{ kVA/kW}$$

8-2. Connecting To Optional Three-Phase Generator (CC/CV Models Only)

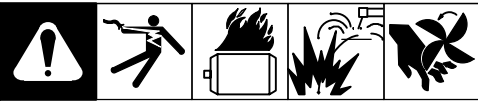

Single-Phase Power Connection

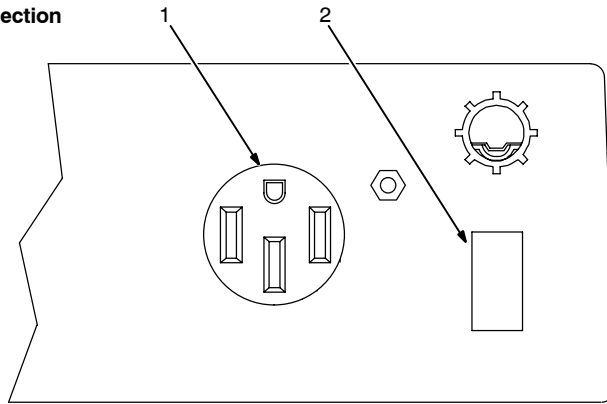

☞ Place Process/Contactor switch in Weld Terminals Always On - Stick position when using three-phase generator (see Section 7-3).

Single-Phase Generator Power

- 1 120/240 V 50 A Receptacle RC5

RC5 is connected to the optional three-phase generator and supplies 60 Hz single-phase power at weld/power speed. Maximum output from RC5 is 12 kVA/kW. Power available at RC5 is reduced when welding.

- 2 Circuit Breaker CB7

Circuit breaker CB7 protects single-phase receptacle RC5 and the load wires from overload. If CB7 opens, all generator output stops and the receptacle does not work.

Three-Phase Power Connection

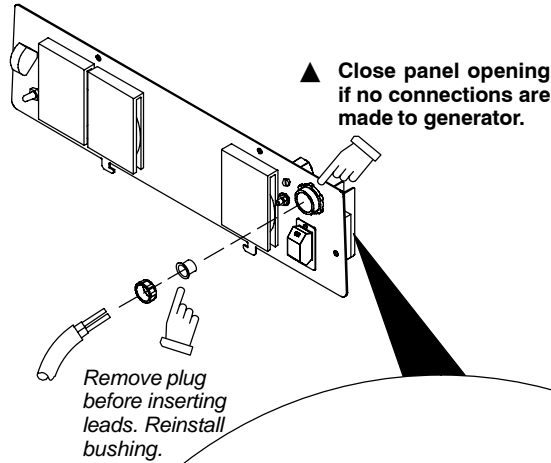

AC ~ Output	Single Phase 1 ~	Three Phase 3 ~
Volts	120/240	240
Amps	50	36
KVA/KW	12	15
Frequency	60 Hz	
Engine Speed	1850 RPM	

Lead 42 connects to GROUND stud on front of unit.
Jumper 42 is connected to 90 at factory.

Three-Phase Generator Power

▲ Stop engine.

▲ Power and weld outputs are live at the same time. Disconnect or insulate unused cables.

☞ Have qualified person install according to circuit diagram and Generator Power Guidelines (see Section 12).

Remove generator power panel mounting screws. Tilt panel forward.

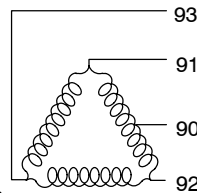

- 3 Lead 93
- 4 Lead 92
- 5 Lead 91
- 6 Lead 42 (Circuit Grounding Lead)
- 7 Lead 90 (Neutral)
- 8 Isolated Neutral Terminal
- 9 Jumper Lead 42
- 10 Grounding Terminal

Jumper 42 is connected to lead 90 at factory. Jumper 42 may be disconnected from neutral to meet applicable electrical codes.

Lead 42 connects to front panel Ground stud.

- 11 User-Supplied Leads
- 12 Circuit Breaker CB7 User Terminals

Connect user-supplied leads to terminals on CB7 and to the isolated neutral terminal and grounding terminal as necessary.

☞ Circuit breaker CB7 protects single-phase receptacle RC5 and the load wires from overload. If CB7 opens, all generator output stops and the receptacle does not work.

Reinstall generator power panel.

Tools Needed:

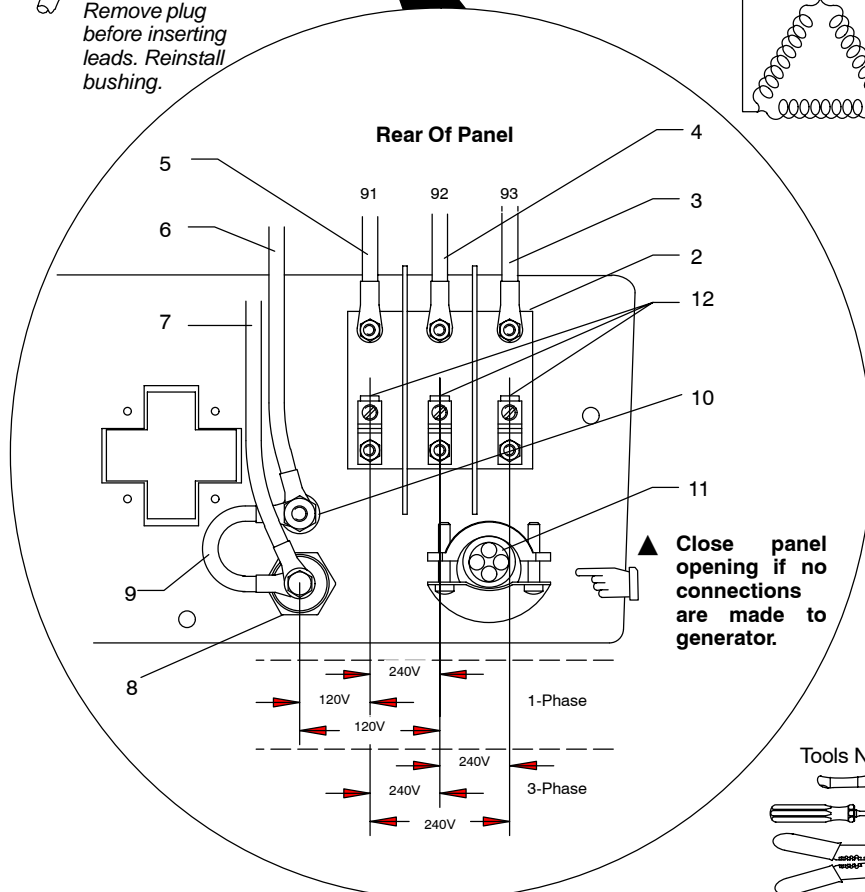
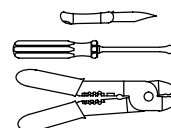

8-3. Optional Generator Power Receptacles



European Receptacle

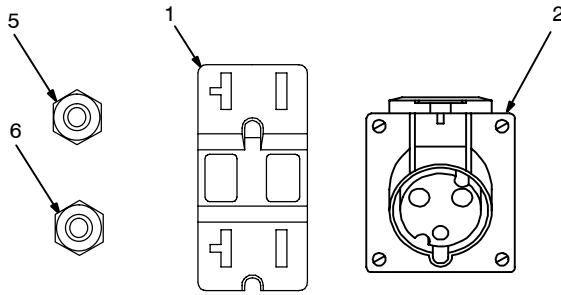

120 V 20A 1~ 60 Hz 240 V 15 A

- 1 120 V 20 A AC GFCI Receptacle GFCI1
- 2 240 V 16 A AC European Receptacle RC1
- 3 240 V 15 A AC Australian Receptacle RC1
- 4 240 V 15 A AC South African Receptacle RC1

Receptacles supply 60 Hz single-phase power at weld/power speed.

If a ground fault is detected, the GFCI Reset button pops out and the receptacle does not work. Check for faulty tools plugged in receptacle. Press button to reset GFCI1.

☞ *At least once a month, run engine at weld/power speed and press test button to verify GFCI is working properly.*

Australian Receptacle

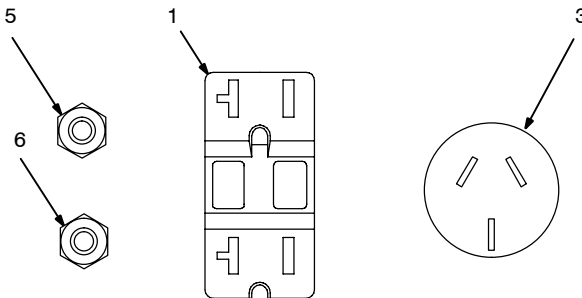

120 V 20A 1~ 60 Hz 240 V 15 A

- 5 Circuit Breaker CB2
- 6 Circuit Breaker CB3

CB2 protects GFCI1 from overload. If CB2 opens, GFCI1 does not work. Press button to reset breaker.

CB3 protects RC1 from overload. If CB3 opens, RC1 does not work. Press button to reset breaker.

☞ *If a circuit breaker continues to open, contact Factory Authorized Service Agent.*

☞ *Generator power is not affected by weld output.*

South African Receptacle

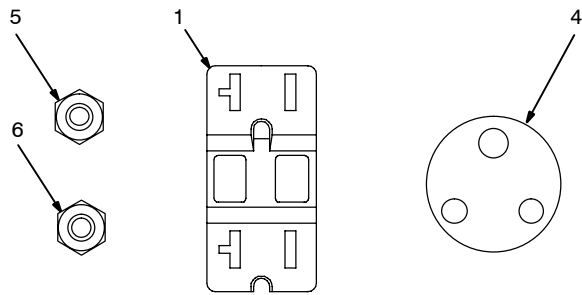

120 V 20A 1~ 60 Hz 240 V 15 A

Maximum output is 2.4 kVA/kW from GFCI1 and 4 kVA/kW from RC1. Maximum output from all receptacles is 4 kVA/kW.

EXAMPLE: If 13 A is drawn from RC1, only 7 A is available at GFCI1:

$$(240 \text{ V} \times 13 \text{ A}) + (120 \text{ V} \times 7 \text{ A}) = 4.0 \text{ kVA/kW}$$

SECTION 9 – MAINTENANCE & TROUBLESHOOTING

9-1. Maintenance Label

DEUTZ F4L2011/F3L2011 AND F3L912 DIESEL ENGINES



12 V
BCI 24
650 A @ -18C (0F)



1250 RPM



1850 RPM

8 h std.



DIESEL
93.7 L (24.75 gal)
DIN 51 601
BS 2869: A1, A2
ASTM D 975-81: 1-D, 2-D
VW-F 800C: DF-A, DF-1, DF-2
S < = .5%

50 h std.

(Optional)
MILLER 192 939
Donaldson P822769
WIX 46490

MILLER 192 938
Donaldson P822768
WIX 46489

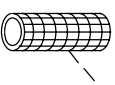
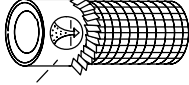



250 h std.

F3L2011 MILLER 216 959
Deutz 117-9564
Gates AX44

F4L2011 MILLER 067 266
Deutz 117-9565
Gates 7435

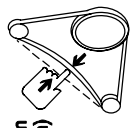
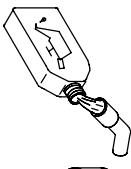
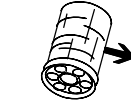
F3L912 MILLER 066 271
Deutz 223-5256
Gates 7580

1000 h std.

API: CD/CE/CF-4

F3L2011 F4L2011 F3L912
8.2 L 8.5 L 8.5 L
(6.7 qt) (9 qt) (9 qt)

F3L912 MILLER 067 265
Deutz 117-4416
Fram PH46

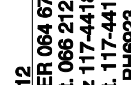
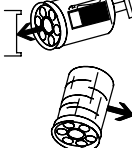

F3L912 MILLER 064 677 1.5L
Opt. 066 212 1L
Deutz 117-4418 1.5L
Opt. 117-4417 1L
Fram PH6923

250 h std.

1. MILLER 192 744
Donaldson P550687
Fram PT145A

20° C (72° F)
F3L912
In.- 0.3 mm
(0.012 in)
ex.- 0.5 mm
(0.020 in)

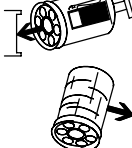

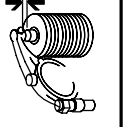



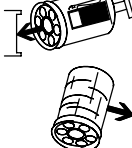

1000 h std.

1. MILLER 192 744
Donaldson P550687
Fram PT145A

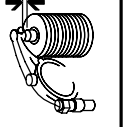
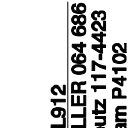
2. F3/4L2011
MILLER 066 217
Deutz 117-4696
Donaldson P550845

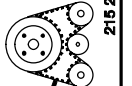
20° C (72° F)
F3/4L2011
In.- 0.15 mm
(0.006 in)
ex.- 0.15 mm
(0.006 in)









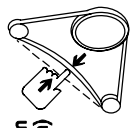
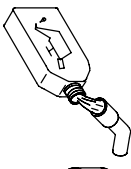
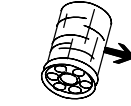
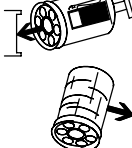

250 h std.

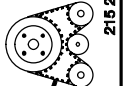
F3L2011 MILLER 216 959
Deutz 117-9564
Gates AX44

F4L2011 MILLER 067 266
Deutz 117-9565
Gates 7435

F3L912 MILLER 066 271
Deutz 223-5256
Gates 7580



1000 h std.

API: CD/CE/CF-4

F3L2011 F4L2011 F3L912
8.2 L 8.5 L 8.5 L
(6.7 qt) (9 qt) (9 qt)

F3L912 MILLER 067 265
Deutz 117-4416
Fram PH46

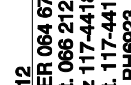
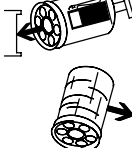
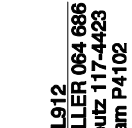

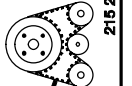

F3L912 MILLER 064 677 1.5L
Opt. 066 212 1L
Deutz 117-4418 1.5L
Opt. 117-4417 1L
Fram PH6923

250 h std.

1. MILLER 192 744
Donaldson P550687
Fram PT145A

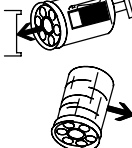
20° C (72° F)
F3L912
In.- 0.3 mm
(0.012 in)
ex.- 0.5 mm
(0.020 in)

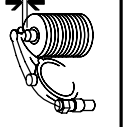
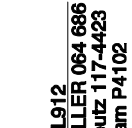

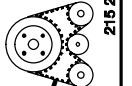







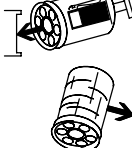

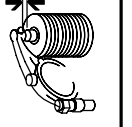
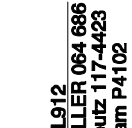
1000 h std.

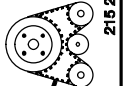
1. MILLER 192 744
Donaldson P550687
Fram PT145A

2. F3/4L2011
MILLER 066 217
Deutz 117-4696
Donaldson P550845

20° C (72° F)
F3/4L2011
In.- 0.15 mm
(0.006 in)
ex.- 0.15 mm
(0.006 in)









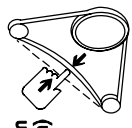
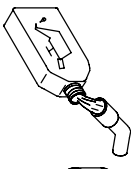
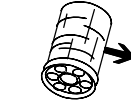
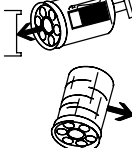

250 h std.

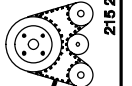
F3L2011 MILLER 216 959
Deutz 117-9564
Gates AX44

F4L2011 MILLER 067 266
Deutz 117-9565
Gates 7435

F3L912 MILLER 066 271
Deutz 223-5256
Gates 7580



1000 h std.

API: CD/CE/CF-4

F3L2011 F4L2011 F3L912
8.2 L 8.5 L 8.5 L
(6.7 qt) (9 qt) (9 qt)

F3L912 MILLER 067 265
Deutz 117-4416
Fram PH46

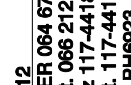
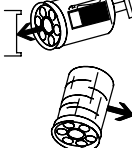
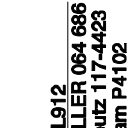

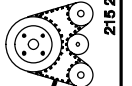

F3L912 MILLER 064 677 1.5L
Opt. 066 212 1L
Deutz 117-4418 1.5L
Opt. 117-4417 1L
Fram PH6923

250 h std.

1. MILLER 192 744
Donaldson P550687
Fram PT145A

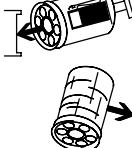
20° C (72° F)
F3L912
In.- 0.3 mm
(0.012 in)
ex.- 0.5 mm
(0.020 in)

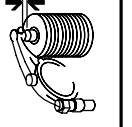
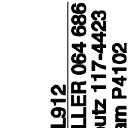

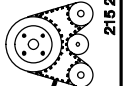







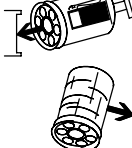

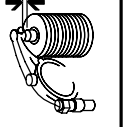
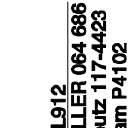
1000 h std.

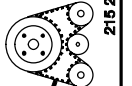
1. MILLER 192 744
Donaldson P550687
Fram PT145A

2. F3/4L2011
MILLER 066 217
Deutz 117-4696
Donaldson P550845

20° C (72° F)
F3/4L2011
In.- 0.15 mm
(0.006 in)
ex.- 0.15 mm
(0.006 in)









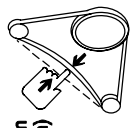
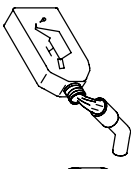
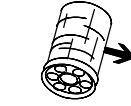
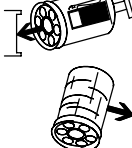

250 h std.

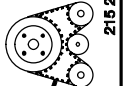
F3L2011 MILLER 216 959
Deutz 117-9564
Gates AX44

F4L2011 MILLER 067 266
Deutz 117-9565
Gates 7435

F3L912 MILLER 066 271
Deutz 223-5256
Gates 7580



1000 h std.

API: CD/CE/CF-4

F3L2011 F4L2011 F3L912
8.2 L 8.5 L 8.5 L
(6.7 qt) (9 qt) (9 qt)

F3L912 MILLER 067 265
Deutz 117-4416
Fram PH46

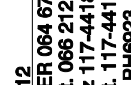
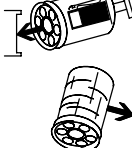
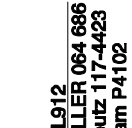

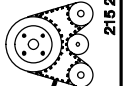

F3L912 MILLER 064 677 1.5L
Opt. 066 212 1L
Deutz 117-4418 1.5L
Opt. 117-4417 1L
Fram PH6923

250 h std.

1. MILLER 192 744
Donaldson P550687
Fram PT145A

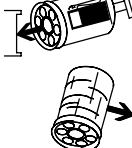
20° C (72° F)
F3L912
In.- 0.3 mm
(0.012 in)
ex.- 0.5 mm
(0.020 in)

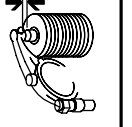
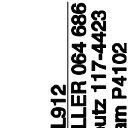

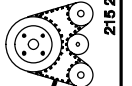







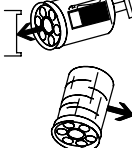

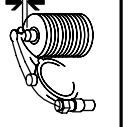
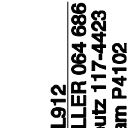
1000 h std.

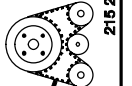
1. MILLER 192 744
Donaldson P550687
Fram PT145A

2. F3/4L2011
MILLER 066 217
Deutz 117-4696
Donaldson P550845

20° C (72° F)
F3/4L2011
In.- 0.15 mm
(0.006 in)
ex.- 0.15 mm
(0.006 in)









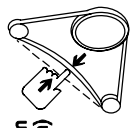
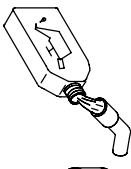
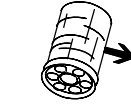
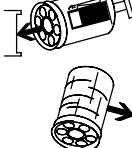

250 h std.

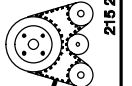
F3L2011 MILLER 216 959
Deutz 117-9564
Gates AX44

F4L2011 MILLER 067 266
Deutz 117-9565
Gates 7435

F3L912 MILLER 066 271
Deutz 223-5256
Gates 7580



1000 h std.

API: CD/CE/CF-4

F3L2011 F4L2011 F3L912
8.2 L 8.5 L 8.5 L
(6.7 qt) (9 qt) (9 qt)

F3L912 MILLER 067 265
Deutz 117-4416
Fram PH46

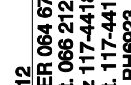
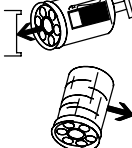
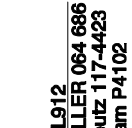

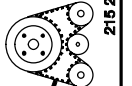

F3L912 MILLER 064 677 1.5L
Opt. 066 212 1L
Deutz 117-4418 1.5L
Opt. 117-4417 1L
Fram PH6923

250 h std.

1. MILLER 192 744
Donaldson P550687
Fram PT145A

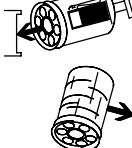
20° C (72° F)
F3L912
In.- 0.3 mm
(0.012 in)
ex.- 0.5 mm
(0.020 in)

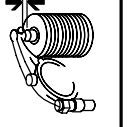
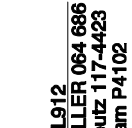

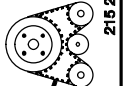







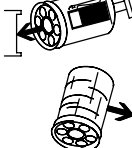

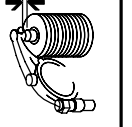
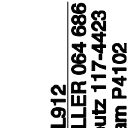
1000 h std.

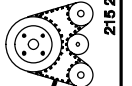
1. MILLER 192 744
Donaldson P550687
Fram PT145A

2. F3/4L2011
MILLER 066 217
Deutz 117-4696
Donaldson P550845

20° C (72° F)
F3/4L2011
In.- 0.15 mm
(0.006 in)
ex.- 0.15 mm
(0.006 in)









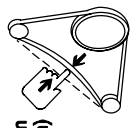
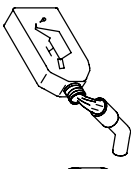
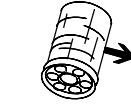
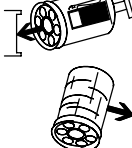

250 h std.

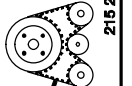
F3L2011 MILLER 216 959
Deutz 117-9564
Gates AX44

F4L2011 MILLER 067 266
Deutz 117-9565
Gates 7435

F3L912 MILLER 066 271
Deutz 223-5256
Gates 7580



1000 h std.

API: CD/CE/CF-4

F3L2011 F4L2011 F3L912
8.2 L 8.5 L 8.5 L
(6.7 qt) (9 qt) (9 qt)

F3L912 MILLER 067 265
Deutz 117-4416
Fram PH46

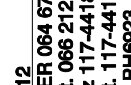
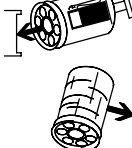
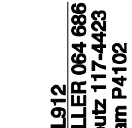

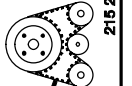

F3L912 MILLER 064 677 1.5L
Opt. 066 212 1L
Deutz 117-4418 1.5L
Opt. 117-4417 1L
Fram PH6923

250 h std.

1. MILLER 192 744
Donaldson P550687
Fram PT145A

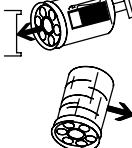
20° C (72° F)
F3L912
In.- 0.3 mm
(0.012 in)
ex.- 0.5 mm
(0.020 in)

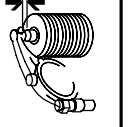
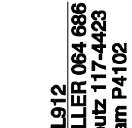

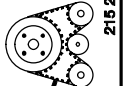







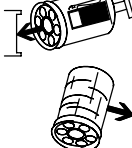

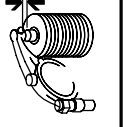
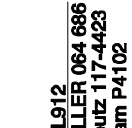
1000 h std.

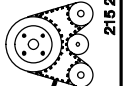
1. MILLER 192 744
Donaldson P550687
Fram PT145A

2. F3/4L2011
MILLER 066 217
Deutz 117-4696
Donaldson P550845

20° C (72° F)
F3/4L2011
In.- 0.15 mm
(0.006 in)
ex.- 0.15 mm
(0.006 in)









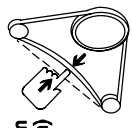
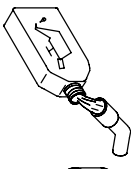
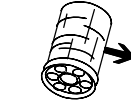
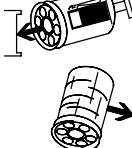

250 h std.

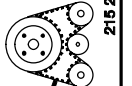
F3L2011 MILLER 216 959
Deutz 117-9564
Gates AX44

F4L2011 MILLER 067 266
Deutz 117-9565
Gates 7435

F3L912 MILLER 066 271
Deutz 223-5256
Gates 7580



1000 h std.

API: CD/CE/CF-4

F3L2011 F4L2011 F3L912
8.2 L 8.5 L 8.5 L
(6.7 qt) (9 qt) (9 qt)

F3L912 MILLER 067 265
Deutz 117-4416
Fram PH46

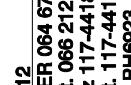
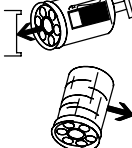
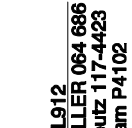

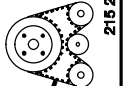

F3L912 MILLER 064 677 1.5L
Opt. 066 212 1L
Deutz 117-4418 1.5L
Opt. 117-4417 1L
Fram PH6923

250 h std.

1. MILLER 192 744
Donaldson P550687
Fram PT145A

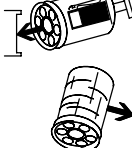
20° C (72° F)
F3L912
In.- 0.3 mm
(0.012 in)
ex.- 0.5 mm
(0.020 in)

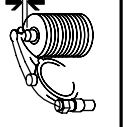
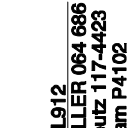

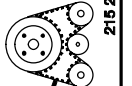







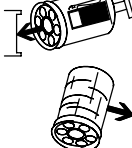

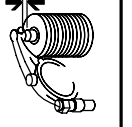
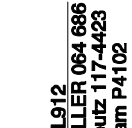
1000 h std.

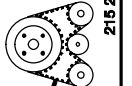
1. MILLER 192 744
Donaldson P550687
Fram PT145A

2. F3/4L2011
MILLER 066 217
Deutz 117-4696
Donaldson P550845

20° C (72° F)
F3/4L2011
In.- 0.15 mm
(0.006 in)
ex.- 0.15 mm
(0.006 in)









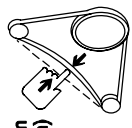
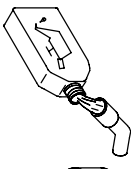
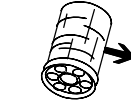
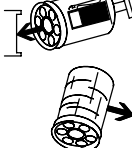

250 h std.

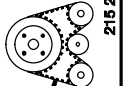
F3L2011 MILLER 216 959
Deutz 117-9564
Gates AX44

F4L2011 MILLER 067 266
Deutz 117-9565
Gates 7435

F3L912 MILLER 066 271
Deutz 223-5256
Gates 7580



1000 h std.

API: CD/CE/CF-4

F3L2011 F4L2011 F3L912
8.2 L 8.5 L 8.5 L
(6.7 qt) (9 qt) (9 qt)

F3L912 MILLER 067 265
Deutz 117-4416
Fram PH46

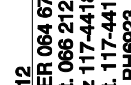
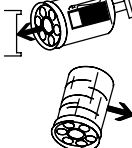
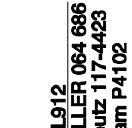

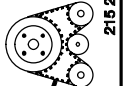
F3L912 MILLER 064 677 1.5L
Opt. 066 212 1L
Deutz 117-4418 1.5L
Opt. 117-4417 1L
Fram PH6923

250 h std.





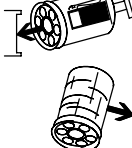

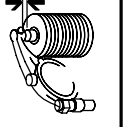



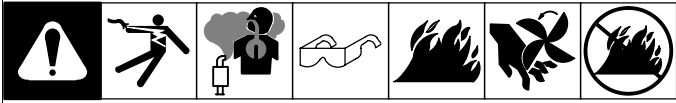



1. MILLER 192 744
Donaldson P550687
Fram PT145A

20° C (72° F)
F3L912
In.- 0.3 mm
(0.012 in)
ex.- 0.5 mm
(0.020 in)



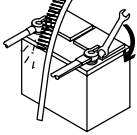
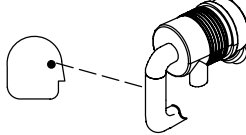

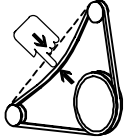
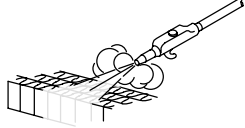
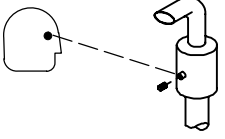
9-2. Routine Maintenance

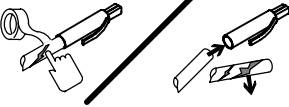
Note  Follow the storage procedure in the engine owner's manual if the unit will not be used for an extended period.

		 <p>Recycle engine fluids.</p>	<p>▲ Stop engine before maintaining.</p> <p> See Engine Manual and Maintenance Label for important start-up, service, and storage information. Service engine more often if used in severe conditions.</p> <p>* To be done by Factory Authorized Service Agent.</p>
 Every 8 h			
 <p>Wipe Up Spills.</p>	 <p>Check Fluid Levels. See Section 5-7.</p>	<p>FUEL WATER</p>  <p>Drain Water From Fuel System. See Section 9-6.</p>	
 Every 50 h			
 <p>Clean Air Filter. See Section 9-3.</p>	 <p>Clean And Tighten Weld Terminals.</p>		
 Every 100 h			
 <p>Clean And Tighten Battery Connections.</p>	 <p>Check air cleaner hoses for cracks and loose clamps.</p>		
 Every 250 h			
 <p>Replace Unreadable Labels.</p>	 <p>1/2 in. (13 mm)</p> <p>Check Belt Tension.</p>		
 <p>Clean Cooling System.</p>	 <p>Check And Clean Spark Arrestor. See Section 9-4.</p>		
 Every 500 h			
 <p>Repair Or Replace Cracked Cables.</p>			

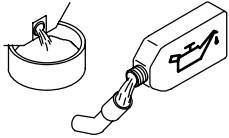
 **Every 1000 h**



Change Oil. See Section 9-6.

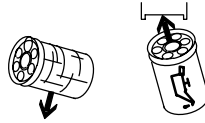

Change Oil Filter. See Section 9-6. Service more often in dirty conditions.

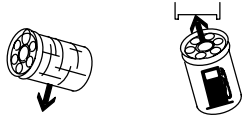

Change Fuel Filters. See Section 9-6.

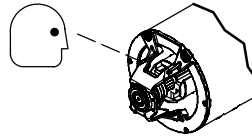

Service Welding Generator Brushes And Slip Rings. Service More Often In Dirty Conditions.*

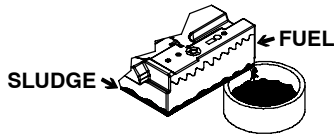

Drain Sludge From Fuel Tank. See Section 9-6.

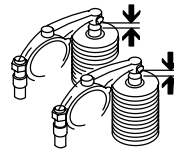

Check Valve Clearance.*

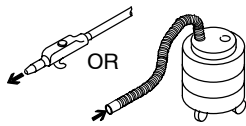

Blow Out Or Vacuum Inside. During Heavy Service, Clean Monthly.

 **Every 3000 h**

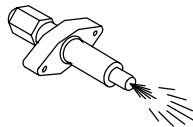

Clean/Set Injectors.*

 **Every 4500 h / 5 Years**

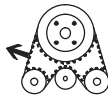

Replace Engine Timing Belt.

9-3. Servicing Air Cleaner

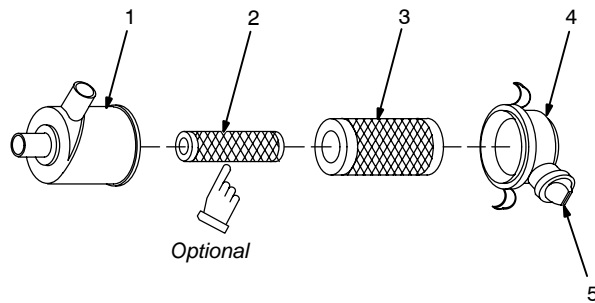
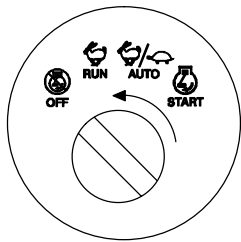

▲ Stop engine.

▲ Do not run engine without air cleaner or with dirty element. Engine damage caused by using a damaged element is not covered by the warranty.

☞ The air cleaner primary element can be cleaned but the dirt holding capacity of the filter is reduced with each cleaning. The chance of dirt reaching the clean side of the filter while cleaning and the possibility of filter damage makes cleaning a risk. Consider the risk of unwarrantable equipment damage when determining whether to clean or replace the primary element.

If you decide to clean the primary element, we strongly recommend installing an optional safety element to provide additional engine protection. **Never clean a safety element.** Replace the safety element after servicing the primary element three times.

Clean or replace primary element if dirty (see note above before cleaning). **Replace** primary element if damaged. Replace primary element yearly or after six cleanings.

- 1 Housing
- 2 Safety Element (Optional)
- 3 Primary Element
- 4 Dust Cap
- 5 Dust Ejector

To clean air filter:

Wipe off cap and housing. Remove cap and dump out dust. Remove element(s). Wipe dust from inside cap and housing with damp cloth. Reinstall safety element (if present). Reinstall cap.

▲ Do not clean housing with air hose.

Clean primary element with compressed air only.

Air pressure must not exceed 100 psi (690 kPa). Use 1/8 in (3 mm) nozzle and keep nozzle at least 2 in (51 mm) from inside of element. Replace primary element if it has holes or damaged gaskets.

Reinstall primary element and cap (dust ejector down).

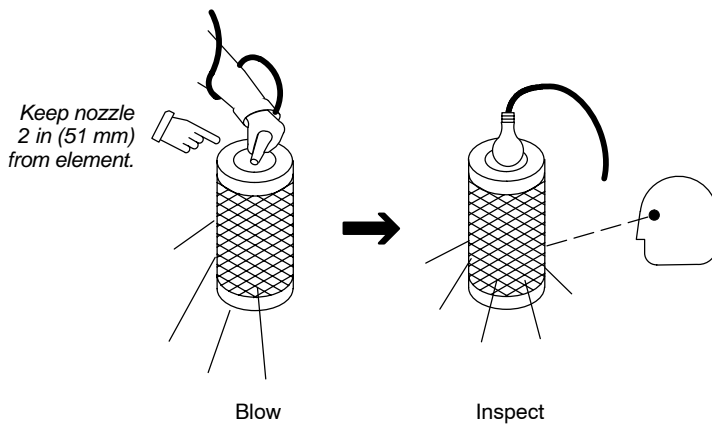

9-4. Inspecting And Cleaning Optional Spark Arrestor Muffler

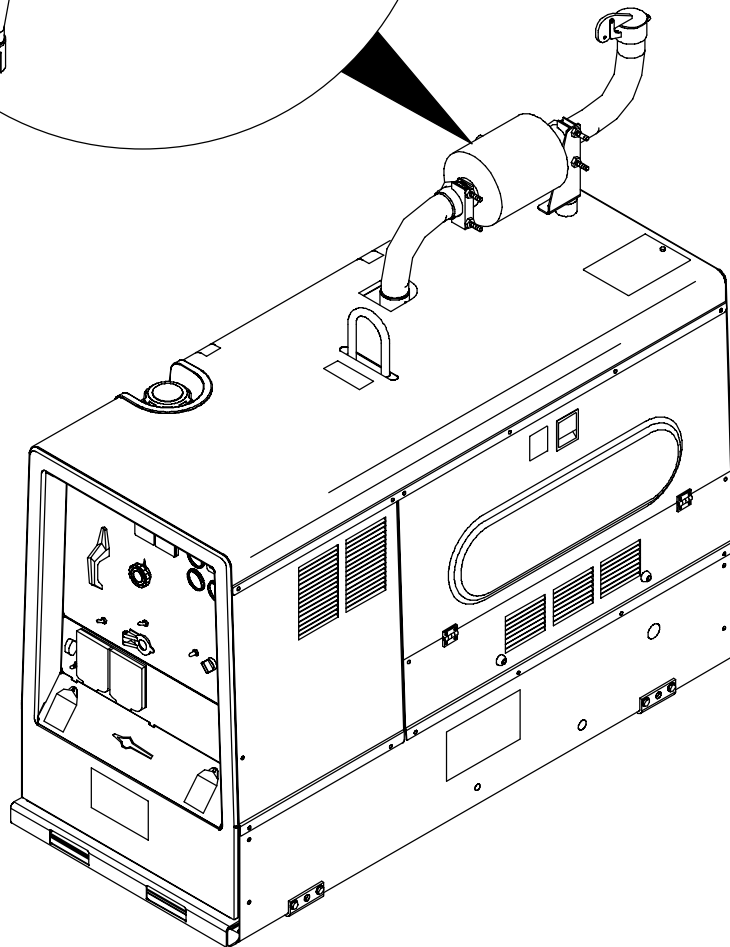
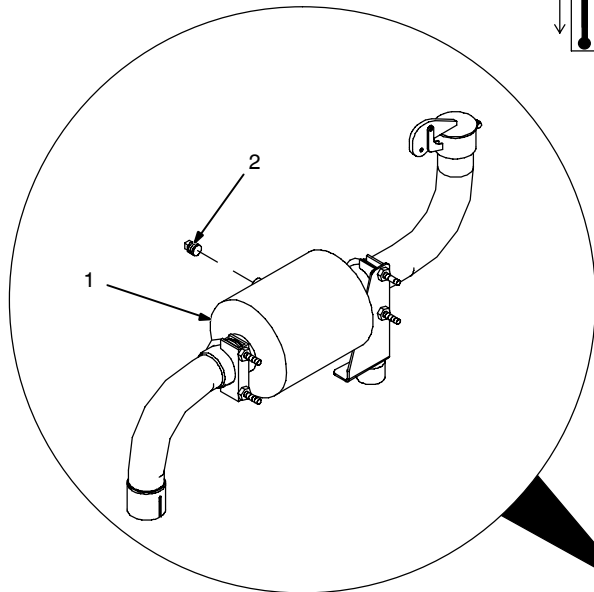
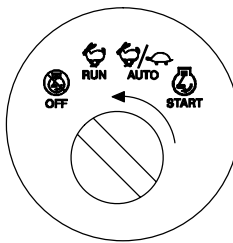

▲ Stop engine and let cool.

- 1 Spark Arrestor Muffler
- 2 Cleanout Plug

Remove plug and remove any dirt covering cleanout hole.

Start engine and run at idle speed to blow out cleanout hole. If nothing blows out of hole, briefly cover end of exhaust pipe with fireproof material.

▲ Stop engine and let cool.

Reinstall cleanout plug.

Tools Needed:

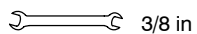

9-5. Adjusting Engine Speed

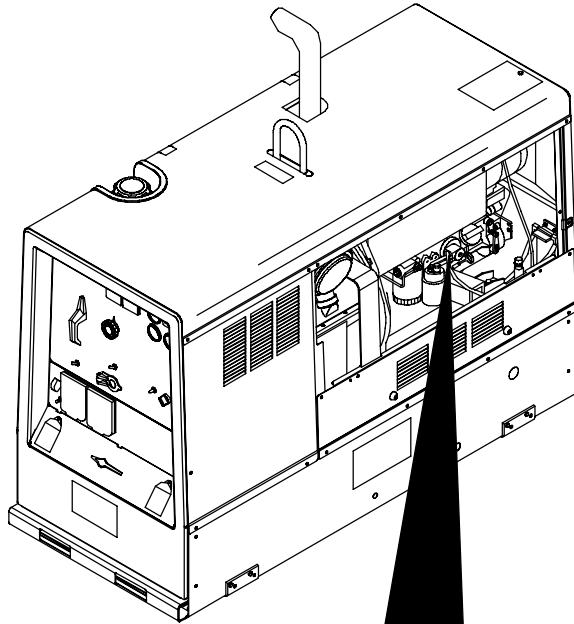
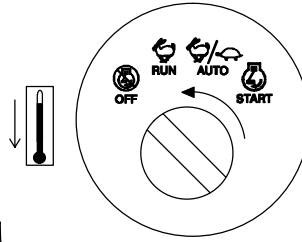

	1850 rpm Max. (61.6 Hz)
	1250 rpm (41.6 Hz)

Standard Models

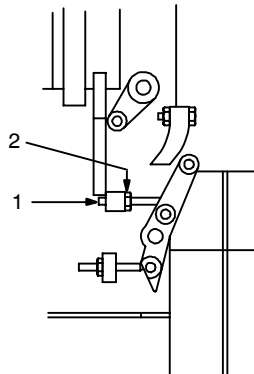

Models With Automatic Idle (Optional)

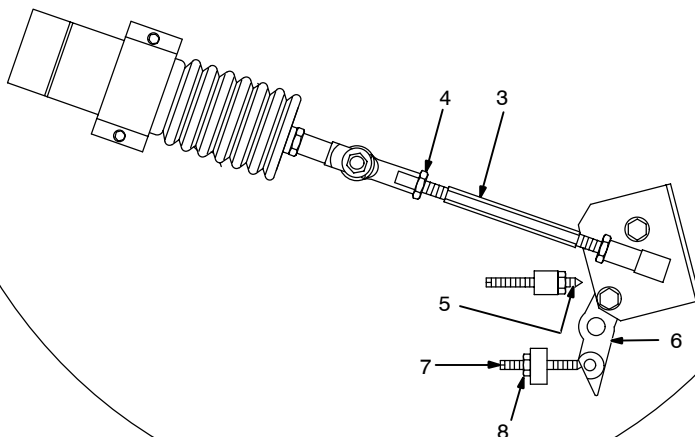

Tools Needed:



▲ Stop engine and let cool.

Engine speed is factory set and should not require adjustment. After tuning engine, check engine no load speed with a tachometer or frequency meter (see table for no load speeds). If necessary, adjust speed as follows:

Start engine and run until warm.

On CC Models, place Stick/TIG switch in Stick position.

On CC/CV models, turn Process/Contactor switch to Stick - Electrode Hot position.

Standard Models:

- 1 Engine Speed Adjustment Screw
- 2 Locking Nut

Loosen nut. Turn screw until engine runs at weld/power speed. Tighten nut.

Do not set engine speed higher than specified.

Models With Automatic Idle (Optional)

- 3 Throttle Rod
- 4 Locknut
- 5 Throttle Stop Screw
- 6 Throttle Lever

Loosen locknuts. Place engine control switch in Run/Idle position.

Turn throttle rod until engine runs at idle speed. Tighten locknuts.

▲ To prevent solenoid damage, be sure a 1/8 in (3 mm) gap exists between the throttle stop screw and throttle lever when the solenoid is held in the energized position.

- 7 Engine Speed Adjustment Screw
- 8 Locknut

Place engine control switch in Run position.

Loosen locknut. Turn screw until engine runs at weld/power speed. Tighten locknut.

Do not set engine speed higher than specified.

▲ Stop engine.

Close door.

9-6. Servicing Fuel And Lubrication Systems

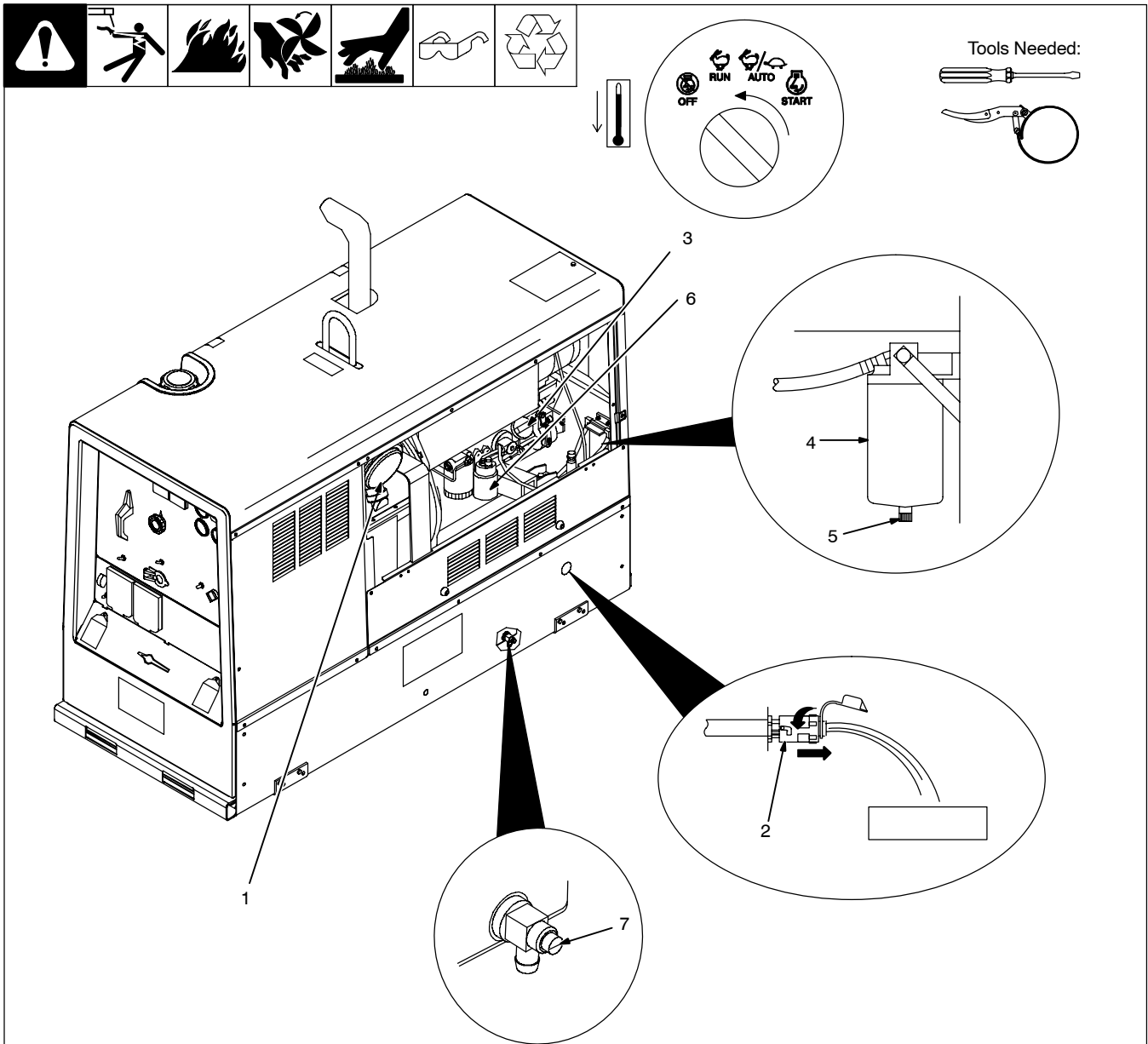

803 644 / Ref. 800 159

▲ **Stop engine and let cool.**

▲ **After servicing, start engine and check for fuel leaks. Stop engine, tighten connections as necessary, and wipe up spilled fuel.**

- 1 Oil Filter
- 2 Oil Drain Valve And Hose
- 3 Oil Fill Cap
- 4 Primary Fuel Filter (Fuel/Water Separator)
- 5 Petcock
- 6 Secondary Fuel Filter
- 7 Fuel Tank Sludge Drain Valve

To change oil and filter:

Route oil drain hose and valve through hole

in base. See engine manual and engine maintenance label for oil/filter change information.

To drain water from fuel system:

Open primary fuel filter petcock and drain water into metal container. Close petcock when water-free fuel flows.

To replace primary fuel filter:

Turn filter counterclockwise. Remove filter.

Apply thin coat of fuel to gasket on new filter. Fill filter with fuel. Install filter and turn clockwise. Bleed air from fuel system according to engine manual.

Inspect fuel line, and replace if cracked or worn.

To replace secondary fuel filter:

See engine manual.

Close doors.

To drain sludge from fuel tank:

▲ **Beware of fire. Do not smoke and keep sparks and flames away from drained fuel. Dispose of drained fuel in an environmentally-safe manner. Do not leave unit unattended while draining fuel tank.**

▲ **Properly lift unit and secure in a level position. Use adequate blocks or stands to support unit while draining fuel tank.**

Attach 1/2 ID hose to drain valve. Put metal container under drain, and use screwdriver to open sludge drain valve. Close valve when sludge has drained. Remove hose.

9-7. Overload Protection

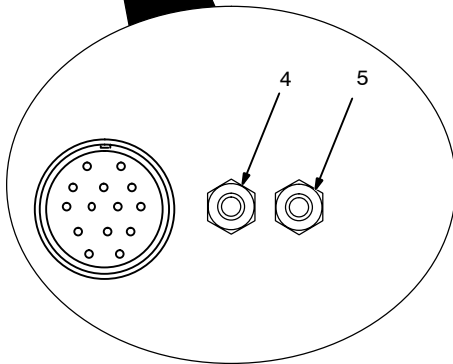
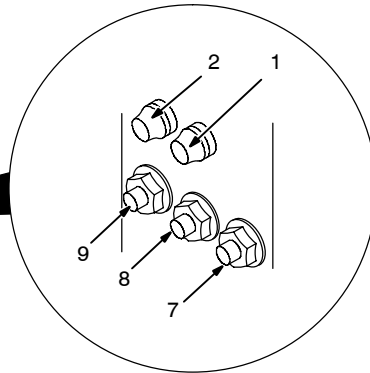
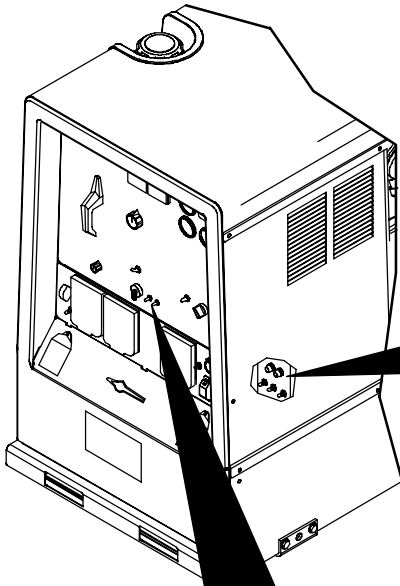
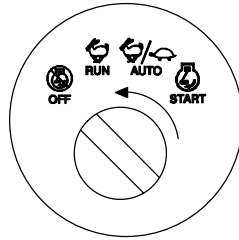

▲ Stop engine.

☞ When a circuit breaker or fuse opens, it usually indicates a more serious problem exists. Contact Factory Authorized Service Agent.

- 1 Fuse F1
- 2 Fuse F2

F1 and F2 protect the stator exciter winding from overload. If F1 opens, weld and generator power is low or stops entirely. If F2 opens, weld output is low or stops entirely. 4 kVA/kW generator power is still available.

- 3 Circuit Breaker CB4 (Not Shown)
- 4 Circuit Breaker CB5 (CC/CV Models Only)
- 5 Circuit Breaker CB6 (CC/CV Models Only)
- 6 Circuit Breaker CB10 (Not Shown)
- 7 Circuit Breaker CB11
- 8 Circuit Breaker CB12
- 9 Circuit Breaker CB13
- 10 Circuit Breaker CB14 (Not Shown)

CB4 protects the welding arc drive (dig) circuit. If CB4 opens, electrode may stick to the workpiece more frequently during low voltage (short arc length) conditions. CB4 automatically resets when the fault is corrected.

CB5 protects the 24 volt ac output to remote receptacle RC14, and 24 volt output to field current regulator board PC1 (CC/CV models only). If CB5 opens, weld output and 24 volt output to RC14 stops. On units with optional three-phase generator, generator power output at receptacle RC5 also stops if CB5 opens.

CB6 protects the 115 volt ac output to remote receptacle RC14 (CC/CV models only). If CB6 opens, 115 volt output to RC14 stops.

CB10 protects the engine battery circuit. If CB10 opens, the engine will not crank. CB10 automatically resets when the fault is corrected.

CB11 protects the engine weld control circuit. On CC models, if CB11 opens the max OCV circuit does not work and open circuit voltage is variable at all times (see max OCV note under Weld Controls in Section 6-2). If CB11 opens on CV models, weld output stops (generator power is still available).

CB12 protects the field flashing circuit. If CB12 opens, the generator may not excite at start-up and weld and generator power output may not be available.

CB13 protects the engine control circuit. If CB13 opens, the engine does not crank.

CB14 protects throttle solenoid TS1 on units with auto idle option. If CB14 opens, the engine does not run at idle speed. CB14 automatically resets when the fault is corrected.

Press button to reset breaker.

9-8. Troubleshooting

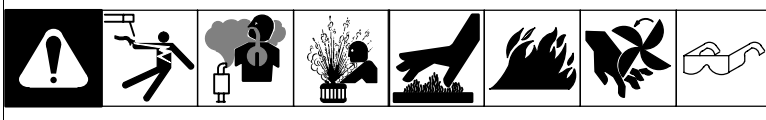

A. Welding – CC Models

Trouble	Remedy
No weld output; generator power output okay at ac receptacles.	Check position of Ampere Range switch.
	Check position of optional Polarity switch.
	Place Amperage Adjust switch in Panel position, or place switch in Remote position and connect remote control to Remote Amperage Adjust receptacle RC13 (see Sections 5-10 and 6-1).
	Check and secure connections to Remote Amperage Adjust receptacle RC13 (see Section 5-10).
	Check fuse F2, and replace if open (see Section 9-7). Have Factory Authorized Service Agent check integrated rectifier SR2 and the rotor.
	Have Factory Authorized Service Agent check brushes and slip rings, and weld excitation circuit.
No weld output or generator power output at ac receptacles.	Disconnect equipment from generator power receptacles during start-up.
	Check fuses F1 and F2, and replace if open (see Section 9-7). Have Factory Authorized Service Agent check integrated rectifier SR1, capacitor C9, integrated rectifier SR2, and the rotor.
	Reset circuit breaker CB12. Have Factory Authorized Service Agent check diode D1 (see Section 9-7).
	Have Factory Authorized Service Agent check brushes and slip rings, and field excitation circuit.
Erratic weld output.	Check and tighten connections inside and outside unit.
	Be sure connection to work piece is clean and tight.
	Use dry, properly stored electrodes.
	Remove excessive coils from weld cables.
	Have Factory Authorized Service Agent check brushes and slip rings.
High weld output.	Check engine speed, and adjust if necessary.
	Have Factory Authorized Service Agent check OCV control circuit.
Low weld output.	Check engine speed, and adjust if necessary.
	Check fuses F1 and F2, and replace if open (see Section 9-7). Have Factory Authorized Service Agent check integrated rectifier SR1, capacitor C9, integrated rectifier SR2, and the rotor.
Electrode sticks to the workpiece more frequently during low voltage (short arc length) conditions.	Circuit breaker CB4 may be open. CB4 automatically resets when the fault is corrected (see Section 9-7). Have Factory Authorized Service Agent check transformer T1 and integrated rectifiers SR4 and SR5.
Low open-circuit voltage.	Check engine speed, and adjust if necessary.
Maximum weld output only in each ampere range (with Stick/TIG Selection switch in Stick position).	Have Factory Authorized Service Agent check control relay CR7.
No remote fine amperage control.	Place Amperage Adjust switch in Remote position.
	Check and secure connections to Remote Amperage Adjust receptacle RC13 (see Section 5-10).
	Reset circuit breaker CB11 (see Section 9-7). Have Factory Authorized Service Agent check control relay CR7.
	Repair or replace remote control device.
	Have Factory Authorized Service Agent check OCV control circuit.

B. Welding – CC/CV Models

Trouble	Remedy
No weld output; generator power output okay at ac receptacles.	Place Process/Contactor switch in a Weld Terminals Always On position, or place switch in a Remote On/Off Switch Required position and connect remote contactor to optional Remote 14 receptacle RC14 (see Sections 5-11 and 7-1).
	Check position of Ampere Range switch.
	Check position of optional Polarity switch or Polarity/AC switch.
	Reset circuit breaker CB11 (see Section 9-7).
	Reset circuit breaker CB5 (see Section 9-7). Check for faulty remote device connected to RC14.
	Check and secure connections to Remote 14 receptacle RC14 (see Section 5-11).
	Have Factory Authorized Service Agent check connector board PC6 and connections.
	Check fuse F2, and replace if open (see Section 9-7). Have Factory Authorized Service Agent check brushes and slip rings, weld excitation circuit, field current regulator board PC1, and the rotor.
No weld output or generator power output at ac receptacles.	Disconnect equipment from generator power receptacles during start-up.
	Check fuses F1 and F2, and replace if open (see Section 9-7). Have Factory Authorized Service Agent check integrated rectifier SR1, capacitor C9, field current regulator board PC1, and the rotor.
	Have Factory Authorized Service Agent check brushes and slip rings, and field excitation circuit.
Erratic weld output.	Check and tighten connections inside and outside unit.
	Be sure connection to work piece is clean and tight.
	Use dry, properly stored electrodes.
	Remove excessive coils from weld cables.
	Have Factory Authorized Service Agent check brushes and slip rings.
High weld output.	Check position of Ampere Range switch and Voltage/Amperage Adjust control.
	Check engine speed, and adjust if necessary.
	Have Factory Authorized Service Agent check field current regulator board PC1, and PC1 voltage feedback circuit.
Voltage/Amperage control does not work when welding in Stick mode.	Place Ampere Range switch in lower range. Voltage/Amperage control does not work with Ampere Range switch in highest range.
Low weld output.	Check position of Ampere Range switch and Voltage/Amperage Adjust control.
	Check engine speed, and adjust if necessary.
	Check fuses F1 and F2, and replace if open (see Section 9-7). Have Factory Authorized Service Agent check integrated rectifier SR1, capacitor C9, field current regulator board PC1, and the rotor.
Electrode sticks to the workpiece more frequently during low voltage (short arc length) conditions.	Circuit breaker CB4 may be open. CB4 automatically resets when the fault is corrected (see Section 9-7). Have Factory Authorized Service Agent check transformer T1 and integrated rectifiers SR4 and SR5.
Low open-circuit voltage.	Check engine speed, and adjust if necessary.
	Check position of Process/Contactor switch.
No remote fine amperage or voltage control.	Place Voltage/Amperage Adjust switch in Remote position.
	Check and secure connections to Remote 14 receptacle RC14 (see Section 5-11).
	Repair or replace remote control device.
	Have Factory Authorized Service Agent check PC1 current sensing leads (36 and 37), and connections.
Constant speed wire feeder does not work.	Reset circuit breaker CB5 or CB6 (see Section 9-7).
	Check and secure connections to Remote 14 receptacle RC14 (see Section 5-11).
	Repair or replace wire feeder.

Trouble	Remedy
Low CV weld output.	Set Ampere Range switch to highest range.
	Increase Voltage/Amperage Adjust Control setting.
Min or max CV weld output only.	Check position of Voltage/Amperage Adjust control and Voltage/Amperage Adjust switch.
	Repair or replace remote control device.
	Have Factory Authorized Service Agent check Amperage/Voltage Adjust Control R1, and field current regulator board PC1.

C. Standard Generator Power

Trouble	Remedy
No generator power output at ac receptacles; weld output okay.	Reset receptacle circuit breakers.
	Reset GFCI receptacle.
No generator power or weld output.	Disconnect equipment from generator power receptacles during start-up.
	Check fuses F1 and F2, and replace if open (see Section 9-7). Have Factory Authorized Service Agent check integrated rectifier SR1, capacitor C9, and the rotor.
	Reset circuit breaker CB12. Have Factory Authorized Service Agent check diode D1 .
	Have Factory Authorized Service Agent check brushes and slip rings, and field excitation circuit.
High output at generator power ac receptacles.	Check engine speed, and adjust if necessary.
	Have Factory Authorized Service Agent adjust generator power field current resistor R3.
Low output at generator power ac receptacles.	Check engine speed, and adjust if necessary.
	Check fuse F1, and replace if open (see Section 9-7). Have Factory Authorized Service Agent check integrated rectifier SR1, resistor R3, and capacitor C9.

D. Optional Three-Phase Generator Power (CC/CV Models Only)

Trouble	Remedy
No or low output at optional three-phase generator/receptacle RC5.	Place Process/Contactor switch in Weld Terminals Always On - Stick position (see Section 7-3).
	Reset circuit breaker CB7(see Section 8-2).
	Reset circuit breaker CB5 (see Section 9-7).
	Check engine weld/power speed, and adjust if necessary (see Section 9-5).
	Have Factory Authorized Service Agent check brushes and slip rings, and field current regulator board PC1.
High output at optional three-phase generator/receptacle RC5.	Check engine weld/power speed, and adjust if necessary (see Section 9-5).
	Have Factory Authorized Service Agent check field current regulator board PC1, and PC1 voltage feedback circuit.
Erratic output at optional three-phase generator/receptacle RC5.	Have Factory Authorized Service Agent check brushes and slip rings, and field current regulator board PC1.

E. Engine

Trouble	Remedy
Engine will not crank.	Check battery, and replace if necessary.
	Check battery connections and tighten if necessary.
	Circuit breaker CB10 may be open. CB10 automatically resets when fault is corrected (see Section 9-7). Have Factory Authorized Service Agent check engine wiring harness and components.
	Check engine wiring harness plug connections.
	Have Factory Authorized Service Agent check control relay CR1 and Engine Control switch S1.
Engine cranks but does not start.	Check fuel level.
	Check battery and replace if necessary. Check engine charging system according to engine manual.
	Have Factory Authorized Service Agent check time delay relay TD1, control relay CR5, fuel pump, and fuel solenoid FS1.
	Air in fuel system. See engine manual.
Engine starts, but stops when Engine Control switch is released.	Check oil level. Automatic shutdown system stops engine if oil pressure is too low or engine temperature is too high (see Section 5-7). Automatic shutdown system is inhibited for 30 seconds after start-up.
	Have Factory Authorized Service Agent check time delay relay TD1, and control relay CR5.
Engine hard to start in cold weather.	Use starting aid switch (see Section 6-1 or 7-1).
	Keep battery in good condition. Store battery in warm area off cold surface.
	Use fuel formulated for cold weather (diesel fuel can gel in cold weather). Contact local fuel supplier for fuel information.
	Use correct grade oil for cold weather (see Section 9-1).
Engine suddenly stops.	Check oil level. Automatic shutdown system stops engine if oil pressure is too low or engine temperature is too high (see Section 5-7). Automatic shutdown system is inhibited for 30 seconds after start-up.
	See engine manual.
Engine slowly stopped and cannot be restarted.	Check fuel level.
	Check engine air and fuel filters (see Sections 9-3 and 9-6).
	See engine manual.
Battery discharges between uses.	Turn Engine Control switch off when unit is not running.
	Clean top of battery with baking soda and water solution; rinse with clear water.
	Recharge or replace battery if necessary.
	Periodically recharge battery (approximately every 3 months).
Engine idles, but does not come up to weld speed (models with idle option only).	Have Factory Authorized Service Agent check idle module PC7 and current transformer CT1.
	Check for obstructed throttle solenoid.
Engine does not run at idle speed (models with idle option only).	CC models: place Stick/TIG Selection switch in Stick position. CC/CV models: place Process/Contactor switch in any position but Remote On/Off Switch Required-TIG.
	Check for obstructed throttle solenoid.
	Have Factory Authorized Service Agent check idle module PC7, and control relays CR3 and CR6.
Engine uses oil during run-in period; wetstacking occurs.	Dry engine according to run-in procedure (see Section 11).

SECTION 10 – ELECTRICAL DIAGRAMS

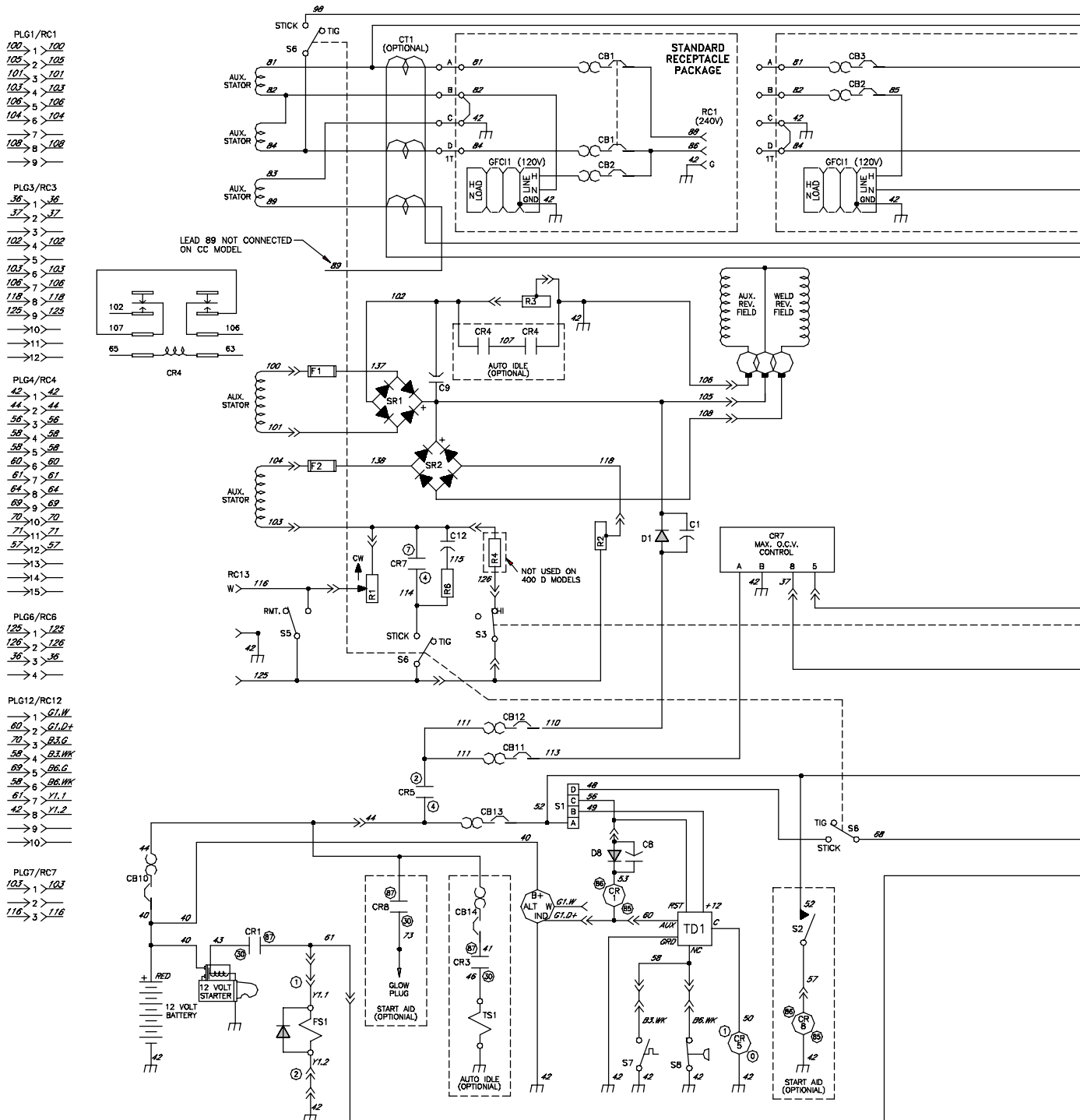

Figure 10-1. Circuit Diagram For CC Welding Generator

⚠ WARNING



ELECTRIC SHOCK HAZARD

- Do not touch live electrical parts.
- Disconnect input power or stop engine before servicing.
- Do not operate with covers removed.
- Have only qualified persons install, use, or service this unit.

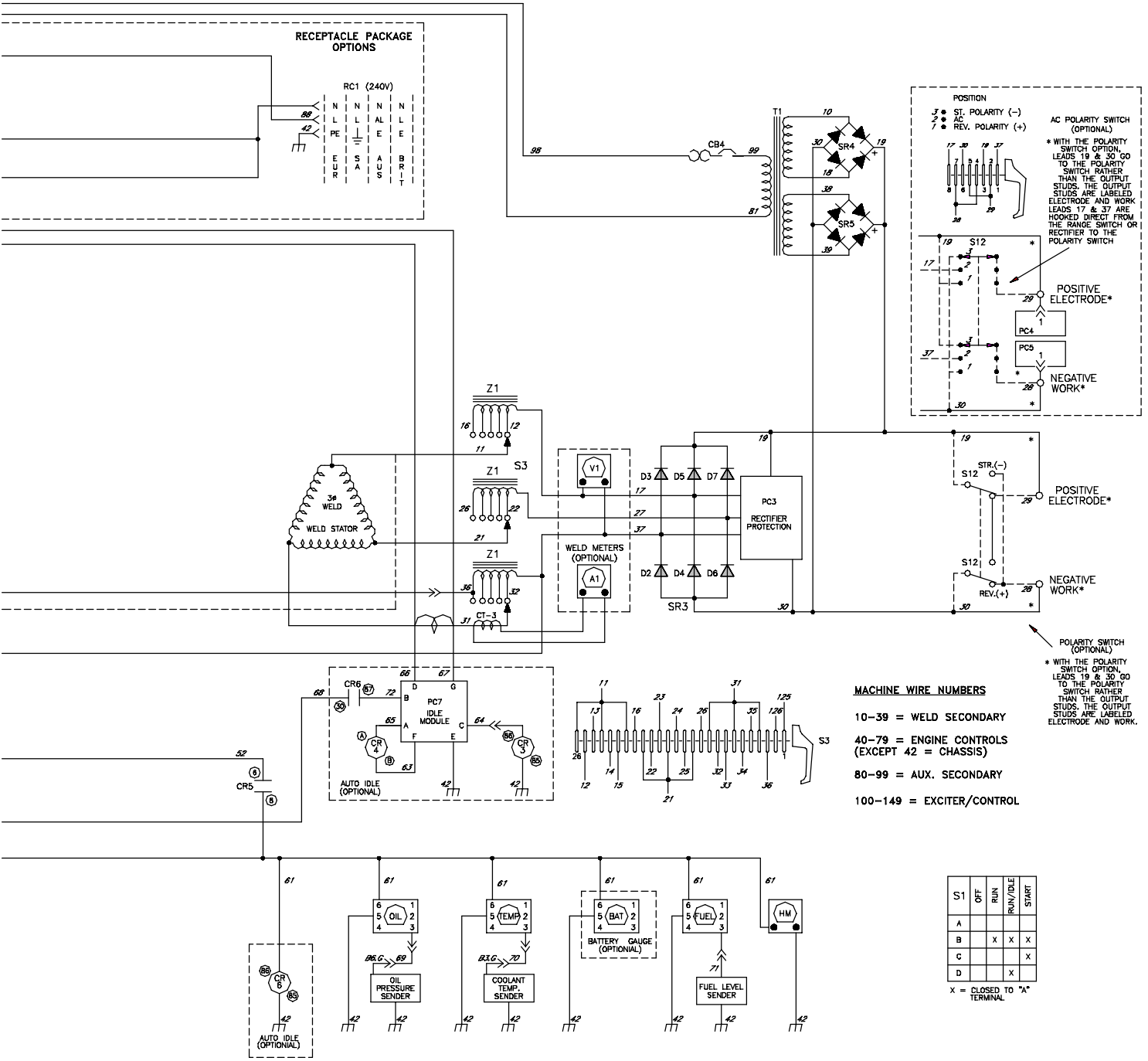

S1	OFF	RUN	RAIN/IDLE	START
A		X	X	X
B	X			
C				X
D			X	

X = CLOSED TO "A" TERMINAL

⚠ WARNING

- Do not touch live electrical parts.
- Disconnect input power or stop engine before servicing.
- Do not operate with covers removed.
- Have only qualified persons install, use, or service this unit.

ELECTRIC SHOCK HAZARD

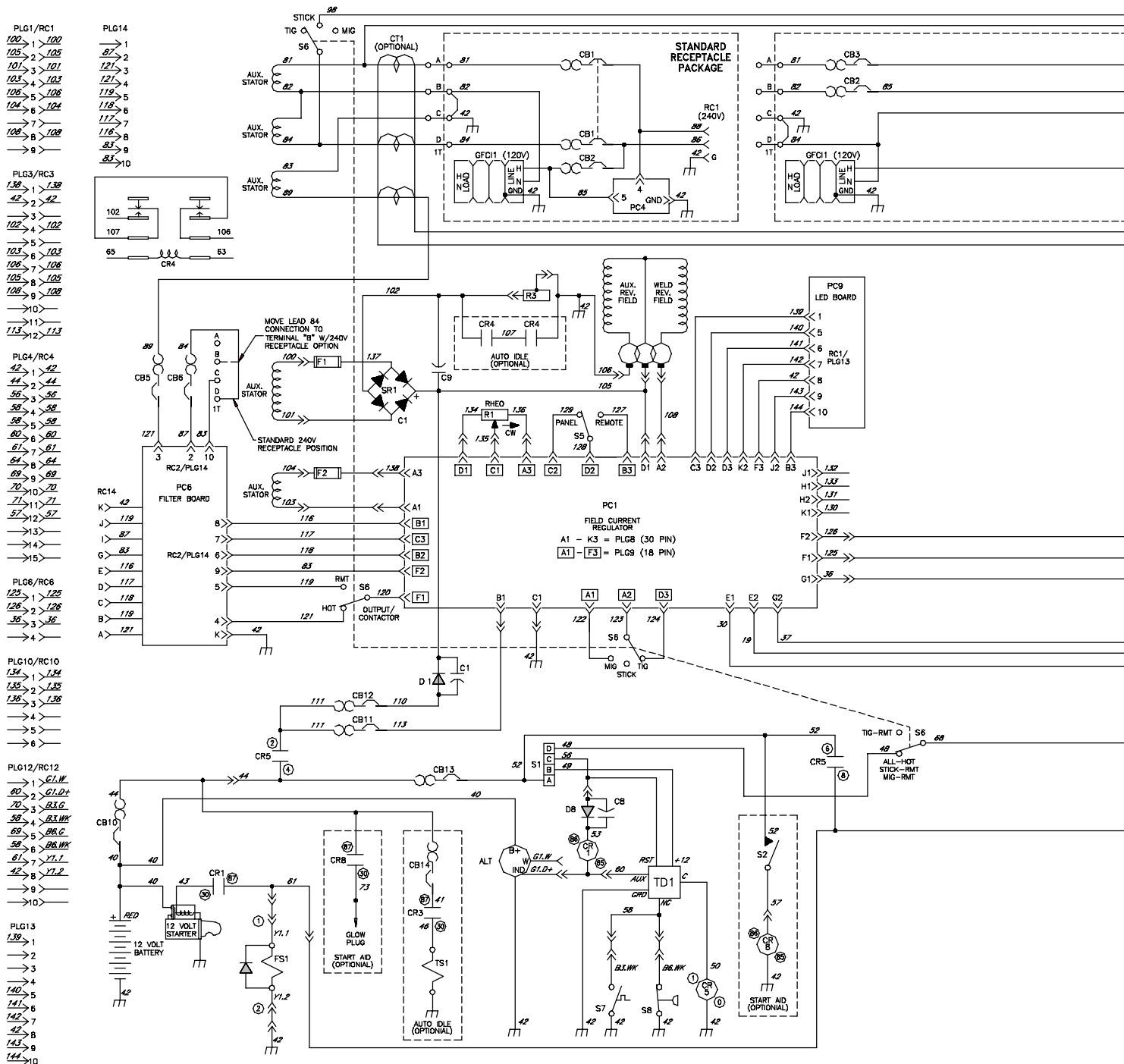
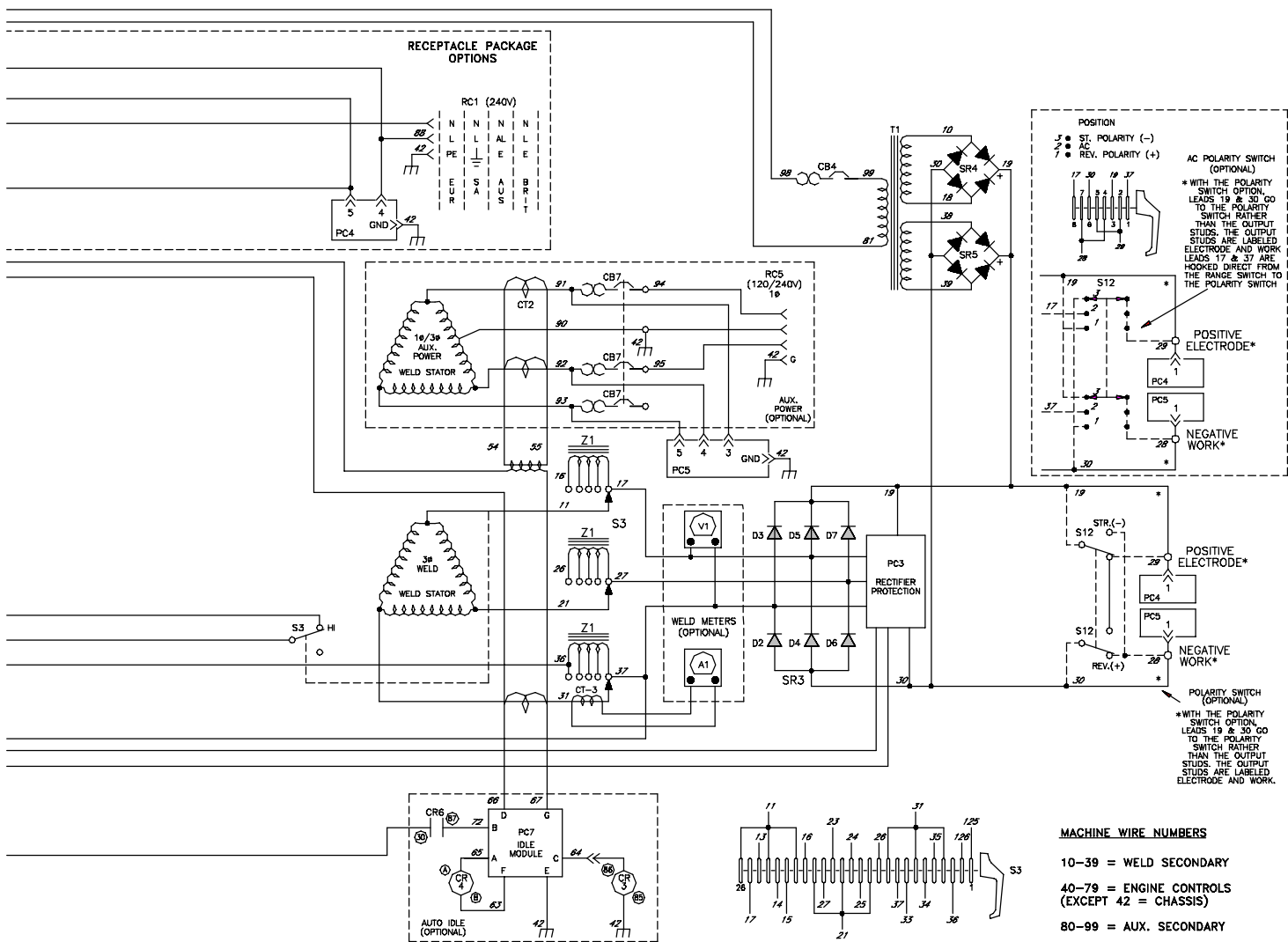

Figure 10-2. Circuit Diagram For CC/CV Welding Generator



MACHINE WIRE NUMBERS

10-39 = WELD SECONDARY

40-79 = ENGINE CONTROLS (EXCEPT 42 = CHASSIS)

80-99 = AUX. SECONDARY

100-149 = EXCITER/CONTROL

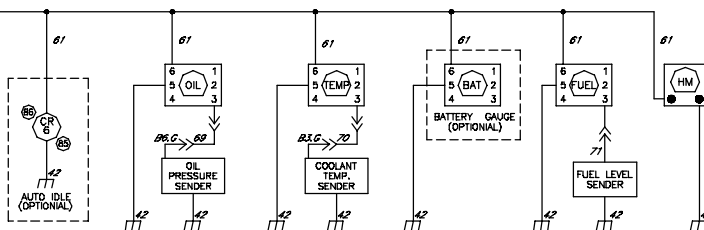
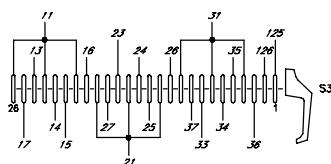

SWITCH NUMBERS	LEAD NUMBERS	REMOTE			ELECTRODE HOT	
		TIC	STICK	MIG	STICK	MIG
1-2	119-120	X	X	X		
2-3	120-121			X	X	X
5-6	122-123			X	X	
8-7	123-124	X				X
9-10	48-68	X	X	X	X	X
11-12	84-98				X	

X = CONTACT CLOSED

S1	OFF	RUN	REAN/IDLE	START
A				
B	X	X	X	X
C				X
D			X	

X = CLOSED TO "A" TERMINAL

SECTION 11 – RUN-IN PROCEDURE

run_in1 8/01

11-1. Wetstacking

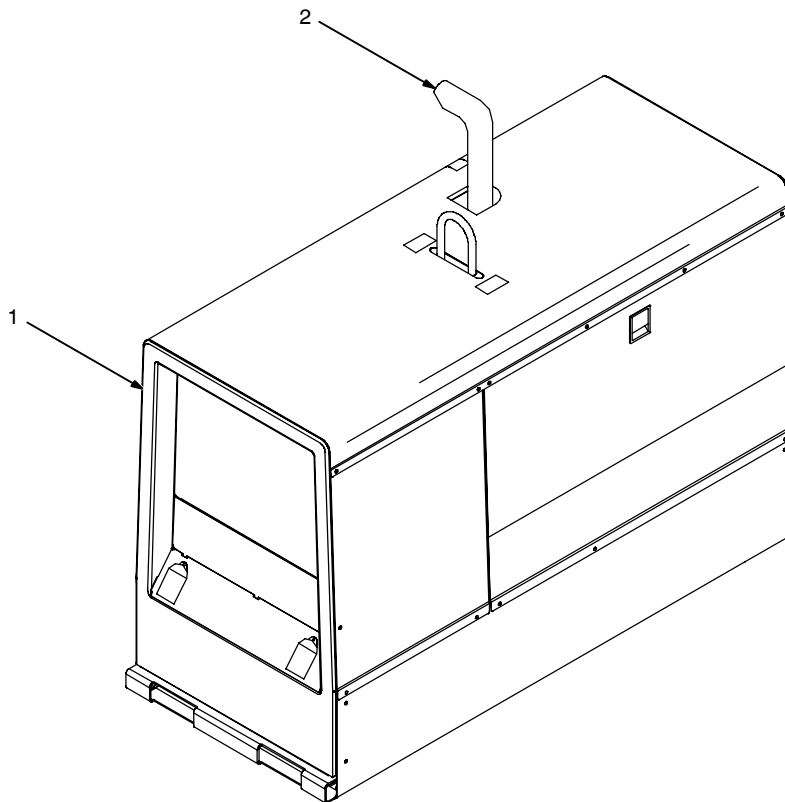

▲ **Do not perform run-in procedure at less than 20 volts weld output and do not exceed duty cycle or equipment damage may occur.**

1 Welding Generator

Run diesel engines near rated voltage and current during run-in period to properly seat piston rings and prevent wetstacking. See nameplate, rating label, or specifications section in this manual to find rated voltage and current.

☞ *Do not idle engine longer than necessary. Piston rings seat faster if engine runs at weld/power rpm, and the welding generator is kept loaded during run-in.*

2 Engine Exhaust Pipe

Wetstacking is unburned fuel and oil in the exhaust pipe and occurs during run-in if the engine is run too long at light load or idle rpm.

If exhaust pipe is coated with a wet, black, tar-like substance, dry the engine using one of the following run-in procedures.

See the engine manual for additional engine run-in information.

11-2. Run-In Procedure Using Load Bank

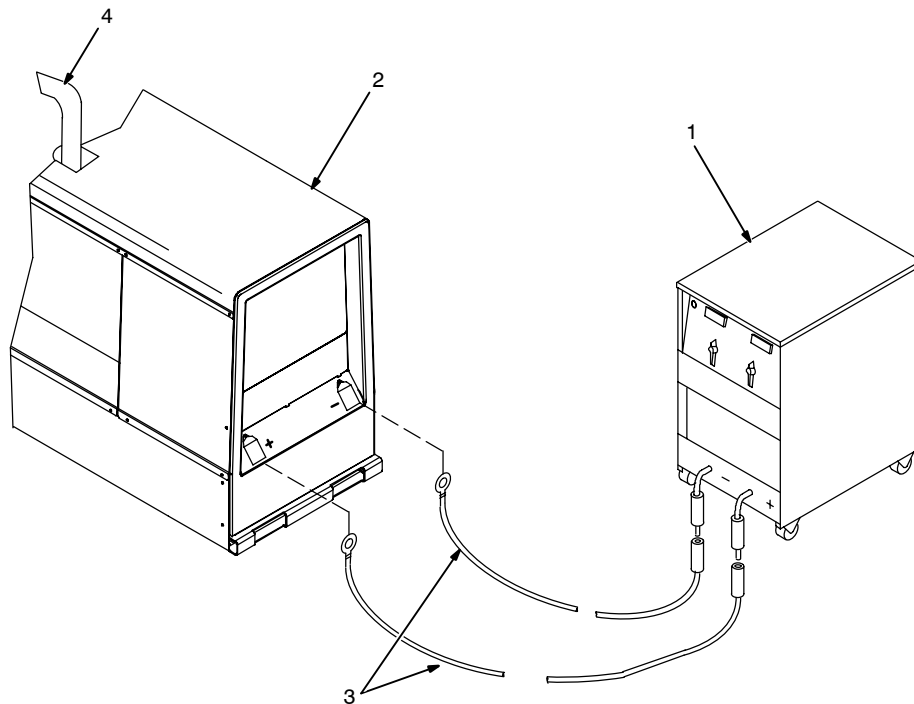

- ▲ **Stop engine.**
- ▲ **Do not touch hot exhaust pipe, engine parts, or load bank/grid.**
- ▲ **Keep exhaust and pipe away from flammables.**
- ▲ **Do not perform run-in procedure at less than 20 volts weld output and do not exceed duty cycle or equipment damage may occur.**

1 Load Bank

Turn all load bank switches Off. If needed, connect load bank to 115 volts ac wall receptacle or generator auxiliary power receptacle.

2 Welding Generator

Place A/V range switch in maximum position, A/V control in minimum position, and Output Selector switch (if present) in either DC position.

3 Weld Cables

Connect load bank to generator weld output terminals using proper size weld cables with correct connectors. Observe correct polarity.

Start engine and run for several minutes.

Set load bank switches and then adjust generator A/V control so load equals rated voltage and current of generator (see nameplate, rating label, or the specifications section in this manual).

Check generator and load bank meters after first five minutes then every fifteen minutes to be sure generator is loaded properly.

 *Check oil level frequently during run-in; add oil if needed.*

After one hour (minimum) place A/V control in minimum position, then turn off load bank to remove load. Run engine several minutes at no load.

- ▲ **Stop engine and let cool.**

4 Engine Exhaust Pipe

Repeat procedure if wetstacking is present.

11-3. Run-In Procedure Using Resistance Grid

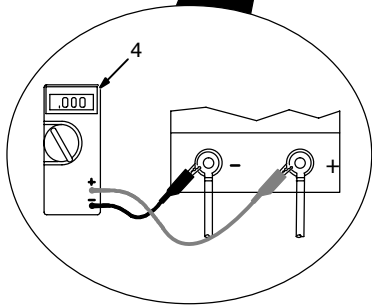
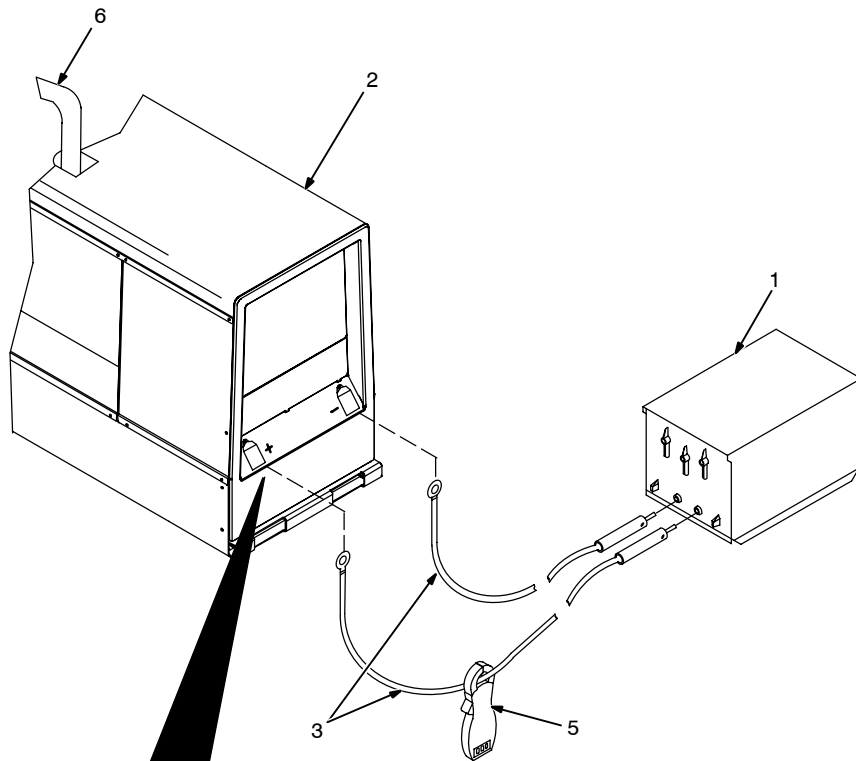

- ▲ **Stop engine.**
- ▲ **Do not touch hot exhaust pipe, engine parts, or load bank/grid.**
- ▲ **Keep exhaust and pipe away from flammables.**
- ▲ **Do not perform run-in procedure at less than 20 volts weld output and do not exceed duty cycle or equipment damage may occur.**

1 Resistance Grid

Use grid sized for generator rated output.

Turn Off grid.

2 Welding Generator

Place A/V range switch in maximum position, A/V control in minimum position, and Output Selector switch (if present) in either DC position.

3 Weld Cables

Connect grid to generator weld output terminals using proper size weld cables with correct connectors (polarity is not important).

4 Voltmeter

5 Clamp-On Ammeter

Connect voltmeter and ammeter as shown, if not provided on generator.

Start engine and run for several minutes.

Set grid switches and then adjust generator A/V control so load equals rated voltage and current of the generator (see nameplate, rating label, or the specifications section in this manual).

Check generator and meters after first five minutes then every fifteen minutes to be sure generator is loaded properly.

☞ *Check oil level frequently during run-in; add oil if needed.*

After one hour (minimum), place A/V control in minimum position, then shut down grid to remove load. Run engine several minutes at no load.

▲ **Stop engine and let cool.**

6 Engine Exhaust Pipe



Repeat procedure if wetstacking is present.

SECTION 12 – GENERATOR POWER GUIDELINES

NOTE

The views in this section are intended to be representative of all engine-driven welding generators. Your unit may differ from those shown.

12-1. Selecting Equipment



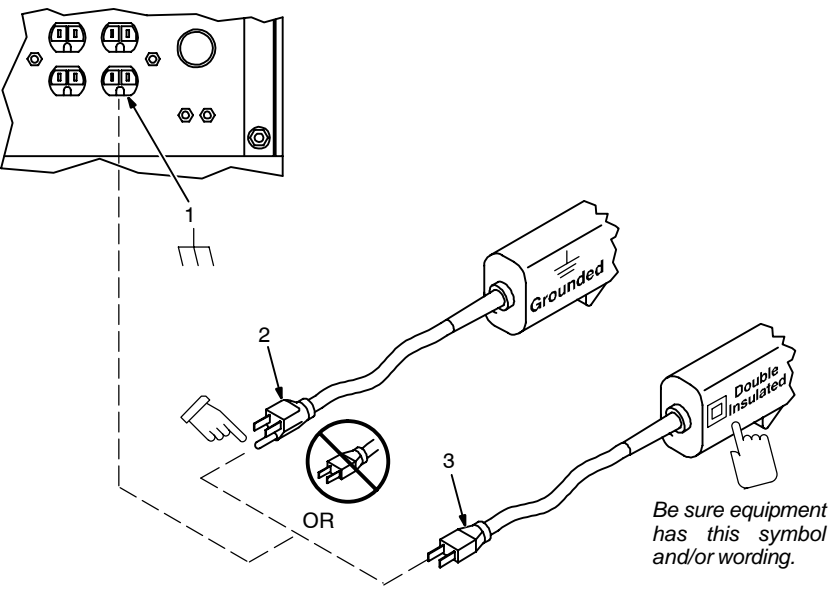

- 1 Generator Power Receptacles – Neutral Bonded To Frame
- 2 3-Prong Plug From Case Grounded Equipment
- 3 2-Prong Plug From Double Insulated Equipment

▲ **Do not use 2-prong plug unless equipment is double insulated.**

gen_pwr 11/02 – Ref. ST-159 730 / ST-800 577

12-2. Grounding Generator To Truck Or Trailer Frame

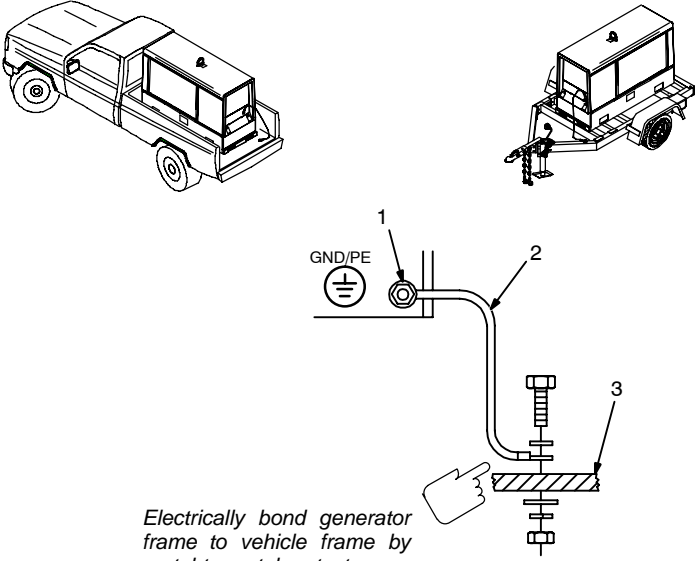

Electrically bond generator frame to vehicle frame by metal-to-metal contact.

▲ **Always ground generator frame to vehicle frame to prevent electric shock and static electricity hazards.**

- 1 Equipment Grounding Terminal (On Front Panel)
- 2 Grounding Cable (Not Supplied)
- 3 Metal Vehicle Frame

Connect cable from equipment ground terminal to metal vehicle frame. Use #10 AWG or larger insulated copper wire.

▲ **If unit does not have GFCI receptacles, use GFCI-protected extension cord.**

▲ **Bed liners, shipping skids, and some running gear insulate the welding generator from the vehicle frame. Always connect a ground wire from the generator equipment grounding terminal to bare metal on the vehicle frame as shown.**

S-0854

12-3. Grounding When Supplying Building Systems

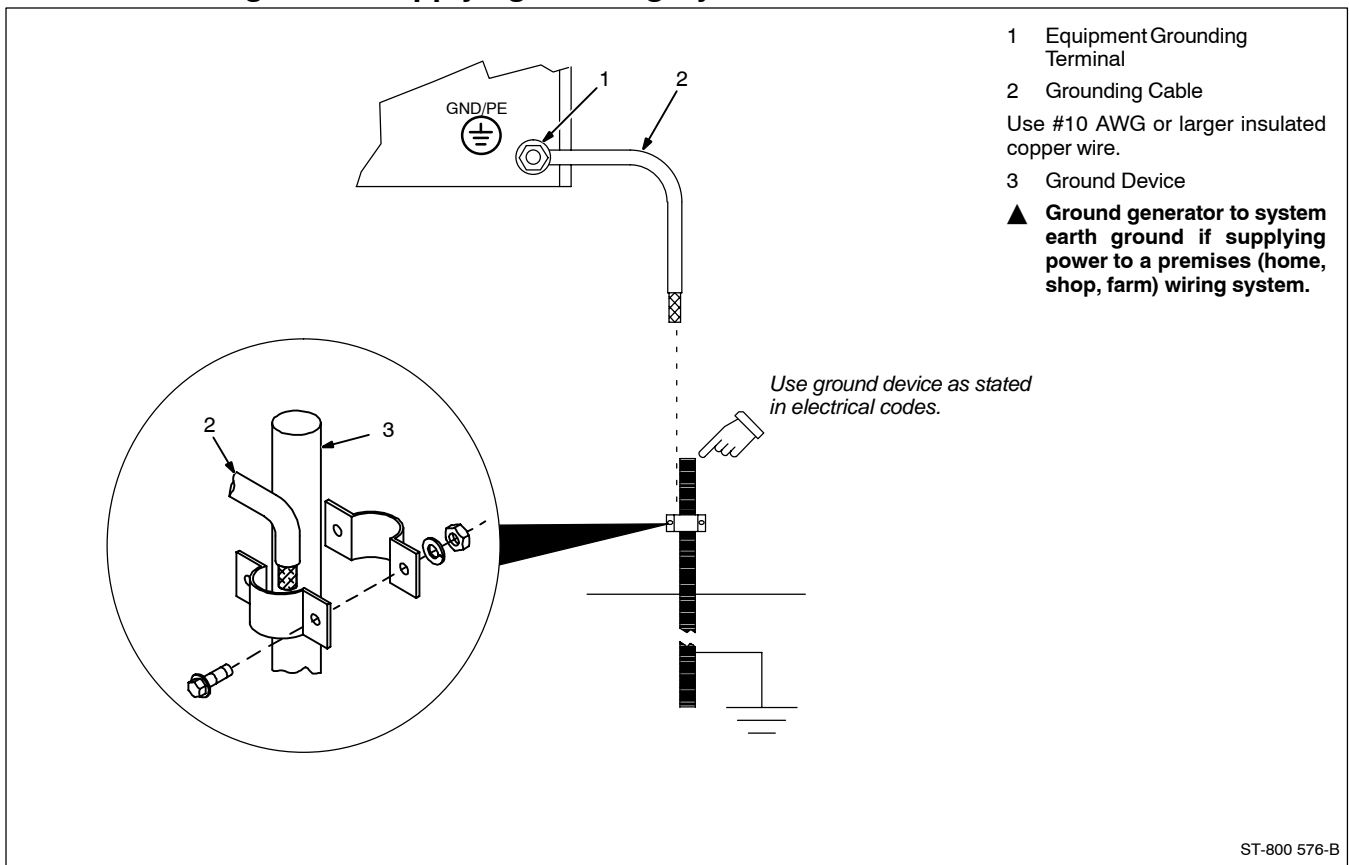

12-4. How Much Power Does Equipment Require?

VOLTS	115
AMPS	4.5
Hz	60

1 Resistive Load
 A light bulb is a resistive load and requires a constant amount of power.

2 Non-Resistive Load
 Equipment with a motor is a non-resistive load and requires approximately six times more power while starting the motor than when running (see Section 12-8).

3 Rating Data
 Rating shows volts and amperes, or watts required to run equipment.

AMPERES x VOLTS = WATTS

EXAMPLE 1: If a drill uses 4.5 amperes at 115 volts, calculate its running power requirement in watts.

$$4.5 \text{ A} \times 115 \text{ V} = 520 \text{ W}$$

The load applied by the drill is 520 watts.

EXAMPLE 2: If three 200 watt flood lamps are used with the drill from Example 1, add the individual loads to calculate total load.

$$(200 \text{ W} + 200 \text{ W} + 200 \text{ W}) + 520 \text{ W} = 1120 \text{ W}$$

The total load applied by the three flood lamps and drill is 1120 watts.

S-0623

12-5. Approximate Power Requirements For Industrial Motors

Industrial Motors	Rating	Starting Watts	Running Watts
Split Phase	1/8 HP	800	300
	1/6 HP	1225	500
	1/4 HP	1600	600
	1/3 HP	2100	700
	1/2 HP	3175	875
Capacitor Start-Induction Run	1/3 HP	2020	720
	1/2 HP	3075	975
	3/4 HP	4500	1400
	1 HP	6100	1600
	1-1/2 HP	8200	2200
	2 HP	10550	2850
	3 HP	15900	3900
Capacitor Start-Capacitor Run	5 HP	23300	6800
	1-1/2 HP	8100	2000
	5 HP	23300	6000
	7-1/2 HP	35000	8000
	10 HP	46700	10700
Fan Duty	1/8 HP	1000	400
	1/6 HP	1400	550
	1/4 HP	1850	650
	1/3 HP	2400	800
	1/2 HP	3500	1100

12-6. Approximate Power Requirements For Farm/Home Equipment

Farm/Home Equipment	Rating	Starting Watts	Running Watts
Stock Tank De-Icer		1000	1000
Grain Cleaner	1/4 HP	1650	650
Portable Conveyor	1/2 HP	3400	1000
Grain Elevator	3/4 HP	4400	1400
Milk Cooler		2900	1100
Milker (Vacuum Pump)	2 HP	10500	2800
FARM DUTY MOTORS	1/3 HP	1720	720
Std. (e.g. Conveyors,	1/2 HP	2575	975
Feed Augers, Air	3/4 HP	4500	1400
Compressors)	1 HP	6100	1600
	1-1/2 HP	8200	2200
	2 HP	10550	2850
	3 HP	15900	3900
	5 HP	23300	6800
High Torque (e.g. Barn	1-1/2 HP	8100	2000
Cleaners, Silo Unloaders,	5 HP	23300	6000
Silo Hoists, Bunk Feeders)	7-1/2 HP	35000	8000
	10 HP	46700	10700
3-1/2 cu. ft. Mixer	1/2 HP	3300	1000
High Pressure 1.8 Gal/Min	500 PSI	3150	950
Washer 2 gal/min	550 PSI	4500	1400
2 gal/min	700 PSI	6100	1600
Refrigerator or Freezer		3100	800
Shallow Well Pump	1/3 HP	2150	750
	1/2 HP	3100	1000
Sump Pump	1/3 HP	2100	800
	1/2 HP	3200	1050

12-7. Approximate Power Requirements For Contractor Equipment

Contractor	Rating	Starting Watts	Running Watts
Hand Drill	1/4 in	350	350
	3/8 in	400	400
	1/2 in	600	600
Circular Saw	6-1/2 in	500	500
	7-1/4 in	900	900
	8-1/4 in	1400	1400
Table Saw	9 in	4500	1500
	10 in	6300	1800
Band Saw	14 in	2500	1100
Bench Grinder	6 in	1720	720
	8 in	3900	1400
	10 in	5200	1600
Air Compressor	1/2 HP	3000	1000
	1 HP	6000	1500
	1-1/2 HP	8200	2200
	2 HP	10500	2800
Electric Chain Saw	1-1/2 HP, 12 in	1100	1100
	2 HP, 14 in	1100	1100
Electric Trimmer	Standard 9 in	350	350
	Heavy Duty 12 in	500	500
Electric Cultivator	1/3 HP	2100	700
Elec. Hedge Trimmer	18 in	400	400
Flood Lights	HID	125	100
	Metal Halide	313	250
	Mercury	1000	
	Sodium	1400	
Submersible Pump	Vapor	1250	1000
	400 gph	600	200
Centrifugal Pump	900 gph	900	500
Floor Polisher	3/4 HP, 16 in	4500	1400
	1 HP, 20 in	6100	1600
High Pressure Washer	1/2 HP	3150	950
	3/4 HP	4500	1400
	1 HP	6100	1600
55 gal Drum Mixer	1/4 HP	1900	700
Wet & Dry Vac	1.7 HP	900	900
	2-1/2 HP	1300	1300

12-8. Power Required To Start Motor

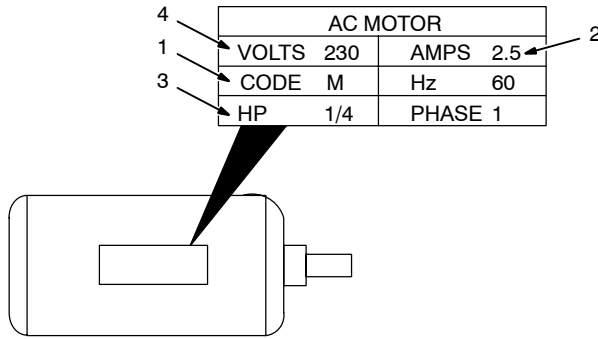

- 1 Motor Start Code
- 2 Running Amperage
- 3 Motor HP
- 4 Motor Voltage

To find starting amperage:

Step 1: Find code and use table to find kVA/HP. If code is not listed, multiply running amperage by six to find starting amperage.

Step 2: Find Motor HP and Volts.

Step 3: Determine starting amperage (see example).

Welding generator amperage output must be at least twice the motor's running amperage.

Single-Phase Induction Motor Starting Requirements

Motor Start Code	G	H	J	K	L	M	N	P
KVA/HP	6.3	7.1	8.0	9.0	10.0	11.2	12.5	14.0

$$\frac{\text{kVA/HP} \times \text{HP} \times 1000}{\text{VOLTS}} = \text{STARTING AMPERAGE}$$

EXAMPLE: Calculate the starting amperage required for a 230 V, 1/4 HP motor with a motor start code of M.

Volts = 230 HP = 1/4 Using Table, Code M results in kVA/HP = 11.2

$$\frac{11.2 \times 1/4 \times 1000}{230} = 12.2 \text{ A} \quad \text{Starting the motor requires 12.2 amperes.}$$

S-0624

12-9. How Much Power Can Generator Supply?

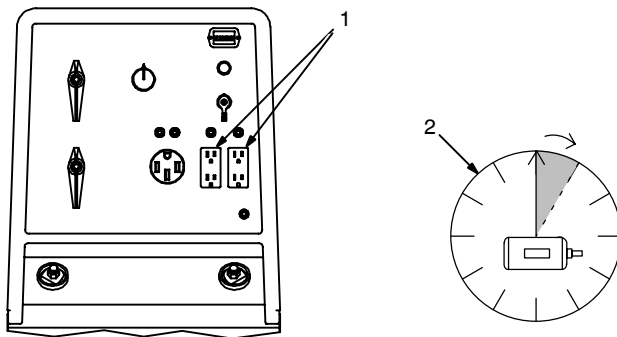

- 1 Limit Load To 90% Of Generator Output

Always start non-resistive (motor) loads in order from largest to smallest, and add resistive loads last.

- 2 5 Second Rule

If motor does not start within 5 seconds, turn off power to prevent motor damage. Motor requires more power than generator can supply.

Ref. ST-800 396-A / S-0625

12-11. Selecting Extension Cord (Use Shortest Cord Possible)



Cord Lengths for 120 Volt Loads

▲ If unit does not have GFCI receptacles, use GFCI-protected extension cord.

Current (Amperes)	Load (Watts)	Maximum Allowable Cord Length in ft (m) for Conductor Size (AWG)*					
		4	6	8	10	12	14
5	600			350 (106)	225 (68)	137 (42)	100 (30)
7	840		400 (122)	250 (76)	150 (46)	100 (30)	62 (19)
10	1200	400 (122)	275 (84)	175 (53)	112 (34)	62 (19)	50 (15)
15	1800	300 (91)	175 (53)	112 (34)	75 (23)	37 (11)	30 (9)
20	2400	225 (68)	137 (42)	87 (26)	50 (15)	30 (9)	
25	3000	175 (53)	112 (34)	62 (19)	37 (11)		
30	3600	150 (46)	87 (26)	50 (15)	37 (11)		
35	4200	125 (38)	75 (23)	50 (15)			
40	4800	112 (34)	62 (19)	37 (11)			
45	5400	100 (30)	62 (19)				
50	6000	87 (26)	50 (15)				

*Conductor size is based on maximum 2% voltage drop

Cord Lengths for 240 Volt Loads

▲ If unit does not have GFCI receptacles, use GFCI-protected extension cord.

Current (Amperes)	Load (Watts)	Maximum Allowable Cord Length in ft (m) for Conductor Size (AWG)*					
		4	6	8	10	12	14
5	1200			700 (213)	450 (137)	225 (68)	200 (61)
7	1680		800 (244)	500 (152)	300 (91)	200 (61)	125 (38)
10	2400	800 (244)	550 (168)	350 (107)	225 (69)	125 (38)	100 (31)
15	3600	600 (183)	350 (107)	225 (69)	150 (46)	75 (23)	60 (18)
20	4800	450 (137)	275 (84)	175 (53)	100 (31)	60 (18)	
25	6000	350 (107)	225 (69)	125 (38)	75 (23)		
30	7000	300 (91)	175 (53)	100 (31)	75 (23)		
35	8400	250 (76)	150 (46)	100 (31)			
40	9600	225 (69)	125 (38)	75 (23)			
45	10,800	200 (61)	125 (38)				
50	12,000	175 (53)	100 (31)				

*Conductor size is based on maximum 2% voltage drop

SECTION 13 – PARTS LIST

 Hardware is common and not available unless listed.

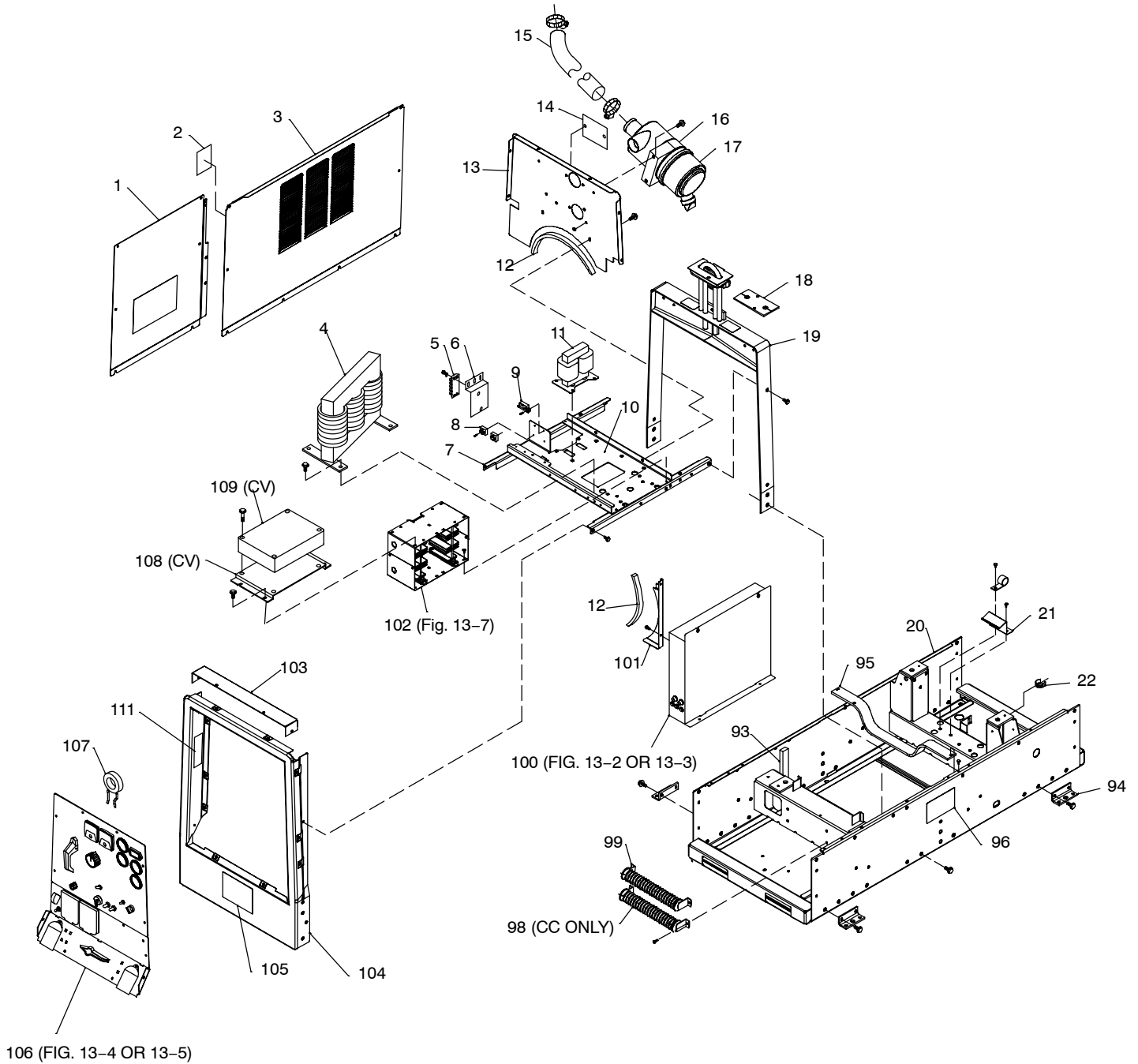

CC CC Models Only
CV CC/CV Models Only

Figure 13-1. Main Assembly

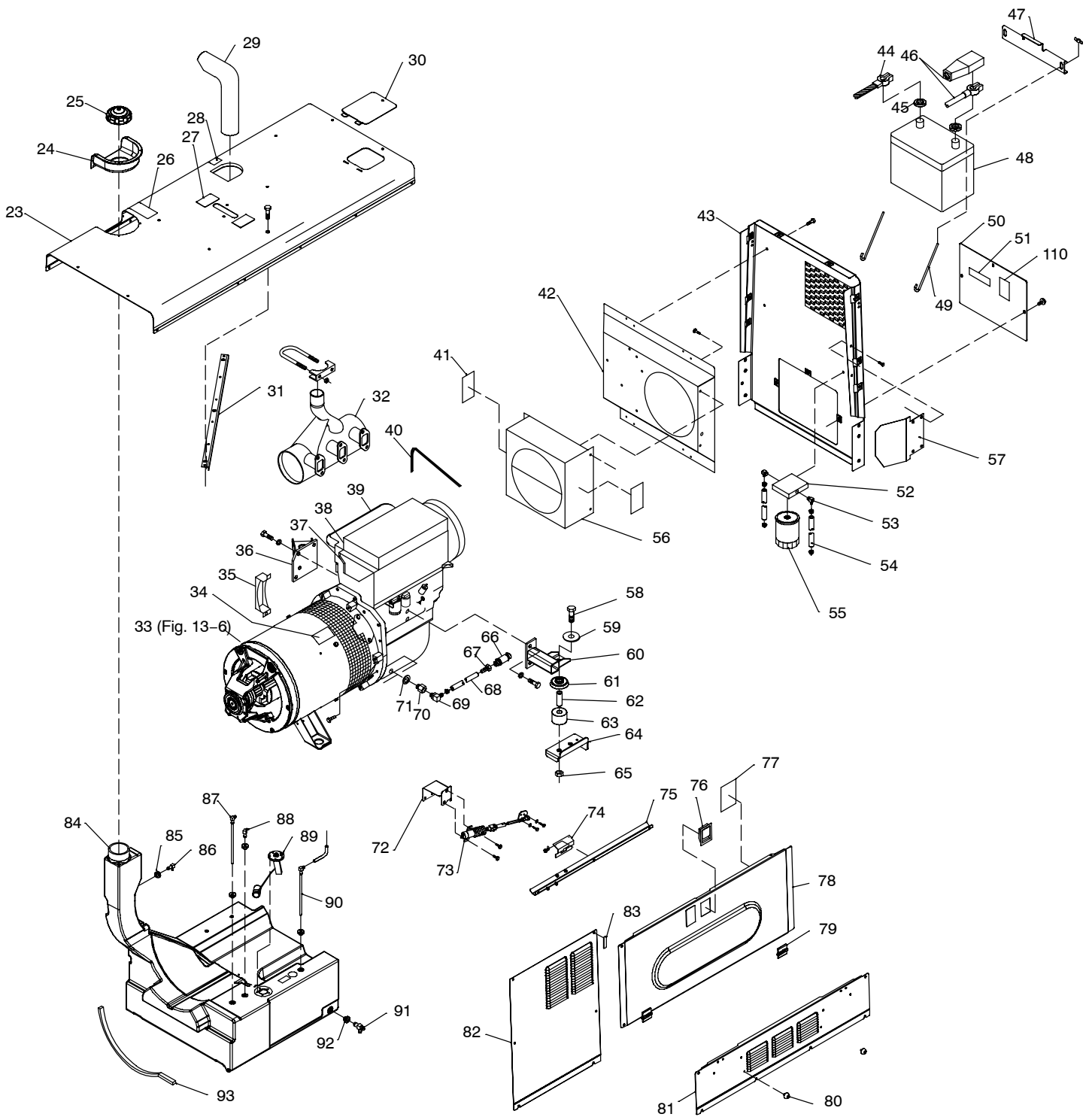

Item No.	Dia. Mkgs.	Part No.	Description	Quantity
Figure 13-1. Main Assembly				
...	1	189 824	PANEL, gen LH	1
...	1	◆199 294	PANEL, gen LH ss	1
...	2	191 623	LABEL, warning all panels must be in place while running	2
...	3	+189 828	PANEL, engine side	1
...	3	◆+199 301	PANEL, engine side ss	1
...	4	Z1 c _c 214 972	REACTOR, ac	1
...	4	Z1 c _v 214 964	REACTOR, ac	1
...	5	1T 038 621	BLOCK, term 30A 4 pole frict term str	1
.....		038 620	LINK, jumper term blk 30A	2
...	6	081 499	BRACKET, mtg strip terminal	1
...	7	206 352	BRACE, front to center upright	2
...	8	SR4, SR5 215 909	RECTIFIER	2
...	9	CB4 045 061	CIRCUIT BREAKER, auto reset 24vdc 7 amp	1
...	10	201 697	PAN, reactor and rectifier	1
...	11	T1 201 613	TRANSFORMER w/bracket	1
...	11	◆T1 205 636	TRANSFORMER w/bracket (environmental coating)	1
...	12	173 352	EXTRUSION, rubber clamp/bulb (order by ft)	3ft
...	13	189 708	FIREWALL, top	1
...	14	191 307	COVER, plate	1
...	15	191 829	HOSE, air cleaner	1
...	16	189 763	BRACKET, mtg air cleaner	1
...	17	189 764	AIR CLEANER, intake	1
.....		*192 938	FILTER, air element primary	1
.....		*◆192 939	FILTER, air element safety	1
...	18	189 464	SEAL, weather lift eye	1
.....		173 909	HOSE, sae .312 id x .560 od x 24.000 (order by ft)	2
...	19	201 658	UPRIGHT, center assembly	1
...	20	+200 999	BASE	1
...	20	◆+203 382	BASE e-coat	1
...	21	196 220	BRACKET, hold down fuel tank rear	1
...	22	192 362	BRACKET, mtg nyl 1/2 conduit	1
...	23	+201 934	COVER, top	1
...	23	◆+202 640	COVER, top ss	1
...	24	189 052	GROMMET, plastic neck filler fuel	1
...	25	190 198	CAP, tank screw-on 3.500 in w/vent	1
...	26	192 041	LABEL, use diesel fuel only	1
...	26	176 103	LABEL, use diesel fuel only (Wordless Label)	1
...	27	108 487	LABEL, warning falling equipment	2
...	27	176 104	LABEL, warning falling equipment (Wordless Label)	2
...	28	176 230	LABEL, warning hot exhaust	1
...	29	105 734	PIPE, muffler extension elbow 1.875 OD	1
...	29	201 592	PIPE, exhaust (export models)	1
...	30	201 851	COVER, radiator access	1
...	31	191 354	SUPPORT, cover	1
...	31	202 633	SUPPORT, cover e-coat	1
...	32	200 731	MANIFOLD, exhaust muffler (Included w/Engine – export models)	1
.....		010 875	CLAMP, muffler 2.000 dia u pld	1
...	33	Figure 13-6	GENERATOR	1
...	34	013 367	LABEL, warning moving parts	2
...	34	176 106	LABEL, warning moving parts (Wordless Label)	2
...	35	191 577	GUARD, starter	1
...	36	197 370	BRACKET, mtg engine LH	1
...	37	190 951	EDGE TRIM, styel tl750-b2 x 1/16 black w/clips 1.625	1
...	38	197 639	BAFFLE, air	1

Item No.	Dia. Mkgs.	Part No.	Description	Quantity
Figure 13-1. Main Assembly (Continued)				
39		213 878	ENGINE, Deutz dsl elec F3L2011 (includes manifold/muffler)	1
		*067 265	FILTER, oil (engine)	1
		*192 744	FILTER, fuel spin-on	1
		*066 217	FILTER, fuel secondary	1
		*195 745	SWITCH, oil pressure	1
		*195 746	SENDER, coolant	1
		179 561	EXTRUSION, rubber clamp/bulb 2.250lg (order by ft)	1
		179 562	EXTRUSION, rubber clamp/bulb 3.000lg (order by ft)	1
40		*216 959	BELT, blower	1
41		147 923	LABEL, warning moving parts	2
42		201 714	BOX, air intake	1
43		201 748	UPRIGHT, rear	1
43		◆202 638	UPRIGHT, rear ss	1
44		190 206	CABLE, bat neg 42 in lg No. 2 awg w/clamp and .375rng	1
45		108 081	TERMINAL PROTECTOR, battery post mtg	2
46		190 207	CABLE, bat pos 45 in lg No. 1 awg w/clamp and .406rng	1
47		203 430	BRACKET, battery holddown	1
48		190 897	BATTERY, stor 12V 650crk 110rsv gp 24	1
49		201 006	BOLT, j stl .312-18 x 8.500 pld	2
50		+201 183	COVER, battery access	1
50		202 639	COVER, battery access ss	1
51		168 385	LABEL, warning battery explosion can blind	1
51		176 108	LABEL, warning battery explosion can blind (Wordless Label)	1
52		206 297	BASE, fuel filter w/fittings	1
53		145 282	FITTING, hose brs barbed elbow M 5/16tbg x 1/4NPT	2
54		196 465	HOSE, SAE .312 ID X .560 OD X 23.000	1
		200 032	HOSE, SAE .312 ID X .560 OD X 38.000	1
55		*192 744	FILTER, fuel spin-on	1
56		+201 715	BOX, air intake	1
57		+215 252	GUARD, belt	1
58		199 849	SCREW, 625-11 x 4.00hexhd pln gr 5 pld	4
59		071 731	WASHER, flat .656 ID x 2.250 OD x .187T stl pld	4
60		197 366	BRACKET, mtg engine RH	1
61		071 890	RETAINER, mount eng/gen	4
62		071 730	TUBING, stl .875 OD x 12ga wall x 2.500	4
63		083 476	MOUNT, eng/gen nprn .875 ID x 2.500 OD x 2.000	4
64		197 373	BRACKET, support base RH	1
65		135 205	NUT, 625-11 .94hex .76H stl pld elastic stop nut	4
		199 507	HOSE, oil drain assy 20 in (consisting of)	1
66		165 271	VALVE, oil drain 3/8-18NPTF	1
67		176 529	FITTING, hose brs barbed fem 1/2tbg x 3/8NPT	1
68		113 854	HOSE, SAE .500 ID x .780 OD xc oil (order by ft)	2ft
69		176 528	FITTING, hose brs barbed elbow fem 1/2 tbg x 1/2 NPT	1
70		173 336	FITTING, adapter oil drain	1
71			WASHER, oil drain (available through engine manufacturer)	1
72		219 229	BRACKET, mtg solenoid	1
73	TS1	◆174 064	IDLE SOLENOID ASSEMBLY	1
74		190 992	KEEPER, latch engine access door	1
75		190 076	CHANNEL, stiffener engine access	1
75		◆202 635	CHANNEL, stiffener engine access e-coat	1
76		199 592	LATCH, paddle series 20 (black)	1
77		215 233	LABEL, diesel engine maintenance Deutz (Wordless Label)	1
78		+200 989	DOOR, engine access	1
78		+210 736	DOOR, engine access ss	1
79		189 975	HINGE, door access 180deg	2

Item No.	Dia. Mkgs.	Part No.	Description	Quantity
Figure 13-1. Main Assembly (Continued)				
80		208 141	STOP, door	2
81		189 826	PANEL, rocker	1
81		199 298	PANEL, rocker ss	1
82		189 827	PANEL, gen RH	1
82		199 300	PANEL, gen RH ss	1
83		191 626	BUMPER, door engine access	2
84		218 087	TANK, fuel (consisting of)	1
85		124 253	BUSHING, tank fuel	4
		084 173	CLAMP, hose .460 – .545clp dia slftng	2
86		189 912	FITTING, stl barbed elbow w/.047 in orf zinc pld	1
87		189 909	FITTING, stand pipe hose .250 x 9.260 lg 90deg zinc	1
88		189 913	FITTING, stl barbed elbow zinc pld	1
89		190 142	SENDER, fuel gauge 9.7500 deep tank	1
90		189 910	FITTING, stand pipe hose .3125 x 9.260 lg 90deg zinc	1
91		189 908	VALVE, drain fuel 180deg	1
92		181 572	BUSHING, tank fuel	1
93		191 446	EXTRUSION, rubber w/adhesive 1.000 x 1.000 D (order by ft)	6ft
94		191 897	BRACKET, mtg unit	4
95		218 086	BRACKET, hold down fuel tank	1
96		200 864	LABEL, warning do not weld on base (Wordless Label)	2
97		Deleted		
98	R2	c _c 189 699	RESISTOR, WW tap 375W 10 ohm w/mtg bkt	1
99	R3	189 699	RESISTOR, WW tap 375W 10 ohm w/mtg bkt	1
100	Figure 13-2, Figure 13-3		CONTROL BOX ASSEMBLY	1
101		189 731	FIREWALL, lower	1
102	Figure 13-7		MAIN RECTIFIER ASSEMBLY	1
103		191 448	TOP, cover front upright	1
103		♦199 305	TOP, cover front upright ss	1
104		+201 750	UPRIGHT, front	1
104		♦+202 637	UPRIGHT, front ss	1
105		134 792	LABEL, warning general precautionary	1
105		176 105	LABEL, warning general precautionary (Wordless Label)	1
106	Figure 13-4, Figure 13-5		PANEL, front w/components	1
107		202130	XFMR, current sensing	1
108		c _v 193 453	BRACKET, mtg box fcr	1
109	PC1	c _v 189 143	MODULE, field current regulator	1
110		+147 923	LABEL, warning moving parts can cause serious injury	1
111		212 944	LABEL, cc stick overlap weld ranges	1
		190 058	NUT, .250-20 u-nut multi-thread	19
		049 525	NUT, 312-18 u-nut multi-thread	32
		192 505	KIT, label (includes safety and informational labels)	1
		201 062	KIT, label (includes safety and informational labels) (Wordless Labels)	1

+ When ordering a component originally displaying a precautionary label, the label should also be ordered. Order label individually or as part of Label Kit 192 505 or Label Kit 201 062 (Wordless Labels).

* Recommended Spare Parts.

c_c CC models only.

c_v CC/CV models only.

♦ Optional

To maintain the factory original performance of your equipment, use only Manufacturer's Suggested Replacement Parts. Model and serial number required when ordering parts from your local distributor.

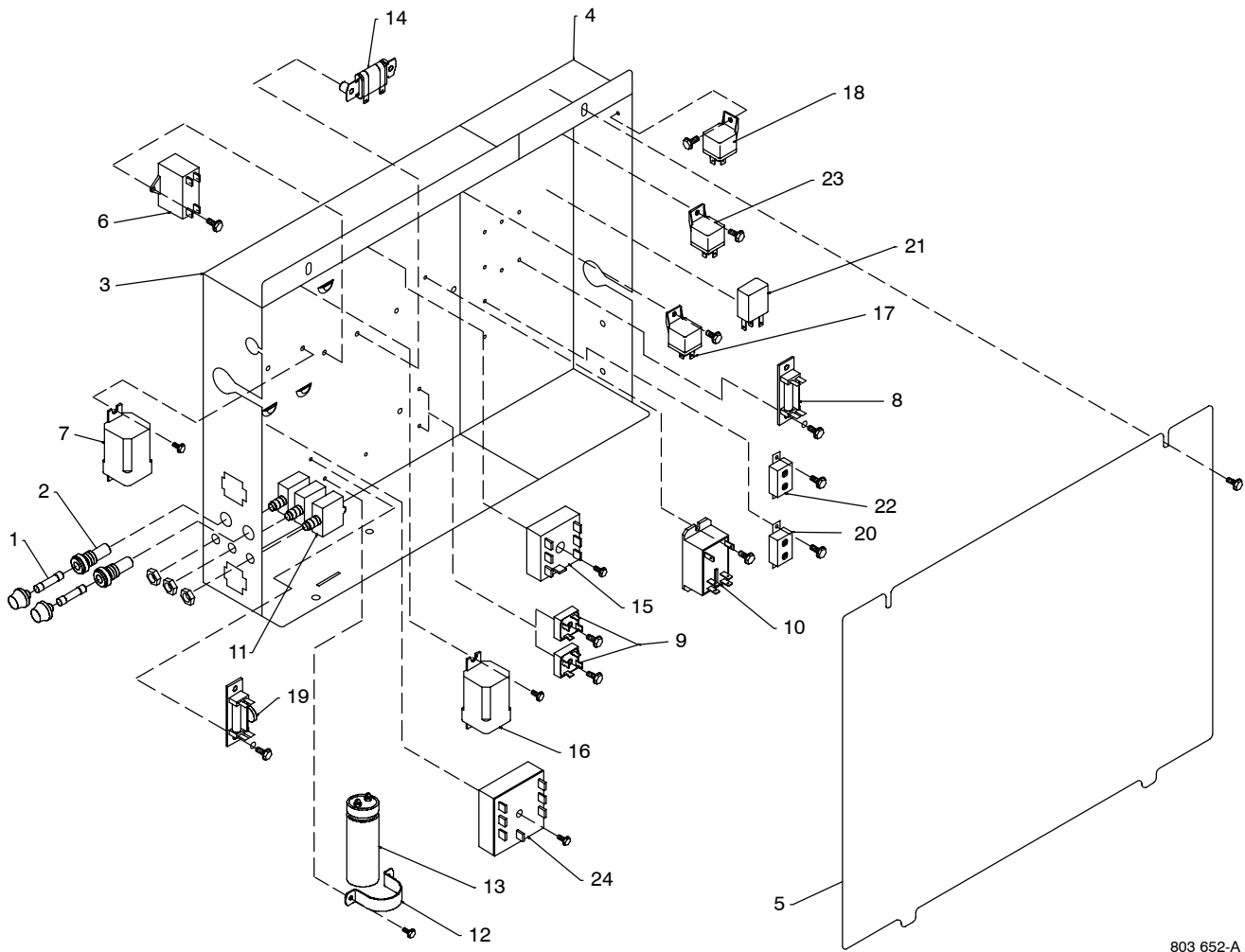

803 652-A

Figure 13-2. Control Box Assembly – CC Models

Item No.	Dia. Mkgs.	Part No.	Description	Quantity
----------	------------	----------	-------------	----------

Figure 13-2. Control Box Assembly – CC Models (Figure 13-1 Item 100)

...	1	F1, F2	*085 874	FUSE, mintr cer slo-blo 10A 250V	2
...	2		046 432	HOLDER, fuse mintr .250 x 1.250	2
...	3		201 077	CONTROL BOX, lh	1
...	4		201 078	CONTROL BOX, rh	1
...	5		201 079	COVER, control box	1
...	6	C12	191 944	CAPACITOR, polyp met film 10. uf 250 vac 10%	1
...			215 054	HARNESS, control box, weld control (consisting of)	1
...	7	CR7	188 636	RELAY, OCV control	1
...	8	D8/C8	189 701	DIODE/CAPACITOR BOARD	1
...	9	SR1, SR2	035 704	RECTIFIER, integ 40A 800V	2
...	10	CR5	199 999	RELAY, encl 12VDC SPST 30A/15VDC	1
...		S5	011 609	SWITCH, tgl spdt 15a 125vac on–none–on spd term chr (located on front panel, see Figure 13-4)	1
...		S6	011 622	SWITCH, tgl 3pdt 15a 125vac on–none–on spd term (located on front panel, see Figure 13-4)	1
...		RC4	047 483	CONNECTOR, rect univ 084 15P/S 3 row rcpt cable/panel lkg	1
...		RC3	158 466	CONNECTOR, rect univ 084 12P/S 3 row rcpt cable/panel lkg	1
...		RC1	135 133	CONNECTOR, rect univ 084 9P/S 3 row rcpt cable/panel lkg	1
...			148 850	SOCKET, relay 5 pin	1
...			177 859	CONN, body 5 terminal (to engine control switch S1)	1
...			150 316	CONN, rect univ 039 6p/s 3row plug cable lkg	5
...			092 670	CONN, rect univ 084 3p/s 1row plug cable lkg	1
...	11	CB11, 12, 13	139 266	CIRCUIT BREAKER, man reset 1P 15A 250VAC frict	3

Item No.	Dia. Mkgs.	Part No.	Description	Quantity
----------	------------	----------	-------------	----------

Figure 13-2. Control Box Assembly – CC Models (Continued)

.....		190 260	.. HARNESS, unit weld control (consisting of)	1
.....	PLG3	158 465	... CONN, rect univ 084 12p/s 3row plug cable lkg	1
.....		187 654	... SEAL, wire univ 12p/s 3row	1
.....	PLG6	114 063	... CONN, rect univ 084 4p/s 1row plug cable lkg	1
.....		192 309	... CLIP, snap in .630 bundle .250 hole .248 thk	2
... 12		177 136	.. CLAMP, capacitor 1.375dia	1
... 13	C9	087 110	.. CAPACITOR, elctlt 240uf 200VDC	1
... 14	R6	141 424	.. RESISTOR, ww fxd 30 w 25 ohm faston te	1
... 15	PC7	◆195 706	.. MODULE, pull to idle, two output, 7 pin	1
... 16	CR4	◆113 247	.. RELAY, encl 12vdc dpdt 20a/120vac 8pin flange mtg	1
... 17	CR6	◆090104	.. RELAY, encl 12vdc spst 30a/15vdc 5pin flange mtg	1
... 18	CR3	◆090 104	.. RELAY, encl 12VDC SPST 30A/15VDC spin flange mtg	1
.....		206 024	.. HARNESS, engine control (consisting of)	1
... 19	D1/C1	189 701	... DIODE/CAPACITOR BOARD	1
... 20	CB10	190 374	... CIRCUIT BREAKER, auto reset 12VDC 40A	1
.....		148 850	... SOCKET, relay 5 pin	2
.....	PLG4	114 062	... CONNECTOR, rect univ 084 15P/S 3 row plug cable lkg	1
.....		173 916	... HOUSING, contact 10-pole	1
... 21	CR1	214 876	... RELAY, encl 6vds spst 35a/14vdc 5 pin	1
... 22	CB14	◆205 927	.. CIRCUIT BREAKER, auto reset 12vdc 12 amp	1
... 23	CR8	◆197 325	.. RELAY, encl 12vdc spst 70a 4pin flange mtg	1
... 24	TD1	214 928	.. TIMER, delay on make/break open 30 sec 12vdc	1

◆Optional *Recommended Spare Parts.

To maintain the factory original performance of your equipment, use only Manufacturer's Suggested Replacement Parts. Model and serial number required when ordering parts from your local distributor.

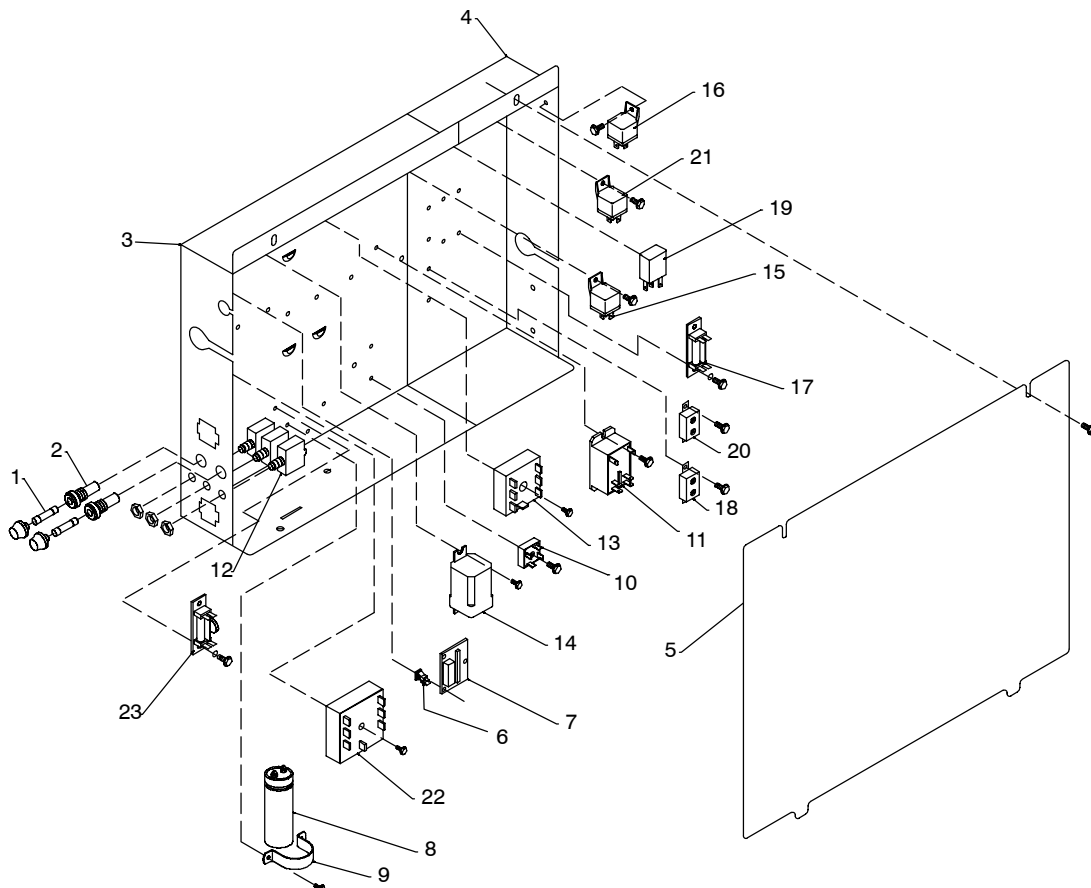

803 653-A

Figure 13-3. Control Box Assembly – CC/CV Models

Item No.	Dia. Mkgs.	Part No.	Description	Quantity
Figure 13-3. Control Box Assembly – CC/CV Models (Figure 13-1 Item 100)				
...	1 ...	F1, F2 ..	*085 874 .. FUSE, mintr cer slo-blo 10A 250V	2
...	2	046 432 ..	HOLDER, fuse mintr .250 x 1.250	2
...	3	201 077 ..	CONTROL BOX, lh	1
...	4	201 078 ..	CONTROL BOX, rh	1
...	5	201 079 ..	COVER, control box	1
...	6	134 201 ..	STAND-OFF, support pc card	3
...	7	PC9 ... 192 224 ..	CIRCUIT CARD ASSY, display	1
...	8	C9 087 110 ..	CAPACITOR, elctlt 240uf 200VDC	1
...	9	177 136 ..	CLAMP, capacitor 1.375dia	1
...	10	SR1 ... 035 704	HARNESS, control box, cv weld control (consisting of)	1
...	11	CR5 ... 199 999	RECTIFIER, integ 40A 800V	1
...	...	RC4 ... 047 483	RELAY, encl 12vdc dpst-no 30a 6pin flange	1
...	...	RC3 ... 158 466	CONNECTOR, rect univ 084 15P/S 3 row rcpt cable/panel lkg	1
...	...	RC1 ... 135 133	CONNECTOR, rect univ 084 12P/S 3 row rcpt cable/panel lkg	1
...	12	CB11, 12, 13 139 266	CONNECTOR, rect univ 084 9P/S 3 row rcpt cable/panel lkg	1
...	...	148 850	CIRCUIT BREAKER, man reset 1P 15A 250VAC frict	3
...	...	S6 193 324	SOCKET, relay 5 pin	1
...	...	S5 011 609	SWITCH, rotary 6 position gold contacts (located on front panel, see Figure 13-5)	1
...	...	150 316	SWITCH,tgl spdt 15a 125vac on-none-on spd term chr (located on front panel, see Figure 13-5)	1
...	...	177 859	CONN, rect univ 039 6p/s 3row plug cable lkg	5
...	...	193 183	CONN, body 5 terminal (to engine control switch S1)	1
...	...	196 602	CONN, rect cinch 18 pin	1
...	...	196 603	PLUG, cavity 18,30 position cinch connector	4
...	...	141 450	SEAL, switch 6 position rotary .250 shaft	1
...	13	PC7 .. ♦195 706 ..	CONN, rect metrmate 10skt 1row plug cable lkg	1
...	14	CR4 .. ♦113 247 ..	MODULE, pull to idle, two output, 7 pin	1
...	15	CR6 .. ♦090104 ..	RELAY, encl 12vdc dpdt 20a/120vac 8pin flange mtg	1
...	16	CR3 .. ♦090 104 ..	RELAY, encl 12vdc spst 30a/15vdc 5pin flange mtg	1
...	...	215 659 ..	RELAY, encl 12VDC SPST 30A/15VDC spin flange mtg	1
...	17	D8/C8 .. 189 701	HARNESS, engine control (consisting of)	1
...	18	CB10 ... 190 374	DIODE/CAPACITOR BOARD	1
...	...	148 850	CIRCUIT BREAKER, auto reset 12VDC 40A	1
...	...	PLG4 114 062	SOCKET, relay 5 pin	2
...	...	185 655	CONNECTOR, rect univ 084 15P/S 3 row plug cable lkg	1
...	19	CR1 ... 214 876	SEAL, wire univ 15P/S 3 row	1
...	20	CB14 .. ♦205 927 ..	RELAY, encl 6vds spst 35a/14vdc 5 pin	1
...	21	CR8 .. ♦197 325 ..	CIRCUIT BREAKER, auto reset 12vdc 12 amp	1
...	22	TD1 ... 214 928 ..	RELAY, ENCL 12VDC SPST 70A 4PIN FLANGE MTG	1
...	23	D1/C1 .. 189 701 ..	TIMER, delay on make/break open 30 sec 12vdc	1
...	...		DIODE/CAPACITOR BOARD	1

♦ Optional

*Recommended Spare Parts.

To maintain the factory original performance of your equipment, use only Manufacturer's Suggested Replacement Parts. Model and serial number required when ordering parts from your local distributor.

☞ Hardware is common and not available unless listed.

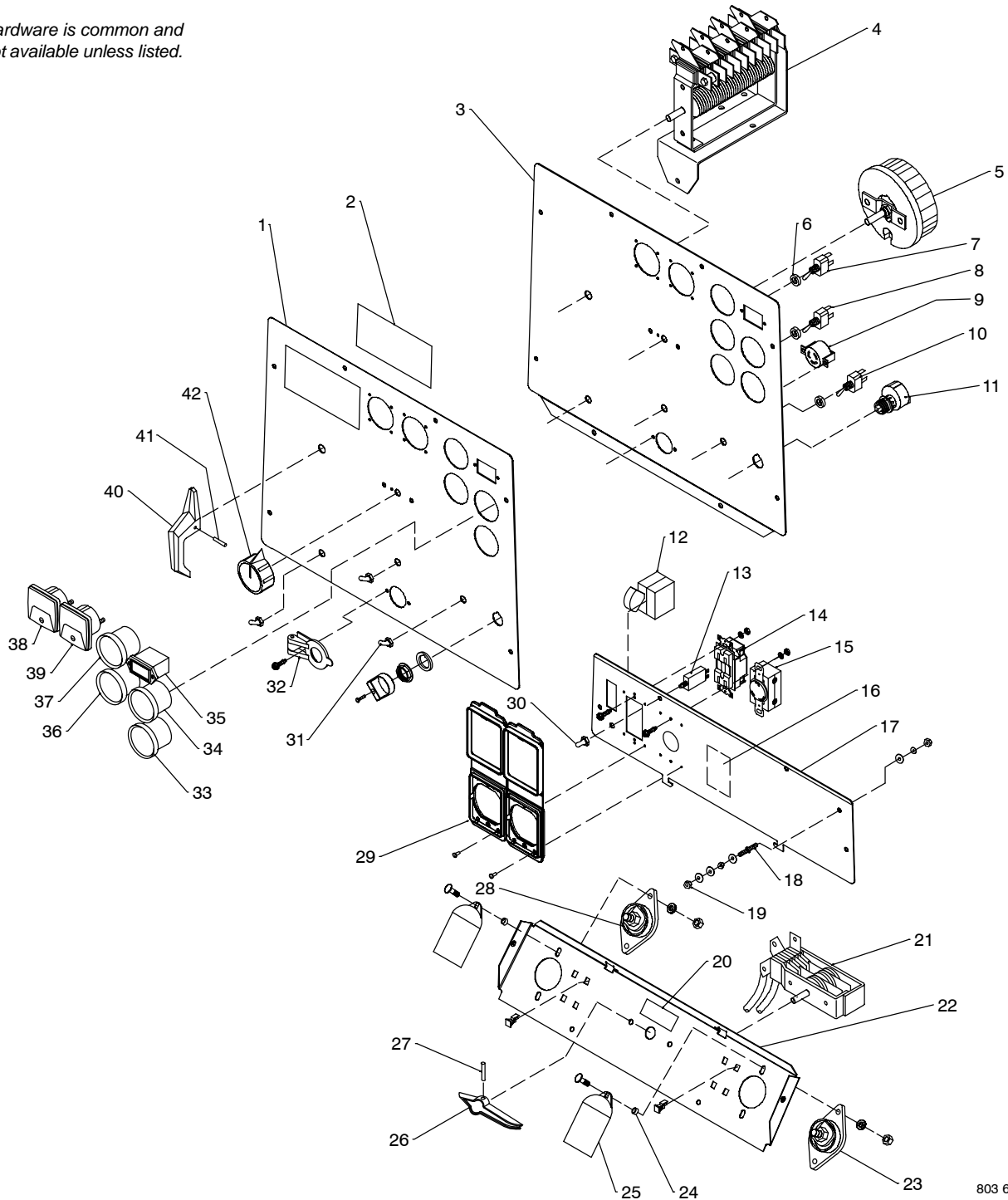

803 654-A

Figure 13-4. Panel, Front w/Components – CC Models

Item No.	Dia. Mkgs.	Part No.	Description	Quantity
...	1	215 070	PLATE SCREENED, ident control rating; when ordering this item, the nameplate should also be ordered)	1
...	2		NAMEPLATE, screened (order by model and serial number)	1
...	3	215 014	PANEL, engine/weld control	1
...	3	◆220544	PANEL, engine/weld control ss	1
...	4	S3 208278	SWITCH, range/changeover	1

Item No.	Dia. Mkgs.	Part No.	Description	Quantity
Figure 13-4. Panel, Front w/Components – CC Models (Continued)				
		192 558	HARNESSE, range (consisting of)	1
	RC6	148 439	HOUSING, rect univ 084 4p/s 1 row rcpt	1
5	R1	188 635	RHEOSTAT, WW 300W 34 ohm	1
6		202 209	SPACER, nylon	3
7	S6	011 622	SWITCH, tgl DPDT 15A 125VAC (included in control box harness, see Figure 13-2)	1
8	S5	011 609	SWITCH, tgl SPDT 15A 125VAC on-none-on spd term chr (included in control box harness, see Figure 13-2)	1
9	RC13	032 897	RECEPTACLE, twlk grd 2P3W 15A 125V	1
10	S2	021 467	SWITCH, tgl spst 3a 250v off–none–(on) spd term	1
11	S1	212 436	SWITCH, ignition 4posn w/handle	1
		201 553	CLIP, circuit breaker retaining	1
12	CB1	201 083	CIRCUIT BREAKER, man reset 2P 20 A, 250VAC	1
		201 109	HARNESSE, generatori power (consisting of)	1
13	CB2	093 996	CIRCUIT BREAKER, man reset 1P 20A 250VAC frict	3
14	GFCI1	151 981	RECEPTACLE, str dx grd 2P3W 15/20A 125V GFCI	1
15	RC1	147 632	RECEPTACLE, tw lk grd 2P3W 30A 250V L6-30R	1
16		200 910	LABEL, warning electric shock and moving parts (Wordless Label)	1
17		+215 347	PANEL, gen pwr	1
17		◆+215 045	PANEL, gen pwr ss	1
18		083 030	STUD, brs .250–20 x 1.750 w/hex collar	1
19		601 836	NUT, 250–20 .50hex .19h brs	3
20		◆196 073	LABEL, do not switch while welding	1
21	S12	◆195 825	SWITCH, polarity	1
21	S12	◆220491	SWITCH, polarity/ac	1
22		201 125	PANEL, mtg terminal pwr output	1
22		◆199 303	PANEL, mtg terminal pwr output ss	1
23		039 046	TERMINAL, pwr output black	1
		180 735	WASHER, output stud	2
24		181 169	SPACER, output stud	2
25		186 621	BOOT, generic output stud	2
26		◆059 773	HANDLE, switch	1
27		◆010 647	PIN, spring cs .156 x 1.250	1
28		039 047	TERMINAL, pwr output red	1
29		209 056	COVER, receptacle w/gasket	2
30		206 795	BOOT, circuit breaker clear hex nut	1
31		021 385	BOOT, toggle switch lever	1
32		201 045	COVER, receptacle twistlock	1
33		◆193 228	METER, Volt Dc 8– 18 Scale 2.250 In Black Face	1
34	FUEL	192 265	GAUGE, fuel elec switch w/o sensor	1
35	HM	210 424	METER, hour 12-24VDC 2.25dia	1
36		217 084	GAUGE, Coolant Temp 0– 300 Deg F	1
		195 746	SENDER, coolant temp & 130c switch	1
37		217 083	GAUGE, Pressure Oil 0–100 Psi	1
		195 745	SWITCH, pressure oil 1.5 bar nc cont	1
38		◆164 873	VOLT METER, W/Leads	1
39		◆164 874	AMMETER, W/Leads	1
40		189 161	HANDLE, switch range	1
41		010 647	PIN, spring CS .156 x 1.250	1
42		019 602	KNOB, pointer	1
		024 103	BLANK, snap–in nyl .750 mtg hole black	1

◆Optional

+ When ordering a component originally displaying a precautionary label, the label should also be ordered. Order label individually or as part of Label Kit 192 505 or Label Kit 201 062 (Wordless Labels).

To maintain the factory original performance of your equipment, use only Manufacturer's Suggested Replacement Parts. Model and serial number required when ordering parts from your local distributor.

☞ Hardware is common and not available unless listed.

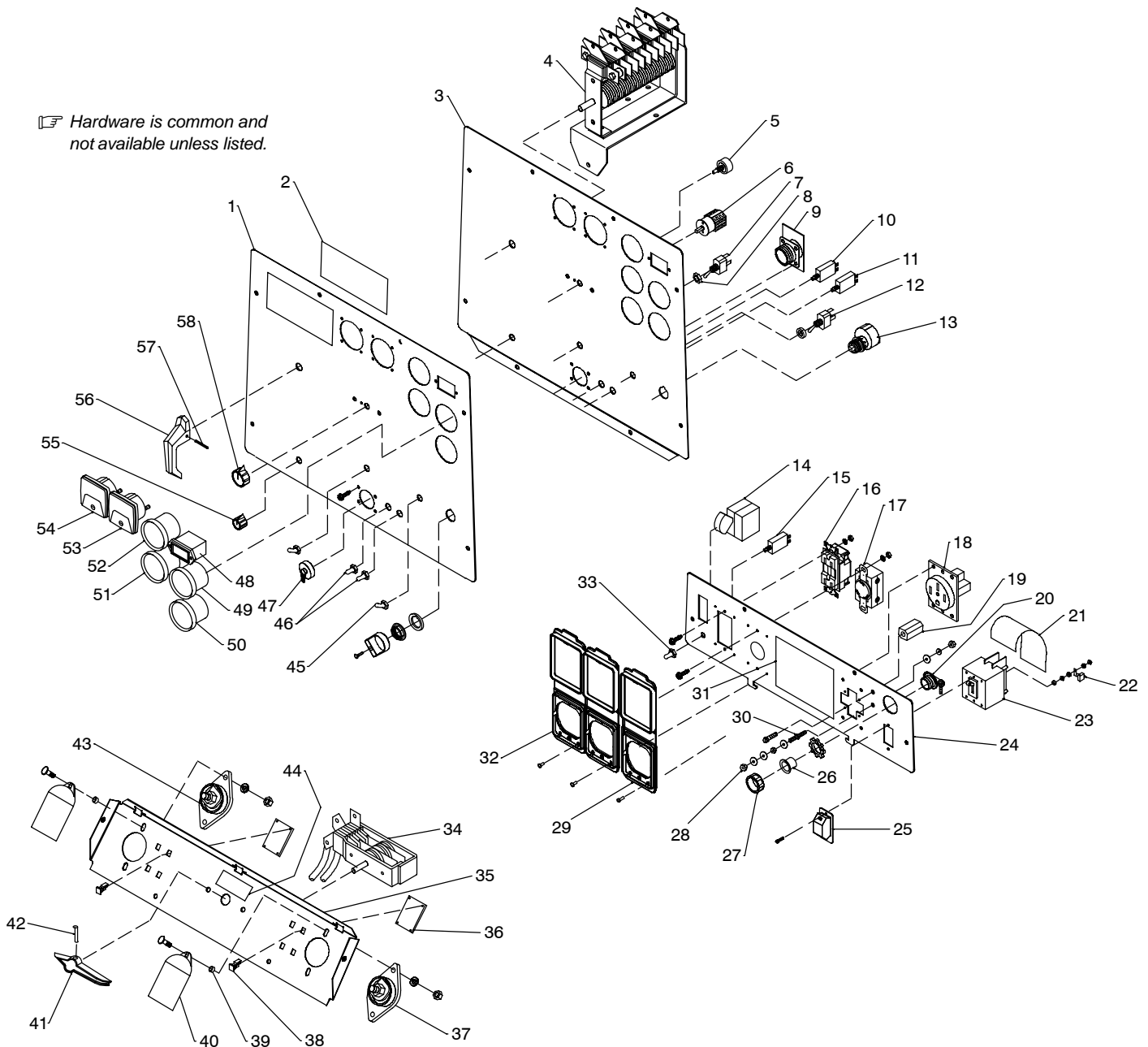

803 655-A

Figure 13-5. Panel, Front w/Components – CC/CV Models

Item No.	Dia. Mkgs.	Part No.	Description	Quantity
----------	------------	----------	-------------	----------

Figure 13-5. Panel, Front w/Components – CC/CV Models (Figure 13-1 Item 106)

...	1	215 158	.. PLATE SCREENED, ident control; when ordering this item, the nameplate should also be ordered)	1
...	2		.. NAMEPLATE, screened (order by model and serial number)	1
...	3	215014	.. PANEL, engine/weld control	1
...	3	◆220544	.. PANEL, engine/weld control ss	1
...	4	S3 208278	.. SWITCH, range/changeover	1

Item No.	Dia. Mkgs.	Part No.	Description	Quantity
Figure 13-5. Panel, Front w/Components – CC/CV Models (Continued)				
		192 558	HARNESSES, range (consisting of)	1
	RC6	148 439	HOUSING, rect univ 084 4p/s 1 row rcpt	1
5	R1	193 118	POT, cp flat 1t 2w 1k ohm linear	1
6	S6	193 234	SWITCH, rotary 6 position gold contacts (included in control box harness, see Figure 13-3)	1
7	S5	011 609	SWITCH, tgl SPDT 15A 125VAC on-none-on spd term chr (included in control box harness, see Figure 13-3)	1
8		202 209	SPACER, nylon	2
9	PC6	192 995	CIRCUIT CARD ASSY, connector/receptacle	1
10	CB5	139 266	CIRCUIT BREAKER, man reset 1p 15a 250vac frict	1
11	CB6	083 432	CIRCUIT BREAKER, Man Reset 1p 10a 250vac Frict	1
12	S2	021 467	SWITCH, tgl spst 3a 250v off–none–(on) spd term	1
13	S1	212 436	SWITCH, ignition 4 position w/handle	1
14	CB1	201 083	CIRCUIT BREAKER, man reset 2P 20 A, 250VAC	1
		201 553	CLIP, circuit breaker retaining	1
		201 109	HARNESSES, generator power (consisting of)	1
15	CB2	093 996	CIRCUIT BREAKER, man reset 1P 20A 250VAC frict	1
16	GFCI1	151 981	RECEPTACLE, str dx grd 2P3W 15/20A 125V GFCI	1
17	RC1	147 632	RECEPTACLE, tw lk grd 2P3W 30A 250V L6-30R	1
18	RC5	◆182 954	RCPT, str 3P4W 50A 125/250V	1
19		◆025 248	STAND-OFF, insul .250-20 x 1.2	1
20		◆604 102	CONNECTOR, clamp cable 1.000	1
21		◆197 527	GUARD, circuit breaker	1
22		◆197 363	TERMINAL, ring tng screw clamp	3
23	CB7	◆214 926	CIRCUIT BREAKER, man reset 3p	1
24		+215 347	PANEL, generator power	1
24		+◆215 363	PANEL, generator power (full kVA option)	1
25		◆214 927	BOOT, circuit breaker 3 pole	1
26		◆197 508	PLUG, protective	1
27		◆077 440	BUSHING, conduit 1 in	1
28		601 836	NUT, 250–20 .50hex .19h brs	3
29		◆209 056	COVER, receptacle w/gasket	1
30		083 030	STUD, brs .250–20 x 1.750 w/hex collar	1
	CT2	◆197 433	TRANSFORMER, current sensing	1
31		190 861	LABEL, warning electric shock and moving parts	1
31		◆197 399	LABEL, warning 3 ph generator power	1
32		209 056	COVER, receptacle w/gasket	2
33		206 795	BOOT, circuit breaker clear hex nut	1
34	S12	◆195 825	SWITCH, polarity	1
	S12	◆220491	SWITCH, polarity/AC	1
35		201 125	PANEL, mtg terminal pwr output	1
36	PC4, PC5	189 744	CIRCUIT CARD ASSEMBLY, filter hf	2
37		039 046	TERMINAL, pwr output black	1
		180 735	WASHER, output stud	2
38		134 201	STAND-OFF, support	12
39		181 169	SPACER, output stud	2
40		186 621	BOOT, generic output stud	2
41		◆059 773	HANDLE, switch	1
42		◆010 647	PIN, spring cs .156 x 1.250	1
43		039 047	TERMINAL, pwr output red	1
44		◆196 073	LABEL, do not switch while welding	1
45		021 385	BOOT, toggle switch lever	1
46		190 323	BOOT, circuit breaker clear hex nut	2
47		170 391	CONN, circ ms protective cap size 20	1
48	HM	210 424	METER, hour 12-24VDC 2.25dia	1
49	FUEL	192 265	GAUGE, fuel elec switch w/o sensor	1
50		◆193 228	METER, Volt Dc 8– 18 Scale 2.250 In Black Face	1

Item No.	Dia. Mkgs.	Part No.	Description	Quantity
----------	------------	----------	-------------	----------

Figure 13-5. Panel, Front w/Components – CC/CV Models (Continued)

... 51		217 084	.. GAUGE, Coolant Temp 0– 300 Deg F Electric Switch	1
...		195 746	.. SENDER, coolant temp & 130c switch	1
... 52		217 083	.. GAUGE, Pressure Oil 0–100 Psi Electric Switch	1
...		195 745	.. SWITCH, pressure oil 1.5 bar nc cont	1
... 53		◆164 873	.. VOLT METER, W/Leads	1
... 54		◆164 874	.. AMMETER, W/Leads	1
... 55		097 922	.. KNOB, pointer .875 dia x .250 ID w/set screws plstc	1
... 56		189 161	.. HANDLE, switch range	1
... 57		010 647	.. PIN, spring CS .156 x 1.250	1
... 58		097 924	.. KNOB, pointer 1.625 dia x .250 ID w/set scrws plstc	1
...		215 207	.. HARNESS, unit weld control – CV (consisting of)	1
.....	PLG6	114 063	.. CONNECTOR, rect univ 084 4p/s 1 row plug cable lkg	1
.....	PLG8	193 184	.. CONNECTOR, rect cinch 30 pin	1
.....	PLG13	147 992	.. CONNECTOR, rect univ 039 10p/s 2 row plug cable	1
.....	PLG3	158 465	.. CONNECTOR, rect univ 084 12p/s 3 row plug cable	1
.....		088 731	.. BUSHING, snap-in nyl .375 ID x .500 mtg hole	1
.....		135 873	.. CLIP, conduit convoluted 1/2 in mtg hole	2
.....		187 654	.. SEAL, wire univ 12p/s 3 row	1
.....		024 103	.. BLANK, snap-in nyl .750 mtg hole blk	1
.....		120 304	.. BLANK, snap-in nyl .250 mtg hole black	2

◆Optional

+ When ordering a component originally displaying a precautionary label, the label should also be ordered. Order label individually or as part of Label Kit 192 505 or Label Kit 201 062 (Wordless Labels).

To maintain the factory original performance of your equipment, use only Manufacturer’s Suggested Replacement Parts. Model and serial number required when ordering parts from your local distributor.

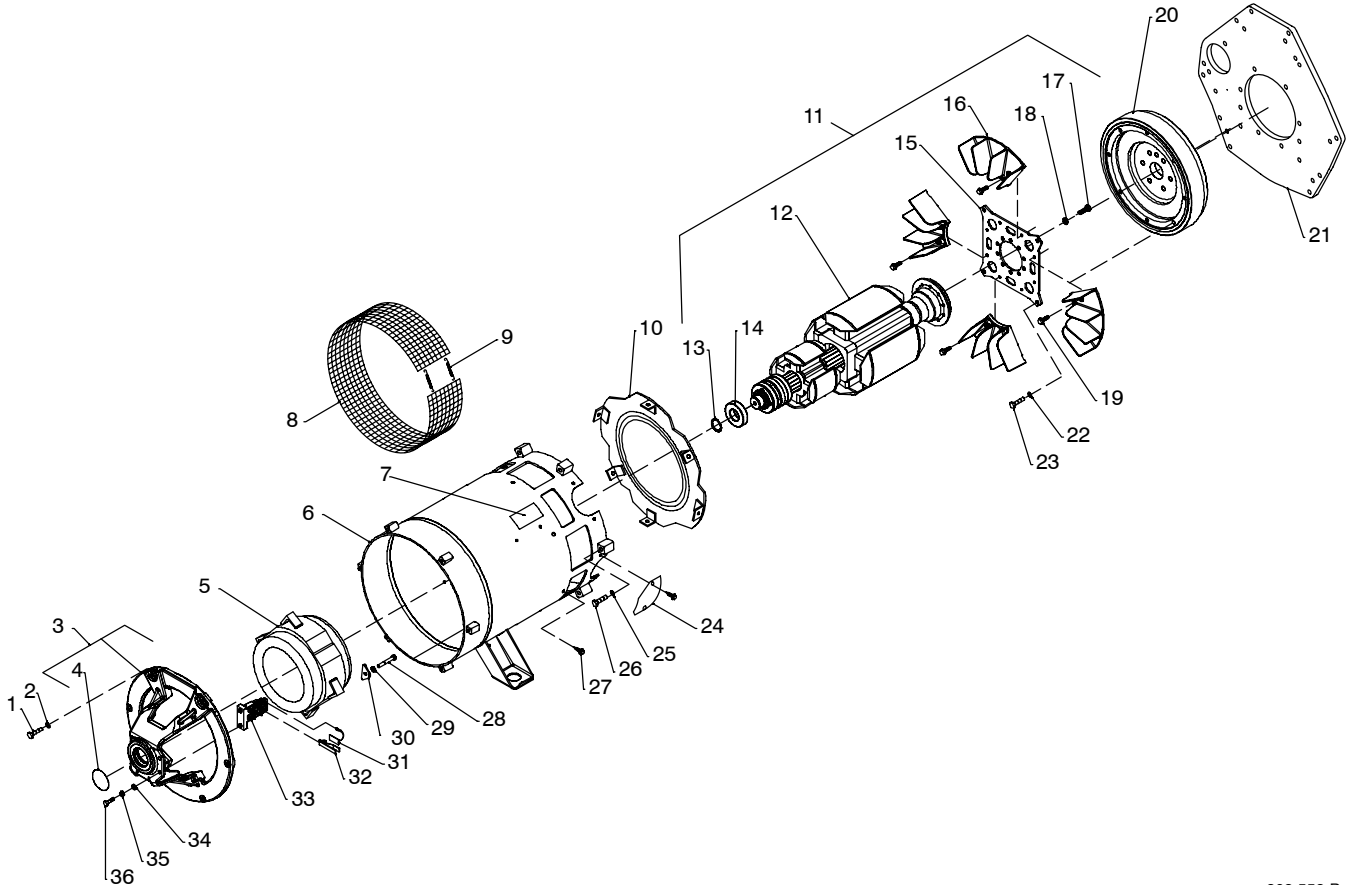

802 552-B

Figure 13-6. Generator

Item No.	Dia. Mkgs.	Part No.	Description	Quantity
Figure 13-6. Generator (Figure 13-1 Item 33)				
...	1	132 053	.. SCREW, .375-16x1.50 hex hd-pln gr5 pld	6
...	2	183 387	.. WASHER, conical spring .406 ID x .875 OD pltd	6
...	3	195 911	.. ENDBELL, gen (consisting of)	1
...	4	143 220	.. O-RING, 2.859 ID x .139CS	1
...	5	201 099	.. STATOR, exciter/gen pwr	1
...	6	+215 011	.. STATOR, weld assembly complete	1
...	6	+♦216 318	.. STATOR, weld assembly complete (full kVA option)	1
...	7	176 106	.. LABEL, warning moving parts (export models)	2
...	8	190 197	.. GUARD, generator wire mesh	1
...	9	172 674	.. SPRING, ext .240 OD x .041 wire x 3.500pld	2
...	10	039 207	.. BAFFLE, air	1
...	11	ROTOR .. 212 996	.. ROTOR, Generator Segmented Assy (Includes)	1
...	12	210 824	.. ROTOR, Generator (Includes)	1
...	13	024 617	.. RING, Rtnng Ext 1.375 Shaft X .050 Thk	1
...	14	053 390	.. BEARING, Ball Rdl Sgl Row 1.370 X 2.830 X .6	1
.....			.. HUB, Drive (Not Sold Separately)	1
.....		210 447	.. FAN, Rotor Assy Generator (Segmented) (includes)	1
...	15	210 332	.. PLATE, Flex Hubmount	1
...	16	206 242	.. FAN, Rotor Segmented Assy Gen	4
...	17	049 026	.. SCREW, M10-1.5x 25 Hex Hd-pln 8.8 Pln	10
...	18	083 883	.. WASHER, Lock .402idx0.709odx.087t Stl Split10mm	10
...	19	080 389	.. SCREW, 312-18x1.00 Hexwhd.66d Stl Pld Slffmg Tap-rw	8
...	20	195 748	.. FLYWHEEL, Engine	1
...	21	193 256	.. ADAPTER, Engine	1
...	22	083 883	.. WASHER, Lock .402idx0.709odx.087t Stl Split10mm	4
...	23	049 026	.. SCREW, M10-1.5x 25 Hex Hd-pln 8.8 Pln	4
...	24	191 579	.. COVER, starter hole Perkins/Continental	1
.....		195 560	.. GUARD, starter hole deutz 912	1
...	25	083 883	.. WASHER, Lock .402idx0.709odx.087t Stl Split10mm	6
...	26	172 555	.. SCREW, M10-1.5 x 50hexhd pln 8.8pld	6
...	27	602 159	.. SCREW, .312-18x .75 hexwhd.66d stl pld slffmg tap-rw	6
...	28	601 961	.. SCREW, .312-18 x 2.25hexhd pln gr 5pld	4
...	29	602 211	.. WASHER, lock .318 ID x 0.586	6
...	30	139 341	.. WASHER, exciter	4
...	31	*190 823	.. BRUSH, contact	3
...	32	208 469	.. CLIP, spring	3
...	33	189 142	.. BRUSHHOLDER ASSEMBLY, gen	1
...	34	602 242	.. WASHER, flat .375IDx0.875odx.083t stl pld	2
...	35	602 211	.. WASHER, Lock .318idx0.586odx.078t Stl Pld Split.312	2
...	36	604 534	.. SCREW, .312-18x1.25 hex hd-pln gr5 pld	2
.....		190 259	.. HARNESS, brush (consisting of)	1
.....	PLG1	168 071	.. CONNECTOR, (kit) rect univ 084 9P/S 3 row plug cable lkg	1
.....		187 651	.. SEAL, wire univ 9P/S 3 row	1

+ When ordering a component originally displaying a precautionary label, the label should also be ordered. Order label individually or as part of Label Kit 192 505 or Label Kit 201 062 (Wordless Labels).
 *Recommended Spare Parts.

♦Optional

To maintain the factory original performance of your equipment, use only Manufacturer's Suggested Replacement Parts. Model and serial number required when ordering parts from your local distributor.

☞ Hardware is common and not available unless listed.

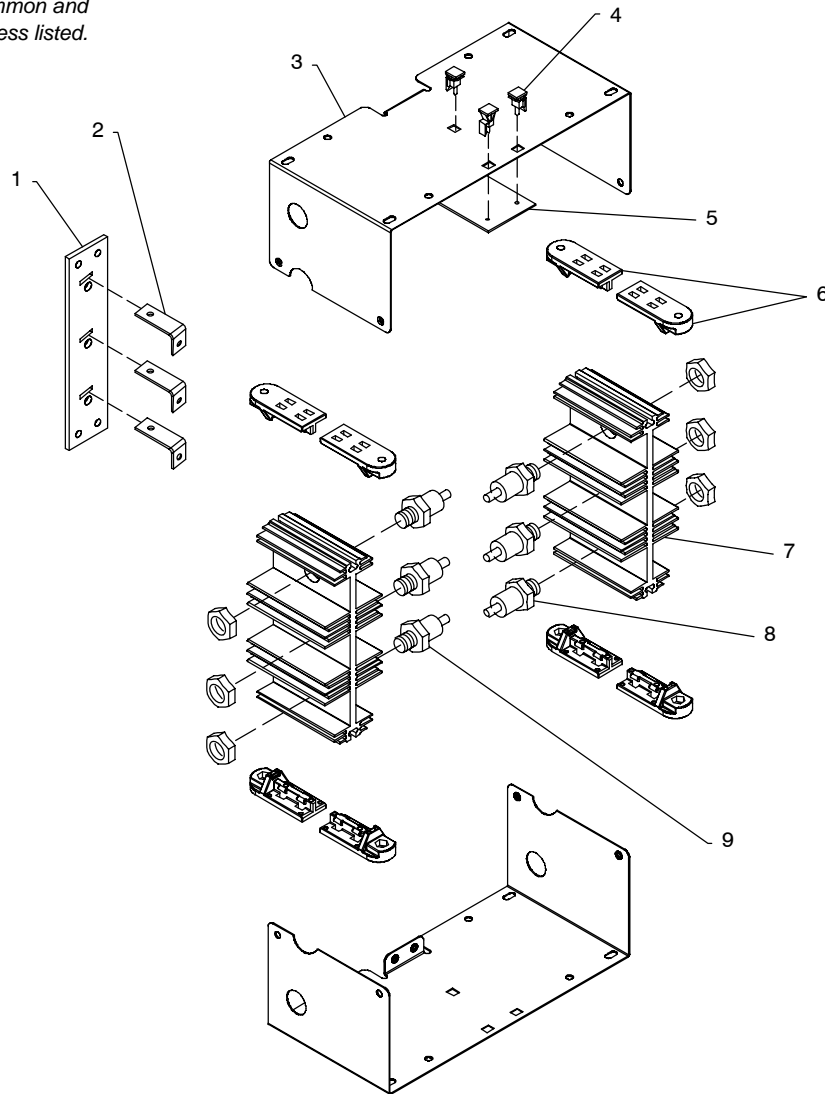

802 279-A

Figure 13-7. Main Rectifier Assembly

Item No.	Dia. Mkgs.	Part No.	Description	Quantity
----------	------------	----------	-------------	----------

Figure 13-7. Main Rectifier Assembly (Figure 13-1 Item 102)

.....	SR3	215 909	RECTIFIER (consisting of)	1
.....	SR3	◆	RECTIFIER, environmental (consisting of)	1
... 1	188 137	CONNECTION BOARD, rectifier AC	1
... 2	188 517	BUS BAR, connection board	3
... 3	188 135	ENCLOSURE, rectifier	2
... 4	134 201	STAND-OFF, support	3
... 5	PC3	215 755	CIRCUIT CARD ASSEMBLY, protection	1
... 6	188 136	INSULATOR, heat sink	8
... 7	188 493	HEAT SINK, rectifier al	2
... 8	D3, D5, D7	037 956	DIODE, rect 275A 300V SP	3
... 9	D2, D4, D6	037 957	DIODE, rect 275A 300V RP	3

To maintain the factory original performance of your equipment, use only Manufacturer's Suggested Replacement Parts. Model and serial number required when ordering parts from your local distributor.

TRUE BLUE® WARRANTY

Effective January 1, 2004

(Equipment with a serial number preface of "LE" or newer)

This limited warranty supersedes all previous Miller warranties and is exclusive with no other guarantees or warranties expressed or implied.

Warranty Questions?

Call
1-800-4-A-MILLER
for your local
Miller distributor.

Your distributor also gives
you ...

Service

You always get the fast,
reliable response you
need. Most replacement
parts can be in your
hands in 24 hours.

Support

Need fast answers to the
tough welding questions?
Contact your distributor.
The expertise of the
distributor and Miller is
there to help you, every
step of the way.

LIMITED WARRANTY - Subject to the terms and conditions below, Miller Electric Mfg. Co., Appleton, Wisconsin, warrants to its original retail purchaser that new Miller equipment sold after the effective date of this limited warranty is free of defects in material and workmanship at the time it is shipped by Miller. THIS WARRANTY IS EXPRESSLY IN LIEU OF ALL OTHER WARRANTIES, EXPRESS OR IMPLIED, INCLUDING THE WARRANTIES OF MERCHANTABILITY AND FITNESS.

Within the warranty periods listed below, Miller will repair or replace any warranted parts or components that fail due to such defects in material or workmanship. Miller must be notified in writing within thirty (30) days of such defect or failure, at which time Miller will provide instructions on the warranty claim procedures to be followed.

Miller shall honor warranty claims on warranted equipment listed below in the event of such a failure within the warranty time periods. All warranty time periods start on the date that the equipment was delivered to the original retail purchaser, or one year after the equipment is sent to a North American distributor or eighteen months after the equipment is sent to an International distributor.

1. 5 Years Parts — 3 Years Labor
 - * Original main power rectifiers
 - * Inverters (input and output rectifiers only)
2. 3 Years — Parts and Labor
 - * Transformer/Rectifier Power Sources
 - * Plasma Arc Cutting Power Sources
 - * Semi-Automatic and Automatic Wire Feeders
 - * Inverter Power Sources (Unless Otherwise Stated)
 - * Water Coolant Systems (Integrated)
 - * Intelligig
 - * Maxstar 150
 - * Engine Driven Welding Generators
(NOTE: Engines are warranted separately by the engine manufacturer.)
3. 1 Year — Parts and Labor Unless Specified
 - * DS-2 Wire Feeder
 - * Motor Driven Guns (w/exception of Spoolmate Spoolguns)
 - * Process Controllers
 - * Positioners and Controllers
 - * Automatic Motion Devices
 - * RFCS Foot Controls
 - * Induction Heating Power Sources and Coolers
 - * Water Coolant Systems (Non-Integrated)
 - * Flowgauge and Flowmeter Regulators (No Labor)
 - * HF Units
 - * Grids
 - * Maxstar 85, 140
 - * Spot Welders
 - * Load Banks
 - * Arc Stud Power Sources & Arc Stud Guns
 - * Racks
 - * Running Gear/Trailers
 - * Plasma Cutting Torches (except APT & SAF Models)
 - * Field Options
(NOTE: Field options are covered under True Blue® for the remaining warranty period of the product they are installed in, or for a minimum of one year — whichever is greater.)
4. 6 Months — Batteries
5. 90 Days — Parts
 - * MIG Guns/TIG Torches

- * Induction Heating Coils and Blankets
- * APT & SAF Model Plasma Cutting Torches
- * Remote Controls
- * Accessory Kits
- * Replacement Parts (No labor)
- * Spoolmate Spoolguns
- * Canvas Covers

Miller's True Blue® Limited Warranty shall not apply to:

1. **Consumable components; such as contact tips, cutting nozzles, contactors, brushes, slip rings, relays or parts that fail due to normal wear. (Exception: brushes, slip rings, and relays are covered on Bobcat, Trailblazer, and Legend models.)**
2. Items furnished by Miller, but manufactured by others, such as engines or trade accessories. These items are covered by the manufacturer's warranty, if any.
3. Equipment that has been modified by any party other than Miller, or equipment that has been improperly installed, improperly operated or misused based upon industry standards, or equipment which has not had reasonable and necessary maintenance, or equipment which has been used for operation outside of the specifications for the equipment.

MILLER PRODUCTS ARE INTENDED FOR PURCHASE AND USE BY COMMERCIAL/INDUSTRIAL USERS AND PERSONS TRAINED AND EXPERIENCED IN THE USE AND MAINTENANCE OF WELDING EQUIPMENT.

In the event of a warranty claim covered by this warranty, the exclusive remedies shall be, at Miller's option: (1) repair; or (2) replacement; or, where authorized in writing by Miller in appropriate cases, (3) the reasonable cost of repair or replacement at an authorized Miller service station; or (4) payment of or credit for the purchase price (less reasonable depreciation based upon actual use) upon return of the goods at customer's risk and expense. Miller's option of repair or replacement will be F.O.B., Factory at Appleton, Wisconsin, or F.O.B. at a Miller authorized service facility as determined by Miller. Therefore no compensation or reimbursement for transportation costs of any kind will be allowed.

TO THE EXTENT PERMITTED BY LAW, THE REMEDIES PROVIDED HEREIN ARE THE SOLE AND EXCLUSIVE REMEDIES. IN NO EVENT SHALL MILLER BE LIABLE FOR DIRECT, INDIRECT, SPECIAL, INCIDENTAL OR CONSEQUENTIAL DAMAGES (INCLUDING LOSS OF PROFIT), WHETHER BASED ON CONTRACT, TORT OR ANY OTHER LEGAL THEORY.

ANY EXPRESS WARRANTY NOT PROVIDED HEREIN AND ANY IMPLIED WARRANTY, GUARANTY OR REPRESENTATION AS TO PERFORMANCE, AND ANY REMEDY FOR BREACH OF CONTRACT TORT OR ANY OTHER LEGAL THEORY WHICH, BUT FOR THIS PROVISION, MIGHT ARISE BY IMPLICATION, OPERATION OF LAW, CUSTOM OF TRADE OR COURSE OF DEALING, INCLUDING ANY IMPLIED WARRANTY OF MERCHANTABILITY OR FITNESS FOR PARTICULAR PURPOSE, WITH RESPECT TO ANY AND ALL EQUIPMENT FURNISHED BY MILLER IS EXCLUDED AND DISCLAIMED BY MILLER.

Some states in the U.S.A. do not allow limitations of how long an implied warranty lasts, or the exclusion of incidental, indirect, special or consequential damages, so the above limitation or exclusion may not apply to you. This warranty provides specific legal rights, and other rights may be available, but may vary from state to state.

In Canada, legislation in some provinces provides for certain additional warranties or remedies other than as stated herein, and to the extent that they may not be waived, the limitations and exclusions set out above may not apply. This Limited Warranty provides specific legal rights, and other rights may be available, but may vary from province to province.





Owner's Record

Please complete and retain with your personal records.

Model Name

Serial/Style Number

Purchase Date

(Date which equipment was delivered to original customer.)

Distributor

Address

City

State

Zip



For Service

Call 1-800-4-A-Miller or see our website at www.MillerWelds.com to locate a DISTRIBUTOR or SERVICE AGENCY near you.

Always provide Model Name and Serial/Style Number.

Contact your Distributor for:

Welding Supplies and Consumables

Options and Accessories

Personal Safety Equipment

Service and Repair

Replacement Parts

Training (Schools, Videos, Books)

Technical Manuals (Servicing Information and Parts)

Circuit Diagrams

Welding Process Handbooks

Contact the Delivering Carrier to:

File a claim for loss or damage during shipment.

For assistance in filing or settling claims, contact your distributor and/or equipment manufacturer's Transportation Department.

Miller Electric Mfg. Co.

An Illinois Tool Works Company
1635 West Spencer Street
Appleton, WI 54914 USA

International Headquarters—USA

USA Phone: 920-735-4505 Auto-Attended
USA & Canada FAX: 920-735-4134
International FAX: 920-735-4125

European Headquarters – United Kingdom

Phone: 44 (0) 1204-593493
FAX: 44 (0) 1204-598066

www.MillerWelds.com

