

# 24 GAGE STEEL RTA WALL CABINET INSTALL INSTRUCTIONS

NEWAGE  
PRODUCTS INC.







## READ THIS FIRST BEFORE UNPACKING CABINET

**ALL CABINETS MUST BE MOUNTED TO STUDS ON A SECURE WALL, AS PER THESE INSTRUCTIONS. FAILURE TO DO SO MAY RESULT IN SERIOUS INJURY AND VOIDS PRODUCT WARRANTY AND MANUFACTURER'S LIABILITY.**

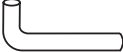
**WARNING:  
DO NOT OVERLOAD CABINETS!  
CABINETS ARE DESIGNED  
TO CARRY THE FOLLOWING  
MAXIMUM WEIGHT  
CAPACITIES:**

Cabinet	Shelf Weight Capacity (lbs)	Overall Weight Capacity
Locker	50	200
Wall	40	80
Base	50	150

## PARTS AND HARDWARE SUPPLIED WITH WALL CABINET:

QTY	ITEM	IMAGE
4	Hinge	
47	M5 Frame Screw	
47	M5 Frame Nut	
4	2.5" Wall Screw	
4	Hinge Plastic Washer	
4	Large Washer	

**DO NOT LEAVE CHILDREN UNATTENDED NEAR CABINETS.  
WHEN FULLY LOADED, CABINETS ARE HEAVY AND THERE IS A  
RISK OF CABINETS OR ITEMS TIPPING IF IMPROPERLY OPENED.**



## WARNING: EXCESSIVE WEIGHT HAZARD

- Use two or more people to move, assemble or install cabinet or locker.
- Failure to do so can result in back or other injury.

## UNPACKING OF THE CABINET:

- Begin by placing the cabinet on a sound level surface.
- Remove all cardboard and foam packaging material.
- Remove clear plastic bag.
- Dispose / recycle all packaging materials.
- Remove and verify all the contents in the box. See "Parts and Hardware Supplied List"

# 24 GAGE STEEL RTA WALL CABINET INSTALL INSTRUCTIONS

NEWAGE  
PRODUCTS INC.

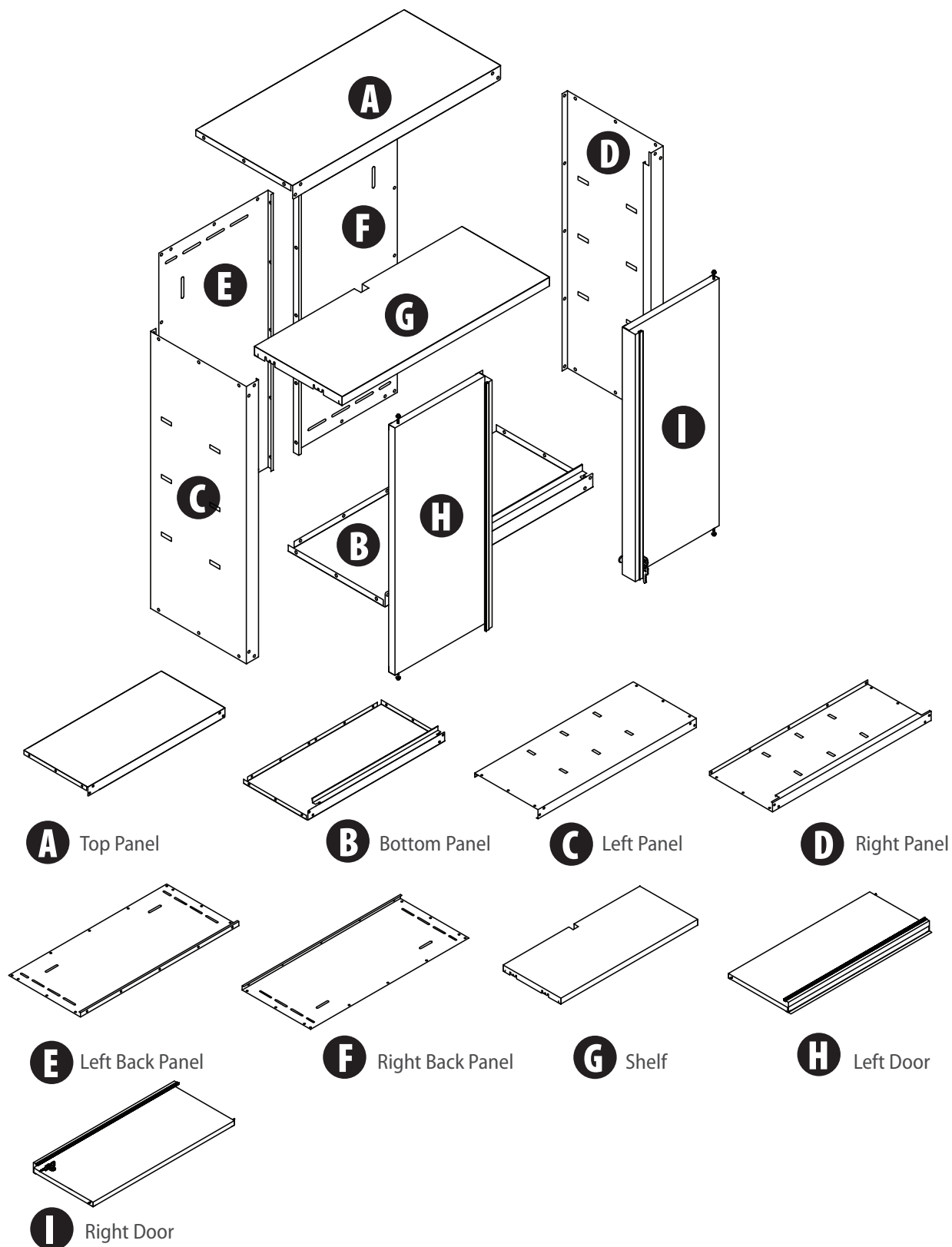

NEED MORE INFORMATION? TRY, [WWW.NEWAGEPRODUCTS.COM](http://WWW.NEWAGEPRODUCTS.COM) OR 1 877 306 8930 FOR ANSWERS TO COMMONLY ASKED QUESTIONS.

# 24 GAGE STEEL RTA WALL CABINET INSTALL INSTRUCTIONS

NEWAGE  
PRODUCTS INC.

1. Use the M5 screw and M5 nut to assemble the two back panels.

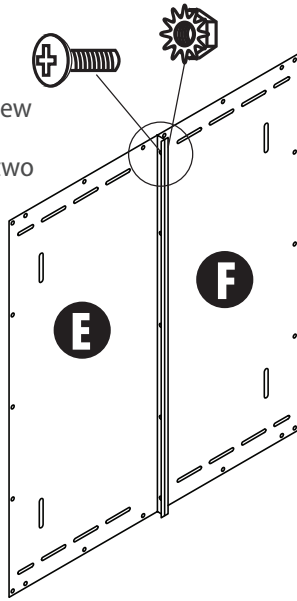

2. Assemble the left and right side panels with the same screw and nut. D goes on the outside of E, and C goes on the outside of F.

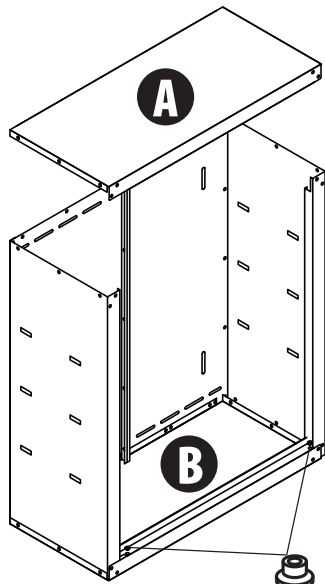
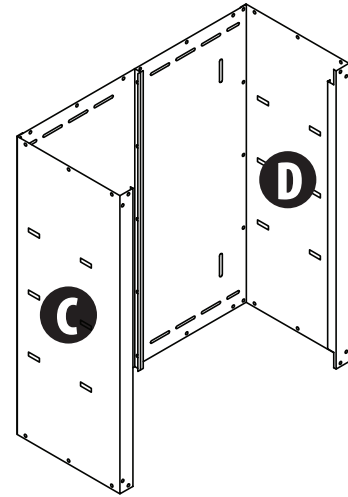
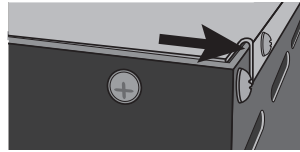

3. Panel A sits on the outside of E and F, and on the inside of C and D.

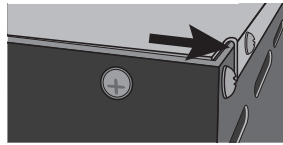

5. Insert the shelf. If shelf tabs are not catching with the inside of panels D and C, pull the shelf notches outwards.



4. Put the four plastic washers in the holes at the four corners.

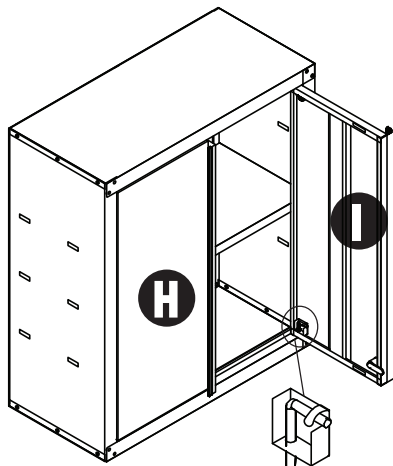

6. Assemble the right and left doors and insert the hinges into the plastic washers to attach doors. Bend down the clips to fix the hinges in place. Extra spacers are provided to ensure doors are level.

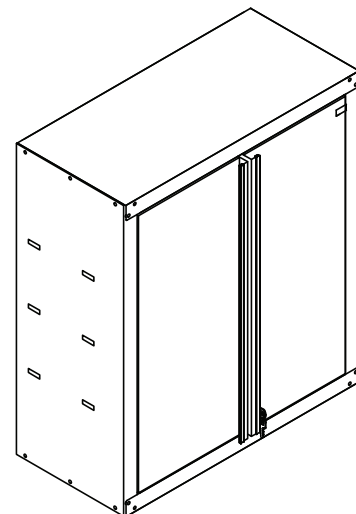

# 24 GAGE STEEL RTA WALL CABINET INSTALL INSTRUCTIONS

NEWAGE  
PRODUCTS INC.

## ASSEMBLY INSTRUCTIONS:

### INSTALLING SHELVES:

**NOTE:** Plan your shelf heights and install shelves starting from the bottom. The shelves are supported by the metal tabs on the back and side walls of the cabinet.

1. Determine the placement of the shelves.
2. Tilt the shelf so that one end is higher than the other as show in the diagram below.

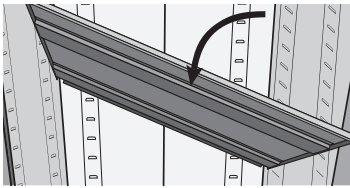

3. Insert the shelf into the cabinet so that the higher end is directly above the desired slots and push the shelf down into place behind the side walls of the cabinet.
4. Raise the lower end so it is directly above the desired slots and push the shelf down.

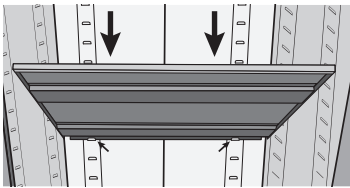

**NOTE:** Make sure all shelf tabs are completely in place, see below diagram.

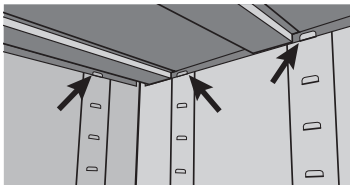

5. Repeat steps 2 – 4 for the remaining shelves.
- Note:** one shelf in the locker must be level with the lock on the door of the cabinet, in order for the lock to work.

### MOUNTING CABINETS INTO DRYWALL / STUDDED WALL: **WARNING: ALL CABINETS MUST BE MOUNTED TO STUDS BEFORE LOADING THE CABINETS WITH ITEMS**

Each locker or base cabinet must be mounted to the wall with at least two of the provided mounting screws. Each wall cabinet must be mounted with four screws.

1. Using a stud finder locate the studs in the wall where the wall cabinet is to be placed.
2. Once studs are located, using a pencil and a level mark a vertical line to indicate stud location.



3. Place the cabinet into position tight against the supporting wall.
4. Open the doors and locate the perforated mounting strip on the top and bottom of the backside of the cabinet.

**Note:** the wall cabinet has a perforated strip of holes at the top and bottom of the cabinet, the locker only has a perforated strip at the top of the cabinet.

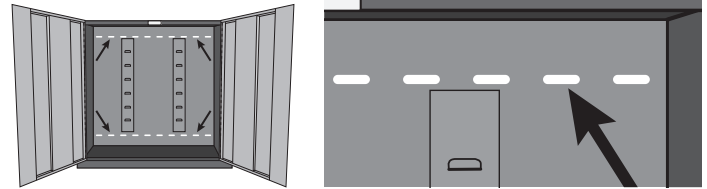

5. Align the previously marked stud lines with a perforated hole by shifting the cabinet slightly.
6. Place a small magnetic level on top of the wall cabinet and adjust the orientation of the cabinet to bring it to a level position.

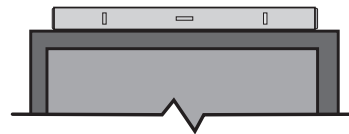

7. Once leveled, using the supplied mounting hardware fasten a 2.5" x 1/4" cabinet mounting lag bolt with a large washer through the cabinet and into the stud. This can be done by hand with a 7/16th socket wrench or a cordless power drill with a 7/16th socket attachment. Do not over tighten bolts! Once the fender is sitting tightly flush with the backside of the cabinet stop.
8. Repeat Step 6 three additional times with the remaining mounting hardware to install the wall cabinet. You will only repeat this one more time for the locker, as it only has 2 mounting lag bolts.

### WALL AND LOCKER CABINET WALL MOUNTING INTO CONCRETE BLOCK / MASONRY WALL:

**NOTE:** Masonry Hardware **NOT** Included

#### REQUIRED HARDWARE:

- 2 1/4" x 1/4" Tapcon Concrete Anchor (4)  
Or
- #10 x 2" Screw with 3/16" masonry plug (4)

1. Place the wall cabinet into position tight against the supporting wall.
2. Open the doors and locate the perforated mounting strip on the top and bottom of the backside of the cabinet.

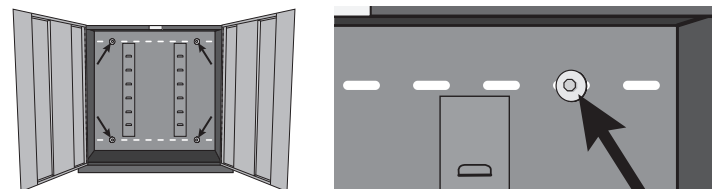

3. Place a small magnetic level on top of the wall cabinet and adjust the orientation of the cabinet to bring it to a level position.

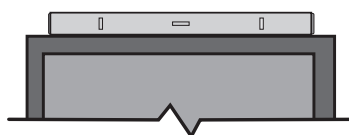

# 24 GAGE STEEL RTA WALL CABINET INSTALL INSTRUCTIONS

NEWAGE  
PRODUCTS INC.

4. Using a hammer drill, drill 4 pilot holes through the perforated strip in the backside of the cabinet and through the wall.
5. Using either the 2 ¼" x ¼" Tapcon Concrete Anchor or #10 x 2" Screw with 3/16" masonry plug method and the supplied fender washers fasten the cabinet directly to the wall. This application requires a cordless power dill with a #2 Philips bit for ease of installation.
6. Repeat Step 3 - 4 three additional times with the remaining mounting hardware.

**THANK YOU** for purchasing a Coleman product.  
Please give us a call, or visit us online if you have any other questions or comments.

Give us your feedback for a chance to WIN! Take our quick 2 minute survey and enter for your chance to win something FREE from NEWAGE! Visit the website for details at [www.newageproducts.com](http://www.newageproducts.com)

NEWAGE  
PRODUCTS INC.  
THE ORGANIZED GARAGE

201 Chrislea Road, Vaughan, ON, Canada  
1-877-306-8930  
[www.NEWAGEPRODUCTS.com](http://www.NEWAGEPRODUCTS.com)

# **NEWAGE PRODUCTS INC. STEEL CABINETS WARRANTY**

## **1 YEAR LIMITED MANUFACTURER WARRANTY**



For one year from the date of purchase, when this product is installed, operated and maintained according to the instructions attached to or furnished with the product, NewAge Products Inc. will replace the defective product or parts if the part fails as a result of defective materials or workmanship.

---

---

### **NEWAGE PRODUCTS INC. WILL NOT PAY FOR:**

1. Service calls to correct the installation of any NewAge products or to instruct you how to use or install them.
  2. Damage resulting from improper handling or shipping of products, or products damaged by accident, misuse, abuse, fire, flood, improper installation, acts of God, neglect, corrosion, modification or mishandling.
  3. Products damaged by improperly loading beyond the specified maximum weight capacity outlined in the instructions provided with the product.
  4. Repairs or replacement when your product is used in other than normal, single-family household use, such as a commercial environment, or handled in any way inconsistent with the installation instructions included with the product.
  5. Cosmetic damage, including scratches, dings, dents or cracks in paint that do not affect the structural or functional capability of the product.
  6. Surfaces damaged due to chemical interaction resulting in corrosion of paint or metal.
  7. Replacement parts for NewAge products outside Canada and the United States.
  8. Replacement keys or locking mechanisms.
  9. Loss of product contents due to theft, fire, flood, accident or acts of God.
  10. Shipping or freight fees to deliver replacement products or to return defective products.
  11. Any labor costs during the limited warranty period.
- 
- 

### **DISCLAIMER OF IMPLIED WARRANTIES; LIMITATION OF REMEDIES**

IMPLIED WARRANTIES, INCLUDING TO THE EXTENT APPLICABLE WARRANTIES OF MERCHANTABILITY OR FITNESS FOR A PARTICULAR PURPOSE, ARE EXCLUDED TO THE EXTENT LEGALLY PERMISSIBLE. ANY IMPLIED WARRANTIES THAT MAY BE IMPOSED BY LAW ARE LIMITED TO ONE YEAR, OR THE SHORTEST PERIOD ALLOWED BY LAW. SOME STATES AND PROVINCES DO NOT ALLOW LIMITATIONS OR EXCLUSIONS ON HOW LONG AN IMPLIED WARRANTY OF MERCHANTABILITY OR FITNESS LASTS, SO THE ABOVE LIMITATIONS OR EXCLUSIONS MAY NOT APPLY TO YOU. THIS WARRANTY GIVES YOU SPECIFIC LEGAL RIGHTS, AND YOU MAY ALSO HAVE OTHER RIGHTS WHICH VARY FROM STATE TO STATE OR PROVINCE TO PROVINCE