

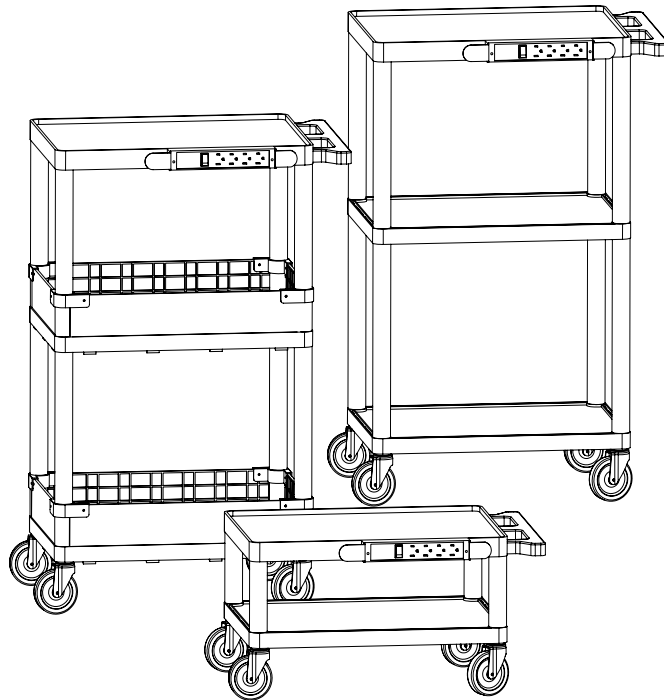









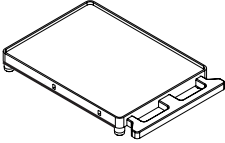



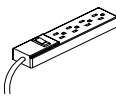
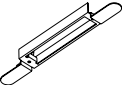



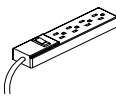
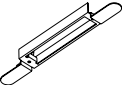

# BLT-27529 All Service Cart

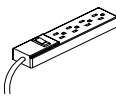
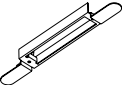

## Assembly Instructions

# #27529 All Service Cart

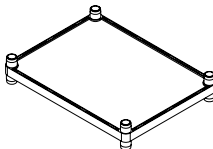
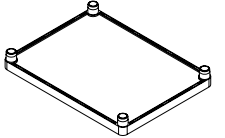
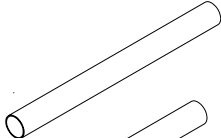
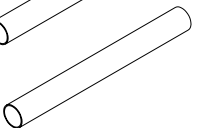
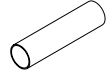
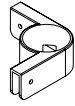
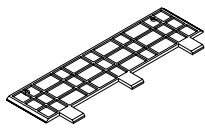
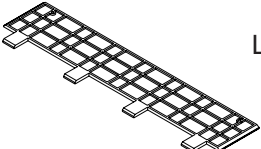
Part	Drawing	Description	Qty	Part	Drawing	Description	Qty																												
P1		Top Shelf	1 EA	<div style="border: 1px solid black; border-radius: 15px; padding: 10px; margin: 10px auto; width: 80%;"> <h3 style="text-align: center;">Hardware List</h3> <table style="width: 100%; border-collapse: collapse;"> <tr> <td style="width: 5%;">A</td> <td style="width: 10%;"></td> <td style="width: 75%;">Screw M4x16mm</td> <td style="width: 10%;">16 EA</td> </tr> <tr> <td>B</td> <td></td> <td>4" Locking Caster</td> <td>2 EA</td> </tr> <tr> <td>C</td> <td></td> <td>4" Caster</td> <td>2 EA</td> </tr> <tr> <td>EL-1</td> <td></td> <td>Electric Outlet</td> <td>1 EA</td> </tr> <tr> <td>EL-2</td> <td></td> <td>Metal Bracket w/Cord Winder</td> <td>1 EA</td> </tr> <tr> <td>EL-3</td> <td></td> <td>3" Machine Screw</td> <td>2 EA</td> </tr> <tr> <td>EL-4</td> <td></td> <td>Hex Nut</td> <td>2 EA</td> </tr> </table> <p style="text-align: center; margin-top: 10px;"><i>We recommend that you assemble this unit on a table.</i></p> <p>Tools required: Adjustable Crescent Wrench</p> </div>				A		Screw M4x16mm	16 EA	B		4" Locking Caster	2 EA	C		4" Caster	2 EA	EL-1		Electric Outlet	1 EA	EL-2		Metal Bracket w/Cord Winder	1 EA	EL-3		3" Machine Screw	2 EA	EL-4		Hex Nut	2 EA
A		Screw M4x16mm	16 EA																																
B		4" Locking Caster	2 EA																																
C		4" Caster	2 EA																																
EL-1		Electric Outlet	1 EA																																
EL-2		Metal Bracket w/Cord Winder	1 EA																																
EL-3		3" Machine Screw	2 EA																																
EL-4		Hex Nut	2 EA																																
P2		Middle Shelf	1 EA																																
P3		Bottom Shelf	1 EA																																
P4		Tube 17-1/2	4 EA																																
P5		Tube 15-1/4	4 EA																																
P6		Tube 6-1/2	4 EA																																
P-7		Collar	8 EA																																
P8		Small Fence	4 EA																																
P9		Large Fence	4 EA																																

Do not use unless all screws are tight. At least every six months, check all screws to be sure they are tight. If parts are missing, broken, damaged, or worn, stop use of the product until repairs are made by your dealer using factory authorized parts.

# #27529 All Service Cart Assembly Diagram



**READ THROUGH INSTRUCTIONS FROM BEGINNING TO END BEFORE STARTING TO ASSEMBLE UNIT.**

- 1.) Slide Metal Bracket (EL-2) over the Electrical Outlet (EL-1) as shown. (note that Metal Stop is at the end with the electrical Plug-in.)
- 2.) Attach Metal Bracket (EL-2) to the Top Shelf (P-1) using 2 3" Machine Screws (EL-3) and 2 Hex Nuts (EL-4) as shown in illustration.

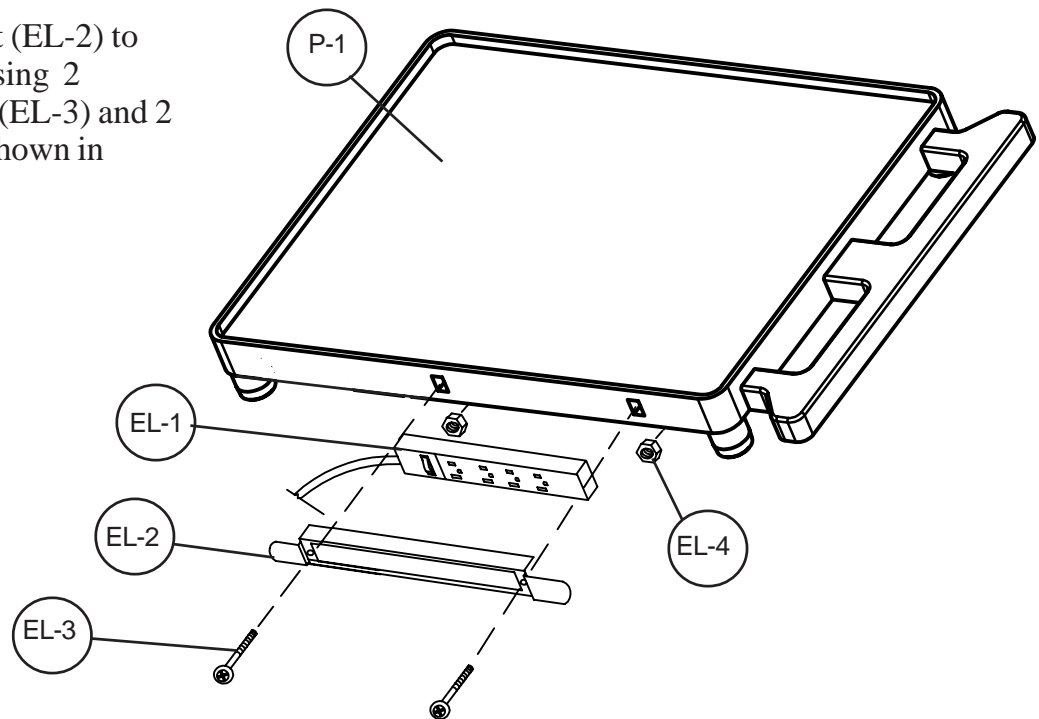

Illustration # 1

## Important

The Balt product you have purchased is guaranteed against material and workmanship defects. This guarantee extends 1 year from date of purchase. Should this product fail to function satisfactorily under normal use due to defect or imperfection, the defective part or product will be replaced. Damage caused by common carriers during shipment is not included in this guarantee.

**This guarantee sets forth all applicable guarantees and remedies. No other warranty, expressed or implied shall apply. Failure to follow instructions found in Important Information Section of Owner Sheet shall void the guarantee. Consequential or incidental damages and or costs are not refundable.**

# All Service Cart Assembly

(Without Fences)

Illustration # 2B

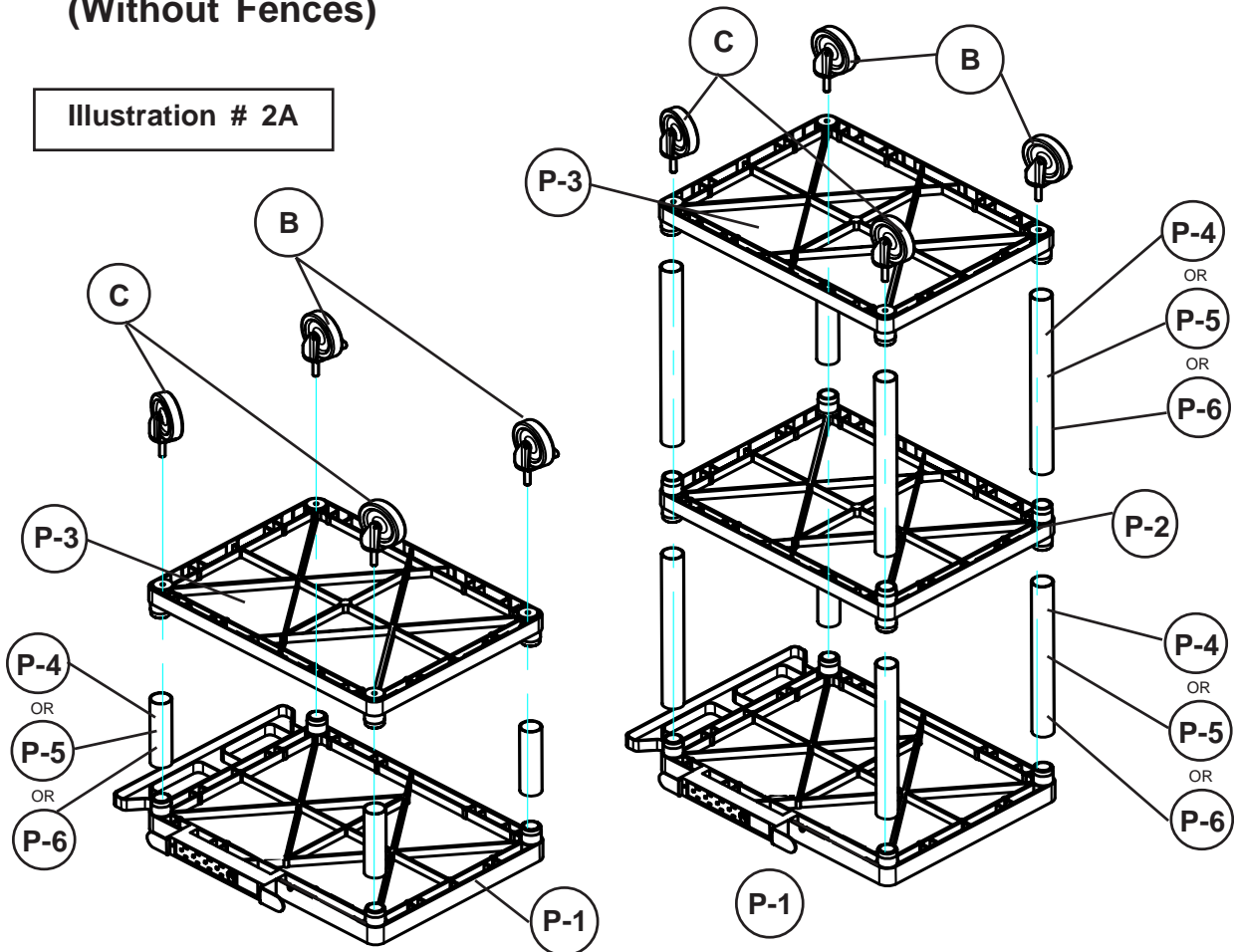

Your new **All Service Cart** can be assembled in multiple heights and shelf configurations.

Each cart contains three sets of different length support Tubes (P-4), (P-5) and (P-6). You can assemble your new cart in either a two Shelf (P-1) + (P-3) or three Shelf (P-1) + (P-2) + (P-3) layout.

**NOTE:** You must use four of the same length Tubes between each Shelf.

## ASSEMBLY INSTRUCTIONS for a Two Shelf Cart

- 1.) Lay Top Shelf (P-1) with Electrical Outlet Strip attached face down on floor.
- 2.) Choose four like support Tubes (P-4) or (P-5) or (P-6) depending on the height unit you need and insert them into the corners of Top Shelf (P-1).
- 3.) Place Bottom Shelf (P-3) into support Tubes as shown in Illustration #2A.
- 4.) Push in two Locking Casters (B) and two Casters (C) into the caster mount holes in the bottom corners of Bottom Shelf (P-3).

## ASSEMBLY INSTRUCTIONS for a Three Shelf Cart

- 1.) Follow steps 1 and 2 as described above.
- 2.) Place Middle Shelf (P-2) into support Tubes as shown in Illustration #2B.
- 3.) Choose four like support Tubes out of your remaining Tubes and insert them into the corners of Middle Shelf (P-2).
- 4.) Place Bottom Shelf (P-3) into support Tubes as shown in Illustration #2B.
- 5.) Push in two Locking Casters (B) and two Casters (C) into the caster mount holes in the corners of Bottom Shelf (P-3)

**Missing Parts or UPS Damaged Parts**

For Your Convenience you can

EMAIL us at

**[furniture@baltinc.com](mailto:furniture@baltinc.com)**

24HOURS 7 DAYS A WEEK

*Should you require assistance during assembly,*

*please call our Customer Service Department*

*Monday - Friday 8 a.m. - 5 p.m.*

*Central Standard Time*

*1-800-749-2258*

## All Service Cart Fence Assembly

F1.) Slide 2 Large Fences (P-9) into the slots on 2 longer sides of the Middle Shelf (P-2), or the Bottom Shelf (P-3) as shown in illustration # 3.

F2.) Slide 2 Small Fences (P-8) into the slots on 2 shorter sides of the Middle Shelf (P-2), or the Bottom Shelf (P-3).

F3.) Slide 4 Collars (P-7) over the 4 Tubes, and press over the top of the 4 fences as shown in illustration # 4. Secure fences using 16 Screws (A).

