

ASSEMBLY INSTRUCTIONS

Corner Floor Cabinet

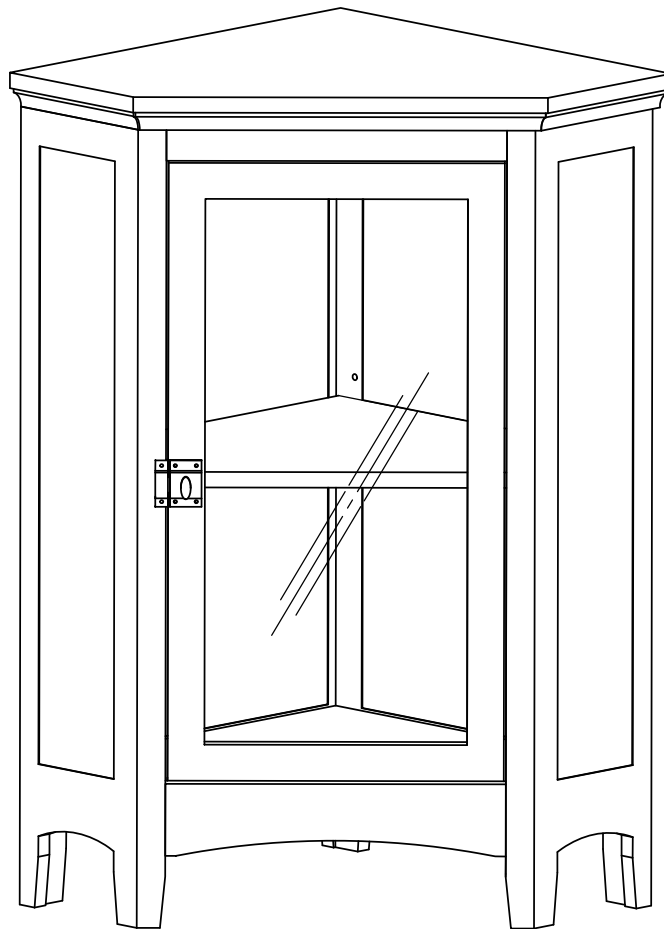

ASSEMBLY INSTRUCTIONS-IMPORTANT

Carefully unpack & identify each component before attempting to assemble. Refer to parts list. Please take care when assembling the unit and always set the parts on a clean, soft surface. If you require any assistance with assembly, parts, please contact us at replacement@elegantfh.net. Please have the following information ready when contacting for parts or questions: the name of the company you purchased from, the purchase order number, and the original order date.

INSTRUCCIONES PARA ARMAR-IMPORANT:

Desempaque cuidadosamente e identifique cada componente antes de tartar de empezar su ensambladura. Verifique la lista de partes. Por favor tenga cuidado cuando arme la unidad y siempre coloque las piezas sobre una superficie plana, suave y limpia. Si necesita ayuda con el armado, por favor contacte con nosotros en replacement@elegantfh.net.

DIRECTIVES DE MONTAGE-IMPORTANT:

Avant de commencer l'assemblage, déballez délicatement toutes les pièces et repérez-les sur la liste des pièces. Procédez avec soins durant l'assemblage et posez toujours les pièces sur une surface proper, douce et lisse. Si vous avez besoin d'aide cocernant l'assemblage Se il vous plaît contactez -nous au replacement@elegantfh.net.

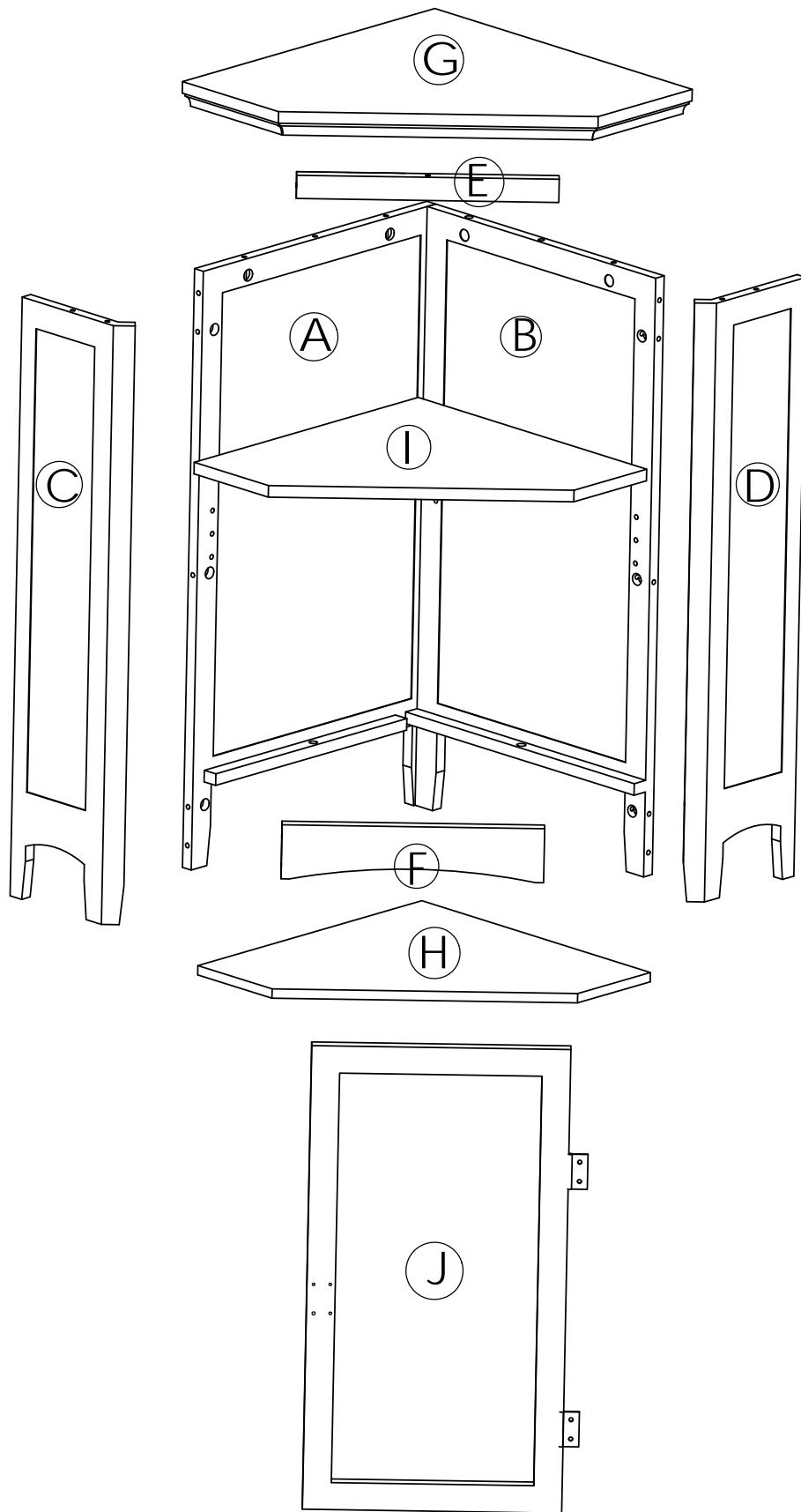

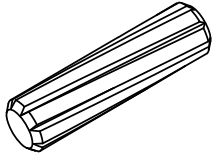
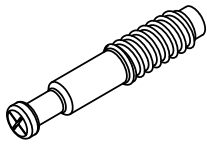
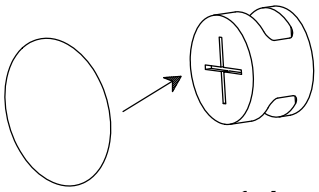
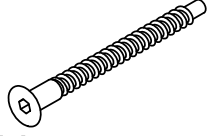
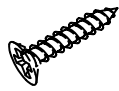
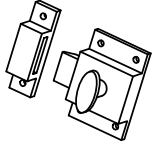
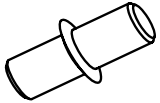
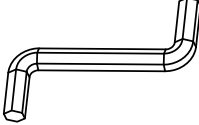
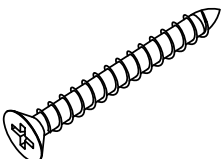
<p>1</p>  <p>ϕ6x30mm 10pcs</p>	<p>2</p>  <p>16pcs</p>	<p>3</p>  <p>16pcs</p>
<p>4</p>  <p>M5X40mm 3pcs</p>	<p>5</p>  <p>M3X12mm 14pcs</p>	<p>6</p>  <p>1pc</p>
<p>7</p>  <p>5pcs</p>	<p>8</p>  <p>1pcs</p>	<p>9</p>  <p>M3X25mm 4pcs</p>

STEP 1

ÉTAPE 1

PASO 1

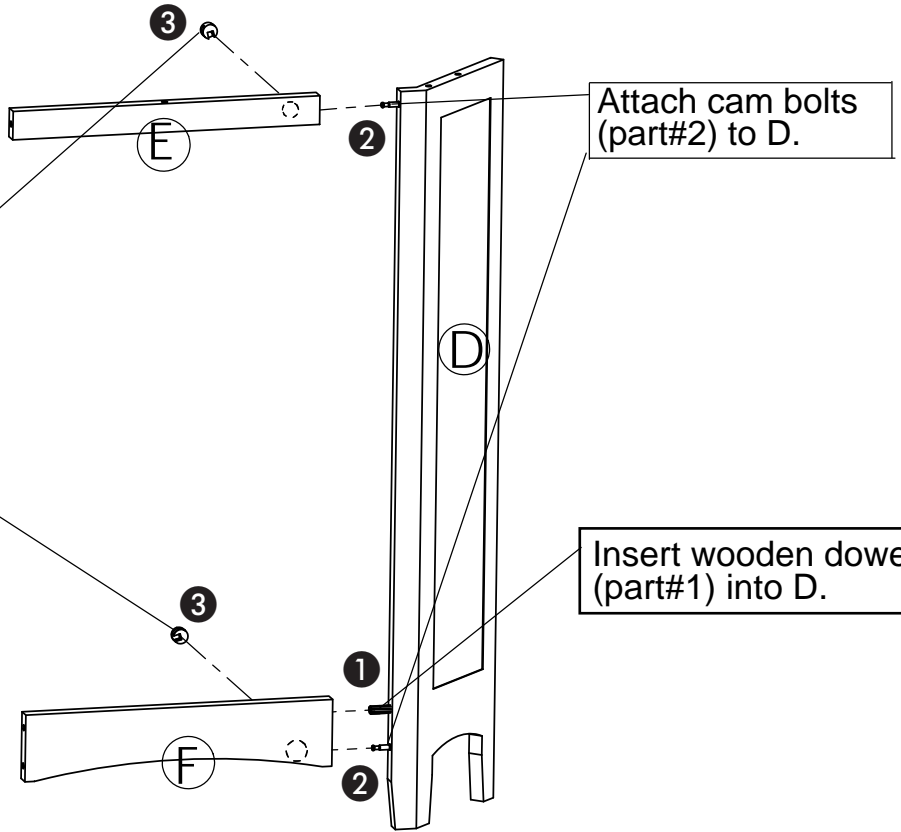

****Kindly remind****
If you're having trouble with the camlocks locking on to the cambolt, loosen the cambolt by 1/4 of a turn, and the problem should be resolved.

STEP 2

ÉTAPE 2

PASO 2

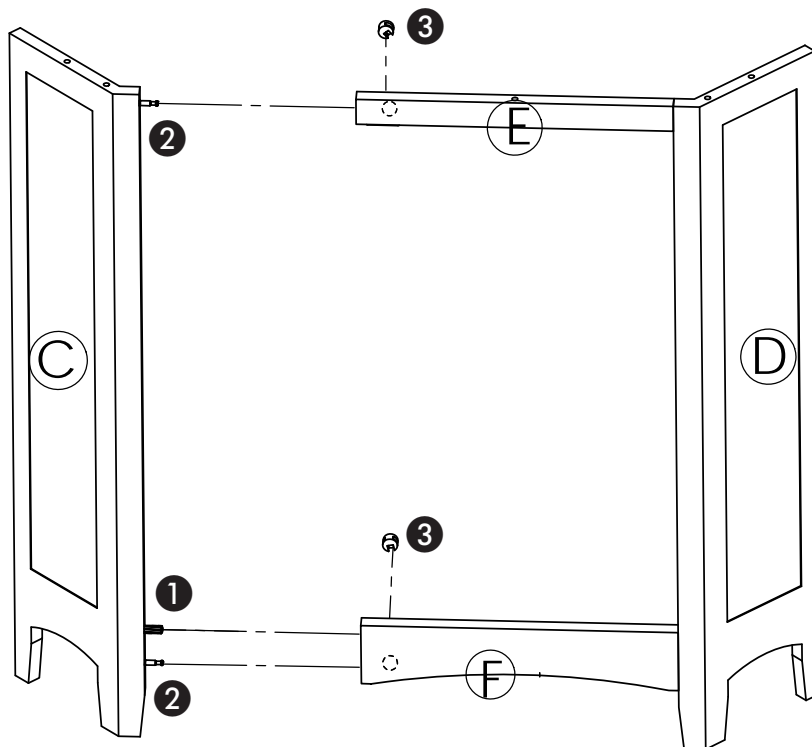

STEP 3

ÉTAPE 3

PASO 3

Insert wooden dowels(part#1) into panel D.

Insert cam locks (part#3) into panel B. And turn cam locks clockwise to secure B to D.

Attach cam bolts (part#2) to D.

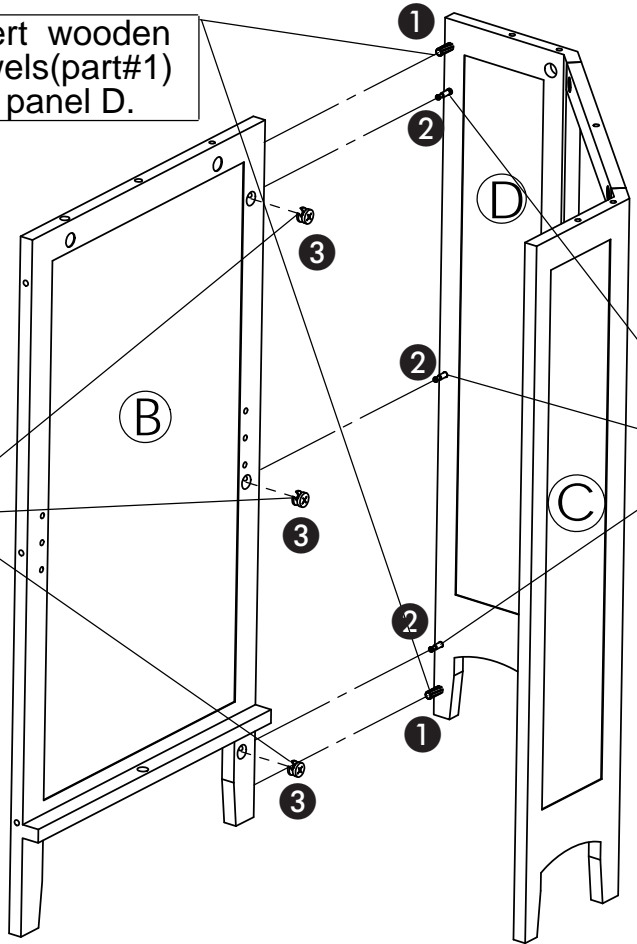

STEP 4

ÉTAPE 4

PASO 4

Insert cam locks (part#3) into panel A. And turn cam locks clockwise to secure A to C.

Attach cam bolts (part#2) to C.

Insert wooden dowels(part#1) into panel C.

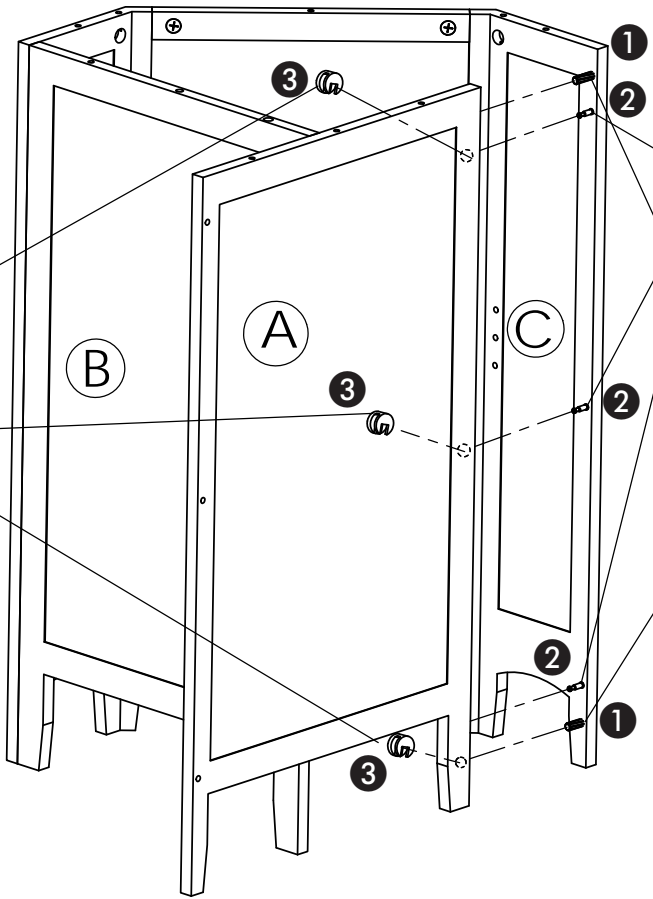

STEP 5

ÉTAPE 5

PASO 5

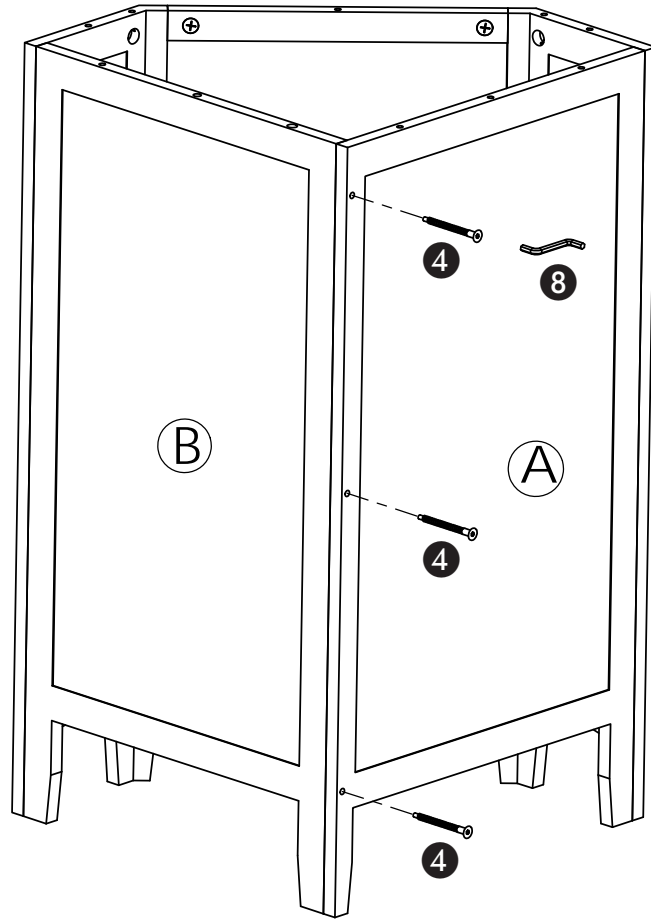

STEP 6

ÉTAPE 6

PASO 6

Attach cam bolts(part#2) to board G

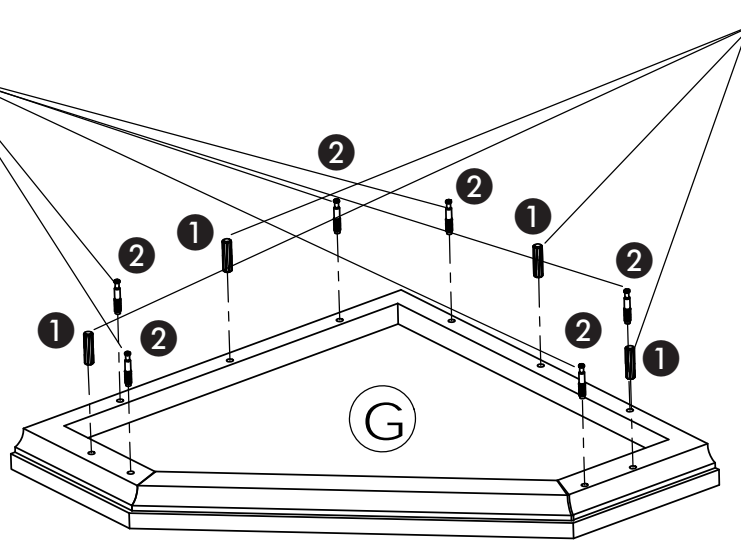

Insert wooden dowels(part#1)into board G

STEP 7
ÉTAPE 7
PASO 7

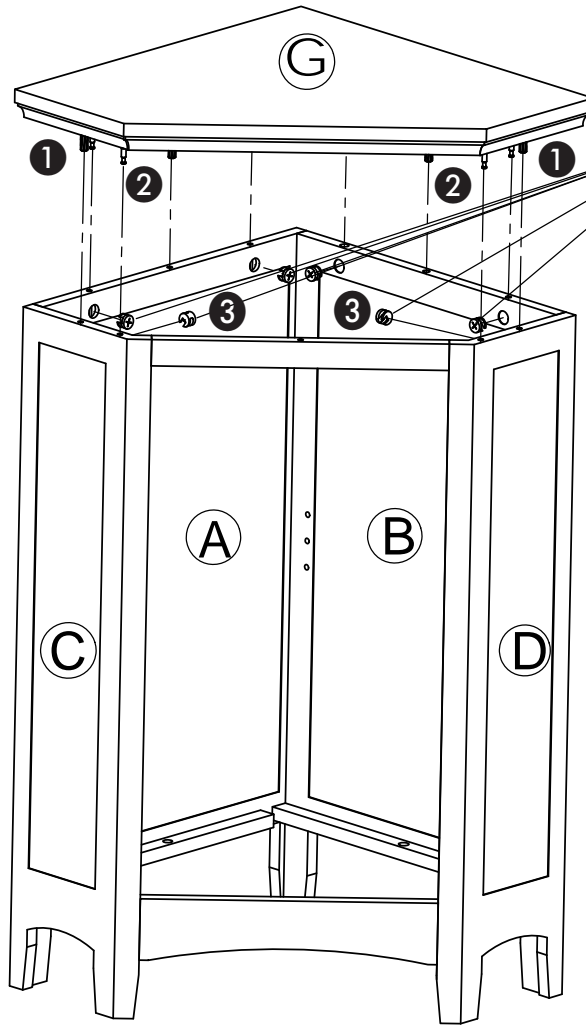

Insert cam locks (part#3) into A,B,C & D, and turn cam locks clockwise to secure A,B,C&D to G.

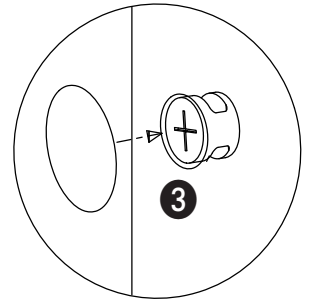

STEP 8
ÉTAPE 8
PASO 8

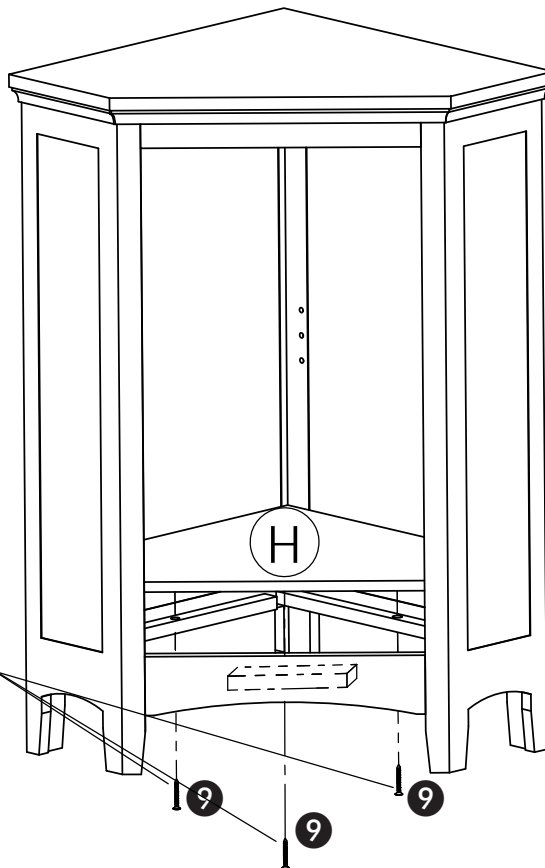

Secure Panel H with screws(part#9).

STEP 9

ÉTAPE 9

PASO 9

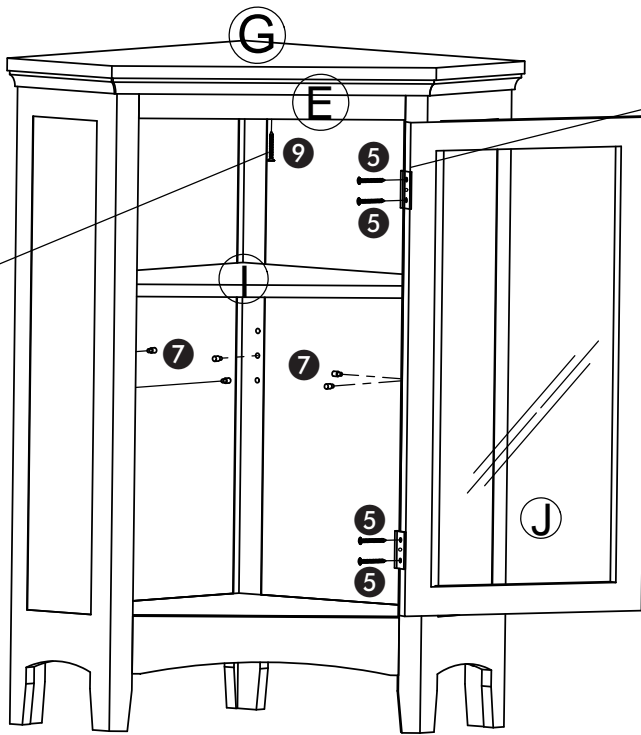

Secure E & G with screw(part#9).

Door Aligning Instructions

Attach the hinges with screws(part#5).Adjust the position of the hinges so the door lines up with the opening prior to tightening the screws.

Finish by securing the hinges to the cabinet.

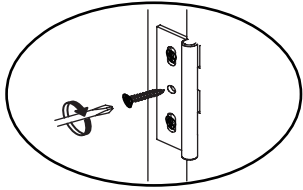

Loosen the screws attaching the hinges to the door itself and adjust their positioning if required,then tighten the screws again.

Finish by securing the hinges to the door.

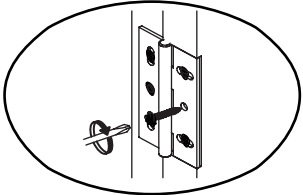

STEP 10

ÉTAPE 10

PASO 10

