



Technical Data

LiquidMate® LIQUID SOAP DISPENSER

B-155



Patented

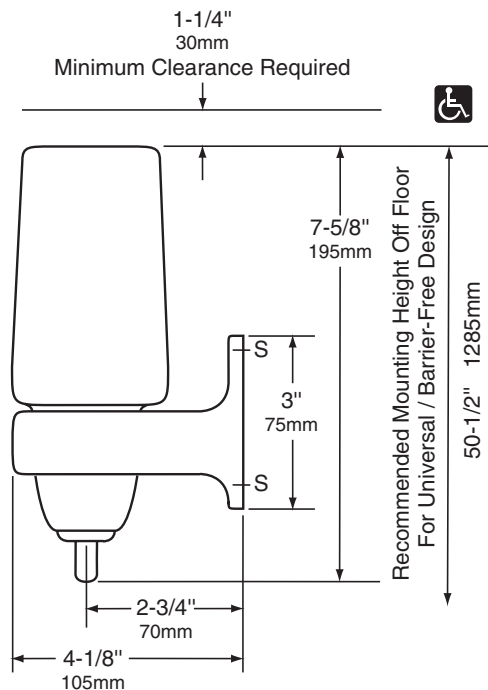
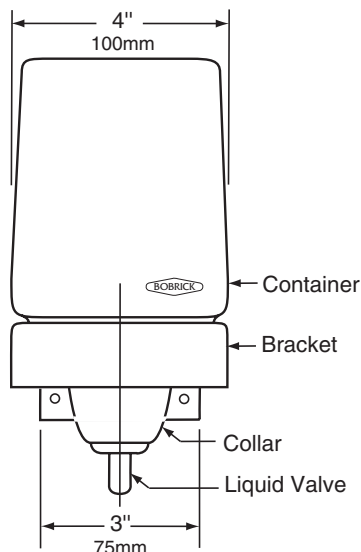

MATERIALS:

Bracket and Collar — Bright polished chrome-plated ABS.

Container — Translucent, shatter-resistant polyethylene. Capacity: 24 fl oz (0.7 L).

Valve — Grey ABS with stainless steel spring. Corrosion-resistant.

OPERATION:

Push valve up to dispense measured amount of thin, free-flowing commercially marketed all-purpose hand soaps. Valve operates with one hand, without tight grasping, pinching, or twisting of the wrist, and with less than 5 pounds of force (22.2 N) to comply with barrier-free accessibility guidelines (including ADAAG in U.S.A.). Only after the collar is unscrewed at base of unit can the valve be removed from the container for filling. Translucent container provides visible soap level.

INSTALLATION:

Secure dispenser to the wall with four sheet-metal screws, furnished by manufacturer, at points indicated by an S. Unit can also be secured to mirror or glass surface with adhesive mounting kit, available as an optional accessory: order Bobrick Part No. 190-40. For plaster or dry wall construction, provide concealed backing to comply with local building codes, then secure with sheet-metal screws furnished. For other wall surfaces, provide fiber plugs or expansion shields for use with sheet-metal screws furnished, or provide 1/8" (3mm) toggle bolts or expansion bolts.

Note: Provide 1-1/4" (32mm) minimum clearance from cap to underside of any horizontal projection. Valve should be located 44" (1120mm) maximum above the finish floor.

SPECIFICATION:

Soap dispenser shall have bright polished chrome-plated ABS bracket and collar. Corrosion-resistant valve shall dispense thin, free-flowing commercially marketed all-purpose hand soaps. Valve shall be operable with one hand and with less than 5 pounds of force (22.2 N) to comply with barrier-free accessibility guidelines (including ADAAG in U.S.A.). Container shall be translucent, shatter-resistant polyethylene with a capacity of 24 fl oz (0.7 L). Manufacturer's service and parts manual shall be provided to the building owner/manager upon completion of project.

Liquid Soap Dispenser shall be Model B-155 of Bobrick Washroom Equipment, Inc., Clifton Park, New York; Jackson, Tennessee; Los Angeles, California; Bobrick Washroom Equipment Company, Scarborough, Ontario; Bobrick Washroom Equipment Pty. Ltd., Australia; and Bobrick Washroom Equipment Limited, United Kingdom.