

Component Checklist

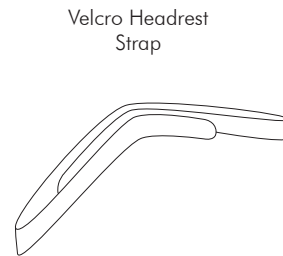
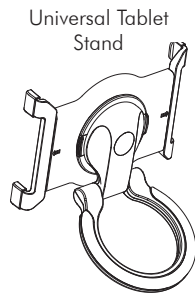

IMPORTANT INFORMATION:

! IMPORTANT - Install Visidec VTB-US Universal Tablet Stand as per installation instruction.
 ! The manufacturer accepts no responsibility for incorrect installation.

Step 1. Check Components

Check you have received all components against the component checklist above.

Step 2. Tablet installation & mounting options

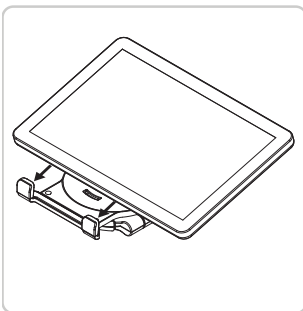

Place tablet on one side of mount

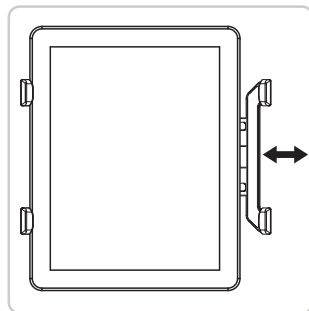

Pull open the mount over the tablet and release

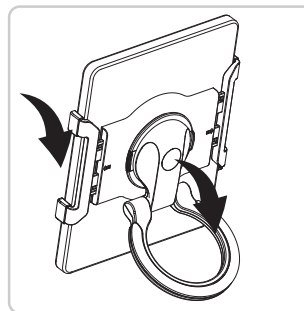

Vertical view with angle adjustment



Horizontal view with angle adjustment

Caution: Ensure the tablet is securely fixed in position.

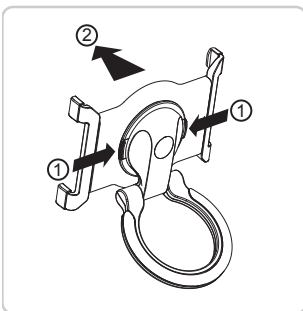

Quick release removable stand

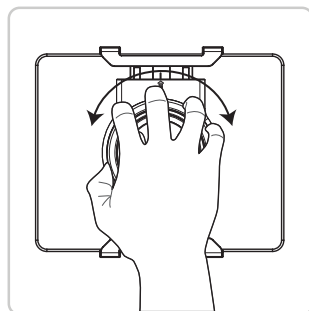

Handheld Rotation

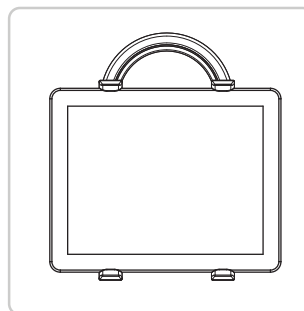

Hanging & Portable

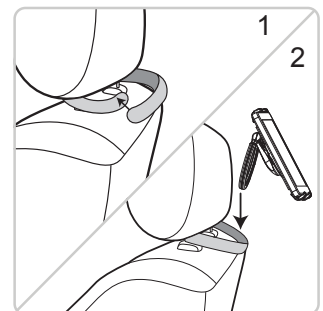

Use Velcro Headrest strap to attach to rear of car seat

Installation Complete

