

HOBART®

HOBART BROTHERS CO.
TROY, OHIO USA

5/3/1
INDUSTRIAL
WARRANTY

IronMan™ 230



243749
March 2012

Complete Single-Phase MIG Welding Package



230 Volt

Spool Gun Ready!

#500536

Includes:

- 15 ft., 200-amp MIG welding gun
- Regulator/flow gauge
- 5 ft. gas hose
- 10 ft. primary input cable with plug
- Dual-groove drive roll — .030/.035 in.
- 10 ft. work cable with clamp
- Dual side-mounted cable hangers
- Extra contact tips
- Built-in running gear/cylinder rack
- Weld, set-up and parts information chart

The IronMan 230 is a total redesign of the full-size MIG platform, outperforming the competition on arc quality, voltage control, and value. It delivers 30 to 250 amps of pure power in a heavy duty cabinet. The arc of the new IronMan is optimized to deliver a flawless weld, making spatter and post-weld cleanup almost nonexistent. Whether you're a professional or just want to weld like one, the IronMan 230 is unmatched in its class. It is equipped with many outstanding features.

- Welds 24 gauge up to 1/2 in. (13 mm) thick steel.
- Excellent aluminum welding with optional Hobart Direct Connect Spool Gun DP 3545-20.
- Twelve-tap voltage control allows for a smooth, easy-to-control arc.
- Infinite wire feed speed control for precise adjustment of penetration and weld bead shape.
- Spool hub that makes changing from 2, 10, 33 and 45 lb. wire spools a snap with a tool-less brake tension knob and automatic wire alignment.
- Built-in self-resetting thermal overload system protects the unit in the toughest applications.
- Reversible drive rolls: two grooves for two wire sizes on one drive roll. Decreases spare parts and changeover time.
- Dual-gear wire drive system with aluminum housing delivers 0 to 700 IPM wire feed speed.
- Hinged door for easy access to wire drive system for spool and drive roll changes.
- Convenient storage area is located inside the cabinet for spare tips, nozzles and drive rolls.

Features	Benefits
Sloped front panel	Makes controls easy to see and access.
Arc performance	Excellent short arc performance with easy to control weld puddle.
175 amps @ 60% duty cycle, and wide amperage range	High machine-output duty cycle, increasing productivity with longer welding periods. Versatile for MIG and Flux-cored, gas or gasless welding applications. Can weld at higher amps at lower duty cycle.
12-position voltage control	Simplified and accurate adjustments. Maximizes amount of control. Allows for smooth arc with high operator appeal.
Spool gun ready	Easy setup for welding aluminum with no additional interface
Reversible drive rolls: two grooves for two wire sizes on one drive roll	50% less stocking of drive rolls. Standard, one-piece drive roll decreases spare parts and changeover time, reducing overall costs.
Hinged feeder panel	For greater accessibility to wire feeder panel for spool and feed roll changes, increasing productivity and operator appeal.
Infinite wire feed control	Allows for precise adjustment of penetration and weld bead shape.
Dual side-mounted cable hangers	Convenient storage for cables when not in use.
Fan-On-Demand	Cooling system operates only when needed reducing power consumption and contaminants drawn into the machine.
Comes complete with factory installed features	Ready to set up and weld: comes complete with wire feeder, running gear, cylinder rack, regulator/flow gauge, MIG gun, cable and clamp, extra tips.
Hobart's 5/3/1 Industrial Warranty	Five-year warranty on transformers, stabilizers and generators; three years on electronics (drive motors, rectifiers); and one year on guns (MIG and plasma torches).

Specifications (SUBJECT TO CHANGE WITHOUT NOTICE.)



Rated Output	Current Range	Open Circuit Voltage	Wire Feed Speed Range	Amperes Input at Rated Load				Dimensions	Net Weight
				200 V	230 V	KVA	KW		
175 A, 25.5 V DC at 60% duty cycle 250 A, 23 V DC at 30% duty cycle	30–250 amps	38 V	0–700 IPM	37	32.5	7.4	6.3	H: 31-1/2 in. (800 mm) W: 18-7/8 in. (479 mm) D: 36-1/2 in. (927 mm)	185 lb. (84 kg)

Certified by Canadian Standards Association to both Canadian and U.S. Standards.
 Note: Operating Temperature Range: -4° to +104°F (-20° to +40°C)

Control Panel

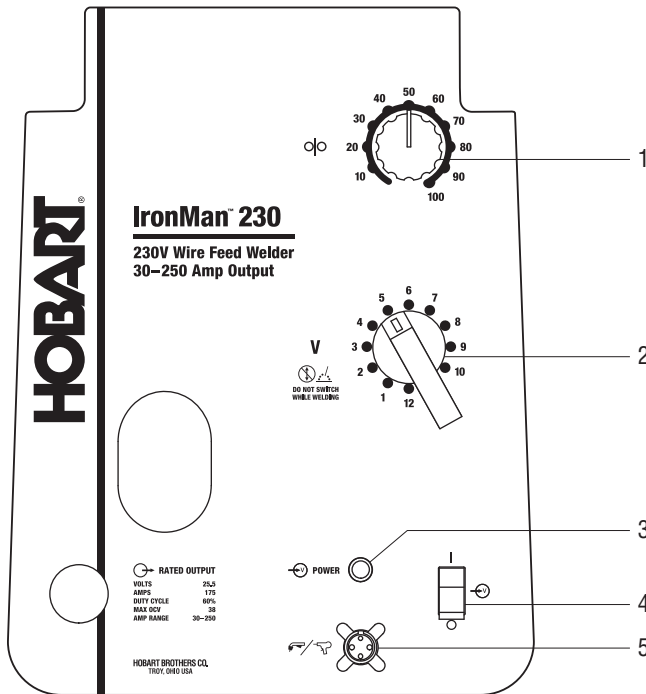

Performance Data

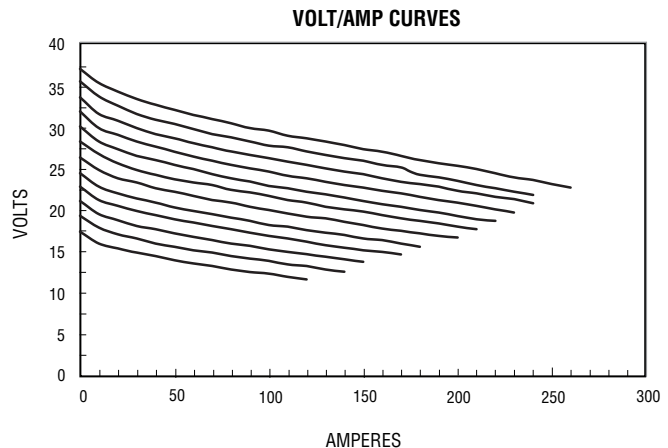
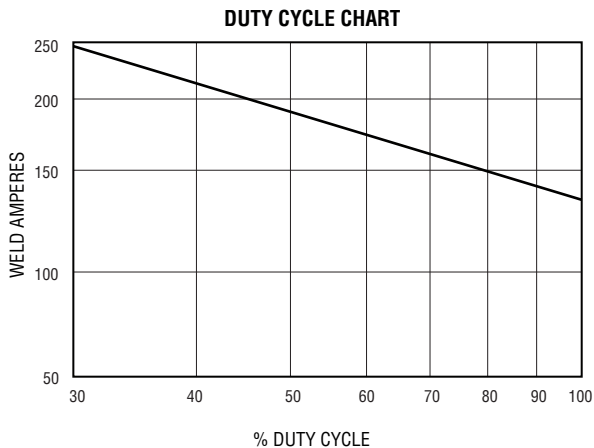

Accessories



Protective Cover #770589

Form-fitted, vinyl-laminated, polyester fabric resists stains and mildew and protects the finish of your welder.



Reversible V-Groove Drive Rolls for Mild Steel Wire

#235286

.030/.035 in. (0.8/0.9 mm)

#235287

.023 and .045 in. (0.6–1.1 mm)

Reversible V-Knurled Drive Rolls for Flux-Cored Wire

#132958

.035 in. (0.9 mm)

#132957

.045 in. (1.2 mm)

MIG GUN AND ACCESSORIES

H200L4-15 Replacement Gun

#239173 15 ft. (4.6 m)

Gun designed to run .030–.035 in. (0.8–0.9 mm) wire.

Gun rated at 200 amps, 100% duty cycle using CO₂ gas, and 60% duty cycle using mixed gas.

Contact Tips (See chart on below)

Nozzle (See chart below)

Adapter (See chart below)



Replacement Liners (See chart below)



Contact Tips (5 per package)

#199387 For .030 in. (0.8 mm) wire.

#199388 For .035 in. (0.9 mm) wire.

#199389 For .047 in. (1.2 mm) wire.



Nozzle #199386



Drive Roll (1)

#186413 For .030/.035 in. (0.8/0.9 mm) wire.

#199396 For .047 in. (1.2 mm) wire.

SPOOL GUN AND ACCESSORIES



Hobart Spool Gun DP 3545-20 #300349

Spool gun with 4 in. spool, rated at 200 A, 60% duty cycle. Includes 20 ft. cable assembly. When combined with IronMan 230, this spool gun welds with .030–.047 in. wire on 18 ga. – 1/2 in. thick aluminum.



Push Roll (1)

#186414 For .030/.035 in. (0.8/0.9 mm) wire.

#199397 For .047 in. (1.2 mm) wire.

Consumables

Item	Hobart Package Part #
Contact Tips	
.023/.025 in. (0.6 mm)	#770174 (5 per package)
.030 in. (0.8 mm)	#770177 (5 per package)
.035 in. (0.9 mm)	#770180 (5 per package)
.045 in. (1.2 mm)	#770183 (5 per package)
Flush Nozzle 5/8 in. (16 mm) orifice	#770405
Tip Adapter	#770403
Replacement Liners	
.023/.025 in. (0.6 mm)	#196139
.030/.035 in. (0.8/0.9 mm)	#196139
.035/.045 in. (0.9/1.2 mm)	#196140



Hobart Welders An Illinois Tool Works Company

Hobart Welding Products Service 800-332-3281 Sales 800-626-9420

Litho in USA

hobartwelders.com

