

ASSEMBLY INSTRUCTIONS: MOBILE MULTI-USER WORKSTATION (1600)

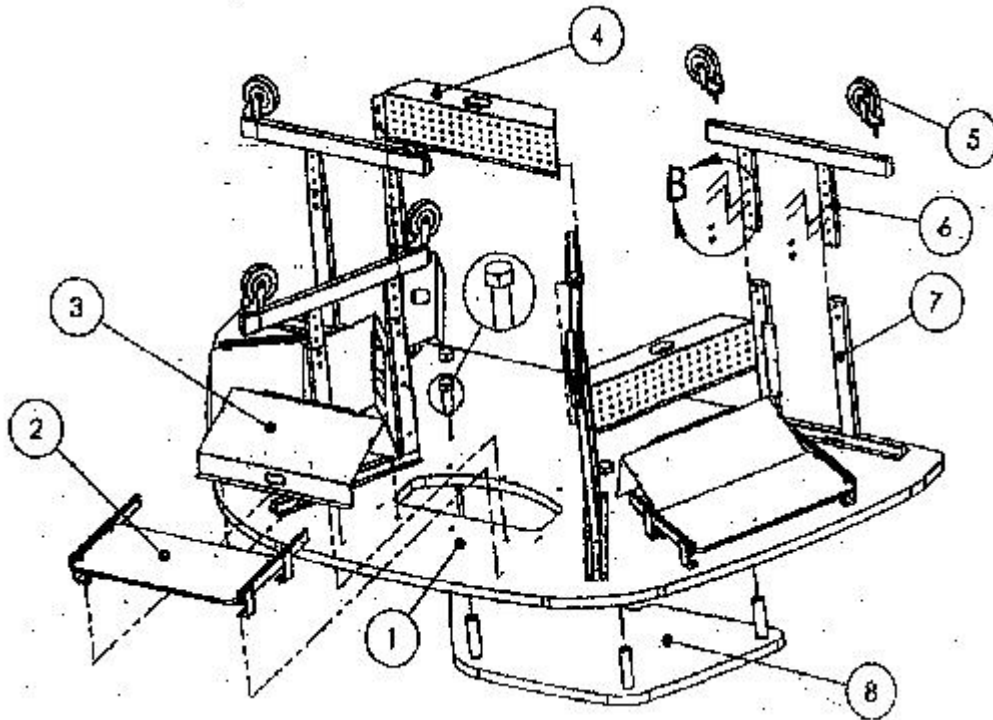

| HARDWARE | | |
|----------|-------------|-------------------------------|
| QUANTITY | PART NUMBER | DESCRIPTION |
| 8 | 1010550 | 1/4-20 LOCKNUT |
| 36 | 1010555 | 10/32-1/2" MACHINE SCREW |
| 12 | 1010565 | 1/4-20 X 1 1/2" MACHINE SCREW |
| 4 | 1010566 | 1/4-20 X 1 3/4" MACHINE SCREW |
| 16 | 1010570 | 1/4-20 X 1/2" HEX HEAD BOLT |

OTHER REQUIRED TOOLS: PHILLIPS SCREWDRIVER, CORDLESS DRILL WITH TORQUE CONTROL, AND 7/16 WRENCH

INSTRUCTIONS

1. Lay top down on a clean scratch free surface.
2. If you ordered the optional keyboard trays, install them first.
3. Fully extend the keyboard trays and place the monitor tub over the corresponding hole patterns. Tighten the monitor tub to the top using six 10/32 x 1/2" machine screws.
4. Insert casters into each leg lower. Tighten with the caster wrench provided.
5. Install four 1/4-20 x 1/2" hex head bolts into the leg lower and align with the leg upper. Set to the desired height and tighten with your 7/16 wrench.
6. Place the assembled legs over the appropriate holes and tighten using six 10-32 x 1/2" machine screws per leg.



1-800-451-8546

www.paragoninc.com

7. Attach the wire chases to the uprights on the legs using four $\frac{1}{4}$ -20 x $1\frac{3}{4}$ " machine screws in the indicated holes and secure them with $\frac{1}{4}$ -20 locknuts using your $7/16$ wrench. The center chase will share the same screws and nuts as the outside chases.
8. Use two people to turn the fully assembled table over.
9. If you ordered a riser, place the riser over the appropriate holes and secure using the $\frac{1}{4}$ -20 x $1\frac{3}{4}$ " machine screws from underneath the top.