

## ASSEMBLY INSTRUCTIONS: MOBILE COMPUTER RACK (CPU-M)

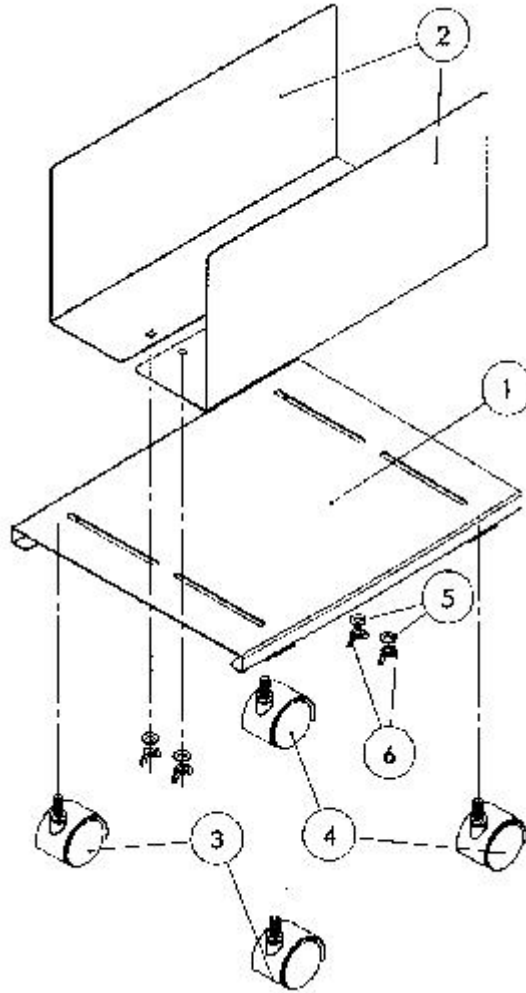

HARDWARE		
QUANTITY	PART NUMBER	DESCRIPTION
4	10105742	1/4-20 WING NUT
4	10105743	1/4-1" FENDER WASHER

### INSTRUCTIONS

1. Insert two locking casters into the base by screwing the threaded end of the caster into the threaded insert located on the bottom of the base. Securely tighten the locking caster using a small crescent wrench.
2. Repeat step 1 using the non-locking casters in the remaining two threaded inserts.
3. Take one side and insert the two 1/4-20 studs protruding from the bottom into the oblong holes in the base. From the opposite side attach one 1/4-1" fender washer and one 1/4-20 wing nut loosely onto each 1/4-20 stud.



1-800-451-8546

[www.paragoninc.com](http://www.paragoninc.com)

4. Repeat step 3 with the other side. When you have finished, the two sides should be facing each other.
  5. Place either one or two CPU in between each side. Push the sides together firmly so that they are captured between the sides. Snugly tighten the wing nuts underneath.
- CAUTION: Remember to unplug all wires and cables from the back of your CPU before moving your unit.