

ASSEMBLY INSTRUCTIONS: FLIP DOOR DESK (FD)

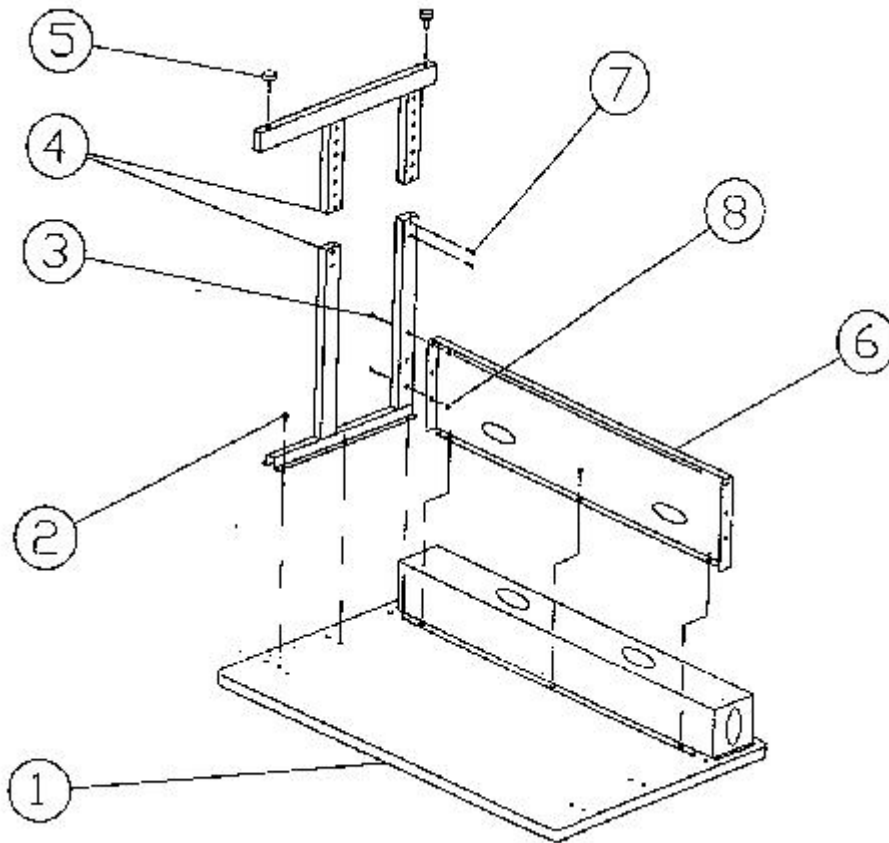

HARDWARE		
QUANTITY	PART NUMBER	DESCRIPTION
4	1010530	FLOOR GLIDE
2	1010535	RUBBER GROMMET
4	1010550	¼-20 LOCKNUT
17	1010555	10/32 X ½" MACHINE SCREW
4	1010565	¼-20 X 1 ½" MACHINE SCREW
8	1010570	¼-20 X ½" HEX HEAD BOLT

INSTRUCTIONS

1. Lay top upside down on a clean, scratch free surface.
2. Fasten right leg to top as shown using six 10-32 x ½" machine screws. Finger tighten only.
3. Adjust right leg to desired height and fasten bottom to top using four ¼-20 x ½" hex head bolts. Tighten these bolts.
4. Fasten two floor glides to bottom of the right leg.
5. Repeat steps two through four for left leg at the opposite end of the top.
6. Align the modesty panel over the three mounting holes in top and fasten using three 10/32 x ½" machine screws. Finger tighten only.



1-800-451-8546

www.paragoninc.com

7. Align holes in the right leg and modesty panel and fasten together using two ¼-20 x 1 ½” machine screws and two ¼-20 locknuts. Do not completely tighten at this time.
8. Repeat step seven at opposite end of the top with left leg.
9. At this time, go back and tighten all fasteners.
10. If you have purchased optional keyboard trays, assemble the keyboard tray per the separate instructions and hardware provided using mounting option “A” designated in those instructions.
11. If you have purchased optional SR814, assemble per the separate hardware and instructions provided.
12. Using two or more people, place assembled table upright.
13. If you have purchased optional CPU platforms, assemble per the separate hardware and instructions provided.