

Made in China

PARTS

HARDWARE ILLUSTRATION

Tools required: Screwdriver (not included)

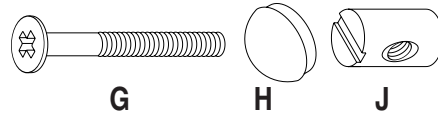

- (A) POSTS (2)
- (B) LEGS (4)
- (C) LARGE END CAPS (4)
- (D) ARMS (4)
- (E) SQUARE CROSS BRACES (2)
- (F) ROUND CROSS BRACES (2)
- (G) MACHINE SCREWS (4)
- (H) WOOD PLUGS (4)
- (I) SMALL END CAPS (4)
- (J) HANGER BOLTS (4)

Thank you for purchasing this quality product. Be sure to check all packing material carefully for small parts which may have come loose inside the carton during shipment. Separate, identify, and count all parts and metal hardware. Compare with parts list to be sure all parts are present. If any part(s) are missing or damaged, phone, fax, or mail to our Customer Service Department. For efficient and speedy service, please indicate the model number and code letter of part(s) needed.

ATTENTION: SOME NUMBERED PARTS LISTED ON THE INSTRUCTION SHEET MAY NOT BE IN PARTS BAG AS THEY MAY ALREADY BE ASSEMBLED. CAREFULLY CHECK PARTS AND PACKING MATERIALS PRIOR TO ORDERING REPLACEMENTS.

IMPORTANT NOTE: Follow instructions listed below in the proper sequence as numbered to assure fast, easy and correct assembly.

1. **Note:** Upon opening, thoroughly clean all wood surfaces with furniture polish to remove dust and dirt that may have settled onto finish during shipment.
2. Slide Legs (B) into grooves on one end of Posts (A). Tighten Large End Caps (C) into bottom edge of Legs (B) to secure Legs (B) to Posts (A).
3. Slide Arms (D) into grooves on opposite end of Posts (A). Tighten Large End Caps (C) into top edge of Arms (D) to secure Arms (D) in place. Be sure that large holes on Arms (D) are facing inward toward each other.
4. Align Square Cross Braces (E) with slots in Posts (A). Insert Hanger Bolts (J) into large holes near ends of Square Cross Braces (E) with threads pointing outward. If necessary, rotate Hanger Bolts (J) so that threads will align with Machine Screws (G). Insert Machine Screws (G) through Posts (A), Legs (B), and tighten into Hanger Bolts (J).
5. Align Round Cross Braces (F) with large holes on ends of Arms (D). Insert threads of Small End Caps (I) through small hole in Arms (D) and tighten into ends of Round Cross Braces (F). Be sure that large holes on Arms (D) are facing toward each other.
6. Insert Wood Plugs (H) into screw holes on Posts (A).
7. Your furniture has been handcrafted and skillfully finished by fine craftsmen. Rich, deep antique finishes have been applied which require very little polish. However, should you desire a shinier finish, simply use any good grade of furniture polish, rubbing the finish lightly as it is being applied. Allow to dry and buff lightly with a soft cloth.

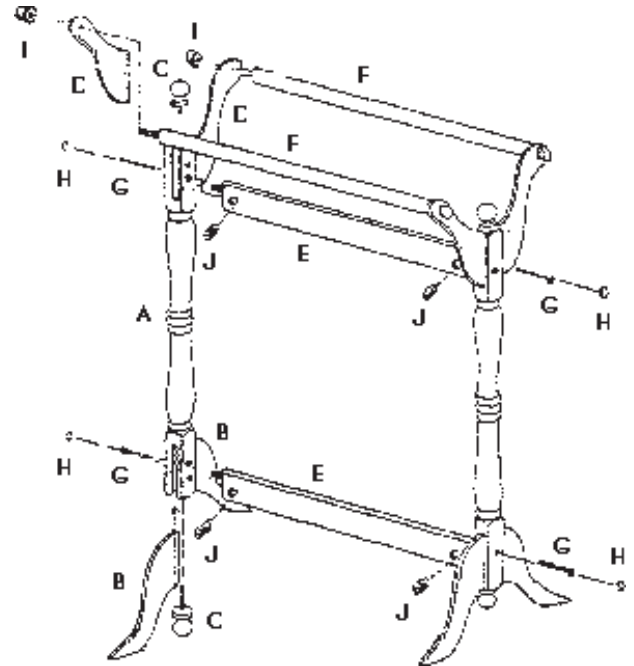

IF YOU HAVE A PROBLEM, WE WANT TO HAVE THE OPPORTUNITY TO MAKE IT RIGHT!

Should there be any missing or defective part(s),

FAX this form to (310) 841-0842

or call and ask for Customer Service at (800) 622-4456 or (310) 204-2224. Have your model number and part code letter handy.

MODEL NO. 441 "HEIRLOOM CHERRY"
442 "NOSTALGIC OAK"

© 1991Powell

Name _____

Address _____

Daytime Phone () _____

Reason for Replacement _____

Place of Purchase _____

Part Letter	Description	Quantity