

# EM20200-3

## SCREEN BACK TASK CHAIR

### OPERATING INSTRUCTIONS



#### **FEATURE**

##### • **HEIGHT ADJUSTMENT**

To raise seat remove pressure from seat and lift lever (1). To lower seat height sit on chair and lift lever (1).

**NOTE:** It is normal for chair to slightly lower under body weight.

#### **WARNING**

1. Use this product only one person at a time.
2. Do not use this chair unless all bolts screws and knobs are securely tightened.
3. Check that all bolts screws and knobs are tight every three months or as needed.
5. Dispose of packing material properly. Do not use plastic cover as head covering. It may cause suffocation.
6. Do not use chair as a stepladder.
7. Use this chair for its intended purpose only.
8. Use mild detergent only for cleaning.

#### **LIMITED WARRANTY**

Office Star chairs are warranted from the date of purchase against failure due to material and workmanship as follows:

- 5 Years on all non-moving metal parts.
- 2 Years on component parts including Control mechanisms, pneumatic cylinders, wood, plastic parts, base and casters.
- 1 Year on upholstery fabric and foam against wear and deterioration.

To make a warranty claim, contact Parts Department. Provide model number, proof of purchase, description of the problem and obtain return authorization. At it's option Office Star Products will:

- (a) Supply compatible components of current manufacture.
- (b) Repair the customer's component. The customer must prepay freight on any components returned to the factory. Return freight on components still in warranty will be paid by Office Star Products.

*\*All warranties are limited to the original purchaser for normal Residential usage by persons weighing 150 lbs. or less. This warranty will not cover labor, freight or damage from misuse, abuse, negligence, alteration, accident, vandalism, rusting, acts of nature or any other event beyond the control of Office Star Products. The warranty does not cover cosmetic damage that may result from normal use. Liability for incidental or consequential damages is excluded. The user assumes all risk of injury resulting from use of this product. This warranty gives you specific legal rights, and you may also have other rights which vary from state to state.*

Our quality standards are among the highest in the industry. Sometimes, no matter how hard we try, there are times when parts are damaged or missing. Our Parts Department will do everything possible to promptly remedy the problem. Contact us via e-mail [parts@officestar.net](mailto:parts@officestar.net), by Fax 1-909-930-5629, or toll free parts number 1-800-950-7262, Monday through Friday 8:00 a.m. - 5:00 p.m. Pacific Time.

# EM20200-3 SCREEN BACK TASK CHAIR ASSEMBLY INSTRUCTIONS

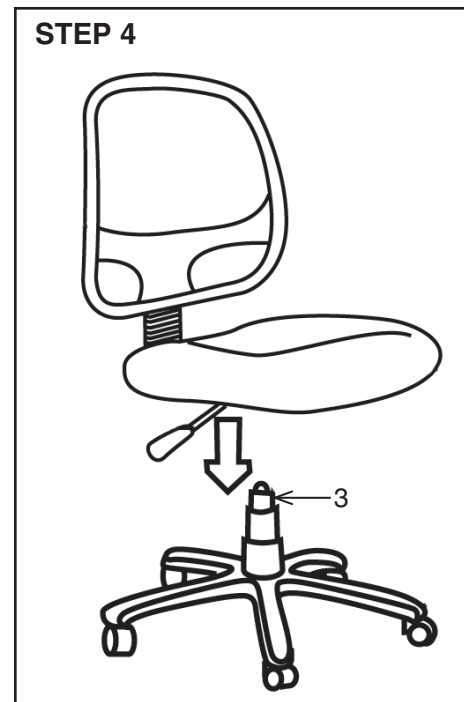
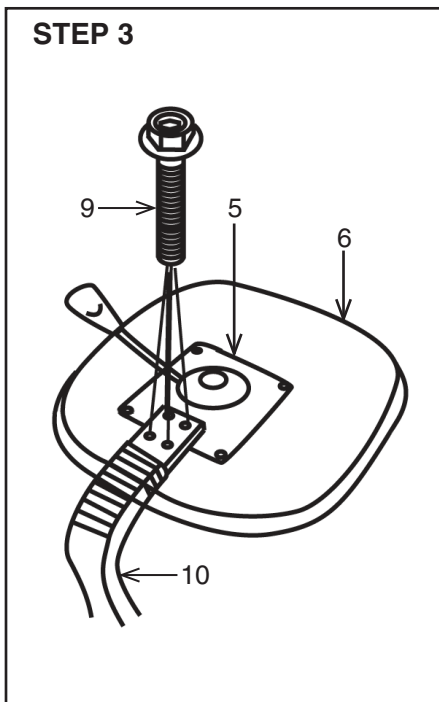
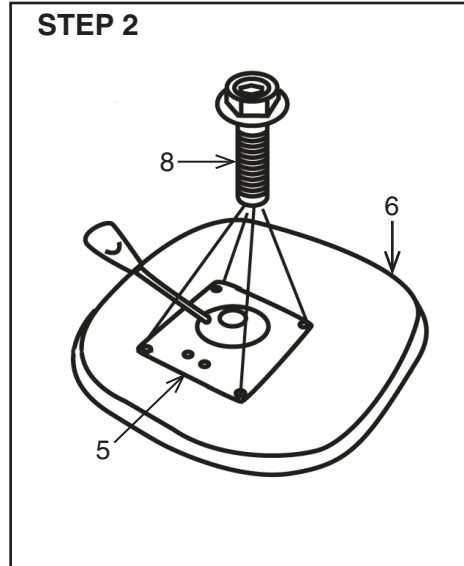
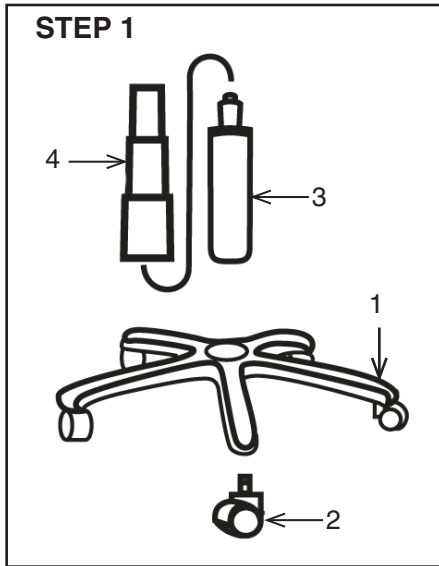

PART	QTY
1. Base	1
2. Casters	5
3. Pneumatic Cylinder	1
4. Bellows	1
5. Mechanism	1
6. Seat Cushion	1
7. Back Assembly	1
8. Short Screws	4
9. Long Screws	4
10. Back Support (pre-installed)	1
11. Allen Wrench (not shown)	1

Remove all parts from carton, separate by part numbers indicated on parts list, and verify part quantities.

**STEP 1** Insert five Casters (2) into Base (1), push hard until you feel or hear the Caster (2) snap into place. Insert Pneumatic Cylinder (3) into Base (1) and slip Bellows (4) over Pneumatic Cylinder (3).

**STEP 2** Attach Mechanism (5) to Seat Cushion (6) with the arrow towards the front of the chair, using four Short Screws (8).

**FULLY TIGHTEN ALL SCREWS USING ALLEN WRENCH (11).**

**STEP 3** Attach Back Support Assembly (7) to Seat Cushion (6) on top of Mechanism (5) and secure using four Long Screws (9).

**FULLY TIGHTEN ALL SCREWS USING ALLEN WRENCH (11).**

**STEP 4** Place the assembled seat on top of Pneumatic Cylinder (3) and apply downward pressure.

**ATTENTION: MAKE SURE ALL SCREWS ARE FULLY TIGHTENED BEFORE USING CHAIR.**

(This is a non printing page)

## Office Star Products: Instructions Printing Rules

The following must be followed:

1. No changes should be made to these documents. If changes are needed they must be made through Office Star Products.
2. All items will be printed at the size intended by Office Star Products. Finish trim size is 8 1/2" X 11"
3. All Items will be printed on a printing press unless other arrangements are made before printing.
4. Paper should be white, at least 80# gloss text and coated both sides.
5. Failure to follow these rules could result in back charges from Office Star Products.

