

# 8000/8001

## EXECUTIVE LEATHER CHAIR

### OPERATING INSTRUCTIONS

8000



8001



### FEATURES

#### • SEAT HEIGHT ADJUSTMENT

To raise seat remove pressure from seat and lift lever (1).  
To lower seat height sit on chair and lift lever (1).

**NOTE:** It is normal for chair to slightly lower under body weight.

#### • LOCKING TILT ADJUSTMENT

For individual comfort, this chair has been equipped with an adjustment that will allow the user to change the tension of the tilting feature. Turn knob (2) clockwise to increase tension and counter-clockwise to decrease or ease the tension. To lock return chair to the upright position and push lever (1) in.

To unlock pull lever (1) out.

**NOTE:** Be careful not to loosen back tilt adjustment knob completely.

### WARNING

1. Use this product only one person at a time.
2. Do not use this chair unless all bolts screws and knobs are securely tightened.
3. Check that all bolts screws and knobs are tight every three months or as needed.
4. Do not overturn back tilt knob when decreasing tension.
5. Dispose of packing material properly. Do not use plastic cover as head covering. It may cause suffocation.
6. Do not use chair as a stepladder.
7. Use this chair for its intended purpose only.
8. Use mild detergent only for cleaning.

### LIMITED WARRANTY

Pro-Line II chairs are warranted\* from the date of purchase against failure due to material and workmanship as follows:

- Lifetime on component parts including pneumatic cylinder, control mechanism, base and casters.
- 3 Years on upholstery fabric and foam against wear and deterioration.
- We can not warrant leather against routine scratching and scuffing, as all leather is subject to minor blemishes in normal use.

To make a warranty claim, contact Parts Department. Provide model number and description of the problem and obtain return authorization.

At it's option Office Star Products will:

- (a) Supply compatible components of current manufacture.
- (b) Repair the customer's component. The customer must prepay freight on any components returned to the factory.

Return freight on components still in warranty will be paid by Office Star Products.

\*All warranties are limited to the original purchaser for normal commercial usage defined as a standard forty hour work week by persons weighing 250 lbs. or less. This warranty will not cover labor, freight or damage from misuse, abuse, negligence, alteration, accident, vandalism, rusting, acts of nature or any other event beyond the control of Office Star Products. The warranty does not cover cosmetic damage that may result from normal use. Liability for incidental or consequential damages is excluded. The user assumes all risk of injury resulting from use of this product. When usage is more than 40 hours per week, a five year warranty on all parts applies. Fabric and foam is warranted for one year. This warranty gives you specific legal rights, and you may also have other rights which vary from state to state.

Our quality standards are among the highest in the industry. Sometimes, no matter how hard we try, there are times when parts are damaged or missing. Our Parts Department will do everything possible to promptly remedy the problem. Contact us via e-mail [parts@officestar.net](mailto:parts@officestar.net), by Fax 1-909-930-5629, or toll free parts number 1-800-950-7262, Monday through Friday 8:00 a.m. - 5:00 p.m. Pacific Time.

# 8000/8001 EXECUTIVE LEATHER CHAIR ASSEMBLY INSTRUCTIONS

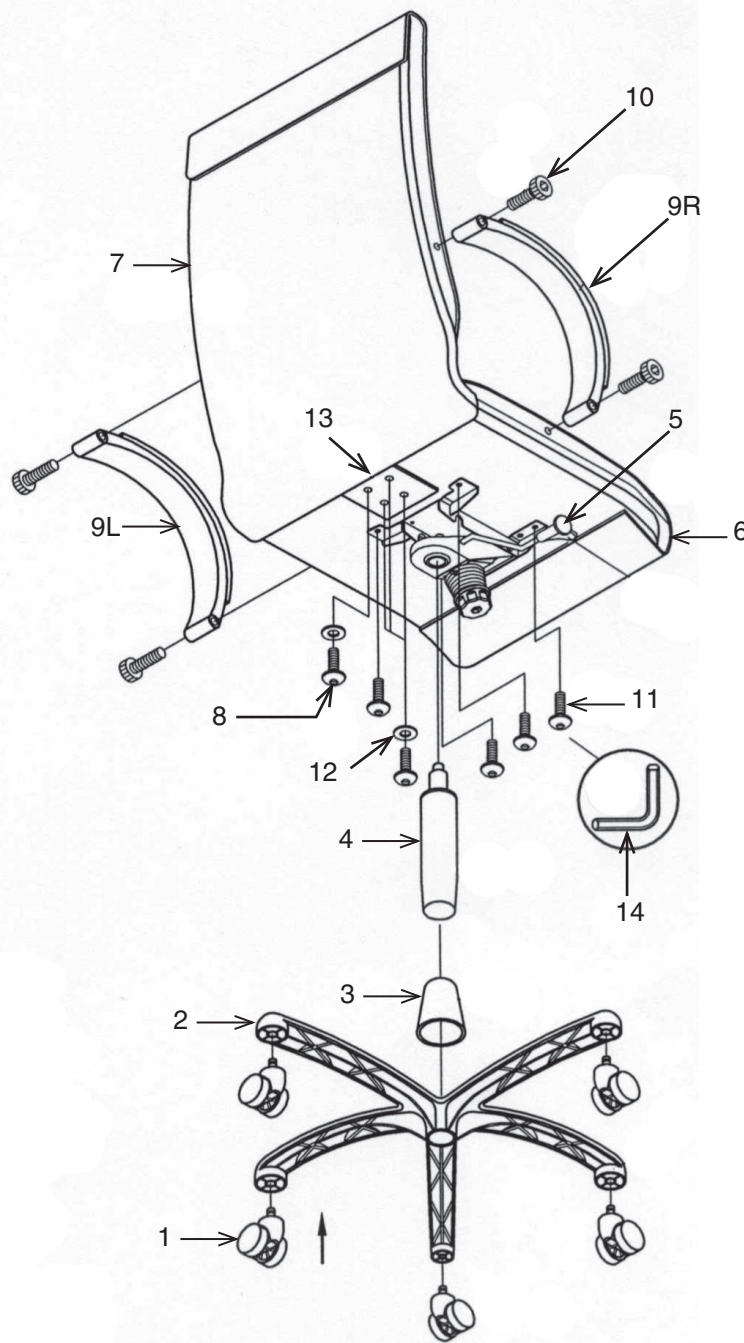

PART	QTY
1. Caster	5
2. Base	1
3. Bellows	1
4. Pneumatic Cylinder	1
5. Mechanism	1
6. Seat Cushion	1
7. Back Assembly	1
8. Backrest Screw	4
9. Arm (9L & 9R)	2
10. Arm Screw	4
11. Mechanism Screw	4
12. Washer	4
13. Back Support (Pre Installed)	1
14. Allen Wrench	1

Remove all parts from carton, separate by part numbers indicated on parts list, and verify part quantities.

**STEP 1** Insert five Casters (1) into Base (2), push hard until you feel or hear the Caster (1) snap into place. Insert Pneumatic Cylinder (4) through Bellows (3) into Base (2).

**STEP 2** Attach Back Support (14) to rear of Seat Cushion (6) using four Backrest Screws (8) and four Washers (12). Align holes in Arms (9L & 9R) with holes of Seat Cushion (6) and Back Assembly (7). Secure Arms (9L & 9R) using two Arm Screws (10) for each Arm (9R & 9L).

**FULLY TIGHTEN ALL SCREWS USING ALLEN WRENCH (14).**

**STEP 3** Attach Mechanism (5) to Seat Cushion (6) with arrow towards front of chair using four Mechanism Screws (11).

**FULLY TIGHTEN ALL SCREWS USING ALLEN WRENCH (14).** Place assembled seat on Pneumatic Cylinder (4) and apply downward pressure.

**ATTENTION: MAKE SURE ALL SCREWS ARE FULLY TIGHTENED BEFORE USING CHAIR.**