

Model 655 Vision Guest Chair

Parts Listing

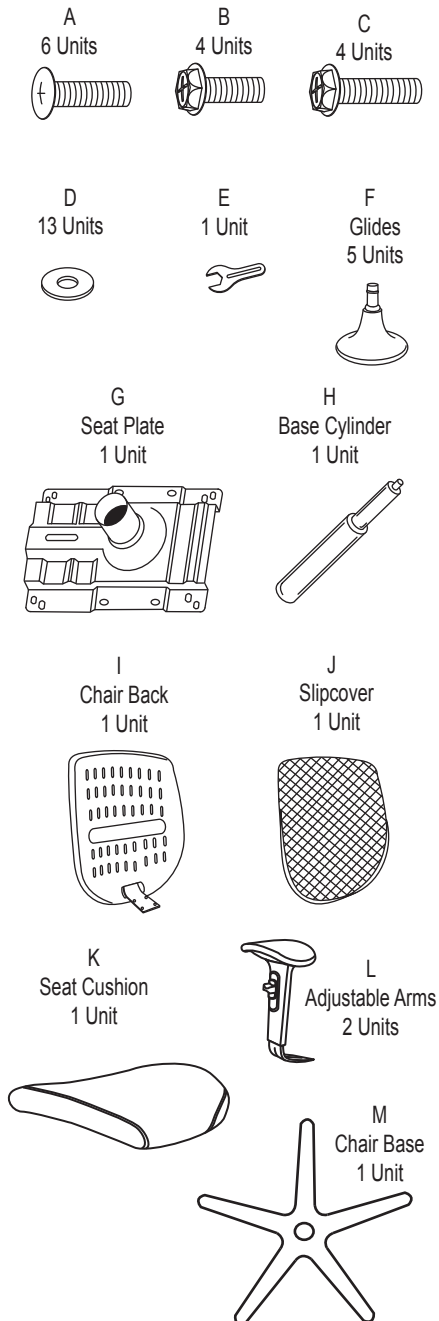

WEIGHT CAPACITY: 250 lbs.

Assembly Notes:

During assembly, hand tighten screw only when all screws are in place, you may then tighten all screws completely.

CAUTION:

1. Do not use this chair as a step ladder.
2. Check for loose screws and tighten them every 6 months.

Assembly Instructions



Tools Needed: Phillips Head Screwdriver
Please read all instructions before assembly.

- Step 1:** Insert Glides (F) into Chair Base (M). Insert Base Cylinder (H) into Chair Base (M).
- Step 2:** Attach Adjustable Arms (L) to Seat Cushion (K) using screws (A) and washers (D). Tighten screws with phillips head screwdriver.
- Step 3:** Cover plastic Chair Back (I) with replaceable Slipcover (J), and place mount plate through slipcover before securely zipping.
- Step 4:** Align mounting plate on Chair Back (I) with pre-drilled holes under Seat Cushion (K) and attach with 4 Bolts (C) and Washers (D), using Wrench (E) that is provided.
- Step 5:** Attach Seat Plate (G) to the Seat Cushion (K) with 4 Bolts (B) and washers (D), using the Wrench (E) that is provided.
- Step 6:** Take entire chair frame and place Seat Plate (G) onto Base Cylinder (H), and press down firmly to secure.

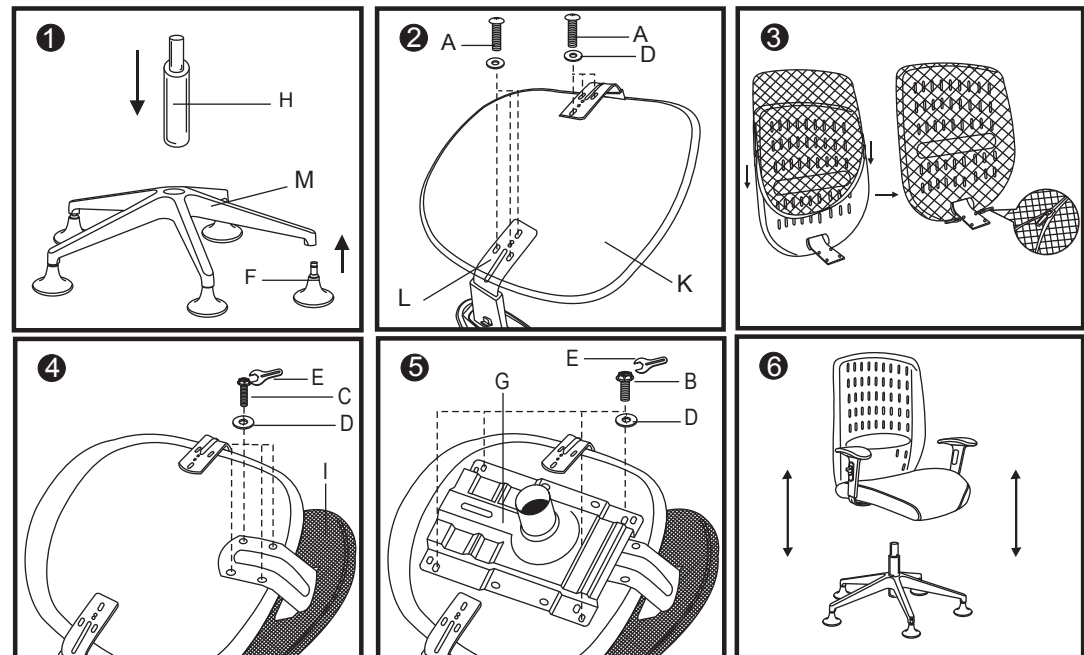

161 Tradition Trail Holly Springs, NC, 27540
 800-520-7471 (voice) 919-362-4765 (fax)
 919-303-6389 (voice) www.ofminc.com
 support@ofminc.com