

# Model 591-F / 591-L Ultimate Executive Fabric/Leather & Mesh Mid-Back Chair

## Parts Listing

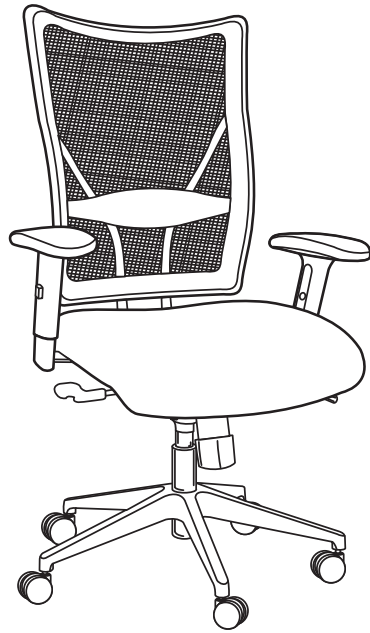

## Assembly Instructions

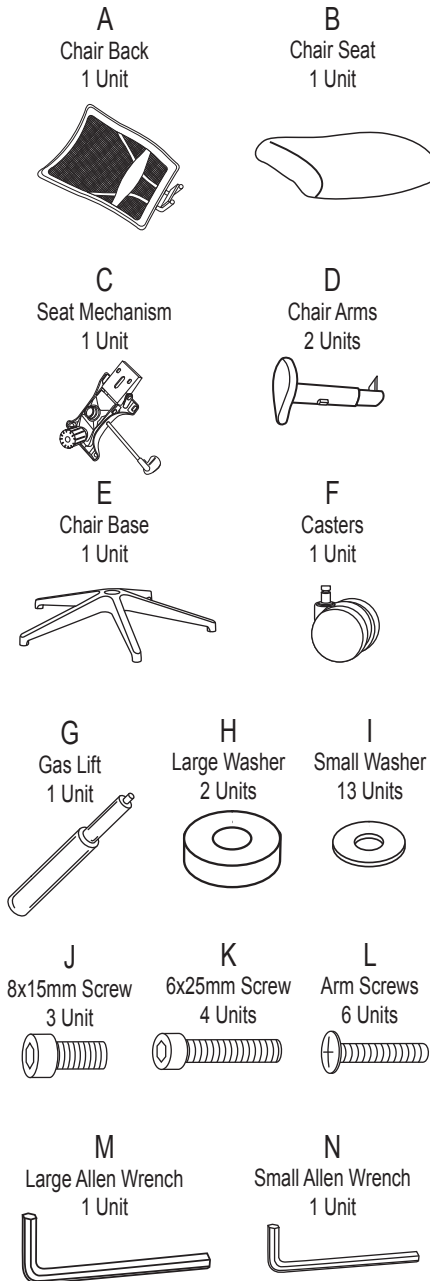

**Tools Needed: Phillips Head Screwdriver**  
*Please read all instructions before assembly.*

- Step 1:** Insert Casters (F) into Chair Base (E). Insert Gas Lift (G) into Chair Base (G).
- Step 2:** Attach Chair Arms (D) to Chair Seat (B) by placing Large Washers (H) between the Chair Seat (B) and the Chair Arms (D), aligned with the inside hole on arms. Then with one Small Washer (I) on each Arm Screws (L), insert screws through the holes in the Chair Arms (D) and into the Chair Seat (B).
- Step 3:** Attach Seat Mechanism (C) to Chair Seat (B) by inserting four 6x25mm Screws (K), and Small Washers (I) through holes in the Seat Mechanism (C) and into the Chair Seat (B), using Small Allen Wrench (N) provided.
- Step 4:** Insert mounting plate on Chair Back (A) into back of Seat Mechanism (C) and attach with three 8x15mm Screws (J), using Large Allen Wrench (M) that is provided.
- Step 5:** Take entire chair frame and place Seat Mechanism (C) onto Gas Lift (G), and press down firmly to secure.

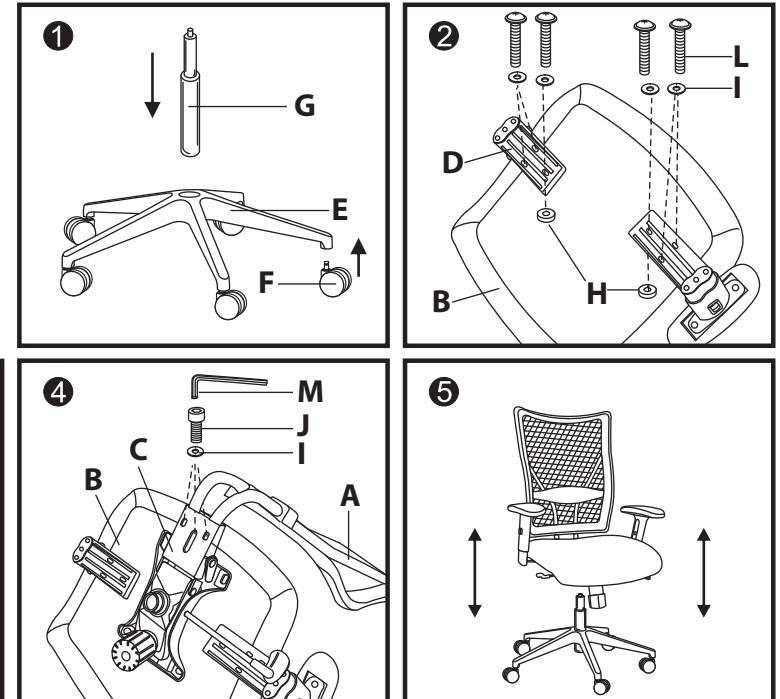

**WEIGHT CAPACITY: 250 lbs.**

### Assembly Notes:

During assembly, hand tighten screw only when all screws are in place, you may then tighten all screws completely.

### CAUTION:

1. Do not use this chair as a step ladder.
2. Check for loose screws and tighten them every 6 months.

**ofm**  
Furniture For The Real Office™

161 Tradition Trail Holly Springs, NC, 27540  
800-520-7471 (voice) 919-362-4765 (fax)  
919- 303-6389 (voice) www.ofminc.com  
support@ofminc.com