

Model 420 UNO Lounge Chair

Parts Listing

A
Back Cushion
1 Unit

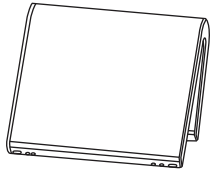

B
Seat Cushion
1 Unit

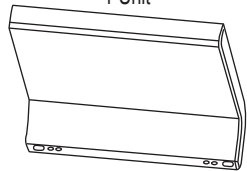

C
Frame / Legs
2 Units

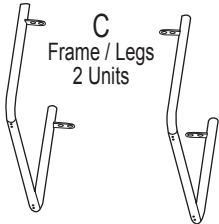

D
Screws
8 Units



F
Ganging Bracket Screw
2 Units



E
Ganging Brackets
2 Sets

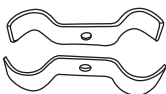

G
Ganging Bracket Nut
2 Units



5mm Allen Wrench
1 Unit

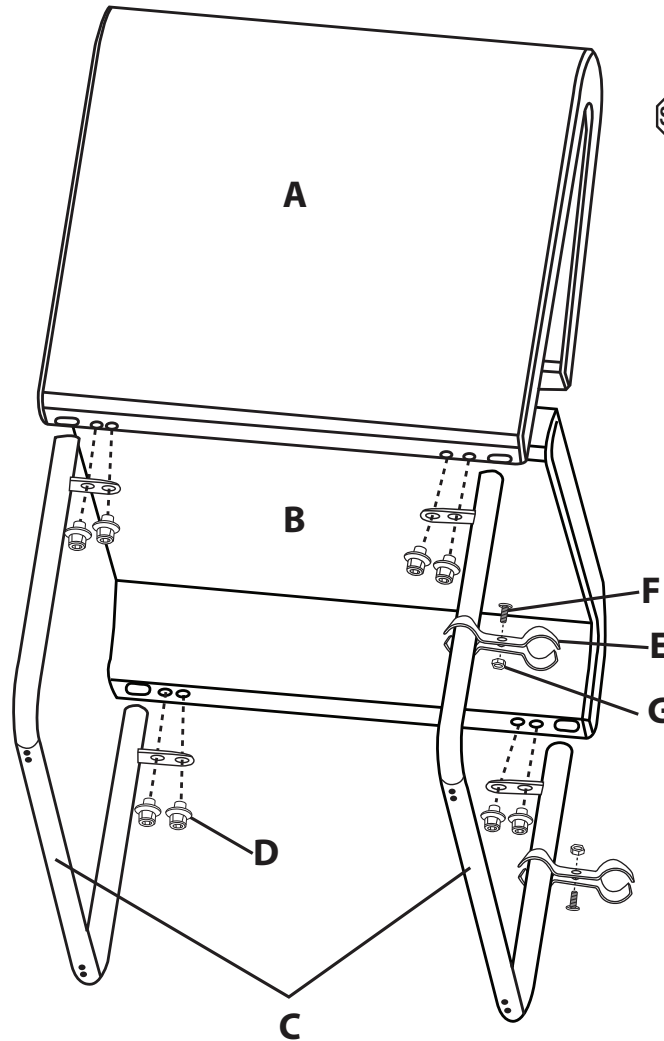
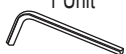

WEIGHT CAPACITY: 250 lbs.

Assembly Notes:

During assembly, hand tighten screw only. When all screws are in place, you may then tighten all screws completely.

CAUTION:

1. Do not use this chair as a step ladder.
2. Check for loose screws and tighten them every 6 months.



Assembly Instructions

Tools Needed: Allen Wrench and a Standard Screw Driver.

Step 1: Insert the Frame/Legs (C) into the large holes in the Back Cushion (A) and the large holes in the Seat Cushion (B) as shown.

Step 2: Align the holes in the Frame/Legs (C) with the corresponding holes in the Back Cushion (A) and Seat Cushion (B).

Step 3: Insert Screws (D) through the holes in the Frame/Legs (C). Tighten by hand.

Step 4: When all screws are in place, tighten with Allen Wrench.

Step 5: If applicable, attach Ganging Bracket (E) to Frame/Legs (C) using Ganging Bracket Screw (F) and Ganging Bracket Nut (G). Tighten using Screw Driver.



Follow us on facebook at facebook.com/ofmnc



Tweet with us on twitter at twitter.com/ofmnc



Watch us on youtube at youtube.com/ofmnc

ofmnc
Furniture For The Real Office™

161 Tradition Trail • Holly Springs, NC, 27540
800-520-7471 (voice) • 919-362-4765 (fax)
919-303-6389 (voice) • www.ofmnc.com
support@ofmnc.com