

Model 521-LX / 521-LX-AA Stimulus Leatherette Mid-Back Chair

Parts Listing

A
Chair Back
1 Unit

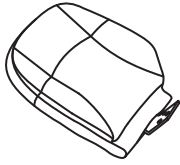

B
Chair Seat
1 Unit



C
Chair Base
1 Unit



D
Seat Mechanism
1 Unit

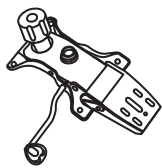

E
Gas Lift
1 Unit

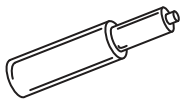

F
Telescopic Bellows
1 Unit

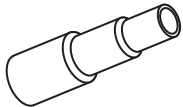

G
Casters
5 Units



H
Mechanism Screws
4 Units

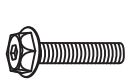

I
Back Screws
3 Units

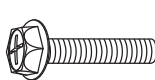

J
Washer
3 Units



K
Small Wrench
1 Unit



L
Large Wrench
1 Unit



Assembly Instructions



Tools Needed: Large and Small Allen Wrench (provided)
Please read all instructions before assembly.

Step 1: Insert Casters (G) into Base (C). Insert Gas Lift (E) into Base (C), and cover with Telescopic Bellows (F).

Step 2: Place Chair Seat (B) upside-down on a level, non-abrasive surface and align pre-drilled holes in Seat Mechanism (D), with holes in Chair Seat (B). The thinner portion of seat should face the back. Insert four Mechanism Screws (H) through the holes in the Seat Mechanism (D) and into the Chair Seat (B). Tighten with Small Wrench (K).



If you are assembling a model with optional Adjustable Arms please proceed to subsequent pages for armrest assembly instructions.

Step 3: Connect Chair Back (A) to Chair Seat (B) by inserting the J-bar on the Chair Back into the back of the Seat Mechanism (D). Then attach by inserting three Back Screws (I) through Washers (J) using the Large Wrench (L).

Step 4: Carefully place Chair Seat (B) with attached Seat Mechanism (D) onto the Gas Lift (E) by aligning the hole in the Seat Mechanism (D) with the top of the Gas Lift (E). Carefully sit on chair to make sure the Gas Lift (E) is properly inserted into the Base (C). Operate the Gas Lift Lever on the Seat Mechanism (D) to be sure unit is working.

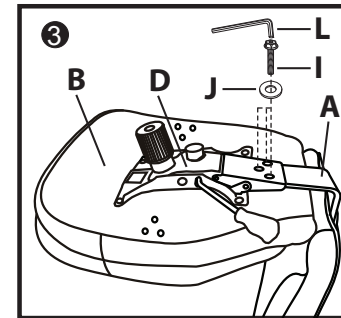
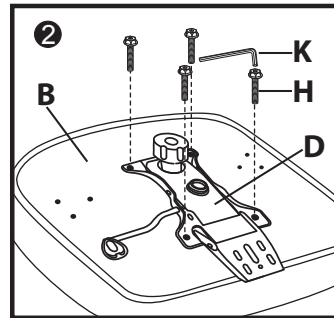
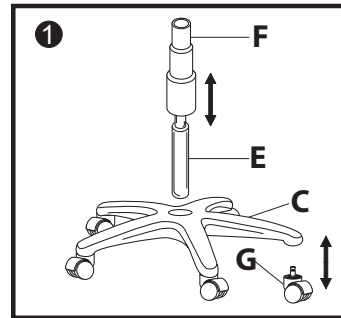

WEIGHT CAPACITY: 250 lbs.

Assembly Notes:

During assembly, hand tighten screws only. When all screws are in place, you may then tighten all screws completely.

CAUTION:

1. Do not use this chair as a step ladder.
2. Check for loose screws and tighten them every 6 months.

ofm
Furniture For The Real Office™

161 Tradition Trail, Holly Springs, NC, 27540
800-520-7471 (voice) 919-362-4765 (fax)
919-303-6389 (voice) www.ofminc.com
support@ofminc.com

Model AA-1 Adjustable Arms

Parts Listing

A

AA-1 Adjustable Armrest
2 Units

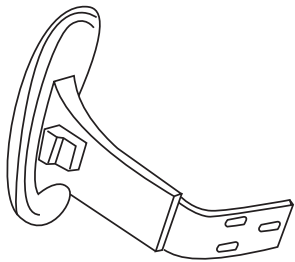

B

M6x25mm Hex Screw
6 Units

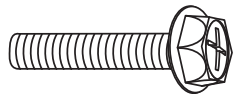

C

Washer
6 Units

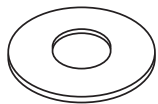

D

Wrench
1 Unit

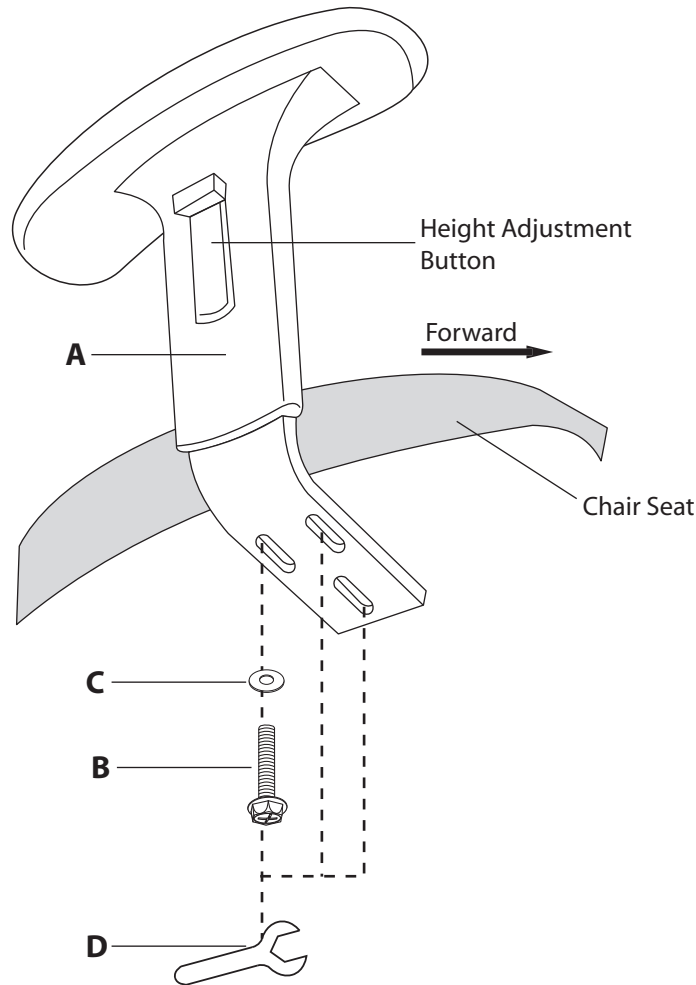
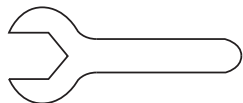

Assembly Instructions



Tools Needed: Phillips Head Screwdriver

Please read all instructions before assembly.

- Step 1:** Turn Chair Seat upside down and place on a clean, non-abrasive surface.
- Step 2:** Align the pre-drilled holes in the Adjustable Armrest (A) with the holes in the bottom of the Chair Seat, making sure that the arms have the height adjustment buttons facing out.
- Step 3:** Place three Washers (C) onto three M6x25mm Hex Screws (B) and insert through the Armrest (C) holes and into the Chair Seat.
- Step 4:** Tighten Screws (B) using supplied Wrench (D) or screwdriver. It is recommended that to assure screws are secure, a screwdriver is used to tighten.

To Adjust Arms:

Pull up on the Height Adjustment Button and slide to desired height.

Assembly Notes:

During assembly, hand tighten screws. Only when all screws are in place, you may then tighten all screws completely.

CAUTION:

1. Do not use this chair as a step ladder.
2. Check for loose screws and tighten them every 6 months.

ofm^U_Z
Furniture For The Real Office™

161 Tradition Trail Holly Springs, NC, 27540
800-520-7471 (voice) 919-362-4765 (fax)
919-303-6389 (voice) www.ofminc.com
support@ofminc.com