

Bristol Island Light



Specifications

Material Construction:	Formed Steel
Lens:	Alabaster glass
Lamp Type & Wattage:	Two 60W, medium base incandescent lamps
Mounting:	Ceiling mounted
Finish:	Satin Nickel (US15)
Voltage:	120V
Weight:	12.5 lbs.
Companion Fixtures:	Chandeliers, wall mounts, pendants & ceiling mounts



Dimensions

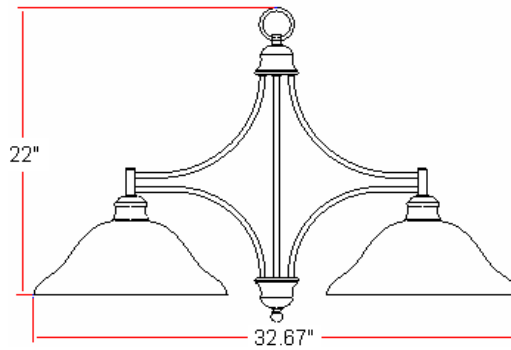

Warranty & Compliances

Warranty	10 Year Limited Warranty
UL	UL/cUL listed
ADA	N/A
EnergyStar	N/A



Companion Fixtures

Island Light	517110	
1 LT Wall Mount	516666	
2 LT Wall Mount	517086	
3 LT Vanity Light	510263	
4 LT Vanity Light	517128	
2 LT Flush Mount	510297	
3 LT Chandelier	510321	
5 LT Chandelier	510255	
9 LT Chandelier	517136	
Pendant	517102	
Mini Pendant	517094	

Type:

Job:

Order Code:

Approvals:

Design House reserves the right to make changes in materials, specifications & models at any time. Design House also reserves the right to discontinue product without notice or obligation.