

# 1 LT WHITE W/OPAL GLS/PULL CHAIN CEILING MOUNT



## Specifications

<b>Material Construction:</b>	Formed Steel
<b>Lens:</b>	Opal glass
<b>Lamp Type &amp; Wattage:</b>	One 60W, medium base incandescent lamp
<b>Mounting:</b>	Ceiling mounted
<b>Voltage:</b>	120V
<b>Weight:</b>	0.78 lbs
<b>Other:</b>	Pull Chain On/Off control



## Dimensions

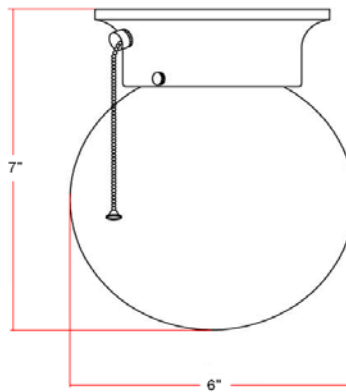

## Warranty & Compliances

<b>Warranty</b>	10 Year Limited Warranty
<b>UL</b>	UL/cUL listed
<b>ADA</b>	N/A
<b>EnergyStar</b>	N/A



## Order Code

White 510040



Type:

Job:

Order Code:

Approvals:

Design House reserves the right to make changes in materials, specifications & models at any time. Design House also reserves the right to discontinue product without notice or obligation.