

INSTALLATION AND OWNER'S MANUAL

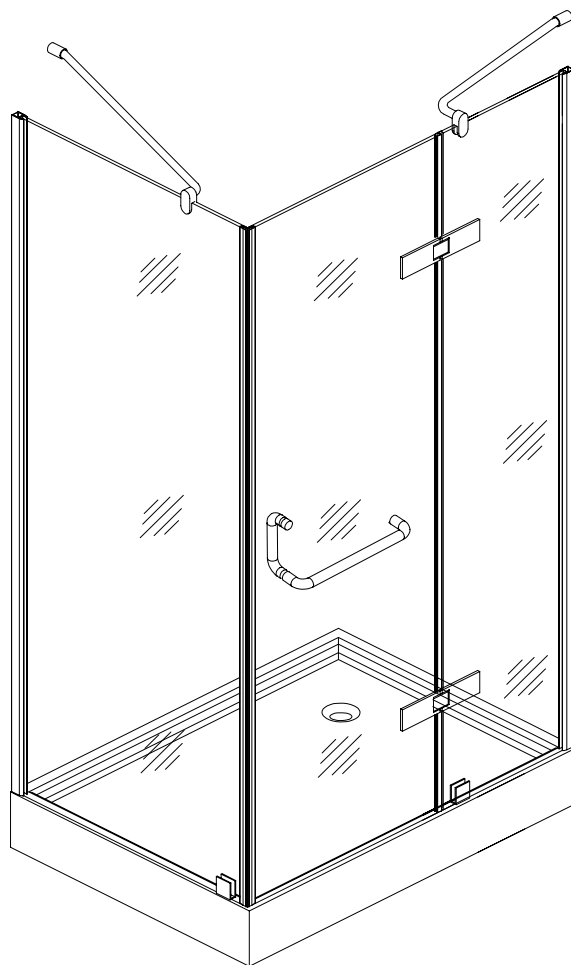

Shower Door Model Number: SD974-R

Please carefully read these instructions before you begin to install the products.

01/12 Rev B
P/N: 10055-10

Before you start



Thank you for purchasing your Aston shower door and tray. We hope that it will provide you with years of satisfying use and enjoyment.

Please read this manual carefully because it contains information and instructions about the proper installation of the unit. If you do not follow certain conditions of installation and maintenance, your warranty may be affected.

Aston Shower door's and shower tray's feature:

- ✓ Tempered Safety Glass
- ✓ High quality hardware
- ✓ Easy maintenance durable fiberglass reinforced acrylic

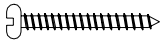
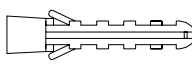
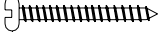
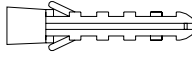
SUPPLIED HARDWARE

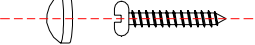
SCREW PACK (1)	M4x40		8
	Expand tube		8
SCREW PACK (2)	M4x40		2
	Expand tube		2
	M5x20		2
SCREW PACK (3)	M4x12		6

SUPPLIED PARTS

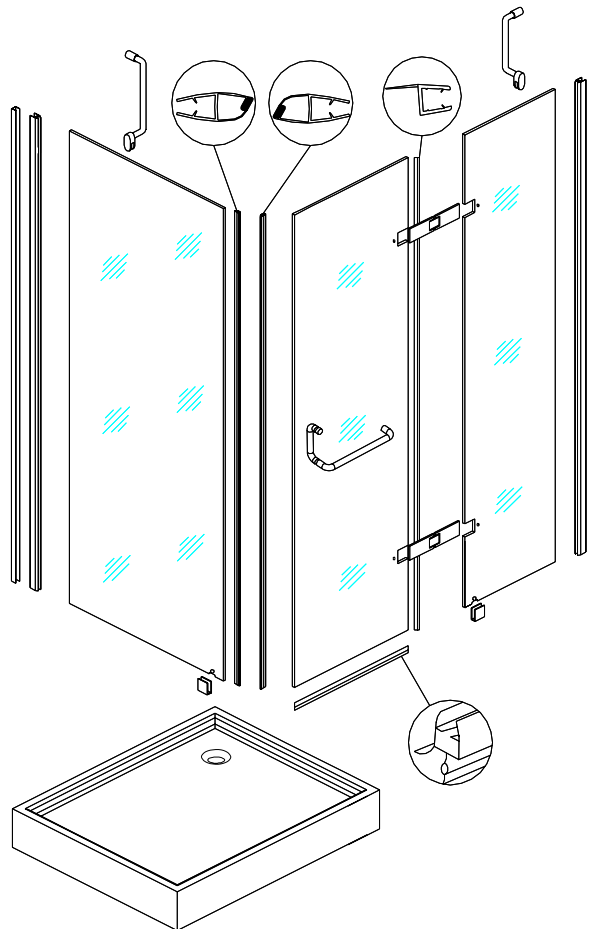

Installation Guide

Please read and follow the installation instructions and guidelines in this section. Failure to follow the recommended instructions and installation techniques may lead to possible damage to the unit or the surrounding area and can affect warranty claims.

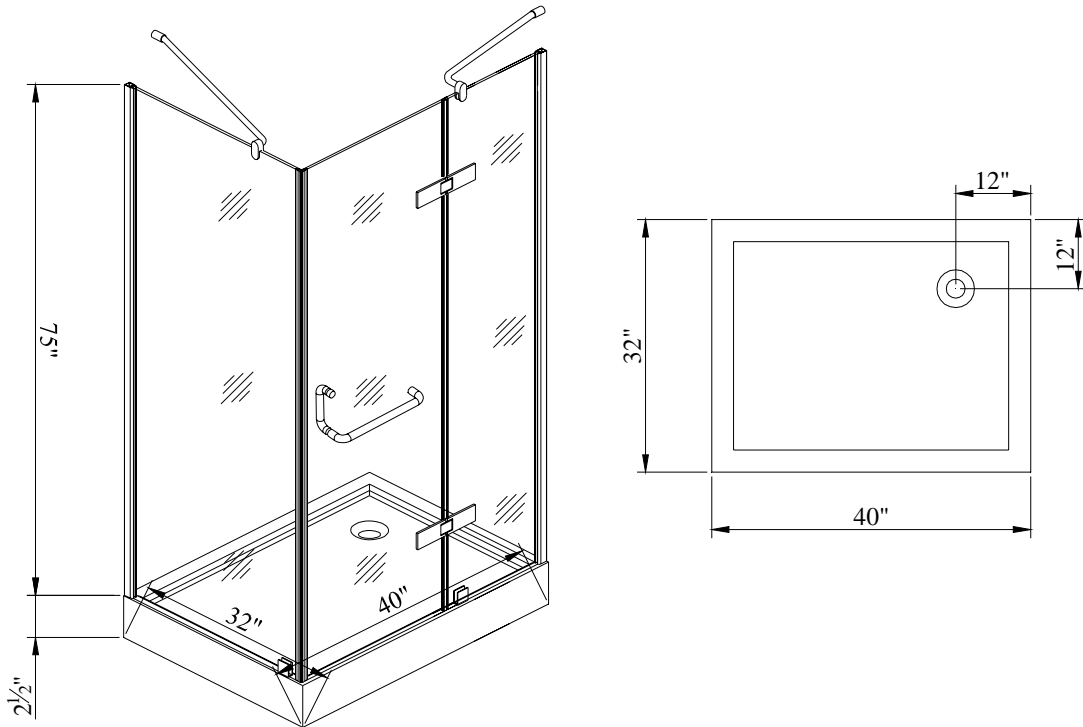

ATTENTION: This unit requires assembly. A minimum of two people are required for assembly, as several of the sections can be large and unstable until assembled.

You will need the following tools:

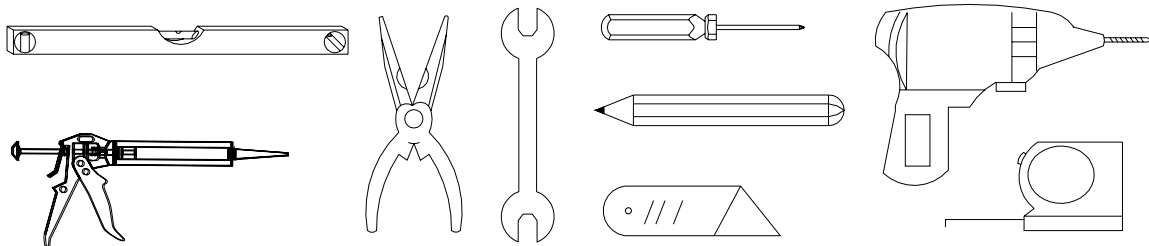

- ✓ Drill with screwdriver attachments
- ✓ Caulk gun
- ✓ Level (3 foot or longer is recommended)
- ✓ Tape measure
- ✓ Phillips head screw driver
- ✓ Flat head screw driver

✓ Bathroom rated silicone sealant

Before starting the installation, please ensure that you have inspected all components of the unit and check for broken or damaged sections. If you find damage, please contact your dealer or the manufacturer.

Locate the accessory and manual box and remove the individual screw and hardware packages and lay them out in sequential order to aid in completing the rest of the installation

Preparation of base for installation of shower tray

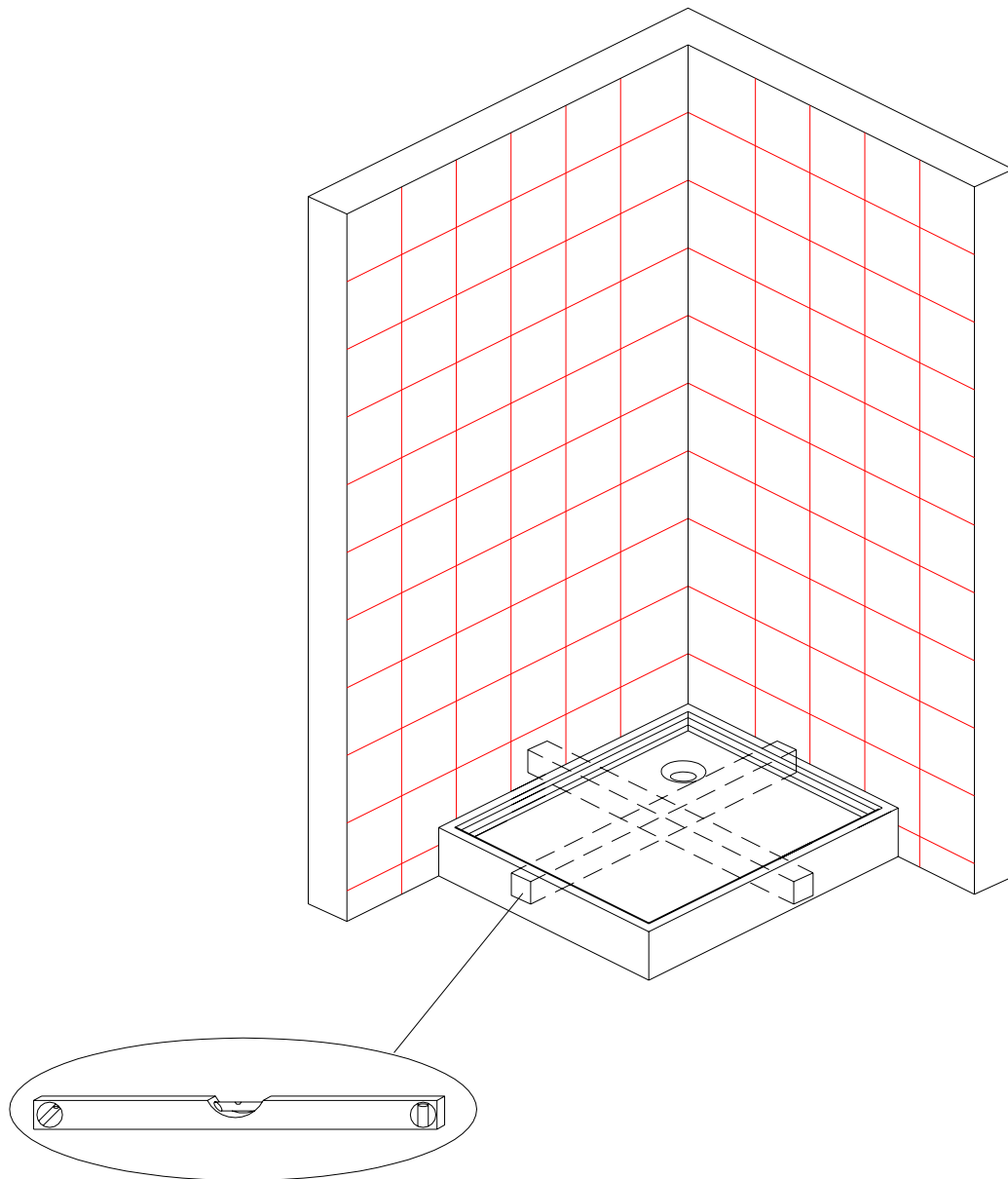

The shower tray needs to sit on a flat level base for proper support. Ensure that the area for the shower tray is properly prepared for installation.

Using the drawing provide place the floor drain in the proper location so that the shower tray drain and the floor drain are in line after final installation .

Place the shower tray in the final installation position line up the drain holes and check for level. If not level make adjustments to the floor at this time.

Mark the wall channel mounting holes

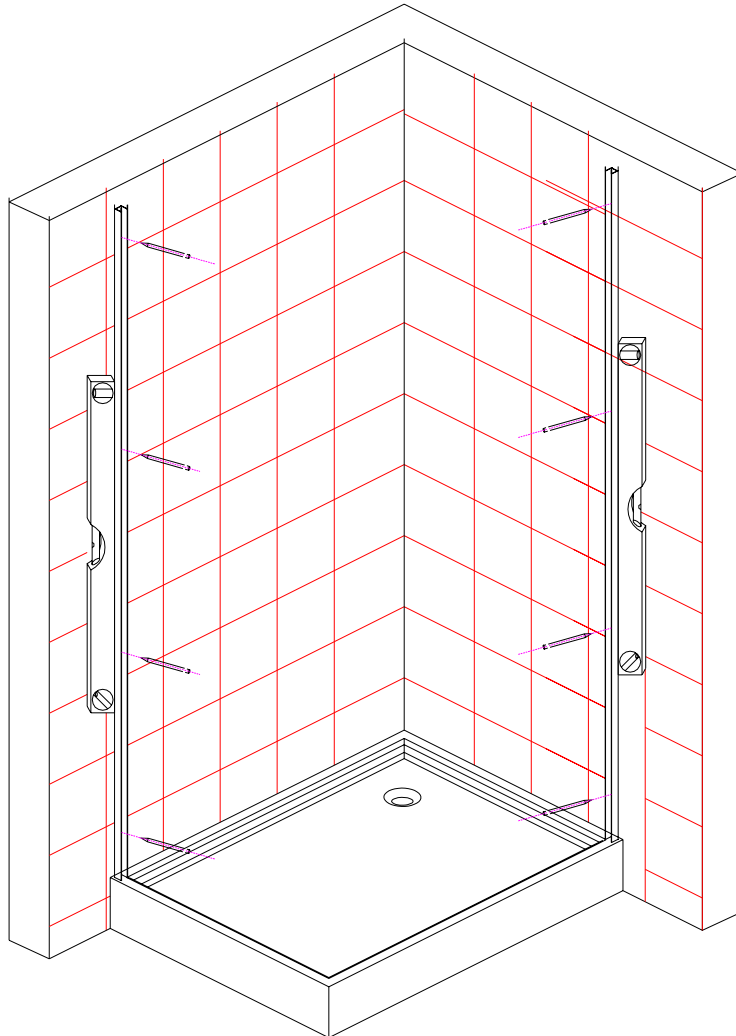

Install all of the wall material or materials you intend to use before installing the wall channels this includes all moisture resistant wall board or rock board, tile, stone or other wall covering.

Place the wall channel so that the center of the channel 1-3/8 inch off from the front edge of the shower tray if you are using an Aston supplied shower tray. With the wall channel at the proper location and flush to the acrylic base use a level to plumb the wall channel and mark the mounting holes. Repeat the process for the other side.

Drilling and installing the wall anchors

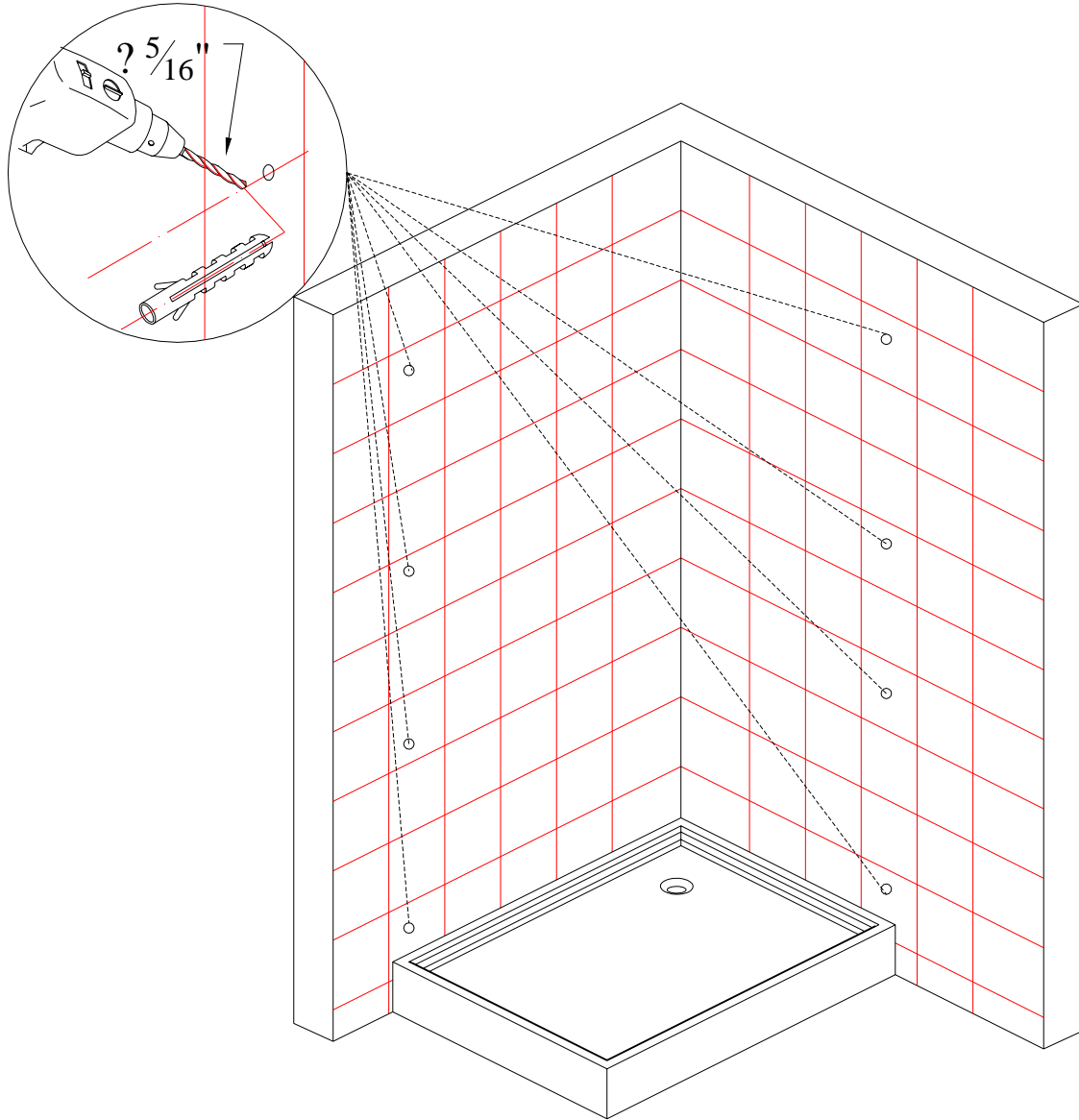

Using the appropriate drill bit for your wall surface drill each hole location with a $\frac{5}{16}$ " diameter drill bit. Install the plastic wall anchors provided into the drilled holes

NOTE: If your surface is prone to cracking or chipping then it is recommended that you pilot drill first using a smaller drill bit, and then step up to the final size.

Mounting the wall channels

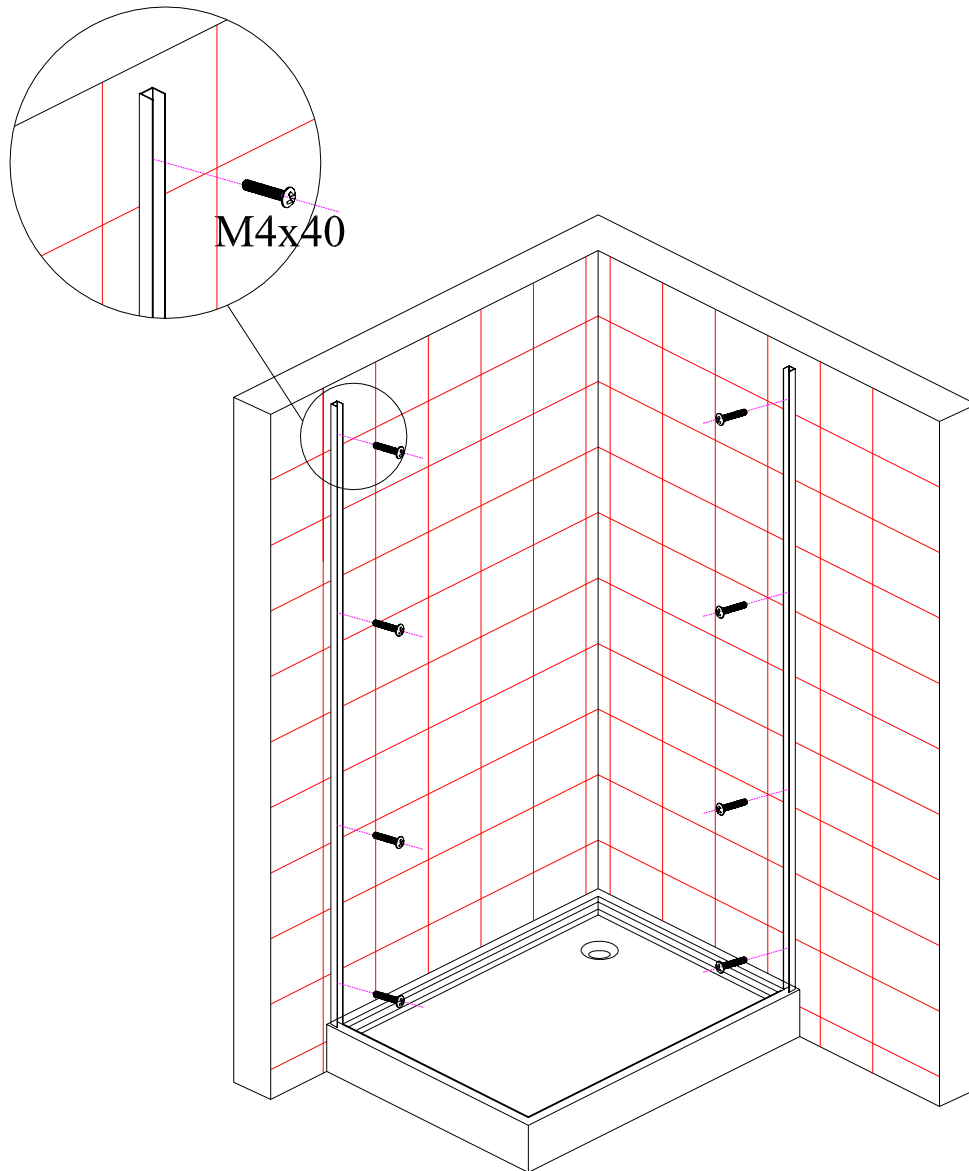

SCREW PACK
(1)

Mount the wall channels to the wall using the screws provided.

Installing the fixed glass panels

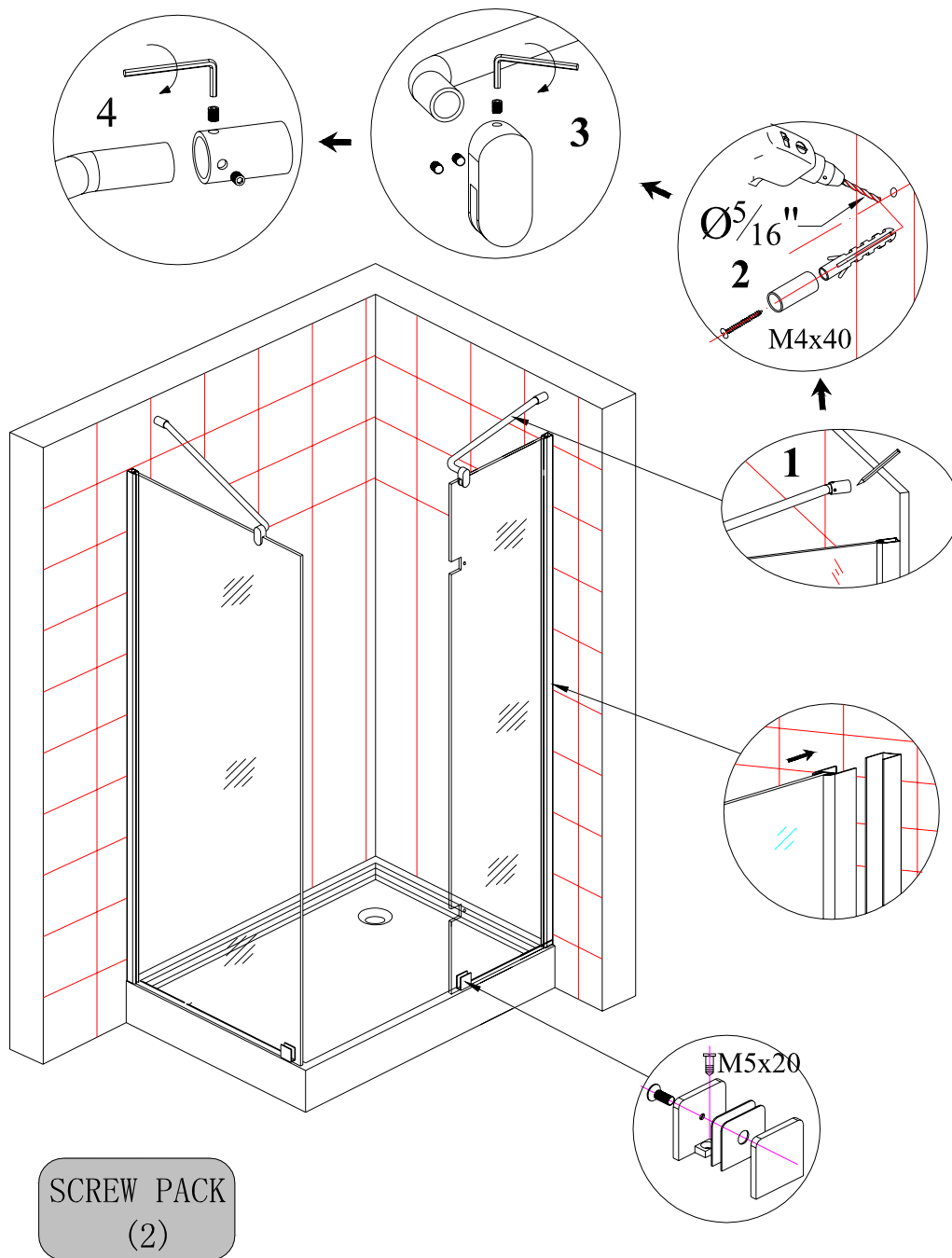

The fixed glass panel has a female channel for the wall channel to slide into. The fixed glass wall channel will install over the mounted wall channel. Slide the fixed glass panel over the mounted wall channel. Repeat installation for the other side.

Locate the brackets for the bottom of the fixed glass panels in the Accessory box this unit uses 2 brackets one on each panel.

Place the bracket into slot at the bottom of the fixed glass panel center with the glass and mark the mounting hole. After marking remove the bracket and slide the fixed glass panel towards the interior of the unit to gain access to drill a pilot hole for the mounting screw.

Using a 1/8" drill bit drill the pilot hole for the mounting screw. Place a small amount of silicone to the bottom of the bracket and install onto the shower tray using the mounting screw provided.

Slide the fixed glass panel back into place and install the remaining components of the bracket use the 2 silicone flat washers provided and hardware.

Repeat this process for the other fixed glass panel.

Next locate the braces for the top of the fixed glass panels also located in the Accessory box this unit uses 2 braces.

Assemble one of the braces installing both end mounting brackets onto the rod see drawing for configuration.

Place the assembled rod onto one of the fixed glass panels and move the brace until the brace is flush against the wall and is fully installed onto the glass panel.

Using an erasable pencil mark the location of the brace on the wall.

Repeat this process on the other glass panel.

Using the appropriate drill bit for your wall surface drill each mounting location with a 5/16 diameter drill bit. Install the plastic wall anchors provided into the drilled hole.

NOTE: If your surface is prone to cracking or chipping then it is recommended that you pilot drill first using a smaller drill bit and then step up to the final size.

Finally install the rubber magnet seals on the fixed glass panels.

Installing the door

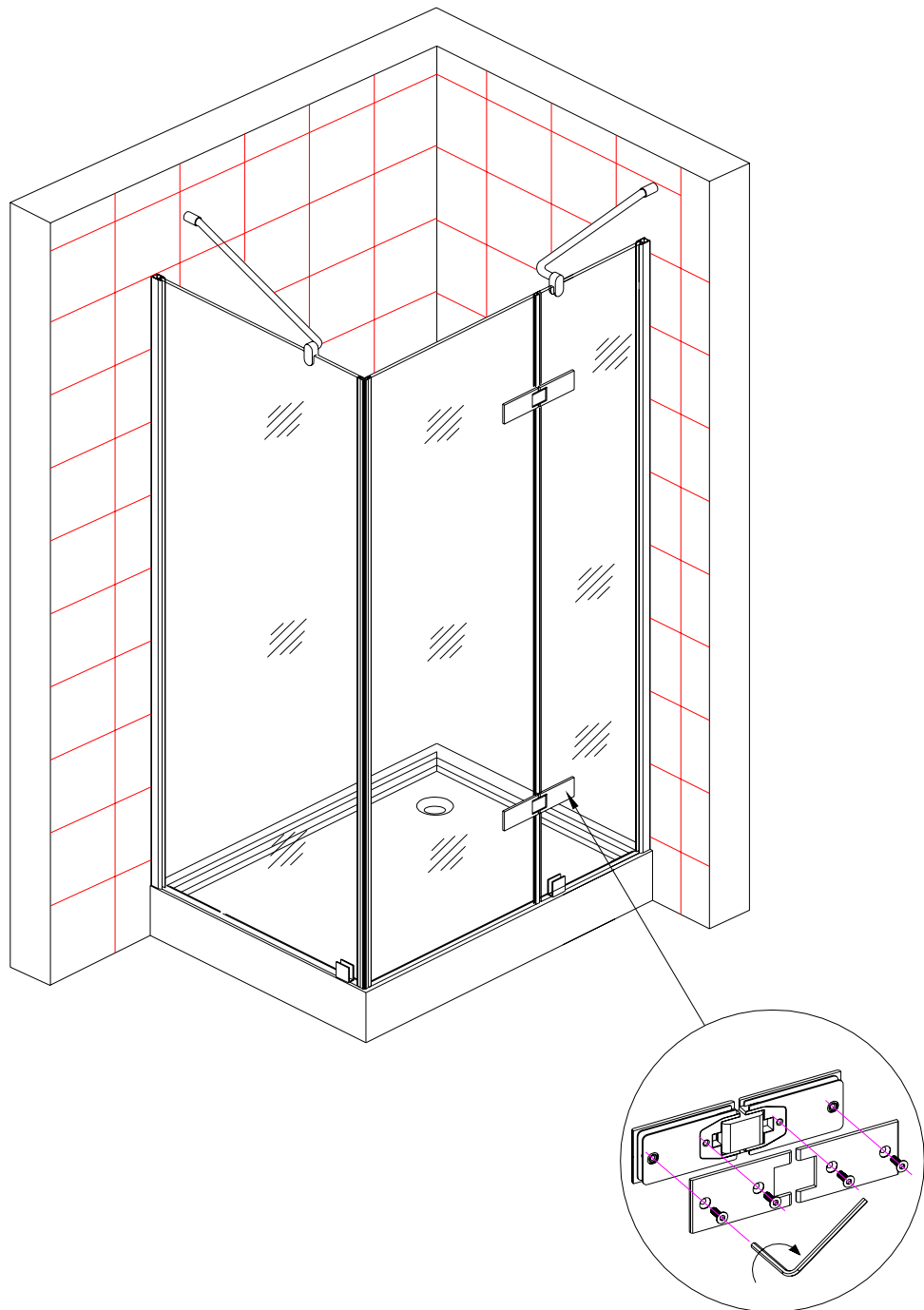

Using the hardware provided install the hinges .

Secure the fixed glass panel to the wall

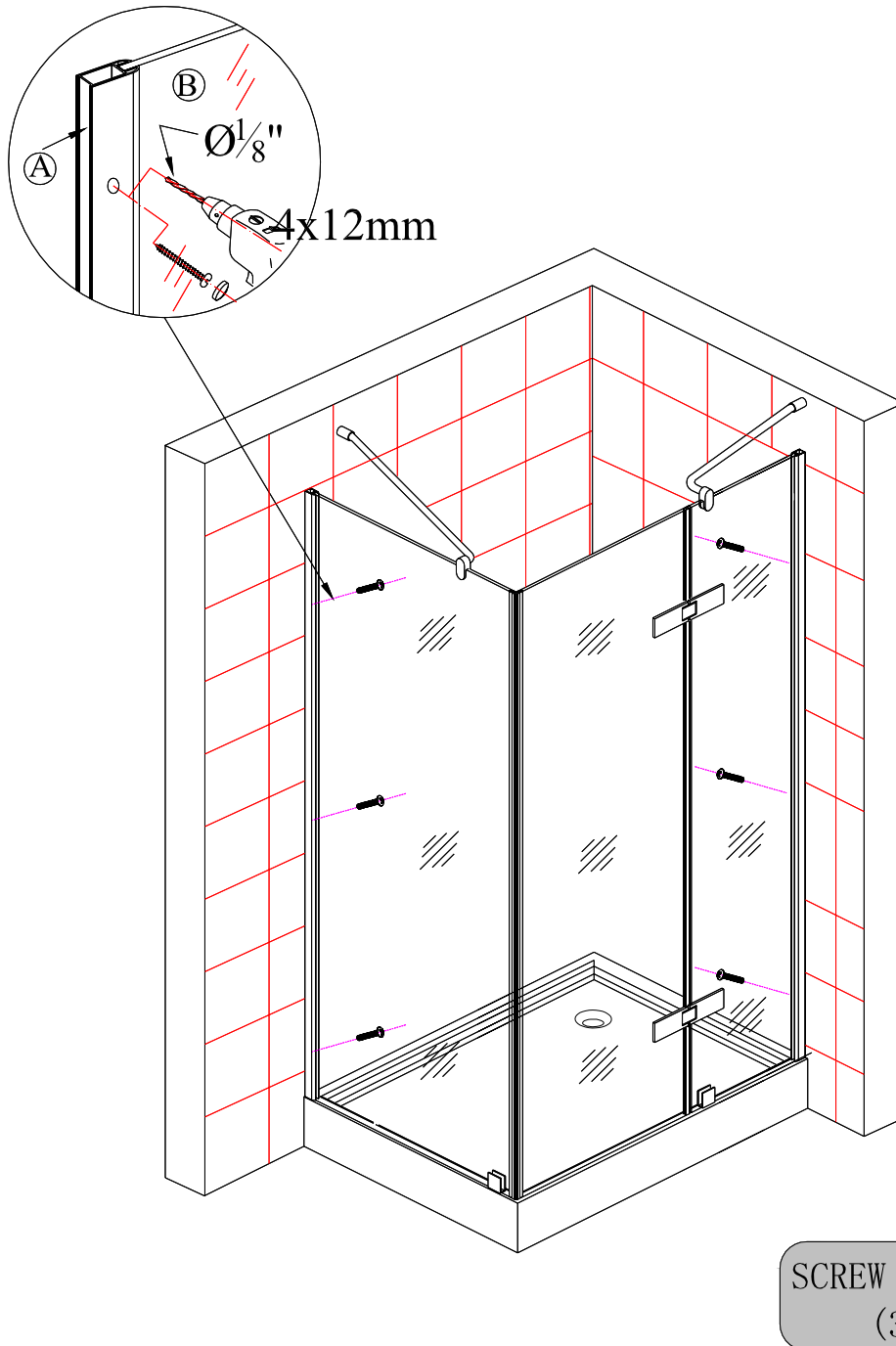

Use a 1/8 inch diameter drill bit and drill 3 equally spaced holes along each wall channel on the inside of the shower. Do not drill all the way thru to the other side drill only until the drill bit enters the void in the wall channel. Using the hardware provided secure the fixed glass panel to the wall channel. Repeat on the other side. Decorative covers are also provided to cover the screw heads.

Installing the door seals

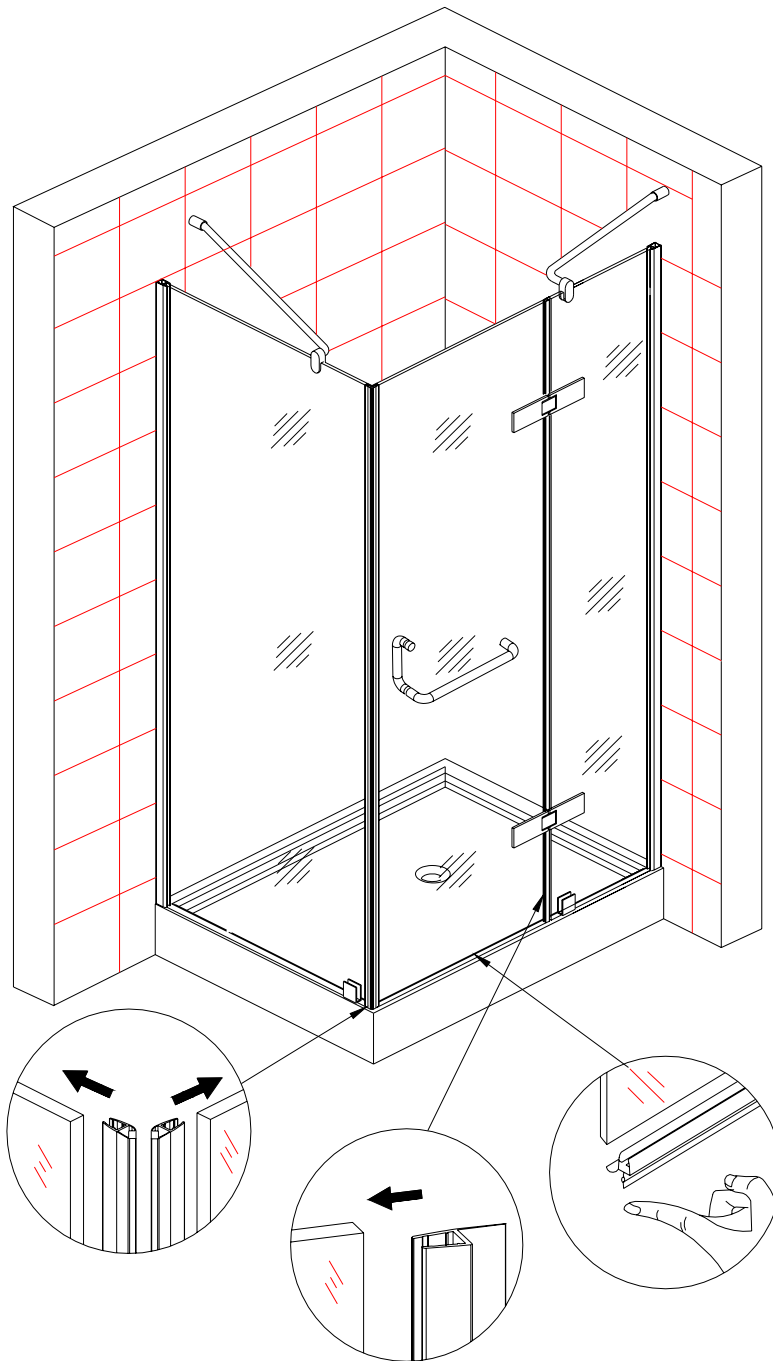

Install the bottom seal and the side magnet seal on the door. Once you have installed all of the seals close to door and ensure a seal is created the entire length of the door. Make adjustments if necessary to the door to create a positive seal.

Installing the door handle

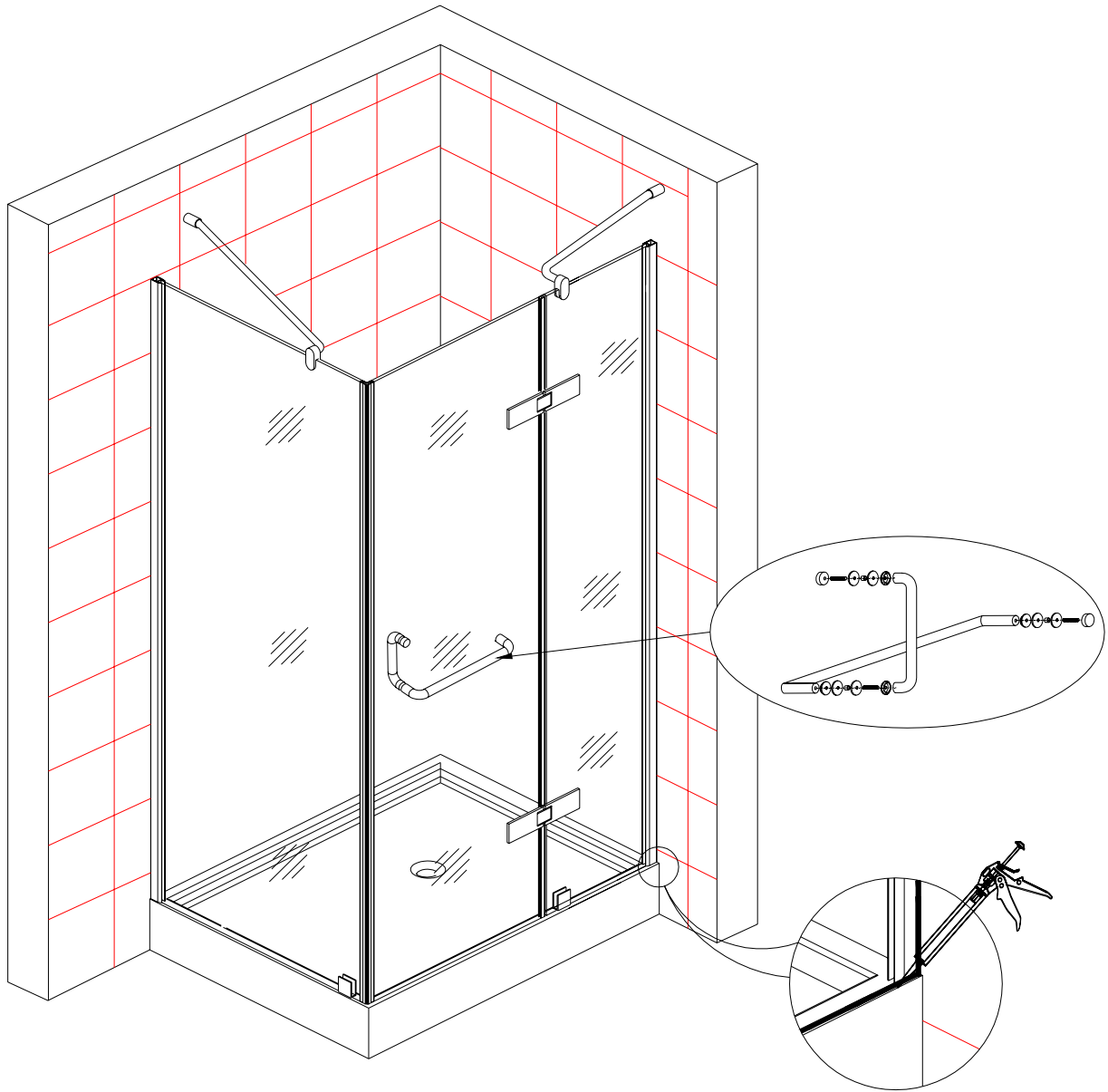

Install the door handle using the hardware provided be sure to use the silicone washer provided between the glass and the door handle to prevent scratching.

Final sealing

Using bathroom rated silicone sealant or caulk seal the bottom of each fixed glass panels to the shower tray and seal along each wall channel where the wall channel meets the wall.

Care and Maintenance

As with any other luxury item, maintenance and care are critical to the long lasting quality and enjoyment of your shower door and tray. The proper care and maintenance outlined in this section are necessary to ensure the longevity of the unit. Damage caused by not following the care and maintenance guidelines in this section is not covered under the manufacturer's warranty.

The unit is constructed from high quality acrylic and with proper care the unit will maintain its nice look and finish.

IMPORTANT: Never use an abrasive cleaner such as Comet or Ajax to clean the acrylic surface. These cleaners will scratch the surface and dull the finish. In addition, do not use any of the following products to clean the acrylic surface:

- Y Acetone
- Y MEK
- Y Mineral spirits
- Y any other solvent based cleaner

You can clean the acrylic surface with a mild non-abrasive cleaner such as Soft Scrub or other cleaning products formulated for acrylic surfaces.

You can buff and polish the acrylic surface using any good polishing compound such as Maguire's #10 Mirror glaze, toothpaste, or automotive polishing paste. Using these types of products will help maintain the shine and luster of the acrylic surface.

If you happen to discover any small minor surface scratches in the acrylic, you can use 600# grit wet sand paper to lightly buff out any scratches, and then use a surface polish to restore the shine and luster.

For deep scratches or chips where material has been removed, purchase an acrylic repair kit, which is available through hardware stores and home centers. Read and follow all of the instruction contained in the kit.

The glass doors and panels can be cleaned using any commercially available glass cleaner.

We recommend that you clean the glass daily and squeegee the glass with a silicone or rubber squeegee after each use to help prevent water spots.

Warranty

PLEASE READ THESE WARRANTY TERMS AND CONDITIONS CAREFULLY BEFORE USING YOUR ASTON GLOBAL BATHROOM PRODUCT. BY USING THE PRODUCT, YOU ARE CONSENTING TO BE BOUND BY THE FOLLOWING WARRANTY TERMS AND CONDITIONS.

SHOWER DOOR/SHOWER TRAY

Aston Global Inc. Parts-Only Limited Warranty 5 years

Aston Global, Inc. ("Aston Global") warrants to the original retail purchaser ("Owner") of any Shower Door/Tray product ("Product"), at the original installation site, for a period of Five (5) years from date of purchase (whether directly from Aston Global or an authorized reseller) that the Product manufactured by Aston Global is free from manufacturing defects in materials and workmanship, when used under normal conditions and when such Product has not been modified or changed in any manner after leaving Aston Global's warehouse or plant. If any Product manufactured by Aston Global is found to have manufacturing defects in materials or workmanship, such Product will be repaired or replaced by Aston Global. This warranty applies only against defects discovered within the warranty period and extends only to the original purchaser of the Product. Parts repaired or replaced under the terms of this Warranty will be warranted for the remainder of the original warranty period only.

Proof of purchase is required to exercise this Warranty. Aston Global may, at its option, examine and inspect the alleged defective Product, and Aston Global may request that parts be returned to Aston Global at Owner's expense for factory inspection. The determination as to whether Product shall be replaced, or in the alternative, repaired, shall be made solely by Aston Global. If a Product is determined to be covered by the above Warranty, Aston Global will ship the replacement part(s) to Customer by either ground shipping or US postal service. Increased costs for expedited delivery, if requested by Customer, are the responsibility of Customer. Parts not currently in stock may require up to a 6 week delivery time after placement of order.

The above warranty is subject to the following conditions: (1) the Product must be installed in a single family dwelling unit where the original purchaser of the Product resides; and (2) the Product must be maintained as described in the owner's manual supplied with the Product.

For glass and acrylic panels, the customer must (a) open and inspect the Product upon delivery (without releasing the delivery driver until visual verification that the Product arrived in a good and acceptable condition); and (b) clearly notate damage on the delivery acknowledgment receipt. Failure to do so, and any damage discovered to glass or acrylic panel after delivery, will be repaired or replaced at the sole discretion of Aston Global.

THIS WARRANTY DOES NOT COVER:

1. Product installed in buildings other than single family dwelling units.
2. Product installed outdoors or any other non-standard bathroom location.
3. Component parts not manufactured by Aston Global.
4. Workmanship of any installer of Aston Global Product. This warranty does not assume any liability of any nature for unsatisfactory performance caused by improper installation, or any damages to property resulting from improper installation or use of the Products, including but not limited to flooring, subfloor, tile, walls, sheet rock, concrete board, paint, plumbing fixtures and ceilings.
5. Labor costs incurred in the removal, disassembly, reassembly, or installation of the Product(s), including replacement Products issued under the Warranty, or costs for transportation to Aston Global, and any other materials necessary to return Product to Aston Global.
6. Any Product that has been damaged as a result of being improperly serviced or operated, including, but not limited to, the following: operated with insufficient water; allowed to freeze; subjected to flood conditions; operated with water conditions or additives which cause unusual deposits or corrosion in or on the Product, or subject to any other abuse or negligence.
7. Any Product that has been damaged as a result of natural disasters, including, but not limited to, lightning, fire, earthquake, hurricanes, tornadoes or floods.
8. Product used for any purpose other than residential bathroom usage.

LEGAL DISCLAIMERS

ALL IMPLIED WARRANTIES, INCLUDING WARRANTIES OF MERCHANTABILITY AND FITNESS FOR A PARTICULAR PURPOSE, ARE HEREBY DISCLAIMED IN THEIR ENTIRETY WITH RESPECT TO ALL PURCHASERS OR OWNERS. FAILURE TO RETURN THE WARRANTY CARD SHALL HAVE NO EFFECT ON THE DISCLAIMER OF THESE IMPLIED WARRANTIES. ALL EXPRESS WARRANTIES SHALL BE LIMITED TO THE DURATION OF THIS EXPRESS LIMITED WARRANTY AND EXCLUDE ANY LIABILITY FOR CONSEQUENTIAL OR INCIDENTAL DAMAGES RESULTING FROM THE BREACH OF ANY EXPRESS WARRANTY. Some states do not allow the exclusion or limitation of incidental or consequential damages, so the above limitations or exclusions may not apply. No dealer, distributor, service company or other party is authorized to change, modify or extend the terms of this warranty in any manner whatsoever.

Aston Global and its representatives shall not be liable for any injury, loss, cost or other damages, whether incidental or consequential, arising out of any defect covered by this Warranty including and without limitation, loss of use of the Product and cost for removal of defective Product, even if Aston Global has been advised of the possibility of such damage. The liability of Aston Global under this Warranty, if any, shall not exceed the original amount paid for the Product covered by the Warranty. Coverage under this Warranty shall commence as of the original date of purchase and the duration of such coverage shall not extend for any reason whatsoever beyond the stated time period. The Customer is required to provide adequate access to the Product for any repair or inspection. Aston Global shall not be liable for expenses or damage which may include but are limited to water damage, removal of any and all common building product such as tile, flooring, wood, sheet rock, plumbing fixtures, concrete board, vanities, bathtubs and toilets or any other custom items.

THIS WARRANTY GIVES YOU SPECIFIC LEGAL RIGHTS AND YOU MAY HAVE OTHER RIGHTS WHICH VARY FROM STATE TO STATE. ASTON GLOBAL'S FAILURE TO ENFORCE ANY TERMS OR CONDITIONS STATED HEREIN SHALL NOT BE CONSTRUED TO BE A WAIVER OF SUCH PROVISION.

For prompt service, notify the original installer who, in turn, will notify the Aston Global distributor who supplied the Product. If this does not result in prompt service, contact Aston Global, Inc. at the address below with details in support of the warranty claim. For any questions about coverage of this Warranty, contact Aston Global at the address below.

Aston Global offers free phone support for the life of the Product to the original Owner.

The Warranty applies only to Products manufactured on or after January 1, 2012.

This Warranty may not be combined with any other warranty offered by Aston Global.



Customer Service
877-424-9699

Aston Global Inc
1501 10th St Suite 150
PLANO, TX 75074

If further assistance is needed, or you
have a question, please visit our web
site at:

www.astonglobalinc.com