

LEUCOS®

INSTRUCTIONS FOR INSTALLATION - U.S.A. VERSION

SELIS S

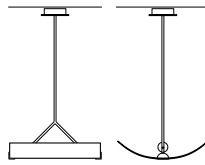

A1 Enclosed

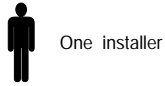

One installer







Save instructions

Revised
09 - SEP - 2003

WARNING: - DISCONNECT POWER BEFORE INSTALLATIONS.

- FIXTURE TO BE INSTALLED BY A CERTIFIED ELECTRICIAN.
- INSTALL IN ACCORDANCE WITH THE NATIONAL AND LOCAL ELECTRICAL CODES.
- FOLLOW DIRECTIONS CAREFULLY IN ORDER TO AVOID SCRATCHING OR DAMAGING THE GLASS DIFFUSER.

1. Screw plate "A" to the junction-box using holes "O" for that purpose. **FIG.1**
 2. Make the mains connections, connecting the wires to the terminal block.
 3. Place the mounting "B" over plate "A" and fix it in place using screws "P". **FIG. 1**
 4. Slacken off tie rod "Q" by approximately 5/8". **FIG.2**
 5. Fit the glass diffuser shade "C", placing it over the fixed clip "R" first and then over the other one twisting the lass slightly upwards. **FIG. 2**
 6. Tighten up the tie rod "Q" again, turning it by hand until it is firmly finger tight.
 7. Tighten the plastic grub screws "S" that hold the shade in place without overtightening them. **FIG.3**
 8. Install the light bulb .
Halogen version: Insert bulb inside double ended socket, then place the two half safety glass pyrex tubes "Y" in order to be coupled inside the opposite collars of rings "X" as shown. Clamp the two parts by pushing the two release springs "Z" as shown in **Fig.4**.
- NOTE:** IF THE LAMP CONTAINMENT BARRIER "Y" BREAKS, IT MUST BE REPLACED BEFORE USING THE LAMP AGAIN
9. Switch on the mains power.

- Fluorescent version: max 2x23W E26 type SLS 
- Incandescent version: max 2x100W E26 type A-19 
- Halogen version:  max 1x200W RSC type T3 

For additional information please contact your local dealer or
LEUCOS U.S.A. at: tel. (732) 225-0010 fax (732) 225-0250

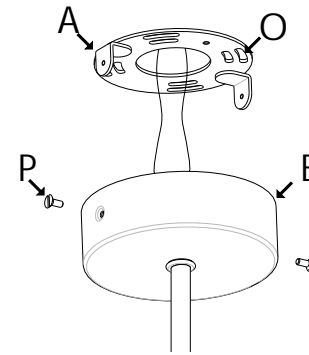

FIG.1

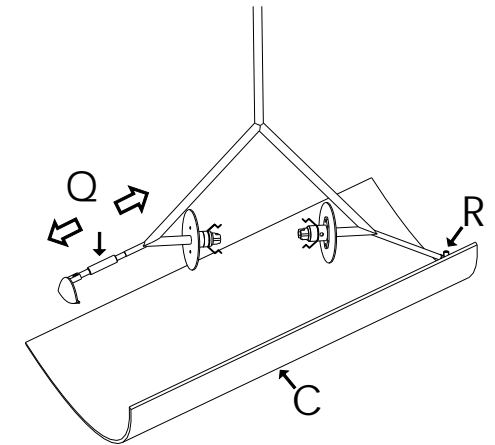

FIG.2

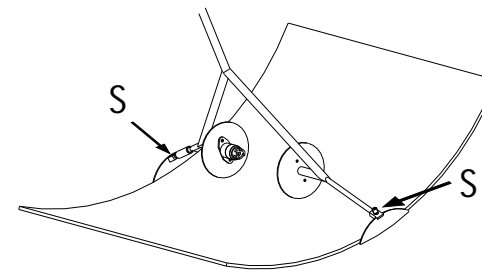

FIG.3

Halogen version:

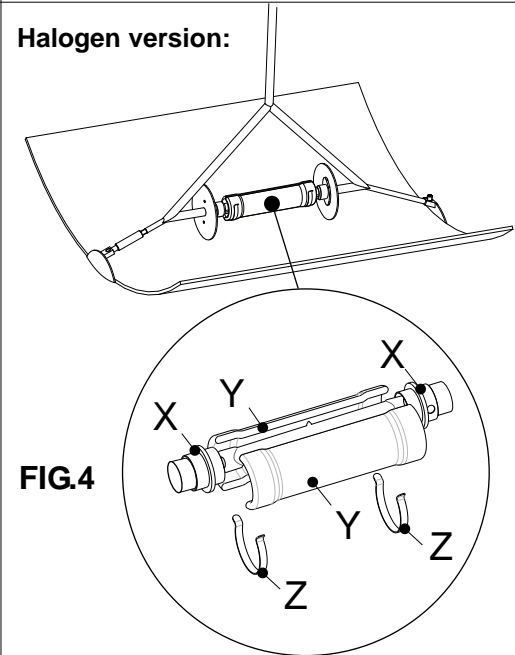

FIG.4

CIRCUIT DIAGRAM:

