

LEUCOS®

ISTRUZIONI DI MONTAGGIO E MANUTENZIONE
INSTALLATION INSTRUCTIONS

GOCCIA P 1- GOCCIA P 2

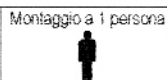
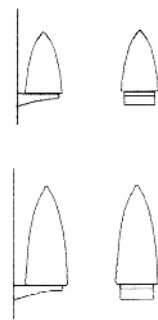

Indice di edizione
18/05/2005

NOTA : - Eseguire le operazioni con molta attenzione per non graffiare o scheggiare il vetro.
- Prima di eseguire ogni operazione assicurarsi di aver disinserito l'alimentazione.

1. Sfilare le due viti "C" dalla struttura in modo da separare la staffa "A" dal coperchio "B". Fig.1.
2. Fissare la staffa "A" a parete utilizzando i fori asolati "D" che permettono un eventuale regolamento della staffa in asse di fissaggio a muro. Fig.2.
3. Rivestire i cavi di rete con le guaine di protezione fornite in dotazione ed eseguire i collegamenti alla rete di alimentazione.
4. Inserire la lampadina. Infilare il collo del vetro attraverso il foro della montatura ed appoggiare il vetro alla stessa. Fig.3
5. Avvitare, moderatamente i perni "E" in modo equivalente imprigionando così il collo del vetro tra loro e la linguetta bloccavetro anteriore "F" vedi Fig.4.
6. Assemblare il coperchio "B" alla struttura con le due viti "C". Fig.5.
7. Riattivare l'alimentazione di rete.

IMPORTANTE : Date le caratteristiche della verniciatura, per la sua pulizia non usare prodotti contenenti alcool, solventi o ammoniaca, o sostanze abrasive. Utilizzare esclusivamente un panno morbido asciutto o umido d'acqua.

GOCCIA P 1 max. 1x100W KE27
GOCCIA P 2 max. 1x150W KE27

FIG. 1

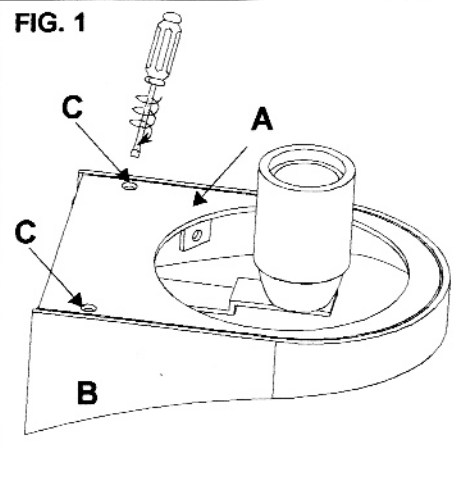

FIG. 2

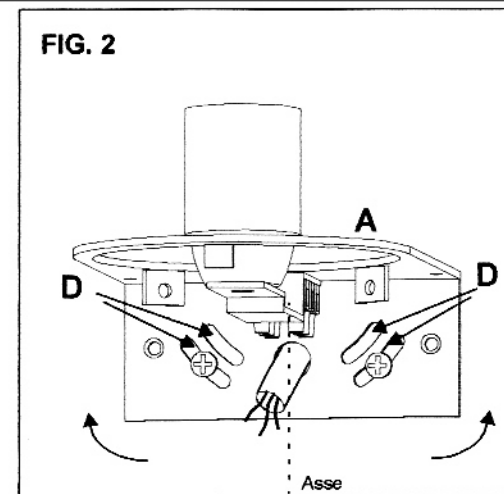

FIG. 3

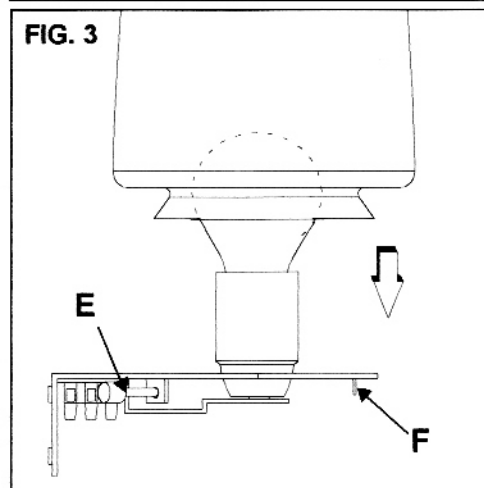

FIG. 5

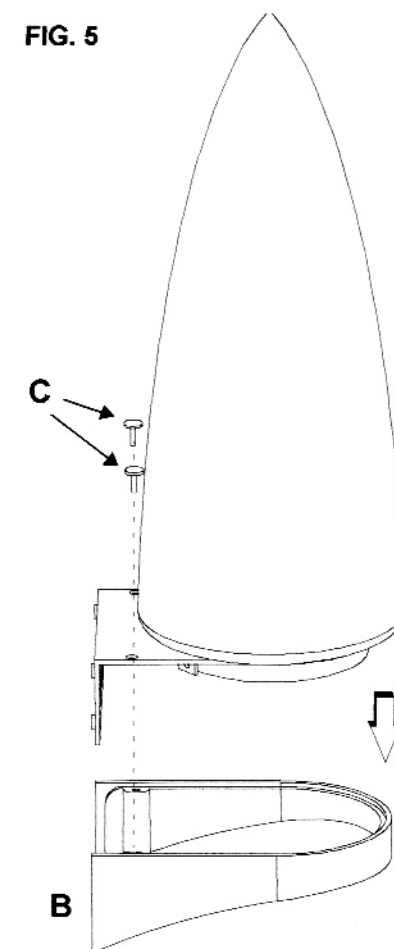
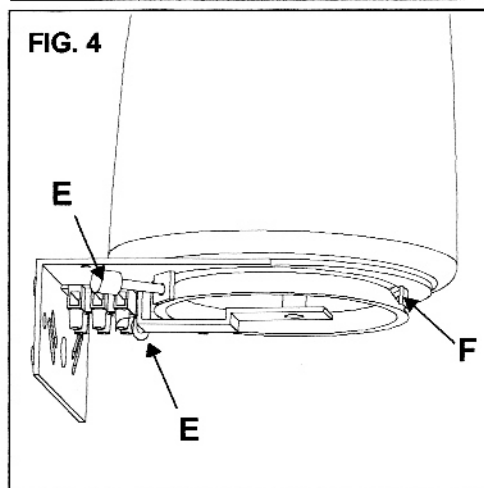

FIG. 4





DISCONNECT POWER BEFORE INSTALLATION.
INSTALL IN ACCORDANCE WITH THE NATIONAL AND LOCAL ELECTRICAL CODES. HANDLE GLASS SHADE CAREFULLY IN ORDER NOT TO SCRATCH IT.

1. Remove the two screws "C" from fixture body in order to separate the top part "A" from the bottom part "B". Fig. 1.
2. Attach plate "A" to J-box utilizing the two slots "D" which will allow for the adjustment of the backing.
3. Connect the fixture's electrical wires to the supply wires.
4. Install light bulb.
5. Position the glass diffuser over the structure. Fig. 3.
6. Center the glass diffuser over the fixture arm and secure glass with the set screws "E" by tightening very gently. Fig. 4.
7. Re-install the metal cover "B" over the structure with the two screws provided "C". Fig. 5.
8. Restore power.

PLEASE NOTE: Due to the characteristics of the type of finish of the fixture base, please do not use any cleaning products that contains alcohol, harsh substances or ammonia. Simply use a soft cloth slightly moist.

GOCCIA P 1 max. 1x100W KE27 (For USA 1x60W - E26 - Type A 15)
GOCCIA P 2 max. 1x150W KE27 (For USA 1x100W - E26 - Type A 19)



ATTENTION:

- Avant d'effectuer quelque opération que ce soit, s'assurer que le secteur primaire soit hors tension.
- Effectuer les opérations avec précaution pour ne pas rayer ou casser le verre.

1. Retirer les 2 vis "C" de la structure de façon à séparer la patère "A" du couvercle "B" (Fig. 1).
2. Fixer la patère "A" au mur utilisant les percements "D" permettant le réglage correct de l'applique (Fig. 2).
3. Passer les câbles d'alimentation dans les gaines de protection fournies et effectuer les connexions électriques.
4. Visser l'ampoule E27. Glisser le diffuseur au travers du trou de la patère (Fig. 3).
5. Visser modérément les molettes "E" de façon équilibrée pour bloquer ainsi le col du diffuseur contre la languette métallique "F" (Fig. 4).
6. Remettre le couvercle "B" sur la patère et le fixer avec les 2 vis "C" (Fig. 5).
7. Réactiver l'alimentation générale.

Important:

Nettoyage du diffuseur: ne pas utiliser de produit contenant de l'alcool, solvant ou amoniacque ni substances abrasives. Utiliser exclusivement un tissu sec ou légèrement humide.

FOR USA MARKET ONLY CIRCUIT DIAGRAM:

For additional information please contact your local dealer or **LEUCOS U.S.A.** at: Tel.(732) 225-0010-Fax.(732) 225-0250

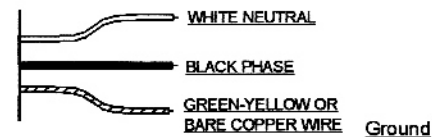
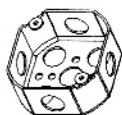

MOUNTS TO STANDARD JUNCTION BOX

