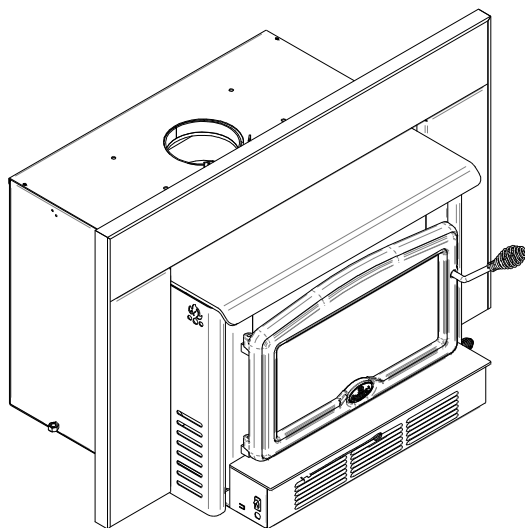




*Beyond fire...*

## OWNER`S MANUAL

### 2400 MODEL INSERT



US ENVIRONMENTAL PROTECTION  
AGENCY PHASE II CERTIFIED  
WOOD INSERT

Verified and tested following  
ULC S627 and UL 1482 Standards  
by:



Manufactured by : **STOVE BUILDER INTERNATIONAL INC..**  
250, rue de Copenhague, Saint-Augustin-de-Desmaures (Quebec) G3A 2H3  
**Tel.: 418 878-3040**  
**Fax: 418 878-3001**  
**[www.osburn-mfg.com](http://www.osburn-mfg.com)**



*This manual is available for free download on the manufacturer's web site. It is a copyrighted document. Re-sale is strictly prohibited. The manufacturer may update this manual from time to time and cannot be responsible for problems, injuries, or damages arising out of the use of information contained in any manual obtained from unauthorized sources.*

**READ AND KEEP THIS MANUAL FOR REFERENCE**

## INTRODUCTION

SBI INC., one of the most important wood stove and fireplace manufacturers in Canada, congratulates you on your purchase and wishes to help you get maximum satisfaction from your wood stove. In the pages that follow, we will give you advice on wood heating and controlled combustion as well as technical specifications regarding installation, operation and maintenance of the model you have chosen.

The instructions pertaining to the installation of your wood stove comply with ULC-S627 and UL-1482 standards.

**Read this entire manual before you install and use your new stove. If this stove is not properly installed, a house fire may result. To reduce the risk of fire, follow the installation instructions. Failure to follow instructions may result in property damage, bodily injury, or even death.**

**Consult your municipal building department or fire officials about restrictions and installations requirements in your area and the need to obtain a permit.**

**Keep this instructions manual for future references.**

### **CAUTIONS:**

- HOT WHILE IN OPERATION. KEEP CHILDREN, CLOTHING AND FURNITURE AWAY. CONTACT MAY CAUSE SKIN BURNS.
- DO NOT USE CHEMICALS OR FLUIDS TO IGNITE THE FIRE.
- DO NOT LEAVE THE STOVE UNATTENDED WHEN THE DOOR IS SLIGHTLY OPENED.
- DO NOT BURN WASTES, FLAMMABLE FLUID SUCH AS GASOLINE, NAPHTHA OR MOTOR OIL.
- DO NOT CONNECT TO ANY AIR DISTRIBUTION DUCT OR SYSTEM.
- ALWAYS CLOSE THE DOOR AFTER THE IGNITION.

*This heating unit must serve as a supplementary heat source. An alternative heat source should be available in the home if needed. The manufacturer cannot be responsible for additional heating costs associated with the use of an alternative heat source.*

*It is highly recommended that the user buys this product from a retailer who can provide installation and maintenance advices.*

### **REGISTER YOUR WARRANTY ONLINE**

To receive full warranty coverage, you will need to show evidence of the date you purchased your stove. Keep your sales invoice. We also recommend that you register your warranty online at

[www.osburn-mfg.com](http://www.osburn-mfg.com)

Registering your warranty online will help us track rapidly the information we need on your insert.

# **TABLE OF CONTENTS**

<b>1.0</b>	<b>PRE-INSTALLATION REQUIREMENTS.....</b>	<b>3</b>
1.1	MASONRY FIREPLACE REQUIREMENTS .....	3
1.2	VENTING REQUIREMENTS .....	4
1.3	DOOR OVERLAY INSTALLATION.....	5
<b>2.0</b>	<b>INSTALLATION.....</b>	<b>6</b>
2.1	SUITABLE FIREPLACE DIMENSIONS .....	7
2.2	OUTSIDE COMBUSTION AIR.....	7
2.2.1	HEARTH REQUIREMENTS.....	7
2.3	SAFETY INFORMATION .....	8
2.4	INSTALLATION INSTRUCTIONS .....	8
2.5	POSITIONING THE UNIT .....	9
2.6	FACEPLATE INSTALLATION.....	9
<b>3.0</b>	<b>OPERATION .....</b>	<b>14</b>
3.1	SAFETY INFORMATION .....	14
3.2	FUEL .....	15
3.2.1	SIMPLE WOOD MOISTURE TEST.....	16
3.3	NOTES ABOUT FIRST FIRING .....	16
3.4	LIGHTING A FIRE.....	16
3.5	MAINTAINING THE FIRE.....	17
3.6	FAN OPERATION.....	18
<b>4.0</b>	<b>MAINTENANCE.....</b>	<b>19</b>
4.1	CARE AND CLEANING.....	19
4.2	ASH REMOVAL.....	19
4.3	CHIMNEY CLEANING.....	19
4.5	SECONDARY AIR TUBE REPLACEMENT (SEE FIGURE 9).....	20
<b>5.0</b>	<b>TROUBLESHOOTING .....</b>	<b>21</b>
<b>6.0</b>	<b>SPECIFICATIONS.....</b>	<b>22</b>
	<b>OSBURN LIMITED LIFETIME WARRANTY .....</b>	<b>23</b>

# 1.0 PRE-INSTALLATION REQUIREMENTS

## 1.1 Masonry Fireplace Requirements

The masonry fireplace must meet the minimum code requirements, or NFPA 211 or the equivalent for a safe installation. Contact your local Building Inspector for requirements in your area. An inspection of the fireplace should include the following:

1. **CONDITION OF THE FIREPLACE AND CHIMNEY:**

Examine the masonry fireplace and chimney prior to installation, to determine that they are free from cracks, loose mortar, creosote deposits, blockage, or other signs of deterioration. If evidence of deterioration is noted, the fireplace or chimney should be upgraded prior to installation.

2. **CHIMNEY CAPS:**

Mesh type chimney caps must have provision for regular cleaning, or the mesh should be removed to eliminate the potential of plugging.

3. **LINER:**

The chimney must have an acceptable 6" (152 mm) stainless steel chimney liner installed.

**NOTE:** The 2400 Insert is not approved for use with a positive flue connector into a masonry flue.

4. **ADJACENT COMBUSTIBLES:**

The fireplace should be inspected to make sure that there is adequate clearance to combustibles, both exposed combustibles to the top, side, and front as well as concealed combustibles, in the chimney and mantel area. Your local inspector should have information on whether older fireplaces are of adequate construction.

5. **OPENING SIZE:**

Refer to "*Suitable Fireplace Dimensions*" (Sec. 2.2) for suitable size fireplace openings.

**NOTE:** A METAL TAG IS PROVIDED AND IS TO BE FASTENED TO THE BACK WALL OF THE FIREPLACE, IF THE FIREPLACE HAS BEEN MODIFIED TO ACCOMMODATE THE INSERT.

## **1.2 Venting Requirements**

The flue is a critical component to a satisfactory installation. Your insert will attain its best performance if installed with a flue that generates its own draft. The minimum venting requirement will be the installation of a flue connector from the insert into the first tile of the chimney (see Figure 2.3). If you are using a masonry chimney, it is important that it be built in compliance with the specifications of the National Building Code or other applicable standard having jurisdiction. It must be lined with fire clay bricks, metal or clay tiles sealed together with fire cement (round flues are the most efficient). Ideally, the interior diameter of the masonry chimney should be identical to the insert smoke exhaust. You may also run a stainless steel liner inside the masonry chimney. A continuous 6" (152mm) stainless steel liner from the top of the chimney to the insert's smoke exhaust (see Figure 2.2) is the optimum system and will provide the best performance, as well as compensate for poor draft situations caused by large cross-sectional chimneys. The insert will not work without a positive seal in the chimney.

Chimneys constructed outside of the home, on an exterior wall, should be avoided if possible, especially in colder climates. Outside chimneys may not draw as well and may downdraft due to the difficulty in heating them up to operating temperature. Cooler chimneys will result in increased creosoting, less draft, and poorer performance. Draft is proportional to overall chimney height as well as to stack temperature. Draft can be increased by increasing chimney height, and by reducing heat loss from the chimney through an insulated liner.

Ensure that all joints in the flue systems are tightly sealed, since any leaks will result in reduced performance as well as a possible safety hazard. Using a fire screen at the extremity of the chimney requires regular inspection in order to insure that it is not obstructed thus blocking the draught, and it should be cleaned when necessary.

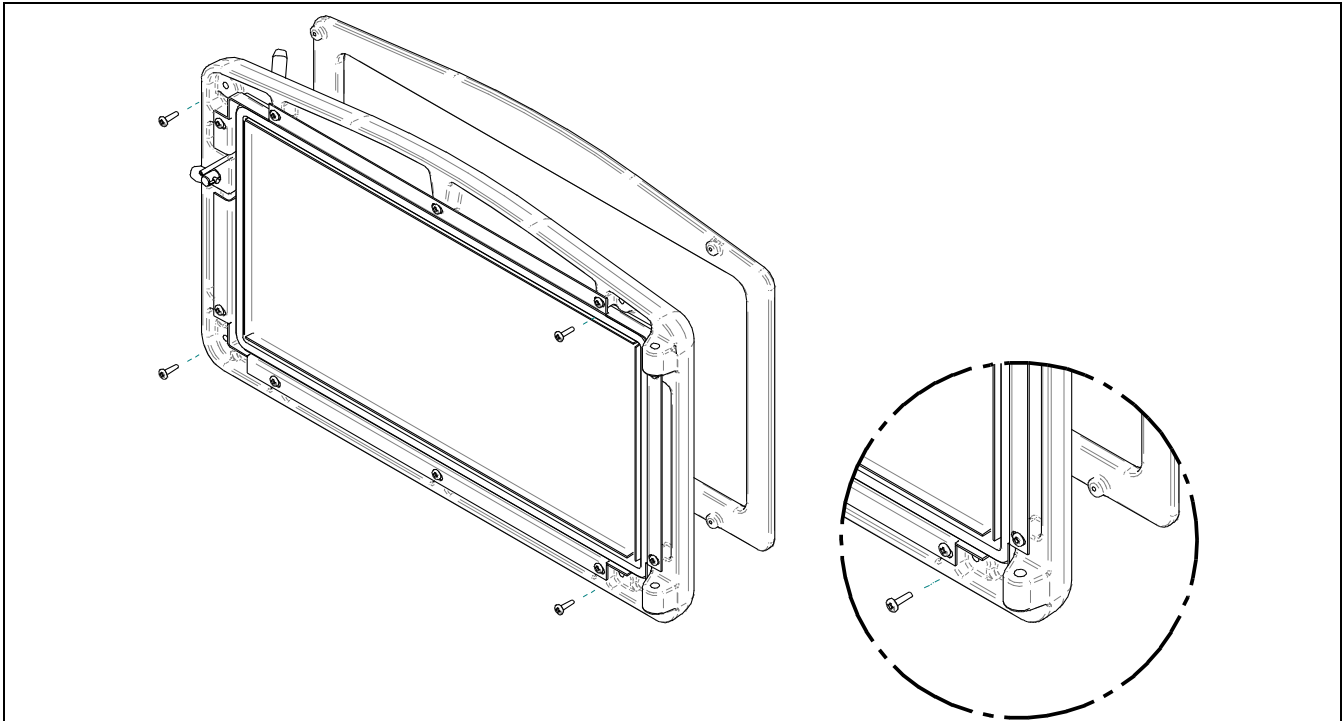
Do not connect this unit to a chimney flue serving another appliance.

This heating unit must serve as a supplementary heat source. An alternate heat source should be available in the home if needed. The manufacturer cannot be responsible for additional heating costs associated with the use of an alternative heat source.

It is recommended that the user buys this product from a retailer who can provide installation and maintenance advices.

### 1.3 Door overlay installation

In order to complete the assembly of your Osburn 2400 wood insert, you need to install the door overlay. See figure 1 below for installation instructions :



1- Position the overlay on the door frame and fix it in place from behind using the 4 screws.

**Note:** It is not necessary to remove the glass or any other component to install the overlay.

## 2.0 INSTALLATION

Clearances To Combustibles (Measured From Insert Body)

MEASURED FROM	WITHOUT MANTLE HEAT DEFLECTOR	WITH MANTLE HEAT DEFLECTOR
Side Wall (A)	14" (356mm)	14" (356mm)
Side Facing (B)	8" (203mm)	8" (203mm)
Top Facing (C)	20.5" (521mm)	13" (330mm)
Mantle (D)	25.5" (648mm)	16" (406mm)

Table 2.1

### CLEARANCES

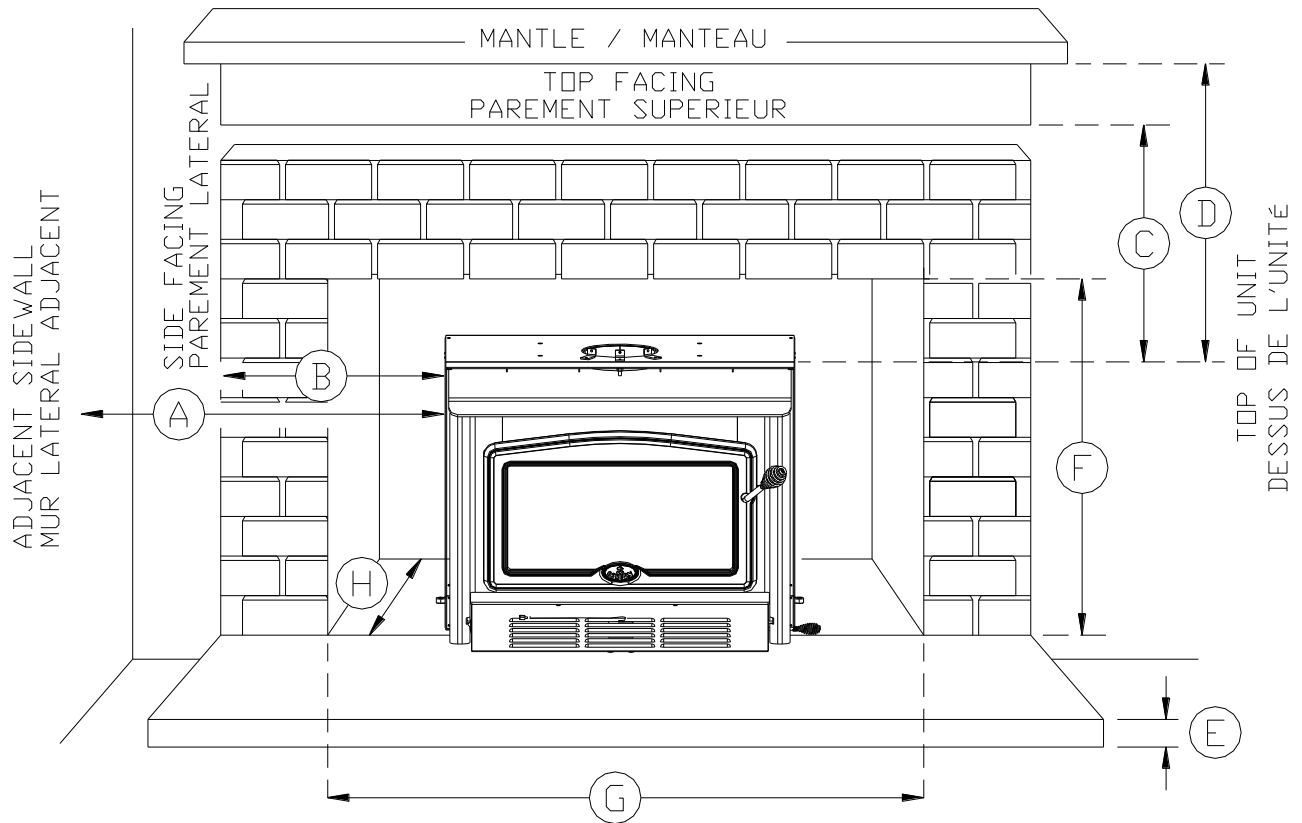


Figure 1

Note: If side facing protrudes more than 1.5" (38mm) in front of face of fireplace, then use sidewall clearance.

## 2.1 Suitable Fireplace Dimensions

MEASUREMENT FOR	MINIMUM	MAXIMUM STANDARD FACEPLATE	MAXIMUM LARGE FACEPLATE
Opening Height (F)	22.75" (578mm)	29" (737mm)	32" (813mm)
Opening Width (G)	32" (813mm)	44" (1118mm)	50" (1270mm)
Opening Depth (H)	16.25" (413mm)		

Table 2.2

## 2.2 Outside combustion air

Provision has been made on the 2400 Insert to accept fresh air for combustion purposes. A 4" (102mm) hole has been punched-out on the bottom air jacket, and the hole center line is located 11" (279mm) forward of the rear air jacket and 6" (152mm) in from the right hand air jacket.

### 2.2.1 Hearth Requirements

#### HEARTH EXTENSION:

Verify that there is a non-combustible hearth extending at least 16" (405 mm) in front of the fireplace and at least 8" (203 mm) to the side of the fireplace for a fireplace having an opening less than 6 ft<sup>2</sup> (0.55 m<sup>2</sup>); or a non-combustible hearth extending at least 20" (510 mm) in front and at least 12" (305 mm) to the sides for a fireplace having an opening of 6 ft<sup>2</sup> (0.55 m<sup>2</sup>) or **larger**. Fireplaces without this hearth extension will not meet the minimum requirements, and will require additional protection.



## 2.3 Safety Information

**NOTE:** This appliance is not recommended for use in a home if an occupant has any respiratory or any other related problems.

1. It is important to follow the installation and operation instructions. An improperly installed or operated insert could result in a safety hazard or fire, or damage to the unit, which would not be covered by the warranty. Contact local building or fire officials about restrictions and installation requirements in your area. You should be familiar with the installation and be sure that the work is done in accordance with this manual.

**WARNING:** DO NOT INSTALL THIS INSERT IN A SLEEPING ROOM.

2. Where lesser clearances are desired, consult your local authority as regulations may vary regarding the use of clearance reducing devices. Listed wall and floor shields are available to reduce clearances, and most building codes provide information on materials which may be used to reduce clearances (see Figure 1).
3. Maintain at least the minimum clearances to combustible material as specified in this manual. Clearances are measured to the nearest part of the insert (i.e. top edge on the side). Clearances to any combustibles, when measured directly out from the front, must be a minimum of 48" (1219mm).
4. Maintain at least the minimum floor protection for combustible floor materials as specified in this manual. Floor protection to the front is to be measured from the fuel loading door opening.
5. Osburn recommends that you install a listed smoke detector or alarm in your home. Normal operation of the insert will have no effect on the detector or alarm.
6. The insert is to be connected only to a lined masonry chimney and masonry fireplace conforming to building codes for use with solid fuel. Do not remove bricks or mortar from the existing fireplace when installing the insert.
7. Minimum chimney size is 6" (152mm) diameter. Maintain a 15' (4.5m) minimum overall height measured from the base of the appliance. Chimneys should be inspected to check for deterioration and to determine if they meet the minimum requirements, and be upgraded if necessary. The chimney must extend at least 3' (914mm) above the roof and at least 2' (610mm) above the highest point within an area of 10' (3m) of the chimney.
8. Do not use makeshift compromises during installation, as they could create a safety hazard and a fire could result.
9. **DO NOT CONNECT THIS APPLIANCE TO THE CHIMNEY OR FLUE SERVING ANOTHER APPLIANCE.**

## 2.4 Installation Instructions

Inspect the fireplace according to the safety information and fireplace requirements and have it cleaned and/or upgraded as necessary.

## 2.5 Positioning the unit

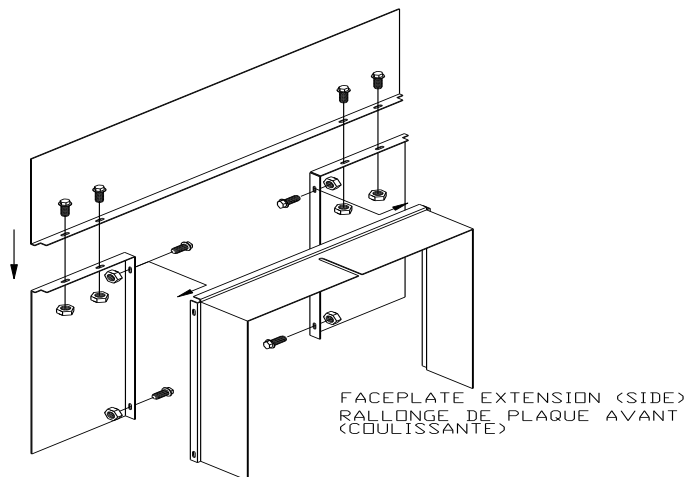
The more extended the insert, the greater the heat transfer to the room. When installed as an extended insert, the front edge of the air jacket will be installed flush with the fireplace facing. Otherwise the unit can be moved back as much as 3.5" (90 mm) or any position in between. The position chosen will depend on your own preference from most installations (where lintel is less than 6" (152 mm) and the depth is greater than 12.5" (320 mm)). See the table below.

MAXIMUM EXTENDED	I	J	L	M	N	O	P	AIR JACKET
INCHES	8 5/16	6 1/2	22 1/2	15 7/8	8 7/8	7	25	Flush with facing
MILLIMETRES	211	165	571	403	225	178	635	
MINIMUM EXTENDED	I	J	L	M	N	O	P	AIR JACKET
INCHES	11 7/8	10	23	19 1/2	5 1/4	3 7/16	21 7/16	Back from facing 3 3/8"
MILLIMETRES	302	254	584	495	133	87	545	

If lag-bolts and anchors are to be used to secure the insert, the hole locations should be marked with the unit in place. Remove the unit and locate the anchors.

## 2.6 Faceplate installation

1. Remove the faceplate panels from their box and assemble according to these faceplate instructions.
2. Remove the slide from within the air jacket.
3. Place the faceplate face down on a flat, nonabrasive surface (see Figure 3) so that the sides are a bit towards the middle.



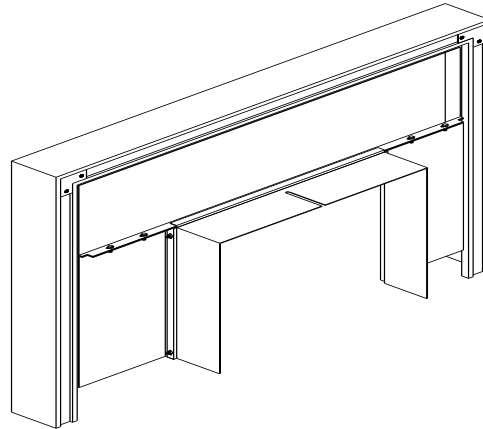
**Figure 3**

- Place the slide onto the faceplate so that the bends of the faceplate pieces go inside of the slide.

**2400 INSERT FACEPLATE BOLT ASSEMBLY:**

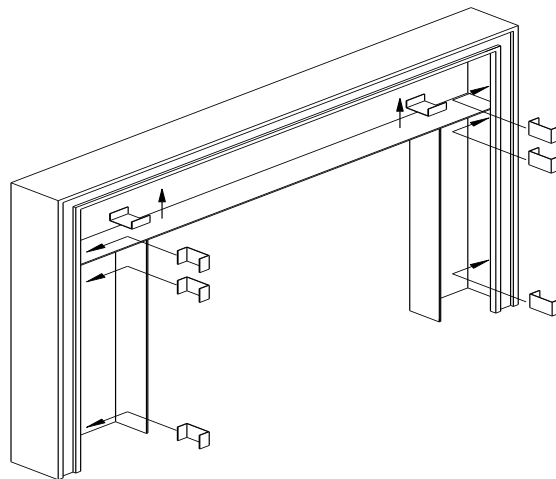
Contents: 8 - 1/4" x 1" (6.25 mm x 25 mm) carriage bolts  
8 - 1/4" (6.25 mm) flat washers  
8 - 1/4" (6.25 mm) hex nuts

- Line up the holes by pushing the sides out and install (smooth heads inside) all the bolts loosely. Line up the edge of the faceplate top and side, tighten the two bolts joining them, and then tighten the side bolts. Tighten the bolts on the other side in the same manner (see Figure 4).

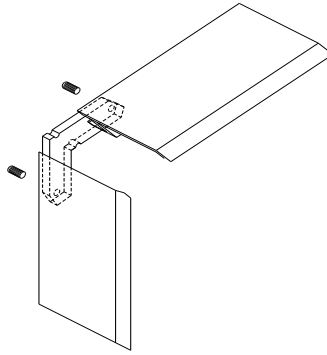


**Figure 4**

- Installation on Faceplates:  
Attach the mitered corners of the trim together using the corner brackets. Slide the assembled trim over the edge of the faceplate. See Figures 5 & 6.
- Attach the left and right side to the top with corner brackets supplied. Slip the trim over the faceplate and snap the eight trim retainers in place (see Figure 5).



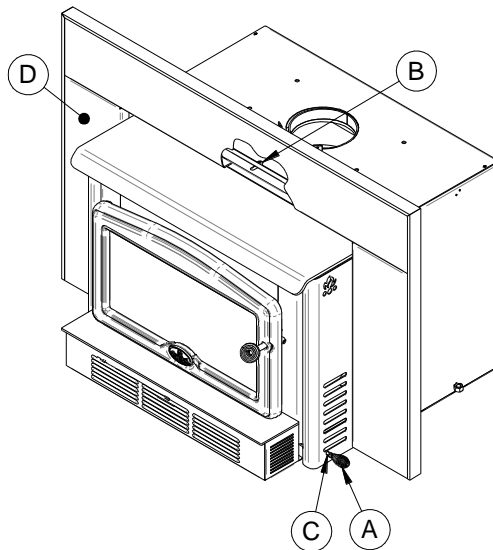
**Figure 5**



Back view of faceplate

**Figure 6**

8. Lift the insert into the fireplace. Square the insert to the face of the fireplace by adjusting the leveling legs on the sides at the rear of the insert. Check that the throat connector is in line.
9. If there is space to push the connector down from above, do so. Reach in through the insert and pull the throat connector down into place. If you are securing the connector to the flue collar with the screw, do that now.
10. Push the air control (A) in, all the way. Slide the adjustable faceplate sleeve back into its original location until the faceplate fits tightly against the fireplace facing. See Figure 7. One 7/16" (11mm) open end wrench should be used to turn the nut (B), located above the cook top in the centre, up so that it securely fastens the adjustable faceplate sleeve to the top air jacket. Take the air control slider spring handle (C) from the firebox and turn it onto the 1/4" diameter (6mm) air control rod (A).



**Figure 7**

Lift the insert into the fireplace. Square the insert to the face of the fireplace by adjusting the leveling legs on the sides at the rear of the insert. Check that the throat connector is in line.

If there is space to push the connector down from above, do so. Reach in through the insert and pull the throat connector down into place. If you are securing the connector to the flue collar with a screw, do that now.

## 2.7 Baffle & brick installation

**CAUTION:** Operation of your Osburn insert without the baffle may cause unsafe and hazardous temperature conditions and will void the warranty. **NOTE:** Before installing the firebrick, check to ensure that none are broken or damaged in any way. If so, have the damaged ones replaced. Check the firebrick for damage at least annually and replace any broken or damaged ones with new ones. Inspection and cleaning of the chimney is facilitated by the removable baffle.

The stove is shipped with all firebricks in place except for the top 3 at the rear of the firebox and the top sides (2 per side, 1 full and 1 partial). The balance of the loose bricks are for the baffle.

Install three top rear firebricks. The two full 9" (229 mm) bricks are on either side and are to be installed first. Then place the 7" (178 mm) brick in the center. Install the full 9" (229 mm) bricks on each side toward the rear of the firebox. After the 9" (229 mm) bricks are in place, install the partial 5 1/2" (140 mm) bricks on each side. The firebox bricking procedure will now be complete.

To install the baffle, follow the instructions on the next page. To remove, reverse the procedure:

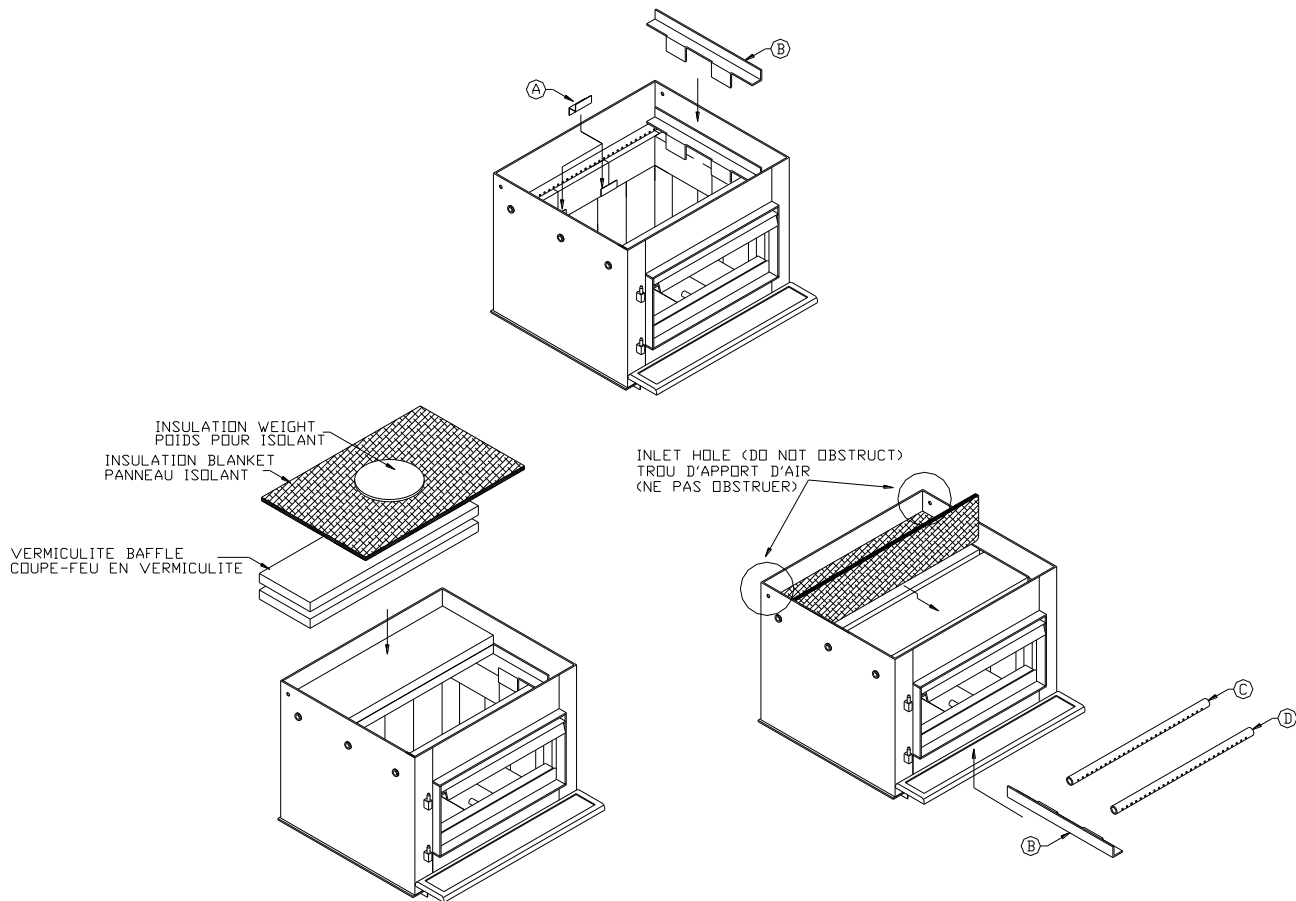


Figure 7

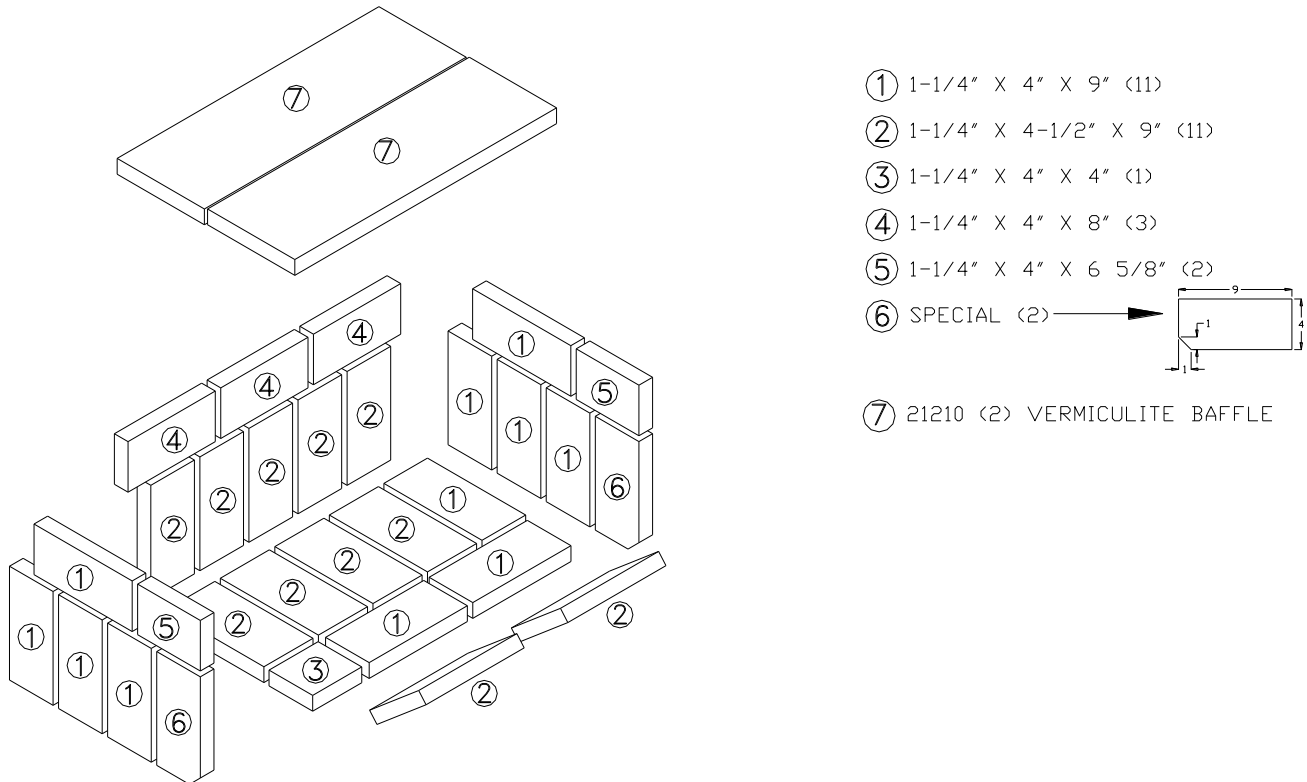
- 1- Install the stainless steel brick retainers (A) on the rear centre bricks intersections.
- 2- Install the first side baffle support (B) on one side of the firebox as shown in figure 7.
- 3- Put the vermiculite boards on top of the rear secondary air tube. The vermiculite boards must be placed next to each other (not stacked). Put the insulation blanket on top of the vermiculite

boards as shown in figure 7. Place the insulation weight at the top back center of the insulation blanket lined up with the flue outlet.

- 4- Install the second side baffle support (B) on the other side of the firebox.
- 5- Install the two remaining secondary air tubes and push the baffle assembly towards the back of the unit.

**NOTE:** As with all fibrous materials, avoid inhaling any airborne fibers.

Note : Make sure that rear inlet holes are not blocked by the insulation blanket.



**Figure 8**

## 3.0 OPERATION

### 3.1 Safety Information

1. This insert is designed for safe operation **WHEN BURNING CORDWOOD ONLY**. Altering or modifying the unit or the installation without proper authorization will void the certification, warranty, and safety listing, and may result in a safety hazard.
2. For safety reasons, never leave the unit unattended with the door open or ajar. An open door, and especially a door partially open or cracked, if left for longer than required for good ignition can potentially result in unsafe chimney temperatures, and if left unattended, hot embers or ignited fuel may fall out of the unit. Prolonged door open operation is not necessary provided the unit has been properly installed and dry kindling is used to start the fire.
3. Do not abuse the unit, either by over firing or by using wood or combustibles with salt content, or harmful chemicals. Misuse is not covered by warranty.
4. Even though your Osburn has been specifically designed and tested to prevent smoke spillage, always open the door slowly as this will minimize the likelihood of smoke spillage or a back draft causing flame or smoke to spill into the room.
5. Never use gasoline type lantern fuel, kerosene, solvents, charcoal lighter fluid, or inflammable liquids to start or "freshen" a fire in the insert. Keep all such liquids well away from the insert while it is in use.
6. All insert surfaces become very hot during operation. Care is needed, especially with children, to avoid contacting these surfaces.
7. Do not elevate the fire by means of grates, and irons or other means.
8. **Caution: Do Not Over Fire This Heater.** Do not burn fuel in the insert at a rate higher than that which will cause the ember bed level to exceed half the door opening height. If burning hot fires regularly, purchase an insert top thermometer, and do not exceed 840° F (450° C) as measured on the Cooktop. If the door handle of the insert becomes excessively hot to the touch, consider this to be an indication of over firing. Over firing can result in a safety hazard and can permanently damage the insert and chimney. This damage is not covered by the warranty.
9. Although the ceramic glass is extremely durable under any normal use, a few precautions are required. Do not attempt to push logs further into the fire by using the door, as the glass may break if it is heavily contacted by any solid object.

10. Never operate the insert with the door open, or cracked slightly open, except briefly during the lighting operation, and during refuelling. Leaving the door open continuously could seriously overheat the chimney and adjacent combustibles. Do not operate the insert if there is an abnormal air leakage into the unit, such as through deteriorated gaskets or cracked or broken glass. Do not operate the insert without a door gasket. Leakage can result in overheating, or in very airtight homes, could possibly cause smoke spillage into the room. Smoke may contain carbon monoxide, which is poisonous, and in sufficient quantities is a health hazard.
11. We recommend that you have a fresh air or make up air supply for the insert. In Canada this is a building code requirement. If this is not done, it could cause poor air quality in the home, poor and incomplete combustion, and poor efficiency in the insert.

### 3.2 **Fuel**

1. Fuel for the insert must not be stored closer than the required clearances to combustibles and not in the space required for ash removal.
2. Your Osburn insert is designed to burn **CORDWOOD FUEL ONLY**. Do not burn coal, charcoal, or trash in the unit. Highly flammable items such as trash may ignite creosote in the chimney, resulting in a chimney fire. Never burn salt wood, beachwood, chemically treated wood, or wood removed from salt water, since the deposits left will deteriorate the firebox. Damage caused by chemicals or salt is not covered under warranty.
3. Seasoned dense wood is recommended. Wood should be air dried in a covered ventilated area for six months to a year or more. This reduces the moisture content of the wood, resulting in better insert performance. Wood species with moisture content of 20% or less are ideal. Dry seasoned wood can be distinguished from green wood by the checks or cracks in the ends.
4. Wet or green wood will tend to cause the fire to smoulder, producing large amounts of creosote. Creosote build-up could result in a chimney fire. This wood will also prove difficult to keep burning properly, and fires will tend to go out. Green wood produces very little heat, and sometimes causes customers to think that the insert does not work. If you must burn wet wood, use only small amounts mixed with dry wood.
5. Decayed wood or low-density wood has very little energy content or heating value, and will not burn satisfactorily for long periods of time.

An example of the energy values of some common wood fuels is given in Table 3.1  
For recommended wood sizes, refer to the specifications.



## Common Heating Values of Cordwood

<b>Hardwoods</b>	<b>Million Btu/Cord</b>	<b>Softwoods</b>	<b>Million Btu/Cord</b>
Birch	23.6	Douglas Fir	20.6
White Oak	28.3	Hemlock	17.1
Alder	17.6	Jack Pine	18.4

**Table 3.1**

### **3.2.1 Simple Wood Moisture Test**

Add one large piece of wood to the top of an established fire. If it starts to burn on three sides within one minute, it is dry and seasoned and right for burning. If it turns black and starts to burn in three minutes, it is damp. If it turns black and does not start burning until after five minutes, it is green and wet. If it hisses at any time the wood is soaked and will not burn until excess moisture is boiled away.

### **3.3 Notes About First Firing**

Before firing ensure that the room is well ventilated. Curing the paint is recommended to preserve the best quality finish. Heating the insert too intensely on the first fire will dull and lighten the colour on overheated areas, and cause smoke and odour to be emitted into the room. To cure the paint, the first two fires should be burned for only about twenty minutes each.

Allow the insert to get warm only, but not hot, i.e. 250° F (120° C) as measured by an insert top thermometer, then allow the insert to cool down. Light a third fire and burn it for about forty minutes to 450° F (230° C) or less. Once again cool the insert to room temperature, then operate it according to the following instructions. This extra care will result in a more durable, and uniform finish.

### **3.4 Lighting a fire**

1. Place enough crumpled balls of newspaper or other paper into the insert to cover the Bottom of the firebox.
2. Place small dry kindling on the crumpled paper.
3. Place larger dry kindling on top of the small kindling.
4. Open the draft control fully to the right (located on the right side of the faceplate, Figure 3.1)
5. Light a fire at the bottom of the crumpled paper and close the door. If the fire tends to go out, momentarily hold the door slightly ajar to fan the fire. As soon as the fire catches hold, close the door.

6. Ideally the large kindling should be burned until a thick bed of red embers is obtained. At that point, add cordwood fuel and continue to operate the draft control wide open until the fire is well established. Once the firebox is hot, the draft control can be partially closed by moving the knob to the left to adjust the intensity of the fire.

Use Table 3.2 to adjust the draft control to the desired burn rate:

### Draft Settings

BURN RATE	DRAFT SETTINGS
Low & Medium Low	Gently push the draft control rod all the way in
Medium	Gently pull the draft control rod out to approx. 1/8"
Medium High	Gently pull the draft control rod out to approx. 1/2"
High	Gently pull the draft control rod all the way out

**Table 3.2**

Closing the draft control down too soon will lower combustion efficiency, and may result in creosote build-up in the chimney (which could lead to a future chimney fire).

**Caution: The Adjustment Range Should Not Be Altered For Increased Firing For Any Reason.**

### 3.5 Maintaining The Fire

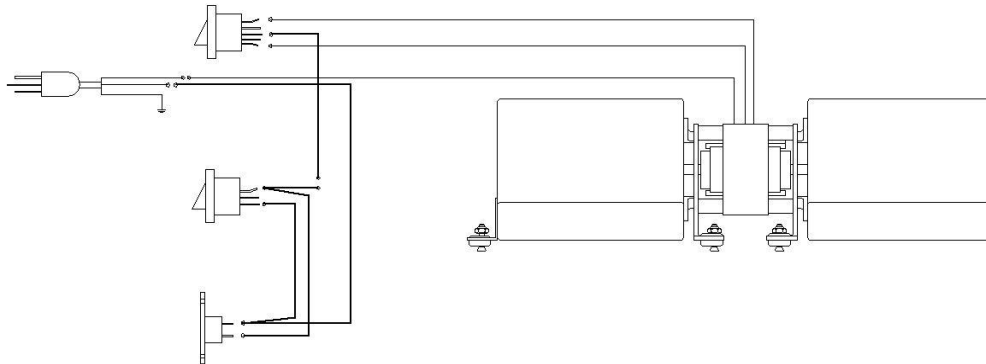
Your Osburn insert will work best if a thick bed of hot embers is maintained in the bottom of the firebox, and a minimum of two large pieces of seasoned fuel are added. Combustion efficiency is largely related to establishing a hot ember bed, and hot firebox temperatures. The quicker the insert and fuel get up to operating temperature, the better. A small intense fire is preferred to a large smouldering fire, both to improve combustion efficiency and to reduce the amount of creosote emitted. The best performance will be achieved by adding relatively small amounts of fuel to a well established ember bed, and then operating with the air inlet control open long enough to achieve a hot fire. Cordwood should be placed with air in between individual pieces. Use a poker to make an air channel in the embers below the wood, this will allow air to flow under the wood for a more efficient burn.

Extended burn times can be accomplished by first operating the insert on a full load with the air inlet controls wide open. Once the fire is well established, and the moisture has been driven out of the wood, reduce the air control to a lower setting. The unit should then burn cleanly without smoldering. If the fire smolders without flame, re-establish a hotter fire before moving the air control to the lower setting. A yellow flame burning in the top of the firebox is a good indication of a clean efficiently burning fire.

Refuelling technique is important for good performance. The best efficiency and performance from your insert can be achieved by adding partial loads of fuel and allowing them to get up to operating temperature before adding additional fuel. Adding a large amount of fuel at one time will increase the time required to get the fuel up to its ignition temperature, and an extended time to reach optimal performance. When refuelling, open the air control or hold the door partially open 1" (25 mm) or less, long enough (less than 5 minutes) so that the fire has well-established flames. When refuelling, care is required to ensure that fuel or embers do not fall out of the door opening.

### 3.6 Fan Operation

Allow the insert to heat up to operating temperature before turning on the fan. Increased airflow from the fan will remove heat and affect the combustion efficiency during start-up. For this reason we equipped the fan assembly with a heat sensor which will activate the blower at the selected speed. The 3 position rocker switch is to control the blower speed « Low towards the bottom – Off in the middle – Hi towards the top », « Low » being the minimum air flow, « Off » to stop air circulation and « Hi » being the maximum air flow. If you prefer to control the blower manually and at any time you will need to bypass the heat sensor. The heat sensor is bypassed when the 2 position rocker switch is set to OFF.



The fan should be kept clean and dust free. Life of the fan will be shortened if operated in a dust filled environment, or if the fan is overheated by restricting air supply. Stalling the motor, or over firing the insert with the fan turned off will also damage the fan. The fan must not be over heated.

## 4.0 MAINTENANCE

### 4.1 Care And Cleaning

Clean the insert frequently so that soot, ash and creosote do not accumulate. Do not attempt to clean the insert, glass or door when the unit is hot. Special care must be taken with Gold surfaces in order to maintain the finish at its original brilliance. Do not use an abrasive glass cleaner, which will scratch the glass or gold finish. Use only a soft clean damp cloth on the door, since some cleaners may remove the plating or paint.

#### 4.1.1 Glass Cleaning

Under normal operation the stove is designed to keep the glass clean. Glass cleaning may be required when burning damp wood and/or when burning slow fires. Generally if the glass is not staying clean then the unit is being under fired. Dirty glass may be self-cleaned by burning a hot fire (i.e. dry wood and opened draft controls) for a couple of hours. Good burning techniques will result in clean glass.

Hand clean the glass only when the fire is out and the insert is cold. A light film can usually be cleaned with paper towel and water. If heavy cleaning is required, a ceramic glass cleaner or polish is recommended, and should be rinsed off with water for best results.

### 4.2 Ash Removal

**CAUTION:** Ashes can start fires, even after several days of inactivity. Never dispose of ashes in a combustible container. Remove ashes only when the insert and ashes are cold.

Ashes should be removed from the insert frequently. When ashes are removed, they should be placed in a metal container with a tightly fitting lid. The closed container of ashes should be placed on a non-combustible floor or on the ground, well away from all combustible materials, pending final disposal. If the ashes are disposed of by burial in soil or otherwise locally dispersed, they should be retained in the closed container until all cinders have thoroughly cooled. Do not place other waste materials in the metal ash container.

### 4.3 Chimney Cleaning

Regular chimney maintenance, as well as good burning practices, are required to prevent chimney fires. The chimney and the chimney connector pipe must be maintained in good condition and be kept clean for optimal safety. The chimney should be checked regularly for creosote build-up. Inspection and cleaning of the chimney can be facilitated by removing the baffle.

**Caution: Operation Of Your Osburn 2400 Without The Baffle May Cause Unsafe And Hazardous Temperature Conditions And Will Void The Warranty.**

Contact your local, municipal, state, or provincial fire authority for information on how to handle a chimney fire before there is any chance that it may happen.

**Creosote – Formation And Need For Removal**

When wood (especially green wood) is burned without adequate heat or air supply, it produces tar and other organic vapours (*smoke*), which combine with expelled moisture to form creosote.

The creosote vapours condense in the relatively cool chimney flue of a slow-burning fire. As a result, creosote residue accumulates on the flue lining. When ignited, this creosote makes an extremely hot fire, which could be hazardous. Check frequently for creosote build-up. In the event of a insert or chimney component failure, replace only with equipment that is equivalent to the original, available from your Osburn dealer.

Your Osburn insert has been designed to reduce the amount of creosote produced. Even so, the chimney connector pipe and chimney should be inspected at least once every two months during the heating season to determine if a creosote build-up has occurred. If creosote has accumulated, it should be removed to reduce the risk of chimney fire. Call a professional chimney sweep, or go to your local Osburn dealer and purchase a chimney brush, and have the chimney cleaned.

**4.5 Secondary Air Tube Replacement (see Figure 9)**

1. Remove cotter pin at LH end of tube.
2. Slide tube to right and lower tube end below LH plenum.
3. Slide tube to left to remove.
4. Reassemble in reverse order using a new cotter pin. The cotter pin is a hammerlock style and locks into place by hitting the head sharply with a hammer.
5. Note that any tube can be replaced without disturbing the baffle.

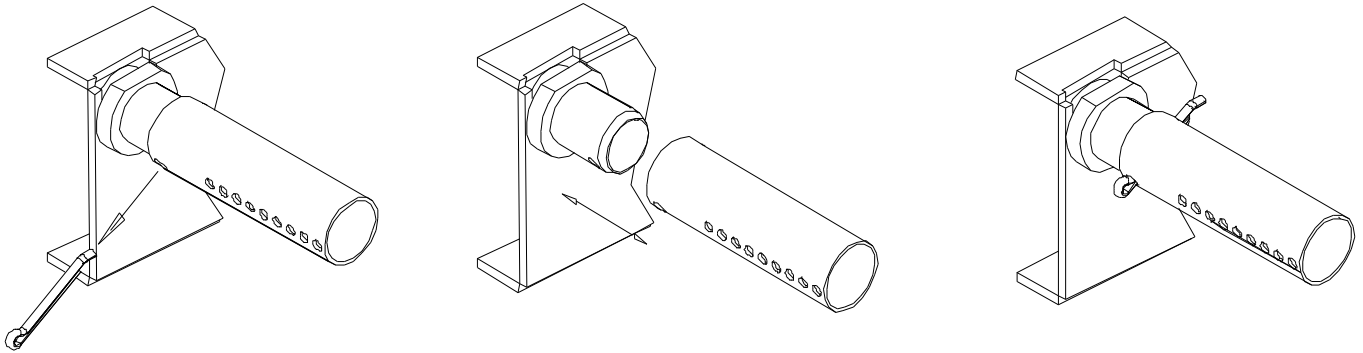
**Important Notes:**

The air tubes are identified for placement as follows:

Front to back: Tube No. 1 30 Holes of .188" diameter

Tube No. 2 32 Holes of .156" diameter

Tube No. 3 32 Holes of .156" diameter



**Figure 9 – Secondary Air Tube replacement**

## 5.0 TROUBLESHOOTING

Symptom	Possible Cause	Corrective Action
<b>I Smoke in room</b>	<ol style="list-style-type: none"> <li>1. Down draft</li> <li>2. Chimney blocked</li> <li>3. Chimney damper shut</li> <li>4. Baffle out of position</li> <li>5. New paint is curing</li> </ol>	<ol style="list-style-type: none"> <li>1. Upgrade chimney</li> <li>2. Clean chimney</li> <li>3. Open or remove damper</li> <li>4. Correctly position baffle</li> <li>5. Refer to instructions</li> </ol>
<b>II Wood burns poorly or is slow to start or no heat</b>	<ol style="list-style-type: none"> <li>1. Low draw</li> <li>2. Wet or decayed wood</li> <li>3. Blocked intake air</li> </ol>	<ol style="list-style-type: none"> <li>1. Upgrade chimney</li> <li>2. Use proper fuel</li> <li>3. Check intake air supply by removing fan from insert and opening a window</li> </ol>
<b>III Dirty glass</b>	<ol style="list-style-type: none"> <li>1. Insert is being under fired</li> </ol>	<ol style="list-style-type: none"> <li>1. Refer to instructions</li> </ol>
<b>IV Wood burns too fast</b>	<ol style="list-style-type: none"> <li>1. Too much draft in chimney</li> </ol>	<ol style="list-style-type: none"> <li>1. Contact a qualified technician</li> </ol>

## 6.0 SPECIFICATIONS

### TEST STANDARDS

ULC S627 (CSA B366.2) residential  
UL 1482 residential  
Oregon Department of Environmental Quality  
U.S. Environmental Protection Agency (Phase II, 1990)

Heating capacity\* – BTU/hr., EPA test wood : 40 938 BTU.

Heating capacity\* – BTU/hr., seasoned cordwood : 100 000 BTU/h.

Maximum recommended heating area : 500 to 2,700 square feet

Optimum efficiency : 78%

#### ***\*Why is the BTU indicated on the EPA label smaller than the one advertised?***

*You will notice a difference between the BTU output as indicated on the unit's white EPA label affixed to the glass and the BTU as advertised on our web site and/or product literature. The maximum BTU output we advertise for this unit is what will be obtained with a full load of seasoned cordwood inserted inside the firebox. The EPA output, on the other hand, is what has been obtained during emissions testing. The EPA test procedure requires that a special type of wood be used and positioned inside the firebox in a manner that does not represent the way the firebox volume would normally be utilized using seasoned cordwood. The EPA test load is typically much smaller. Hence, the BTU as per the EPA label is reduced. The BTU output that should be considered by a normal user is the one we advertise for seasoned cordwood.*

SHIPPING WEIGHT	545 lbs. (248 Kg)
COOK TOP HEIGHT	21 5/16" (541mm)
OVERALL HEIGHT	22 ½" (571mm)
OVERALL WIDTH	31" (787mm) with levelling nuts 29 ½" (749mm) without levelling nuts
OVERALL DEPTH	30" (762mm)
COOKTOP DEPTH INTO ROOM, EXTENDED	7 13/16" (198mm)
COOKTOP DEPTH INTO ROOM, FLUSH	4 1/4" (108mm)
MINIMUM NON-COMBUSTIBLE HEARTH SIZE	24" x 33" (610mm x 838mm)
FIREBOX SIZE	3.2 cubic feet
DOOR OPENING SIZE	8.25" x 19.5" (210mm x 495mm)
RECOMMENDED LOG SIZE	21" (533mm)
FLUE OUTLET	6" (152mm) diameter

## OSBURN LIMITED LIFETIME WARRANTY

The warranty of the manufacturer extends only to the original consumer purchaser and is not transferable. This warranty covers brand new products only, which have not been altered, modified nor repaired since shipment from factory. Proof of purchase (dated bill of sale), model name and serial number must be supplied when making any warranty claim to your OSBURN dealer.

**This warranty applies to normal residential use only. Damages caused by misuse, abuse, improper installation, lack of maintenance, over firing, negligence, accident during transportation, power failures, downdrafts, or venting problems are not covered by this warranty.**

This warranty does not cover any scratch, corrosion, warping, or discoloration caused by over firing, abrasives or chemical cleaners. Any defect or damage caused by the use of unauthorized parts or others than original parts void this warranty. An authorized qualified technician must perform the installation in accordance with the instructions supplied with this product and all local and national building codes. Any service call related to an improper installation is not covered by this warranty.

The manufacturer may require that defective products be returned or that digital pictures be provided to support the claim. Returned products are to be shipped prepaid to the manufacturer for investigation. If a product is found to be defective, the manufacturer will repair or replace such defect. Transportation fees to ship the product back to the purchaser will be paid by the manufacturer. Repair work covered by the warranty, executed at the purchaser's domicile by an authorized qualified technician requires the prior approval of the manufacturer. Labour cost and repair work to the account of the manufacturer are based on predetermined rate schedule and must not exceed the wholesale price of the replacement part. All parts and labour costs covered by this warranty are limited according to the table below.

The manufacturer at its discretion may decide to repair or replace any part or unit after inspection and investigation of the defect. The manufacturer may, at its discretion, fully discharge all obligations with respect to this warranty by refunding the wholesale price of any warranted but defective parts. The manufacturer shall in no event be responsible for any special, indirect, consequential damages of any nature, which are in excess of the original purchase price of the product. A one-time replacement limit applies to all parts benefiting from a lifetime coverage. This warranty applies to products purchased after March 1<sup>st</sup>, 2009.

DESCRIPTION	WARRANTY APPLICATION	
	PARTS	LABOUR
Combustion chamber (welds only), castings, convector air-mate, ceramic glass (thermal breakage only*), and secondary air tubes*.	Lifetime	5 years
Plating* (defective manufacture) – subject to limitations above.	Lifetime	n/a
Stainless steel firebox components, surrounds and heat shields, ash drawer, steel legs, pedestal, trims (aluminum extrusions), C-Cast baffle*, and vermiculite baffle*.	7 years	5 years
Carbon steel firebox components, glass retainers, and handle assembly.	5 years	3 years
Blowers, heat sensors, switches, rheostat, wiring, and other controls.	2 years	1 year
Paint (peeling), gaskets, insulation, firebrick, and ceramic fibre blankets.	1 year	n/a

*\*Pictures required*

Shall your unit or a components be defective, contact immediately your **OSBURN** dealer. Prior to your call make sure you have the following information necessary to your warranty claim treatment:

- Your name, address and telephone number;
- Bill of sale and dealer's name;
- Serial number and model name as indicated on the nameplate fixed to the back of your unit;
- Nature of the defect and any relevant information.

**Before shipping your unit or defective component to our plant, you must obtain from your OSBURN dealer an Authorization Number. Any merchandise shipped to our plant without authorization will be refused automatically and returned to sender.**