

Tools Required:

- 17mm socket
- 17mm wrench

Fasten the side frames to the cross braces as shown, starting with the floor cross brace. Do not fully tighten the bolts until all the bolts are in place. A flat washer should be on each side of the connection.

The Half Rack must be anchored to the floor for safety. Anchoring hardware is not included.

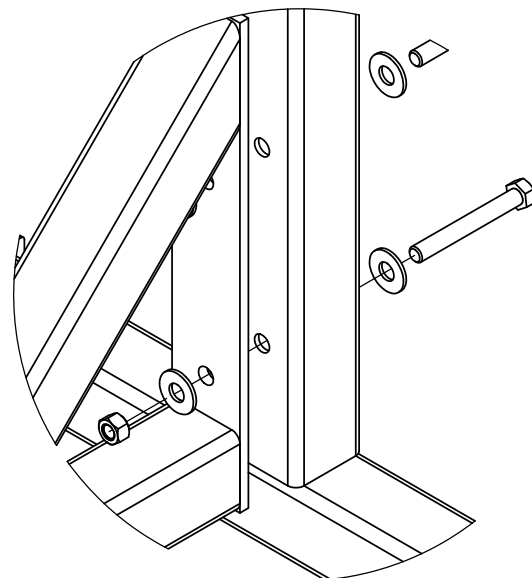

THIS WARNING IS GIVEN IN COMPLIANCE
WITH CALIFORNIA PROPOSITION 65:

WARNING

This product contains chemicals known to the
State of California to cause cancer, birth defects
or other reproductive harm.