



# Metal Print Rack Assembly Instructions

For model  
MPR10

**Tools Required:** Wrench (included)

## Parts Included:

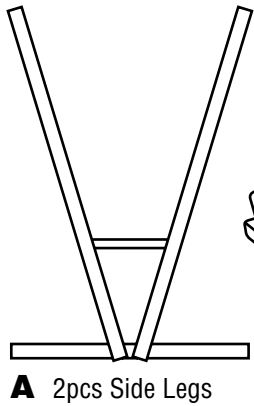

**A** 2pcs Side Legs

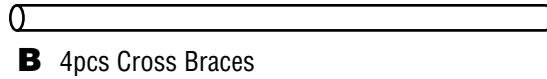

**B** 4pcs Cross Braces

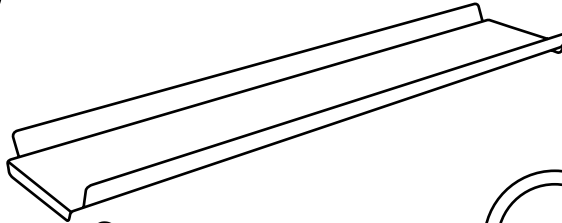

**C** 1pc Bottom Tray

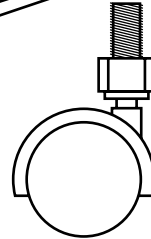

**D** 4pcs Casters

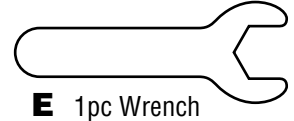

**E** 1pc Wrench

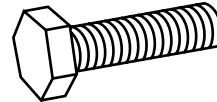

**F** 8pcs Bolts

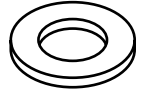

**G** 16pcs Washers

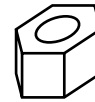

**H** 4pcs Nut  
(attached to  
caster bolt)

## To Assemble:

**1** Attach four Cross Braces (**B**) to two Side Legs (**A**) using eight Bolts (**F**) and 16 Washers (**G**) as shown in *Figure 1*. Horizontal caster mount should be positioned toward the outside of the rack. Tighten bolts using supplied Wrench (**E**).

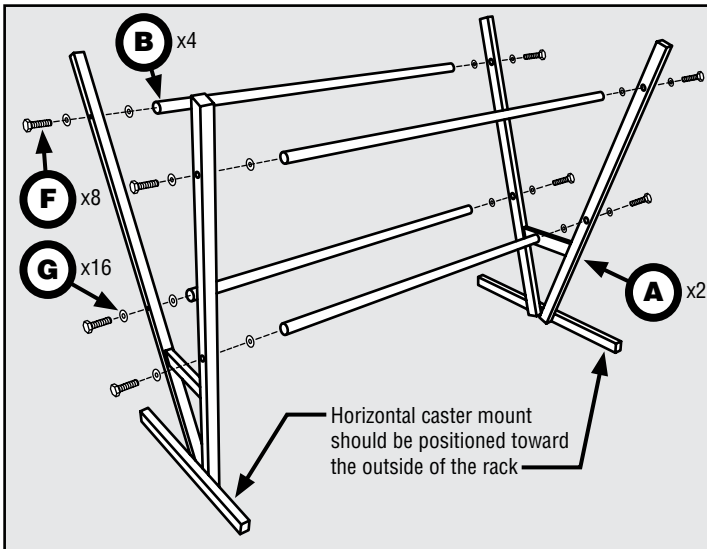

*Figure 1*

**2** Thread four Casters (**D**) into underside of Side Legs as shown in *Figure 2*.

**Note:** Caster height can be adjusted to level the rack on uneven surfaces. Adjust the caster height as needed by screwing the caster in or out, and then tighten the Nut (**H**) against the Side Leg using supplied wrench (**E**).

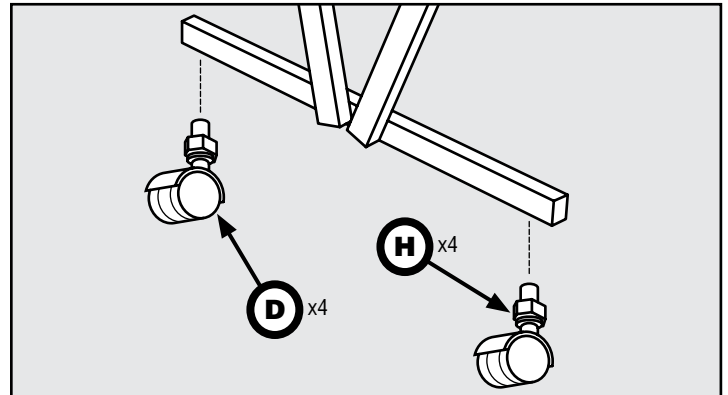

*Figure 2*

**3** Lay Bottom Tray (**C**) onto leg crosspieces as shown in *Figure 3*.

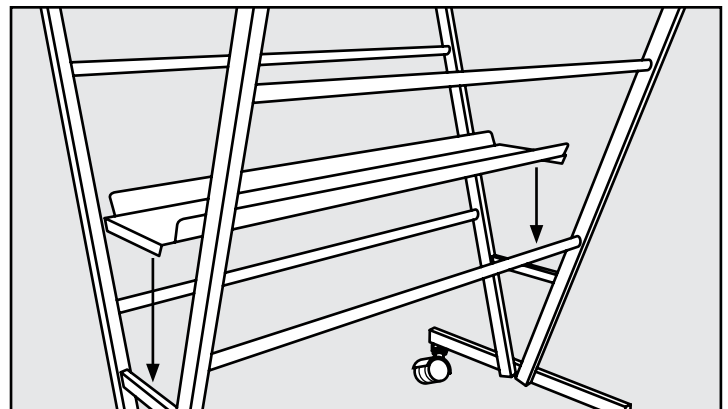

*Figure 3*