

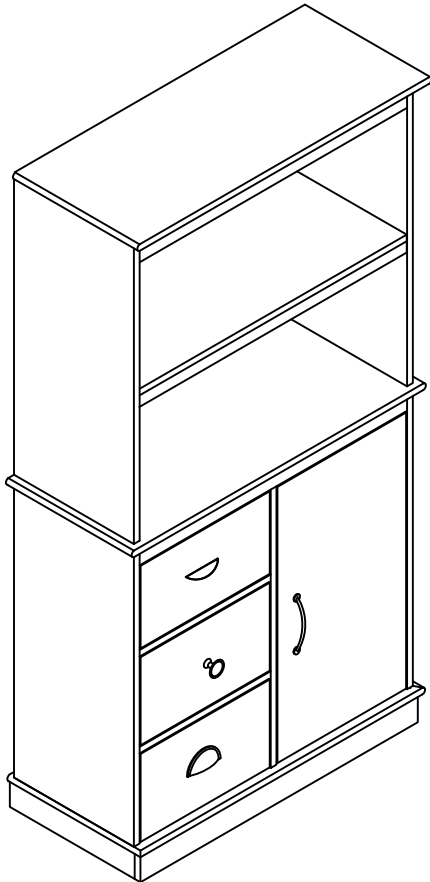

# 9634096



THIS INSTRUCTION BOOKLET CONTAINS IMPORTANT SAFETY INFORMATION. PLEASE READ AND KEEP FOR FUTURE REFERENCE.

ESTE FOLLETO DE INSTRUCCION CONTIENE INFORMACION IMPORTANTE DE SEGURIDAD. POR FAVOR, LEALA Y GUARDELA PARA PODER USARLA EN UN FUTURO.

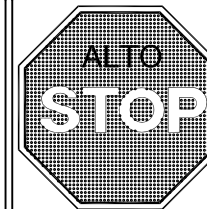

**DO NOT RETURN PRODUCT TO THE STORE**  
Individual stores do not stock parts.

**NO DEVUELVA ESTE PRODUCTO A LA TIENDA**  
Las tiendas no almacenan partes.

Lot Number / N<sup>o</sup>mero de Lote: \_\_\_\_\_

Date Of Purchase / Fecha de Compra: \_\_\_/\_\_\_/\_\_\_

If a part is missing or damaged, call our toll-free customer service line. We will gladly ship your replacement parts FREE of charge.

Si faltan partes o piezas, o éstas están dañadas, llame gratis al teléfono de servicio al cliente. Con gusto le enviaremos las partes sin cargo alguno.

Need Parts or Assistance?  
Necesitas partes o asistencia?

**1-800-489-3351**

or access our website  
to visite nuestra página de internet

[www.altrafurniture.com](http://www.altrafurniture.com)

For prompt, reliable service please have your assembly manual ready.  
Para obtener un servicio rápido y confiable, por favor guarde este manual para tenerlo siempre a mano.

Recommended # of people needed for assembly: 2

El número recomendado de personas necesarias para el montaje: 2

B34963409600

Thank you for purchasing from Altra Furniture.  
Visit [www.altrafurniture.com](http://www.altrafurniture.com) to view the limited warranty valid in the U.S. and Canada.

### ALTRA FURNITURE CUSTOMER SERVICE

Gracias por haber comprado de Altra Furniture.  
Visitar [www.altrafurniture.com](http://www.altrafurniture.com) para mirar la garantía limitada válida solamente en U.S.A y Canada.

### SERVICIO A LA CLIENTE DE ALTRA FURNITURE

#### Before starting - Antes de empezar.

- Read each step carefully before starting. It is very important that each step of instruction is performed in the correct order. If these steps are not followed in sequence, assembly difficulties will occur.  
Leer con cuidado cada paso antes de empezar. Es muy importante de ejecutar cada paso en el orden correcto. Si los pasos no están ejecutados en secuencia, ocurrirá dificultades en el montaje.
- Make sure all parts are included. Most board parts are labeled or stamped on the raw edge. Asegurar que todas las piezas son incluidas. La mayoría de las tablas tienen las etiquetas o los sellos en el lado sin acabado.
- Work in spacious area, preferably on a carpet, near the place the unit will be used. Trabajar en una área espaciosa, preferible sobre alfombra, cercas del lugar donde se va a usar el mueble.
- Have the following tools close at hand. Tener las herramientas siguientes cerca de la mano.
- Do not use power tools to assemble your furniture. Power tools may strip or damage the parts. No use herramienta eléctrica para montar su unidad. Las herramientas eléctricas pueden dañar las piezas.

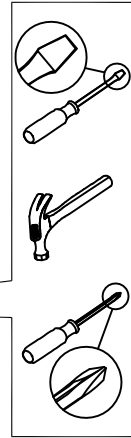

Call us at: 1-800-489-3351  
Llamar a: (in U.S.A. only) (Solo en U.S.A)



Fax: 1-636-745-1005  
Fax:



Visit our Website: [www.altrafurniture.com](http://www.altrafurniture.com)  
Visitar nuestro website:



Write to: ALTRA FURNITURE  
Escribir a: 410 East 1st Street South Wright City, MO 63390 USA  
Attn: Service Dept.

9:00am - 5:00pm  
Monday - Friday ~~9:00am - 5:00pm~~  
Central Time ~~Central Time~~  
Saturday ~~9:00am - 5:00pm~~  
Central Time ~~Central Time~~  
Lunes - Viernes ~~9:00am - 5:00pm~~  
Tiempo Central ~~Central Time~~  
Sábado ~~9:00am - 5:00pm~~  
Tiempo Central ~~Central Time~~

#### HELPFUL HINTS

- Visit our website for assembly video clips.
- Identify, sort and count the parts before attempting assembly.
- Call our toll free number if you need assistance identifying parts.
- Compression dowels are tapped in with a hammer.
- Slides have lips only on the right side.
- Cam locks that are properly fastened on a horizontal board will face toward the center of the unit, on a vertical board the point on the lock will face the bottom.
- Back panels provide stability and support. Use all the nails provided.
- When tapping nails into a board, be sure there are equal margins on all sides to square the unit.
- Units without the back panel installed may collapse.
- Clean the product with your favorite furniture polish and a soft cloth. DO NOT USE harsh chemicals or abrasive cleaners.
- Move your new furniture carefully, with two people lift and carry the unit to its new location.
- Never push, drag or scoot your furniture (especially on carpet).
- Your furniture can be disassembled and reassembled to move.
- Additional parts are available for a nominal fee.

#### NOTES UTILES

- Visitar nuestro website para mirar los videos cortos del montaje.
- Identificar, clasificar y contar las piezas antes de intentar el montaje.
- Llamar gratis a nuestro número de servicio si necesita ayuda con identificar las piezas.
- Las clavijas de compresión se taladran con un martillo.
- Las correderas sólo tienen las proyecciones en el lado derecho.
- Las cerraduras de leva que se atan propiamente en una tabla horizontal se puntan al centro de la unidad, y las en una tabla vertical se puntan al fondo.
- Los paneles traseros se mantienen la estabilidad. Usar todos los tornillos proporcionados.
- A taladrar los tornillos en una tabla, asegurarse que hay márgenes iguales en todos los lados para cuadrar la unidad.
- Las unidades sin panel trasero pueden derrumbarse.
- Limpiar la unidad con su pulimento favorito de mueble y una tela suave. NO UTILIZAR productos con químicos duros o abrasivos.
- Mover su mueble nuevo cuidadosamente, con dos personas levantar la unidad a su nuevo lugar.
- Nunca empujar o arrastrar su mueble (especialmente en alfombra).
- Poderse desmontar y volver a montar su mueble de para mover.
- Piezas adicionales están disponibles para una cuota nominal.

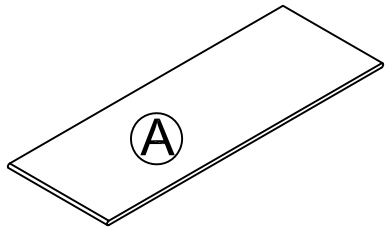

Hutch top shelf  
Estante superior para aparador  
T9634096010

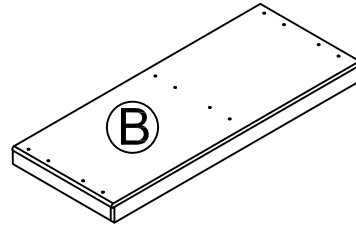

Bottom panel  
Panel del  
T9634096020

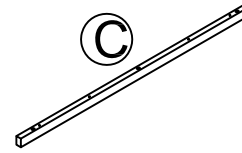

Shelf apron (2)  
Embellecedor de estante (2)  
T9634096030

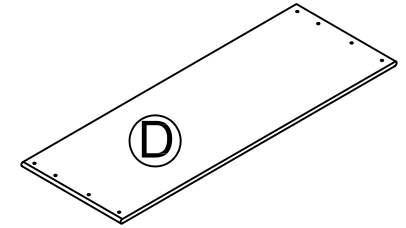

Top shelf  
Estante superior  
T9634096040

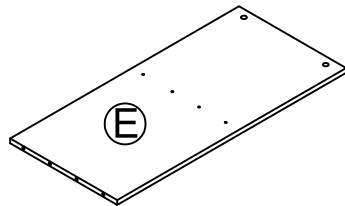

Hutch left side panel  
Panel Izquierdo para aparador  
T9634096050

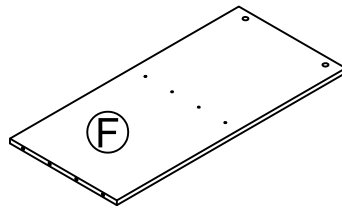

Hutch right side panel  
Panel derecho para aparador  
T9634096060

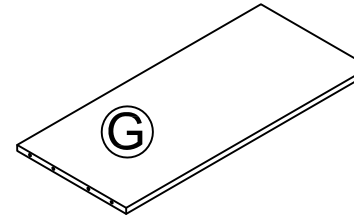

Hutch fixed shelf  
Estante fijo para aparador  
T9634096070

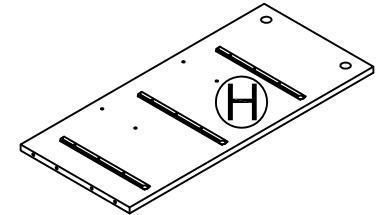

Left side panel  
Panel izquierdo  
T9634096080

Pre-assembled part / Partes premontados  
Left cabinet member/Corredera de mueble Izquierda (3) TWQ0050  
Screw / Tornillo (9) TWQ0051

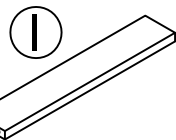

Support panel(2)  
Panel de Soporte (2)  
T9634096090

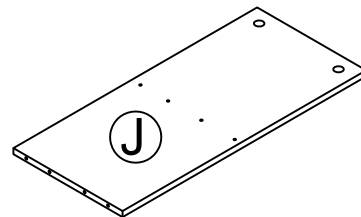

Right side panel  
Panel derecho  
T9634096100

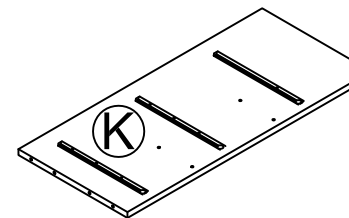

Pre-assembled part / Partes premontados  
Right cabinet member/Corredera de mueble derecha (9) TWQ0052  
Screw / Tornillo (9) TWQ0051

Partition panel  
Panel de partición  
T9634096110

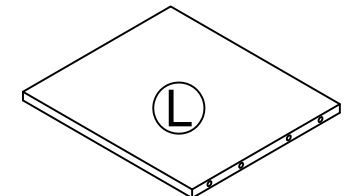

Fixed shelf  
Tablero fija  
T9634096120

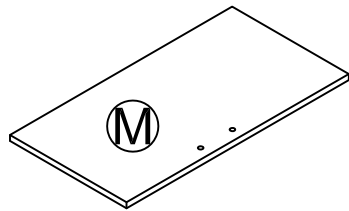

Door  
Puerta  
T9634096130

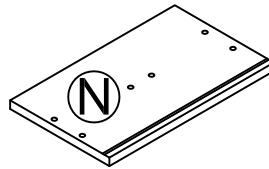

Upper drawer front  
Panel frontal del cajón superior  
T9634096140

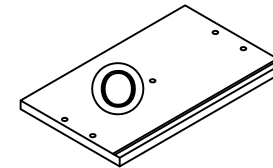

Middle drawer front  
Panel frontal del cajón central  
T9634096150

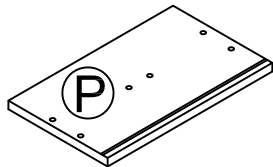

Lower drawer front  
Panel frontal del cajón inferior  
T9634096160

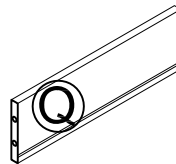

Pre-assembled parts / Parte premontados	
Left drawer runner/Deslizador izquierdo de cajón	TWQ0053
Screw / Tornillo (3)	TWQ0051

Left drawer side (3)  
Panel Izquierdo de Cajón (3)  
T9634096170

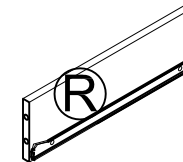

Pre-assembled part / Partes premontados	
Right drawer runner/Deslizador derecha de cajón	TWQ0054
Screw / Tornillo (3)	TWQ0051

Right drawer side (3)  
Panel Derecho de Cajón (3)  
T9634096180

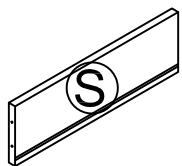

Drawer back (3)  
Trasero del cajón (3)  
T9634096190

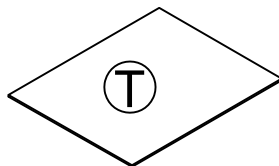

Drawer bottom (3)  
Fondo del cajón (3)  
T9634096200

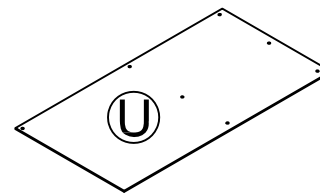

Back panel (2)  
Panel trasero (2)  
T9634096210

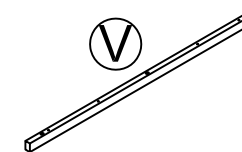

Shelf apron  
Embellecedor de estante  
T9634096220

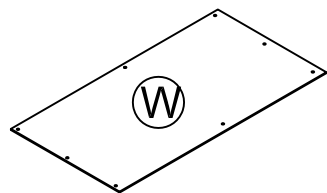

Back panel (2)  
Panel trasero (2)  
T9634096230

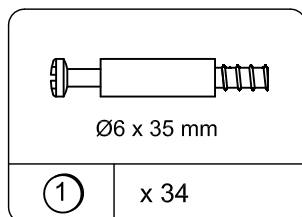

Cam bolt  
Perno de la leva  
TWQ0011

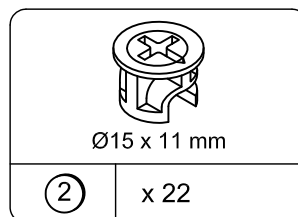

Cam lock  
Cerradura de la leva  
TWQ0012

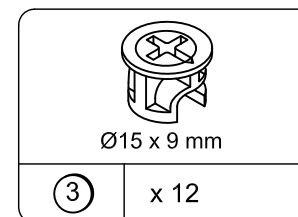

Cam lock  
Cerradura de la leva  
TWQ0070

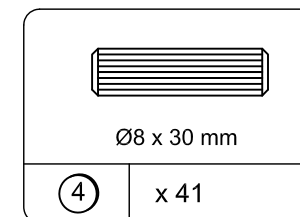

Wooden dowel  
Clavija de madera  
TWQ0003

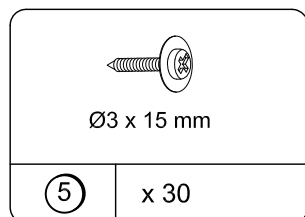

Screw  
Tornillo  
TWQ0009

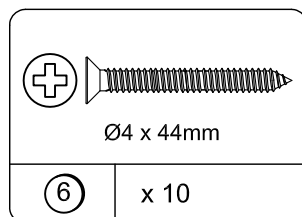

Screw  
Tornillo  
TWQ0027

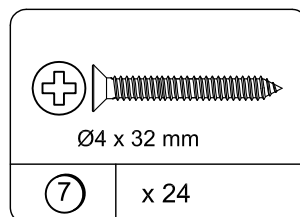

Screw  
Tornillo  
TWQ0010

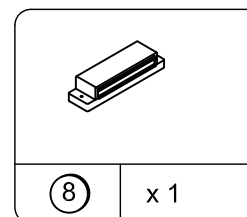

Magic catch  
Pestillo mágico  
TWQ0035

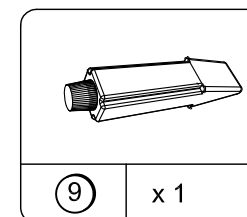

Glue  
Pegamento  
TWQ0008

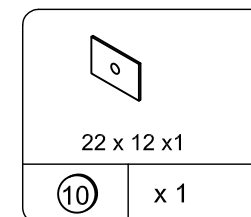

Magic catch plate  
Placa de pestillo mágico  
TWQ0036

# PARTS -PIEZAS

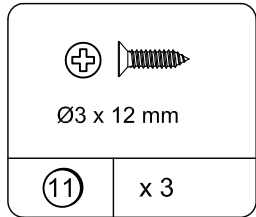

Screw  
Tornillo  
TWQ0037

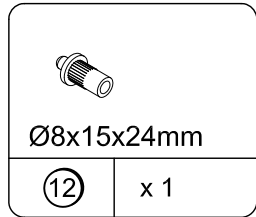

Door shaft  
Eje de puerta  
TWQ0038

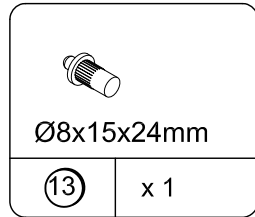

Door shaft  
Eje de puerta  
TWQ0039

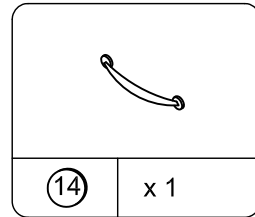

Handle  
Manija  
TWQ0042

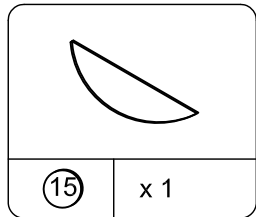

Pull  
Jalón  
TWQ0031

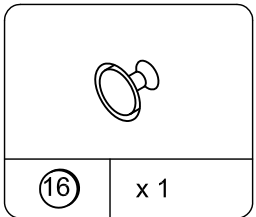

Knob  
Puno  
TWQ0030

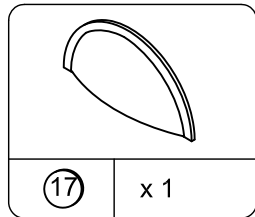

Pull  
Jalón  
TWQ0032

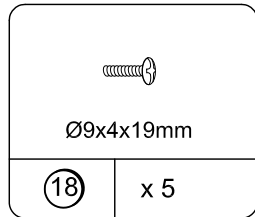

Screw bolt  
Tornillo con tuerca  
TWQ0033

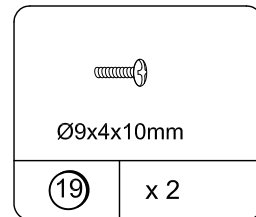

Screw bolt  
Tornillo con tuerca  
TWQ0034

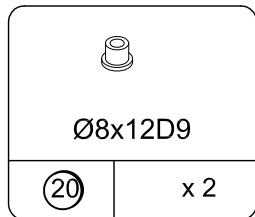

Door shaft support  
Soporte para eje de puerta  
TWQ0040

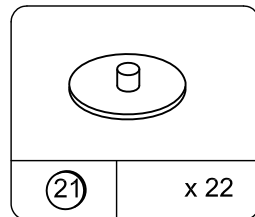

Cam cover  
Leva de cubierta  
TWQ0013

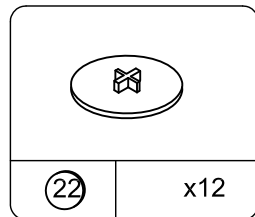

Cam cover  
Leva de cubierta  
TWQ0045

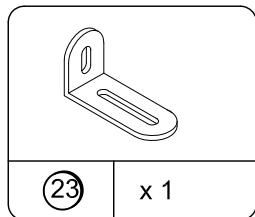

Wall bracket  
Soporte para la pared  
TWQ0046

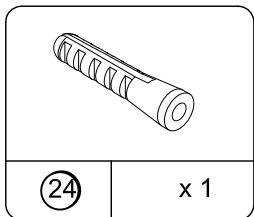

Wall anchor  
Ancla de pared  
TWQ0047

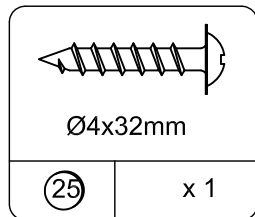

Screw  
Tornillo  
TWQ0048

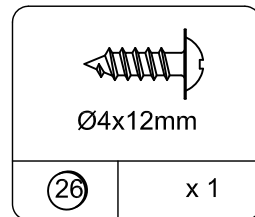

Screw  
Tornillo  
TWQ0049

This illustration shows how the cam fastening system works.  
Esta ilustración muestra como funciona el sistema de fijación de leva.

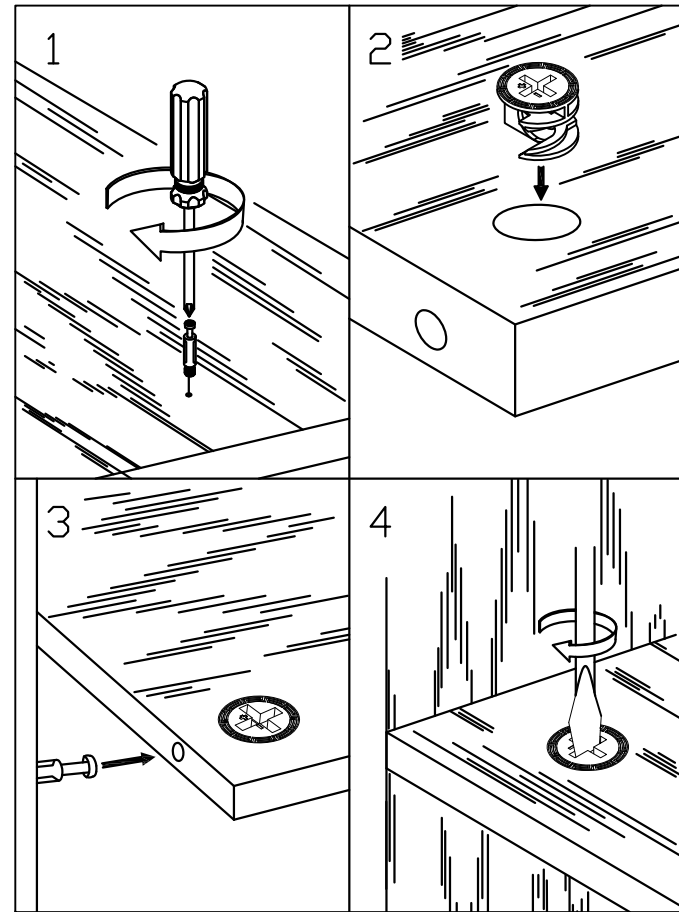

To view a video on how the cam fastening system works, download a free QR-reader on your smartphone, then scan the code.



Para ver un video de como funciona el sistema de sujeción cam, descargue una aplicación gratis que podra ver en su teléfono movil, entonces escnee el código.

# 1

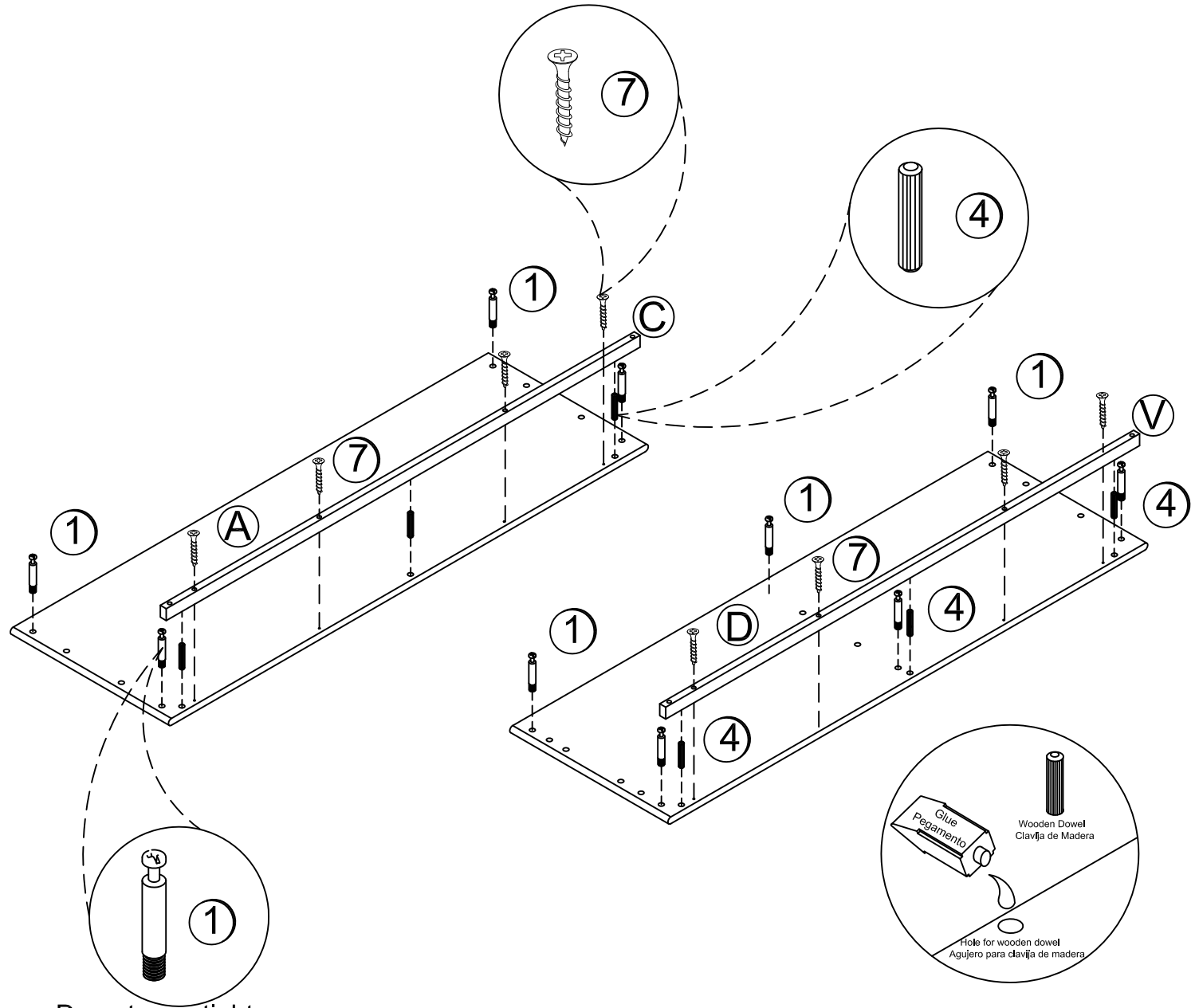
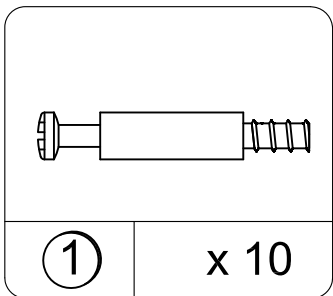
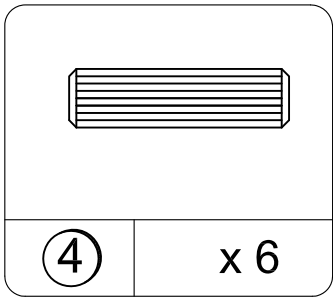
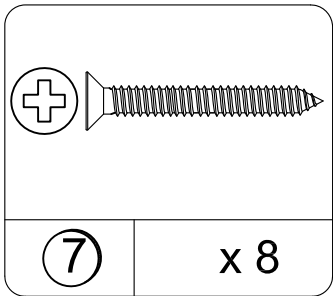

Do not over tighten  
No lo presione tanto

Use one drop of glue in dowel hole.  
Use una gota de pegamento en el agujero de clavija.

# 2

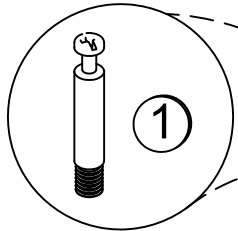

Do not over tighten  
No lo presione tanto

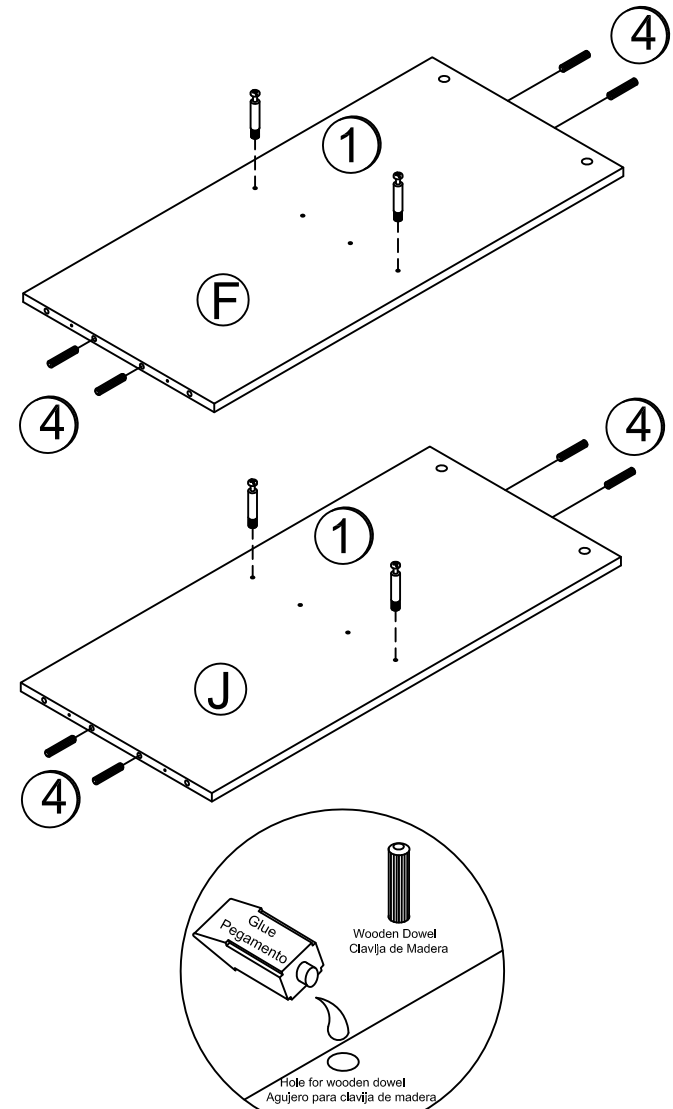
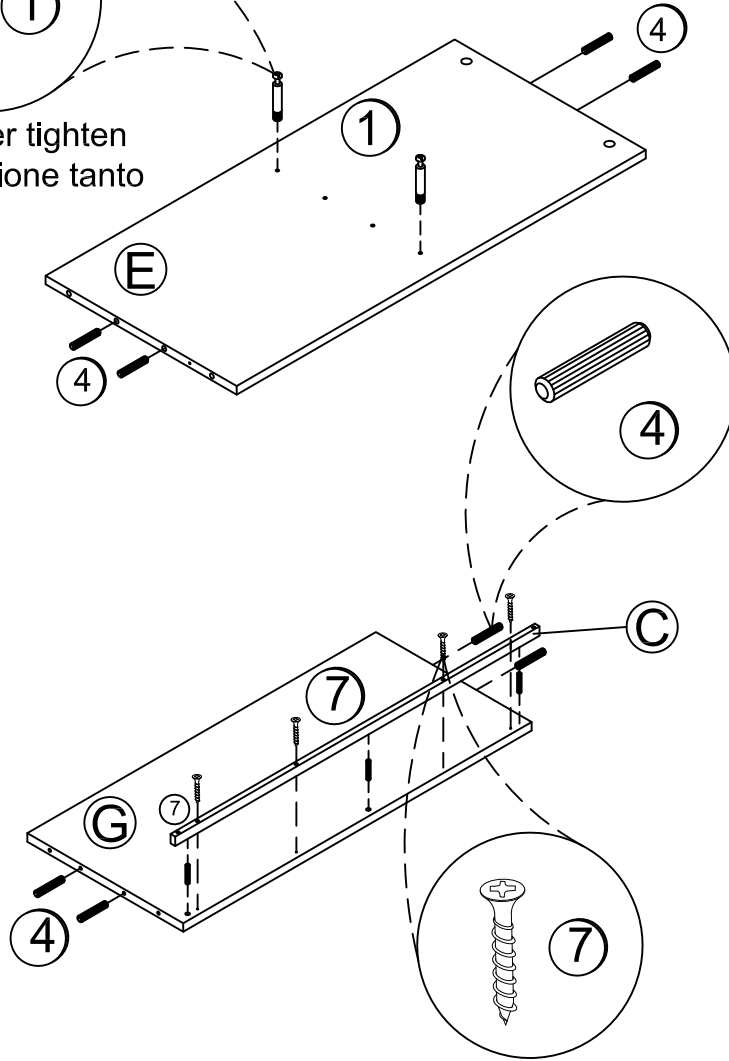

Use one drop of glue in dowel hole.  
Use una gota de pegamento en el agujero de clavija.

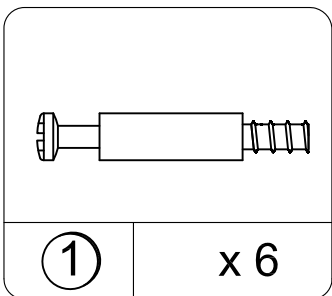
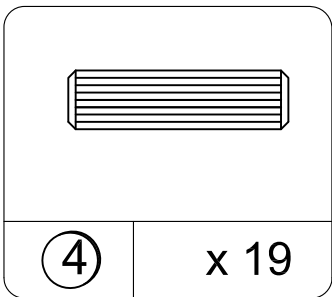
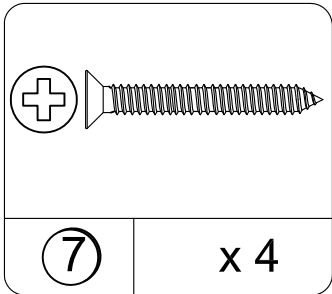



# 3

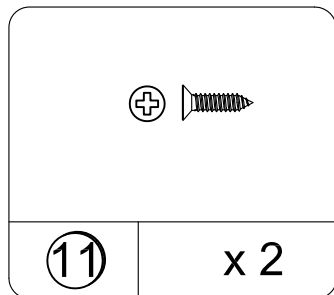
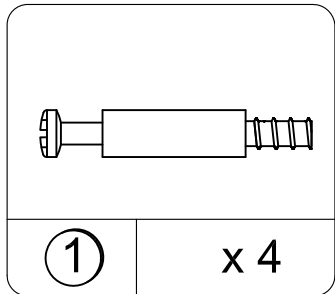
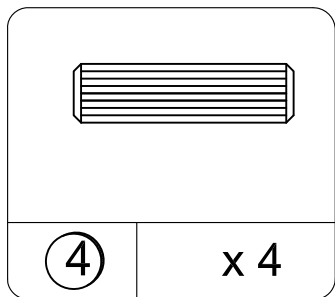
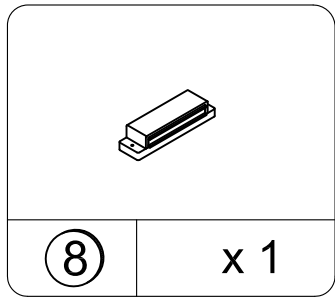

Do not over tighten  
No lo presione tanto

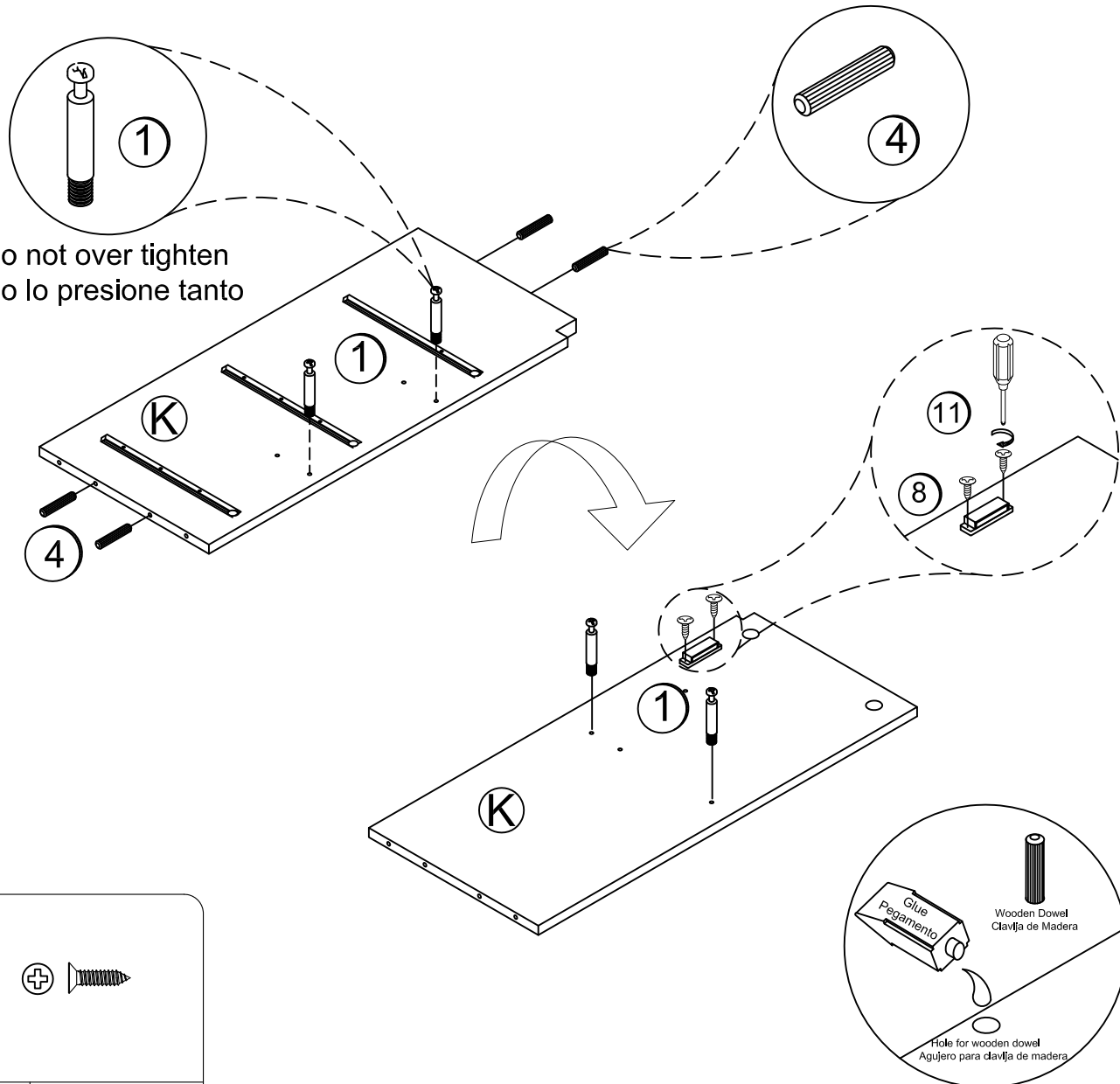

Use one drop of glue in dowel hole.  
Use una gota de pegamento en el agujero de clavija.

# 4

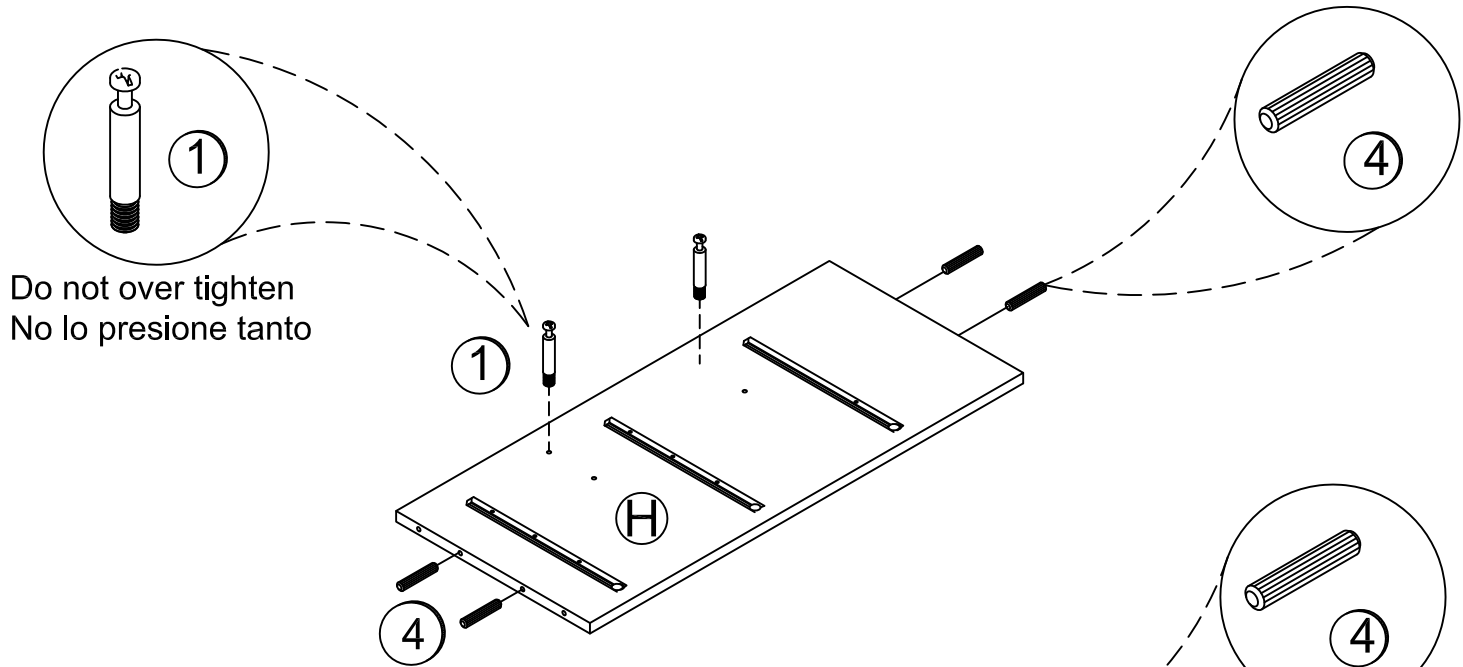

Do not over tighten  
No lo presione tanto

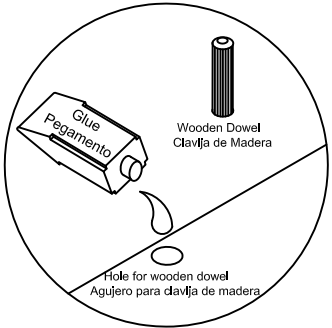
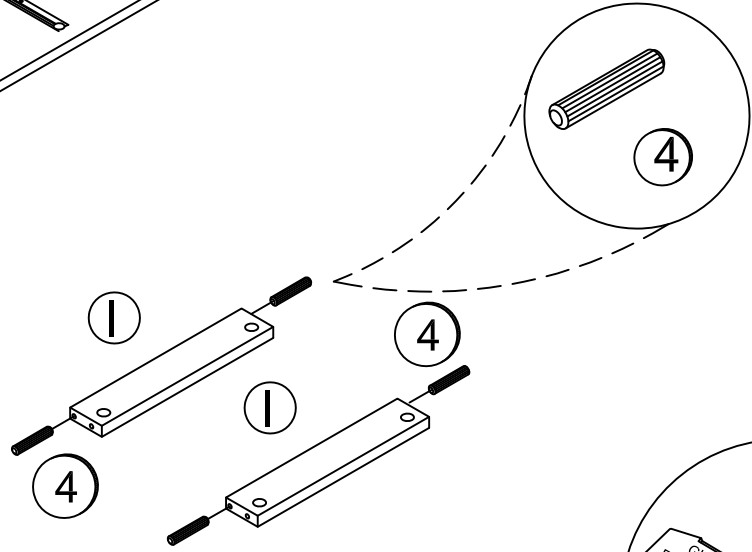
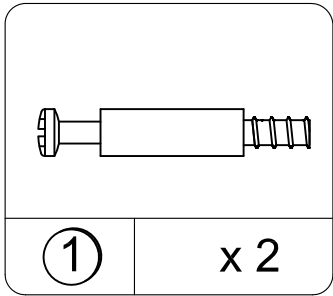
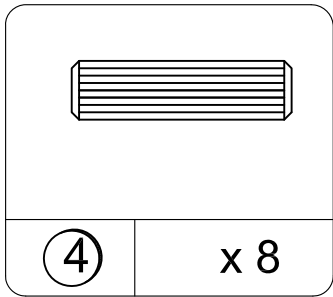

Use one drop of glue in dowel hole.  
Use una gota de pegamento en el agujero de clavija.

# 5

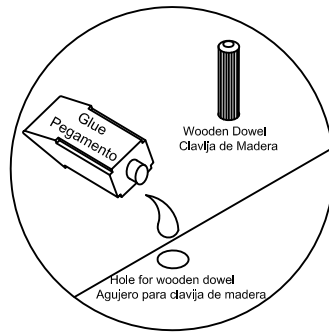
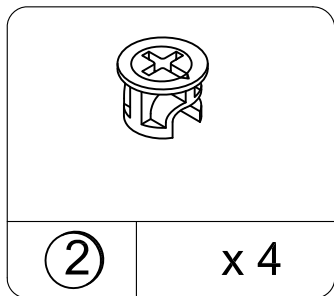
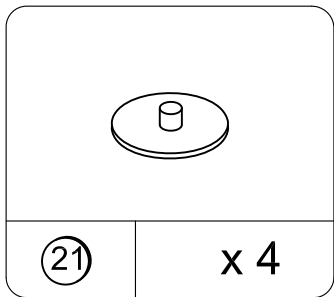
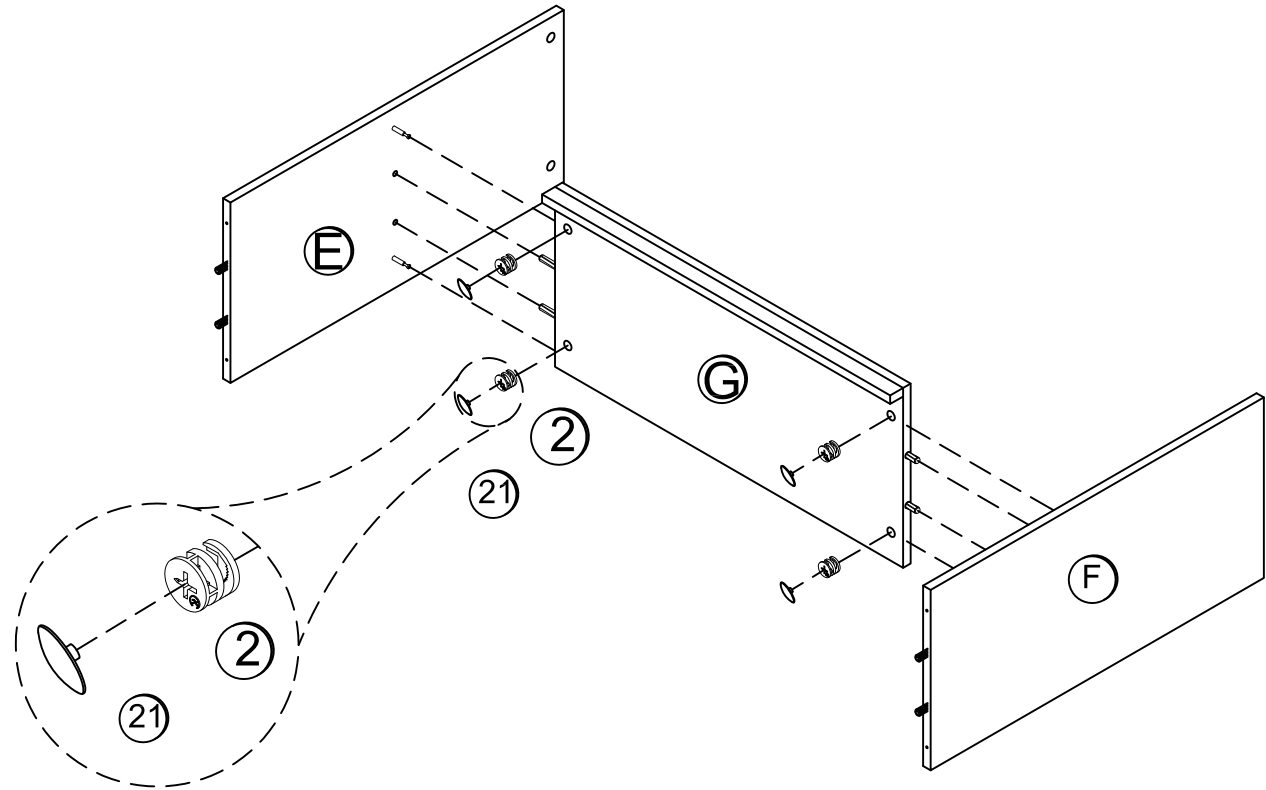

Use one drop of glue in dowel hole.  
Use una gota de pegamento en el agujero de clavija.

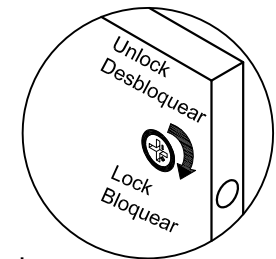
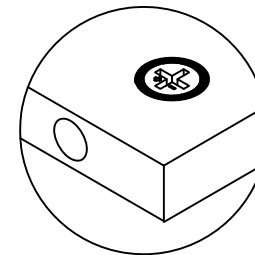

Proper orientation of cam lock  
La orientacion apropiada para el seguro de bloqueo

# 6

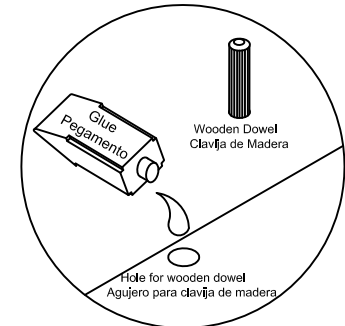

Use one drop of glue in dowel hole.  
 Use una gota de pegamento en el agujero de clavija.

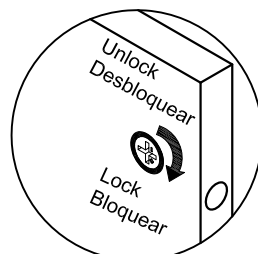
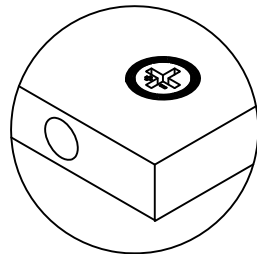
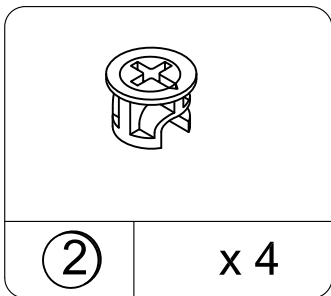
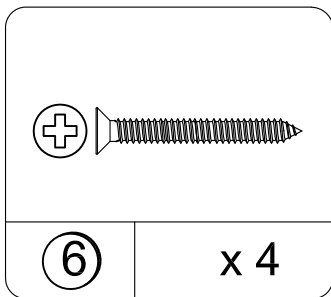
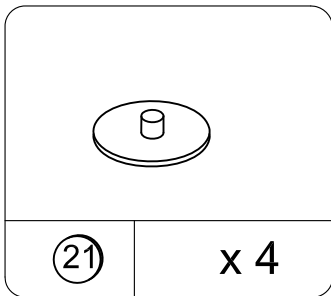
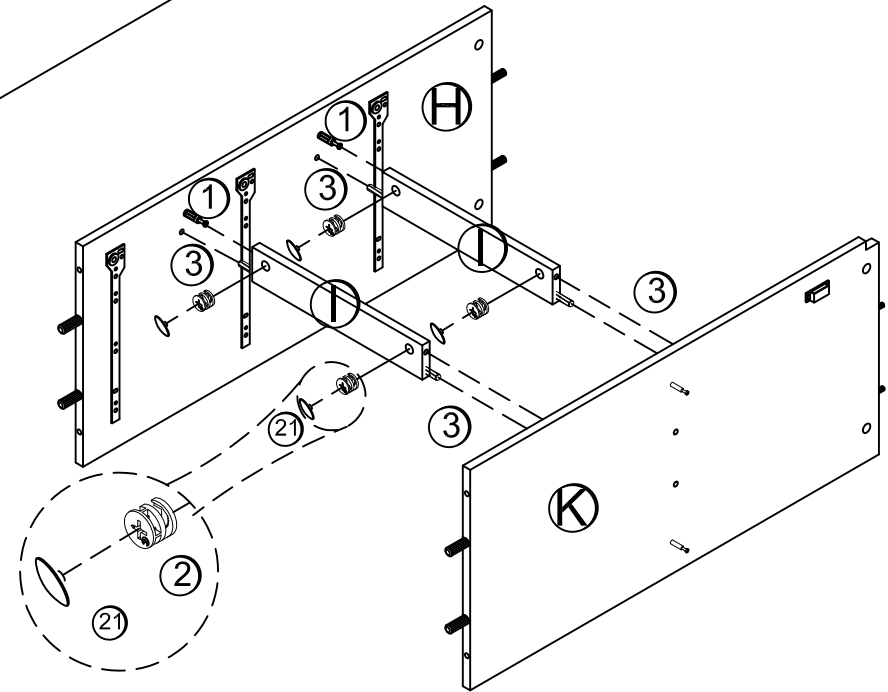
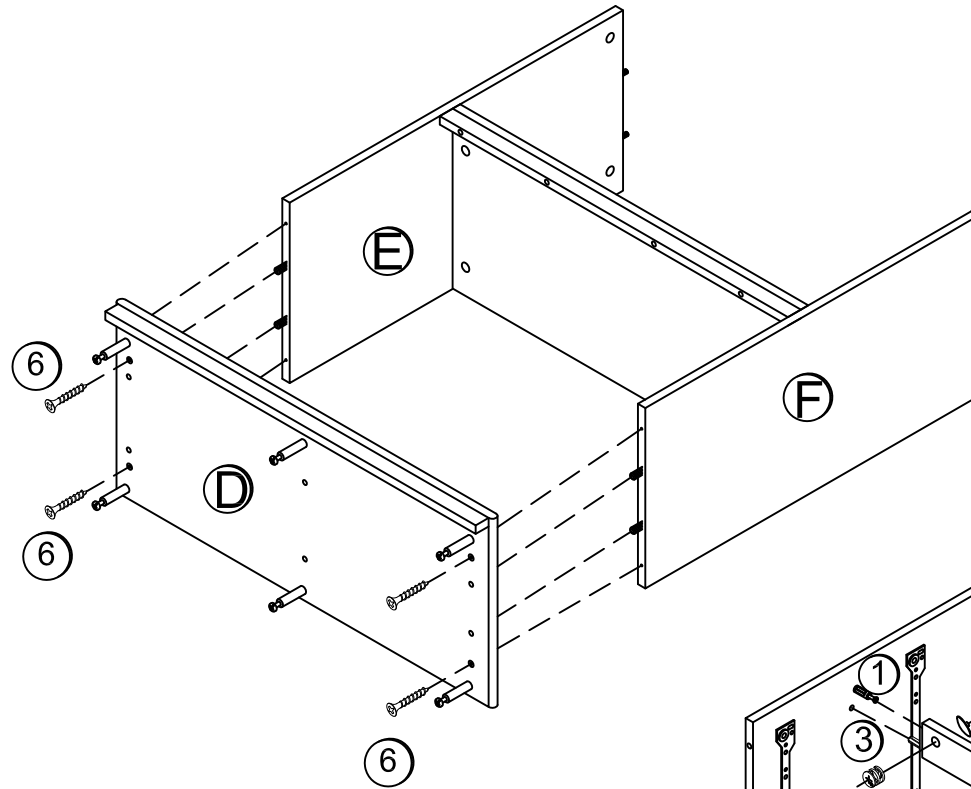

Proper orientation of cam lock  
 La orientacion apropiada para el seguro de bloqueo

# 7

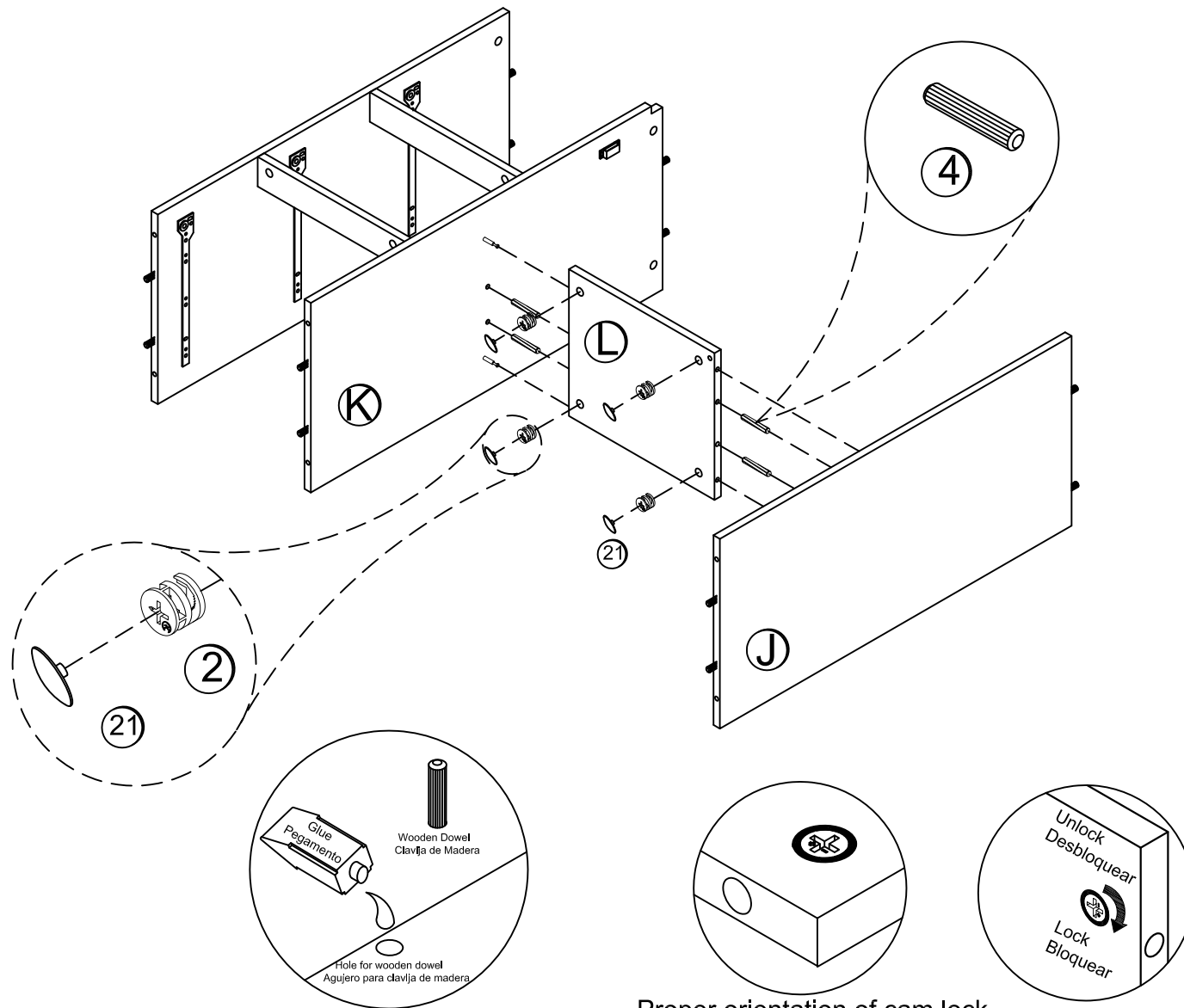
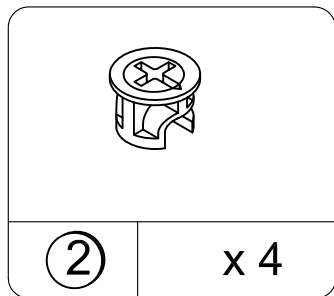
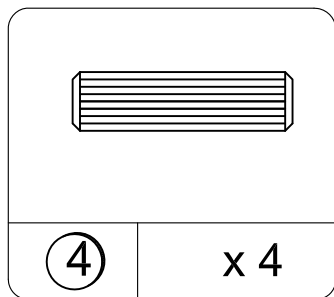
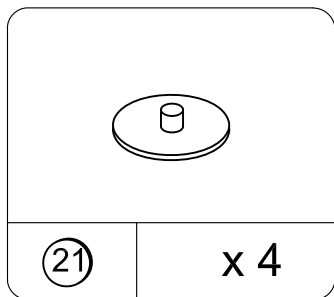

Use one drop of glue in dowel hole.  
Use una gota de pegamento en el agujero de clavija.

Proper orientation of cam lock  
La orientacion apropiada para el seguro de bloqueo

# 8

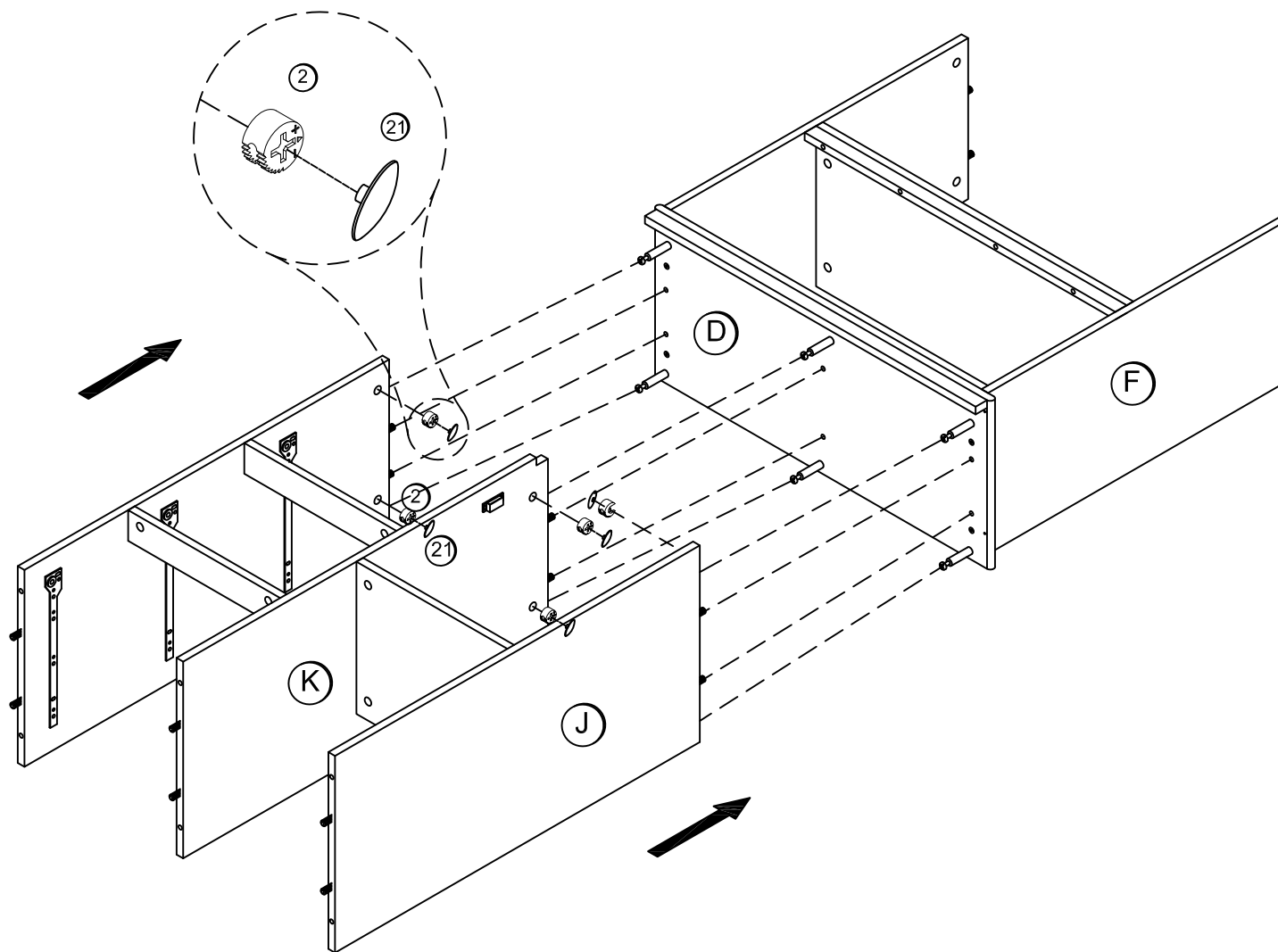
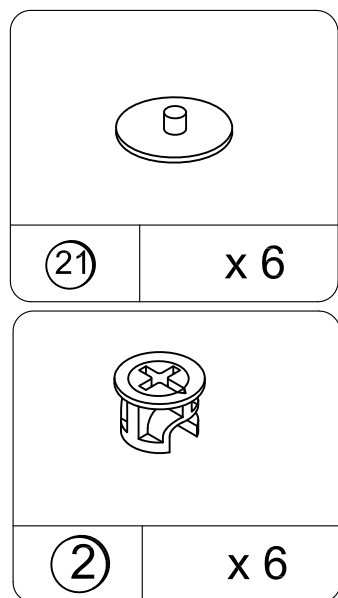

# 9

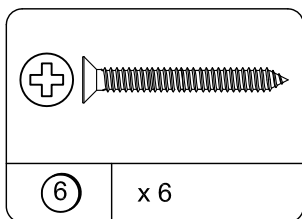
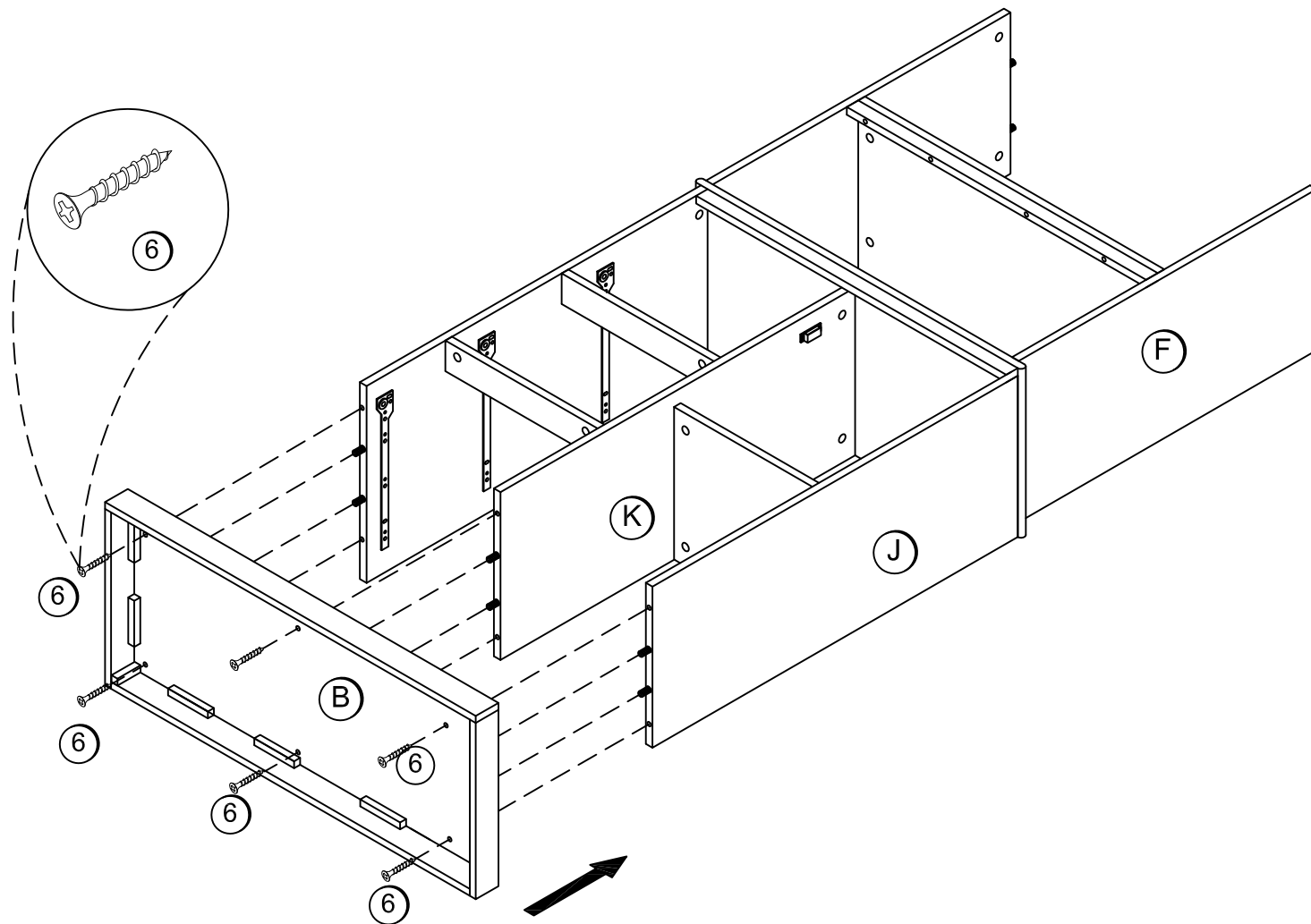

# 10

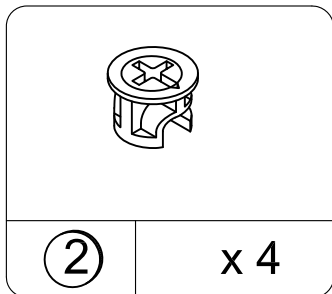
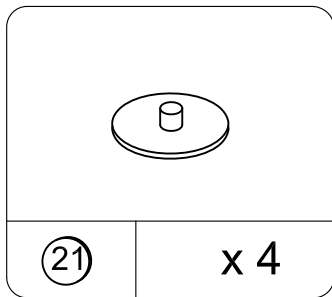
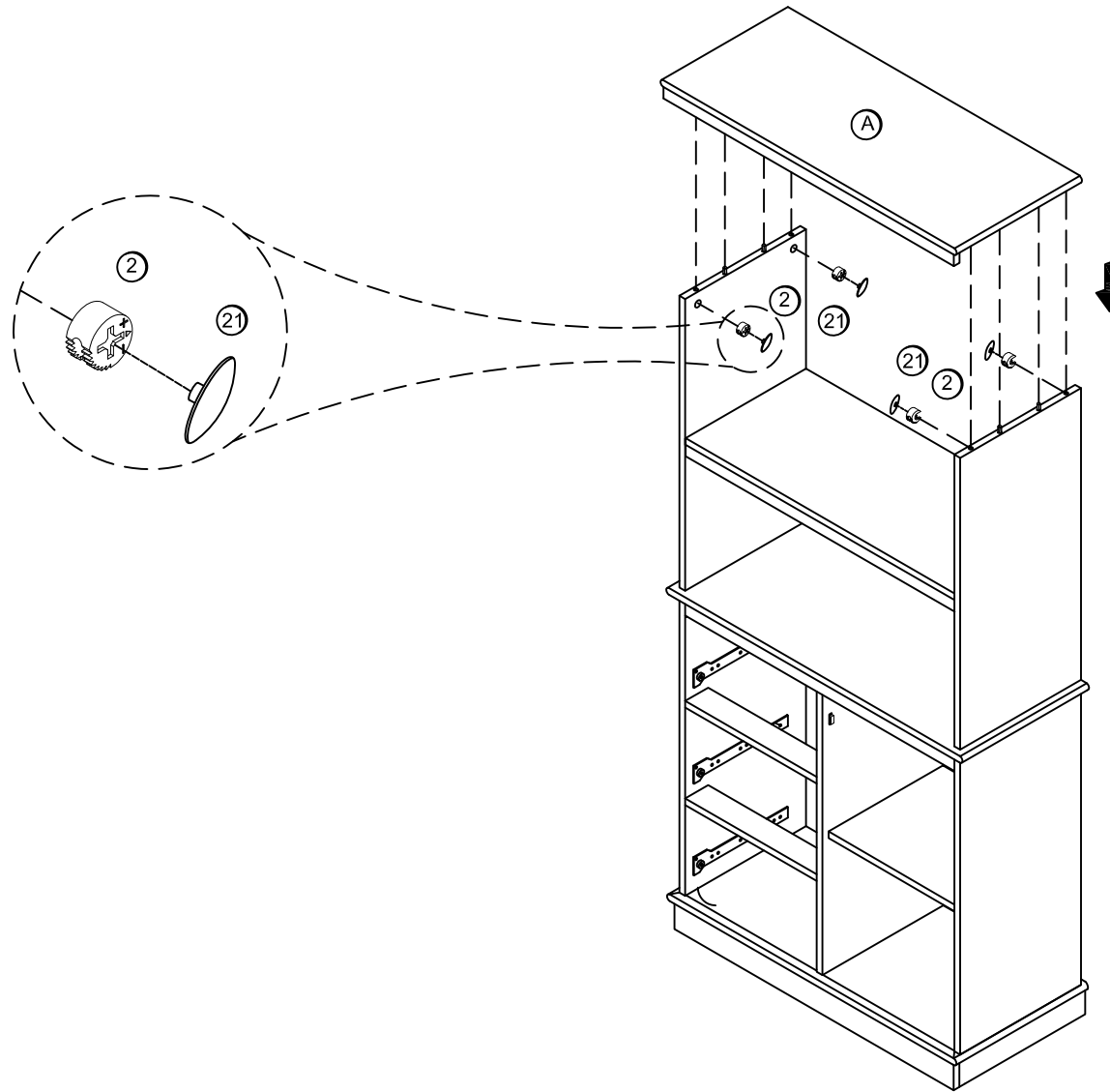



# 11

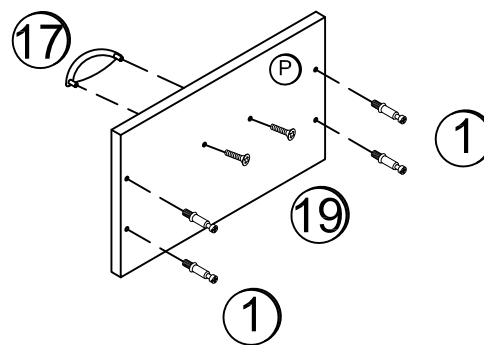
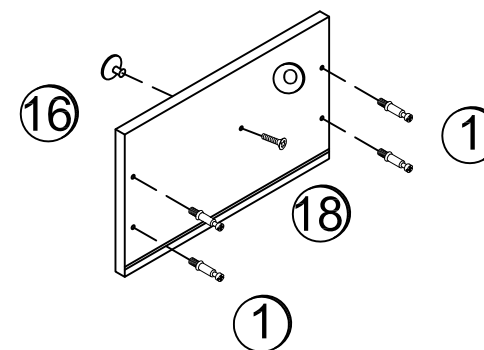
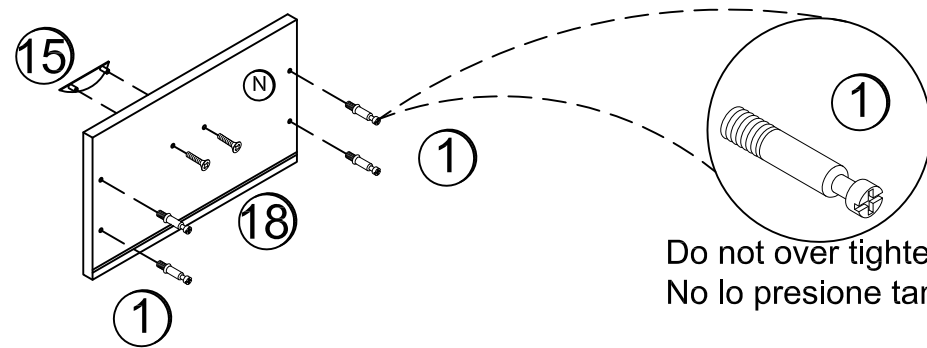
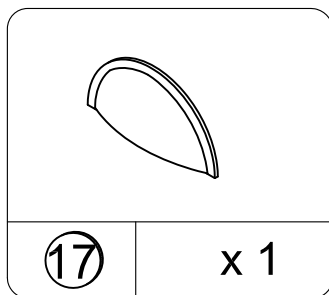
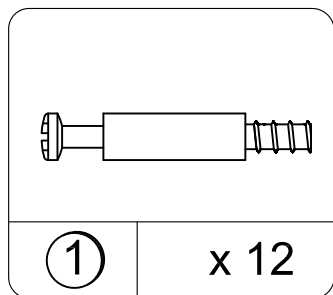
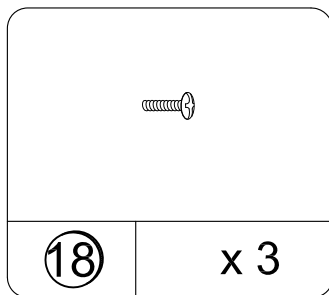
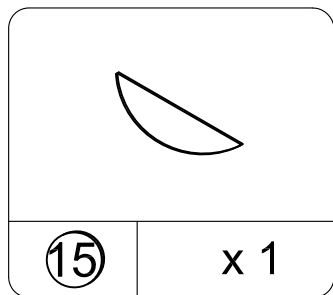
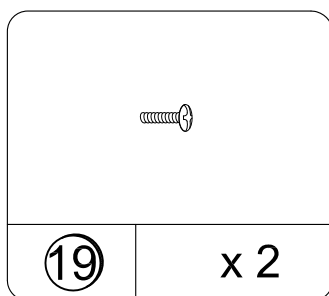
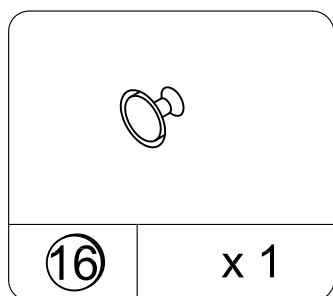

# 12

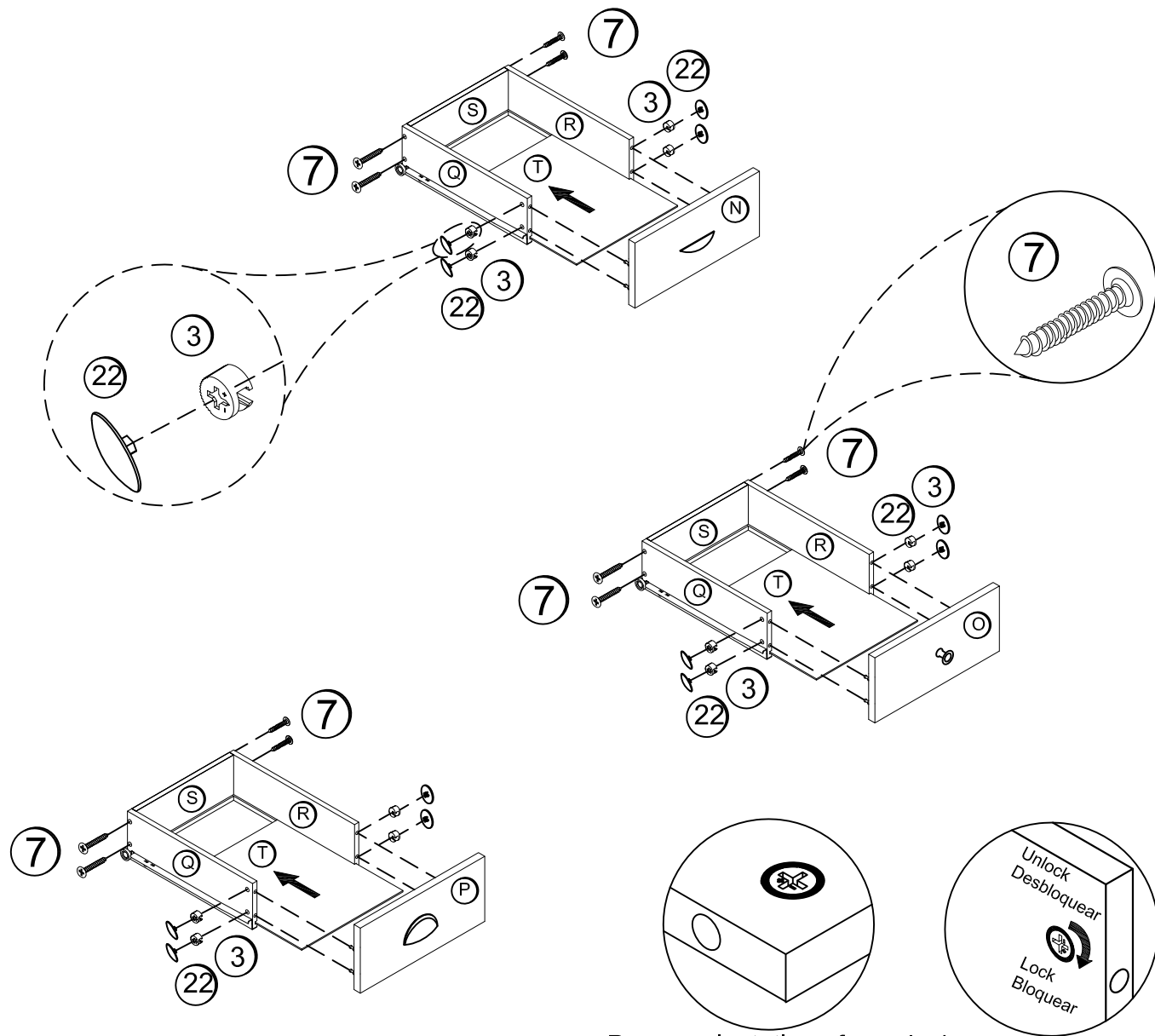
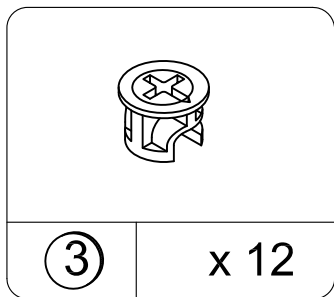
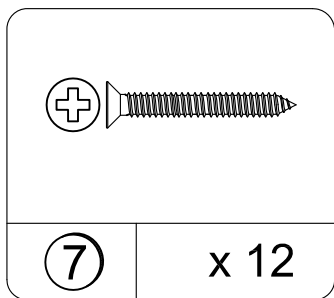
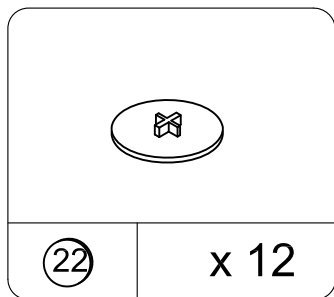

Proper orientation of cam lock  
La orientación apropiada para el seguro de bloqueo

# 13

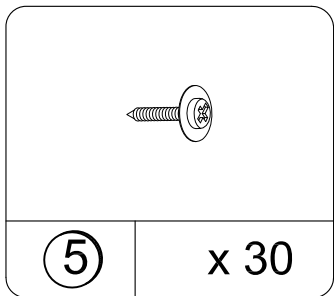
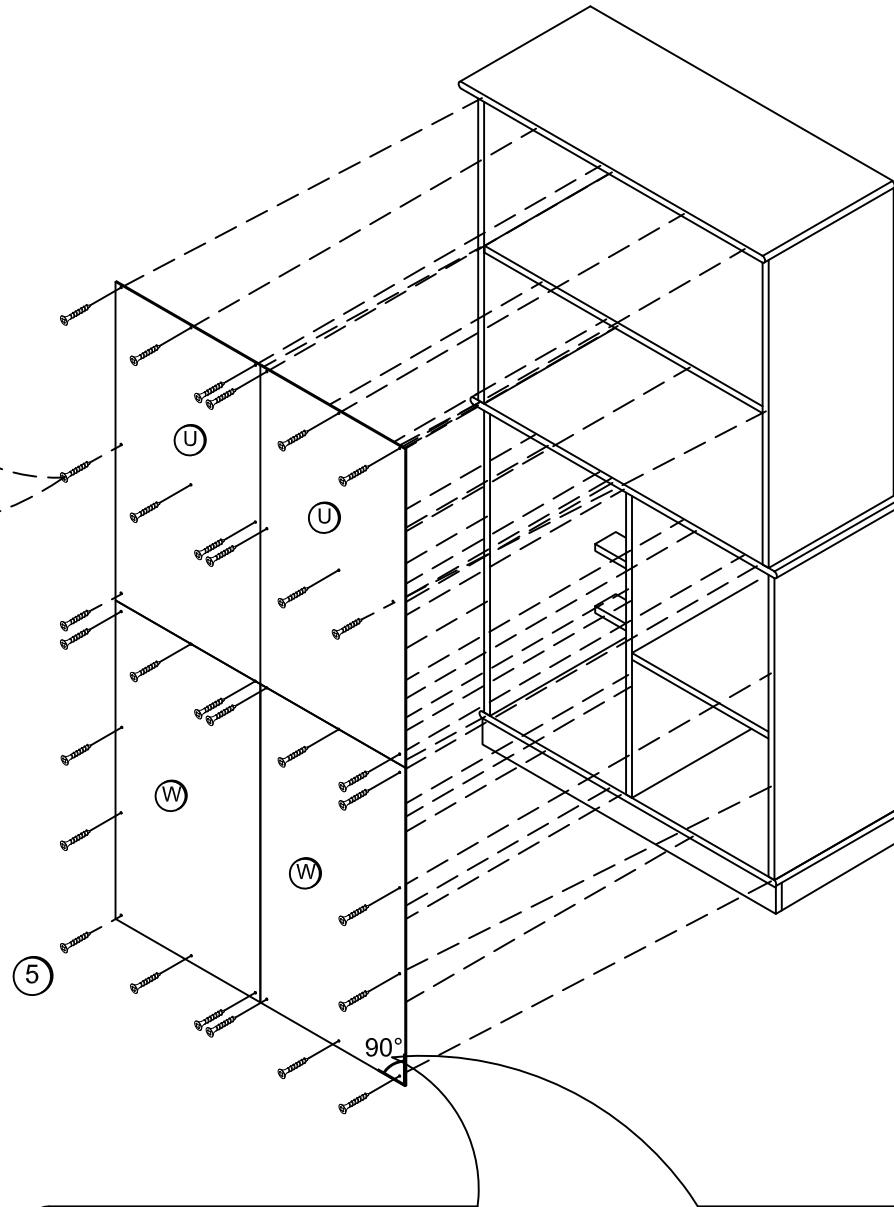
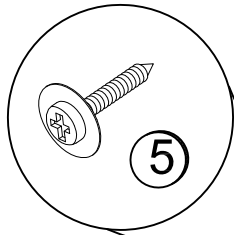

Before attaching the back panel, be sure that the unit is at 90°.  
Antes de atar el panel trasero, asegúrese de que la unidad está a 90°.

# 14

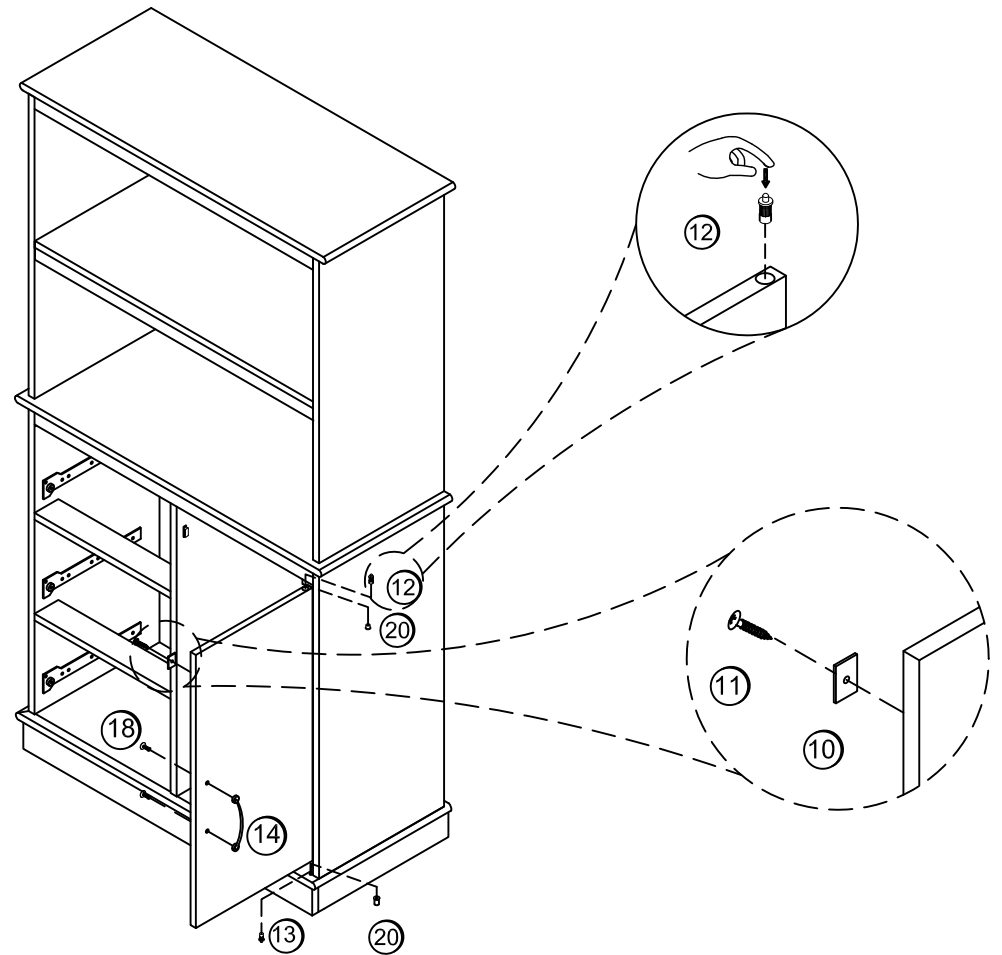
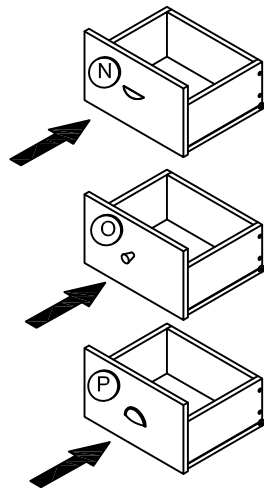
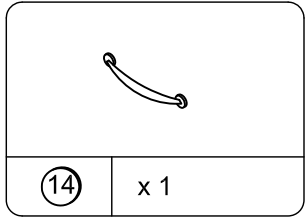
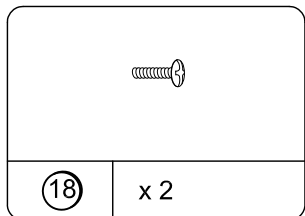
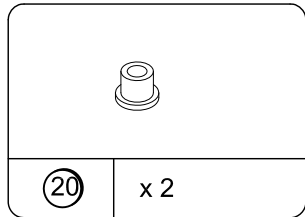
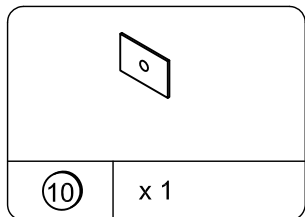
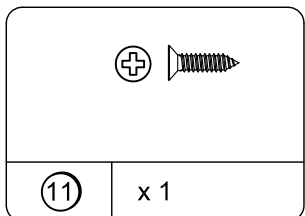
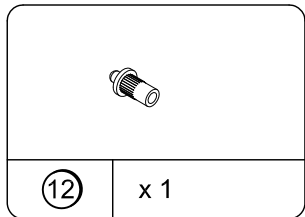
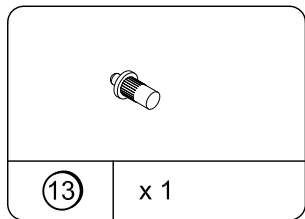

# 15

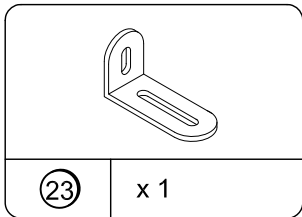
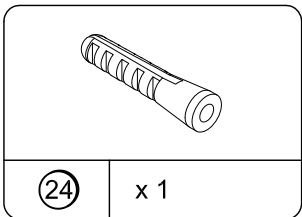
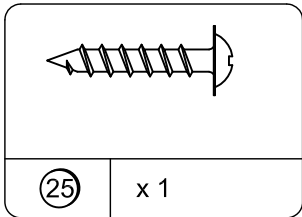
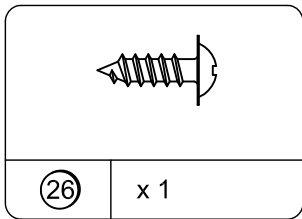
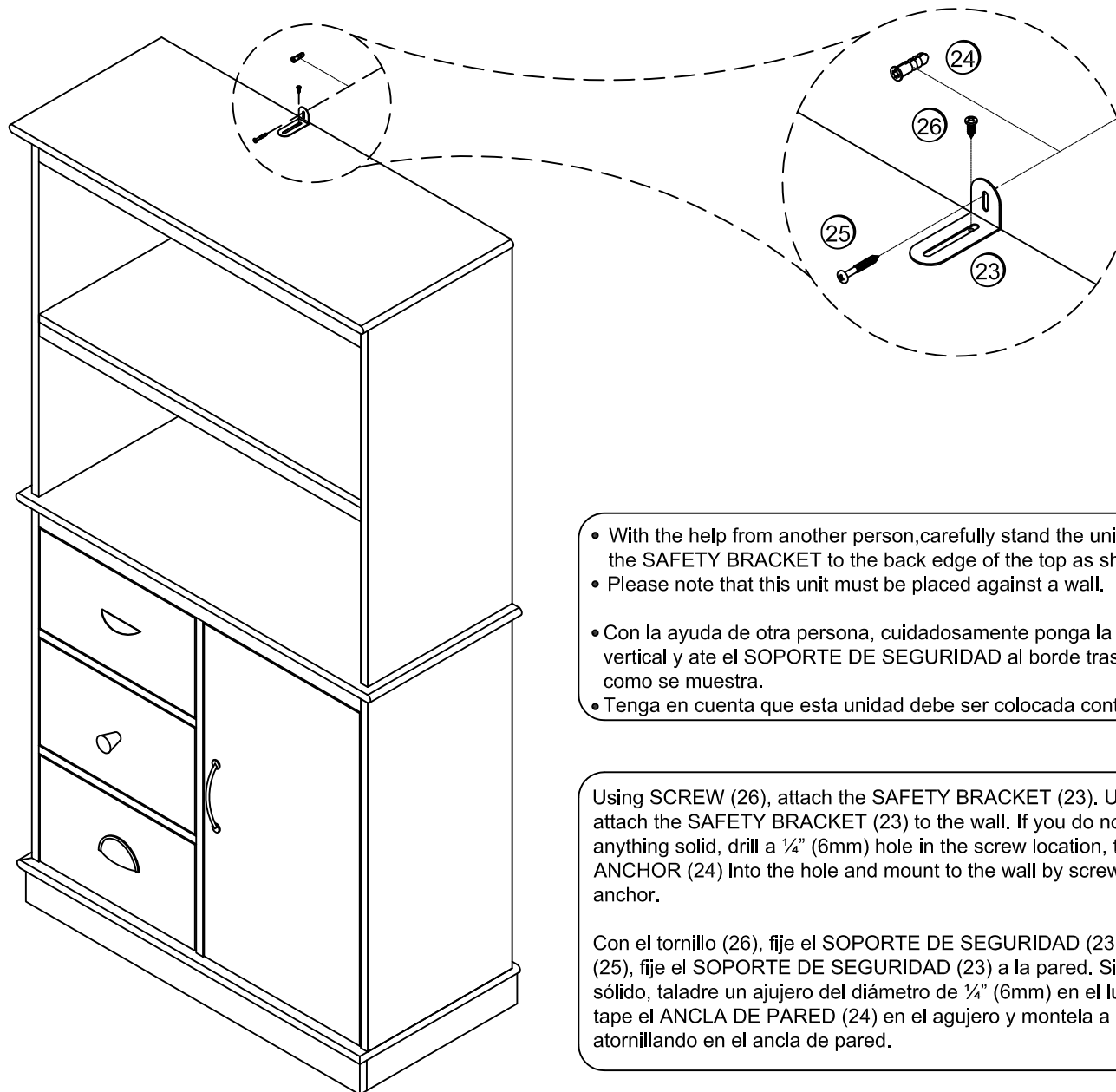

- With the help from another person, carefully stand the unit upright and attach the SAFETY BRACKET to the back edge of the top as shown.
- Please note that this unit must be placed against a wall.
- Con la ayuda de otra persona, cuidadosamente ponga la unidad en posición vertical y ate el SOPORTE DE SEGURIDAD al borde trasero de la superficie como se muestra.
- Tenga en cuenta que esta unidad debe ser colocada contra una pared.

Using SCREW (26), attach the SAFETY BRACKET (23). Using SCREW (25), attach the SAFETY BRACKET (23) to the wall. If you do not screw into anything solid, drill a ¼" (6mm) hole in the screw location, tap the WALL ANCHOR (24) into the hole and mount to the wall by screwing into the wall anchor.

Con el tornillo (26), fije el SOPORTE DE SEGURIDAD (23). Con el tornillo (25), fije el SOPORTE DE SEGURIDAD (23) a la pared. Si no atornilla en algo sólido, taladre un agujero del diámetro de ¼" (6mm) en el lugar del tornillo, tape el ANCLA DE PARED (24) en el agujero y montela a la pared atornillando en el ancla de pared.

WEIGHT LIMITS:  
LÍMITES DE PESO:

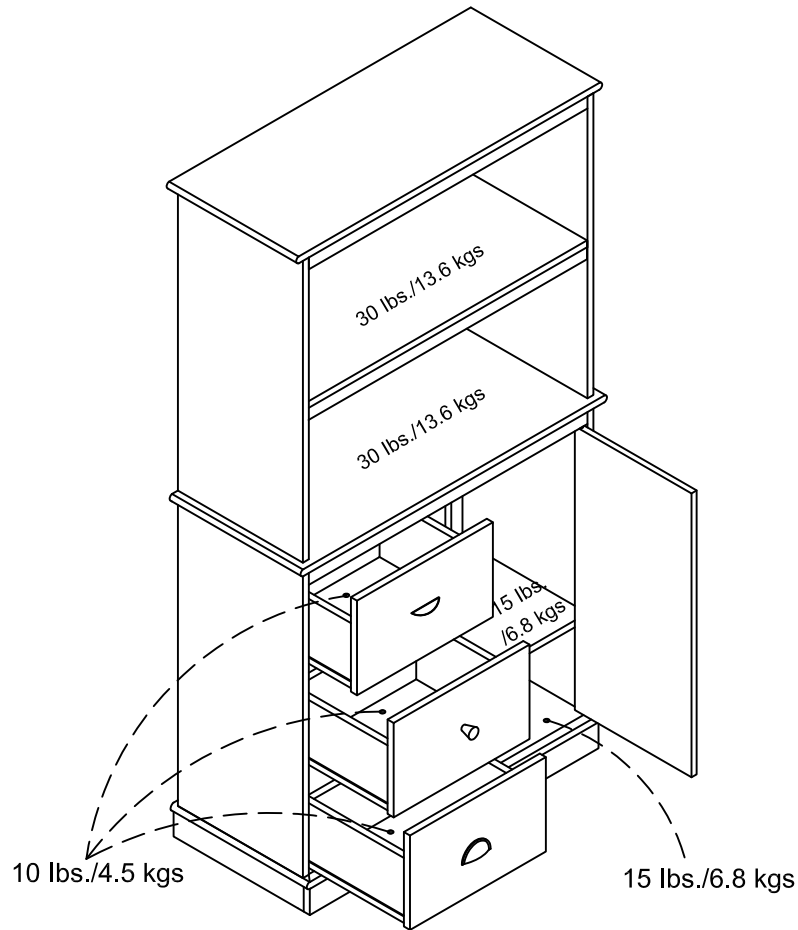

Enjoy Your Furniture  
DISFRUTE DE SU MUEBLE

This unit has been designed to support the maximum loads shown. Exceeding these load limits could cause sagging, instability, product collapse, and/or serious injury.

Esta unidad se ha diseñado para apoyar las cargas máximas mostradas. Exceder estos límites de carga podría causar ceder, inestabilidad, derrumbamiento del producto, y/o lesión seria.

**▲ WARNING**

Please make sure that all objects are removed before moving the assembled unit.

The unit must be team lifted, not dragged or pushed.

Failure to do so could cause instability, product collapse, and/or serious injury.

**▲ ADVERTENCIA**

Por favor mueva el mueble cuidadosamente con la ayuda de otra persona. Levante y mueva el mueble a su lugar. No lo arrastre o empuje, de lo contrario puede haber inestabilidad en el mueble y este puede colapsar u ocasionar graves lesiones.