

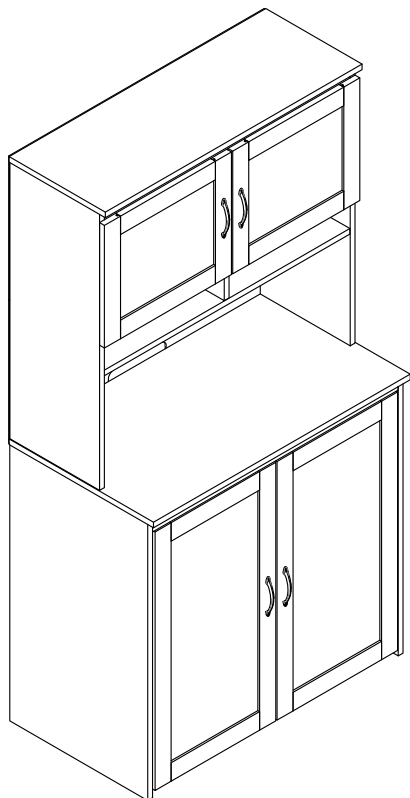

# 9364096



THIS INSTRUCTION BOOKLET CONTAINS **IMPORTANT** SAFETY INFORMATION. PLEASE READ AND KEEP FOR FUTURE REFERENCE.

ESTE FOLLETO DE INSTRUCCION CONTIENE INFORMACION **IMPORTANTE** DE SEGURIDAD. POR FAVOR LEA Y GUARDE PARA REFERENCIA FUTURA.



**DO NOT RETURN PRODUCT TO THE STORE**  
Individual stores do not stock parts.

**NO DEVUELVA ESTE PRODUCTO A LA TIENDA**  
Las tiendas no almacenan partes.

Lot Number / Número de Lote: \_\_\_\_\_

Date Of Purchase / Fecha de Compra: \_\_\_\_/\_\_\_\_/\_\_\_\_

If a part is missing or damaged, call our toll-free customer service line. We will gladly ship your replacement parts **FREE** of charge.

Si faltan partes o piezas, o éstas están dañadas, llame gratis al teléfono de servicio al cliente. Con gusto le enviaremos las partes sin cargo alguno.

Need Parts or Assistance?  
Necesitas partes o asistencia?

**1-800-489-3351**

or access our website  
o visite nuestra página de internet

**www.altrafurniture.com**

For prompt, reliable service please have your assembly manual ready.  
Para obtener servicio rapido y confiable, por favor tenga esta manual a la mano.

Recommended # of people needed for assembly: 2

El número recomendado de personas necesarias para el montaje: 2

B34936409600

Thank you for purchasing from Altra Furniture.  
Visit [www.altrafurniture.com](http://www.altrafurniture.com) to view the limited warranty valid in the U.S. and Canada.

## ALTRA FURNITURE CUSTOMER SERVICE

Gracias por haber comprado de Altra Furniture.  
Visitar [www.altrafurniture.com](http://www.altrafurniture.com) para mirar la garantía limitada válida solamente en U.S.A y Canada.

## SERVICIO A LA CLIENTE DE ALTRA FURNITURE

### Before starting - Antes de empezar.

- Read each step carefully before starting. It is very important that each step of instruction is performed in the correct order. If these steps are not followed in sequence, assembly difficulties will occur.  
Leer con cuidado cada paso antes de empezar. Es muy importante de ejecutar cada paso en el orden correcto. Si los pasos no están ejecutados en secuencia, ocurrirán dificultades en el montaje.
- Make sure all parts are included. Most board parts are labeled or stamped on the raw edge. Asegurar que todas las piezas son incluidas. La mayoría de las tablas tienen las etiquetas o los sellos en el lado sin acabado.
- Work in spacious area, preferably on a carpet, near the place the unit will be used.  
Trabajar en una área espaciosa, preferible sobre alfombra, cerca del lugar donde se va a usar el mueble.
- Have the following tools close at hand.  
Tener las herramientas siguientes cerca de la mano.
- Do not use power tools to assemble your furniture. Power tools may strip or damage the parts.  
No use herramienta eléctrica para montar su unidad. Las herramientas eléctricas pueden dañar las piezas.

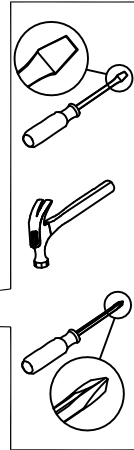

Call us at: **1-800-489-3351**  
(in U.S.A. only)  
Llamar a: (Solo en U.S.A)

Monday - Friday 7:00 am - 8:00 pm Central Time	Saturday 9:00 am - 5:00 pm Central Time
--	---



Fax: **1-636-745-1005**  
Fax:

Lunes - Viernes 7:00h - 20:00h Tiempo Central	Sábado 9:00h - 17:00h Tiempo Central
---	--



Visit our Website:  
Visitar nuestro website: [www.altrafurniture.com](http://www.altrafurniture.com)



Write to: **ALTRA FURNITURE**  
Escribir a: 410 East 1st Street South Wright City, MO 63390 USA  
Attn: Service Dept.

### HELPFUL HINTS

- Visit our website for assembly video clips.
- Identify, sort and count the parts before attempting assembly.
- Call our toll free number if you need assistance identifying parts.
- Compression dowels are tapped in with a hammer.
- Slides have lips only on the right side.
- Cam locks that are properly fastened on a horizontal board will face toward the center of the unit, on a vertical board the point on the lock will face the bottom.
- Back panels provide stability and support. Use all the nails provided.
- When tapping nails into a board, be sure there are equal margins on all sides to square the unit.
- Units without the back panel installed may collapse.
- Clean the product with your favorite furniture polish and a soft cloth. **DO NOT USE** harsh chemicals or abrasive cleaners.
- Move your new furniture carefully, with two people lift and carry the unit to its new location.
- Never push, drag or scoot your furniture (especially on carpet).
- Your furniture can be disassembled and reassembled to move.
- Additional parts are available for a nominal fee.

### NOTES UTILES

- Visitar nuestro website para mirar los videos cortos del montaje.
- Identificar, clasificar y contar las piezas antes de intentar el montaje.
- Llamar gratis a nuestro número de servicio si necesita ayuda con identificar las piezas.
- Las clavijas de compresión se taladran con un martillo.
- Las correderas sólo tienen las protrusiones en el lado derecho.
- Las cerraduras de leva que se atan propiamente en una tabla horizontal se puntan al centro de la unidad, y las en una tabla vertical se puntan al fondo.
- Los paneles traseros se mantienen la estabilidad. Usar todos los tornillos proporcionados.
- A taladrar los tornillos en una tabla, asegurarse que hay márgenes iguales en todos los lados para cuadrar la unidad.
- Las unidades sin panel trasero pueden derrumbarse.
- Limpiar la unidad con su pulimento favorito de mueble y una tela suave. **NO UTILIZAR** productos con químicos duros o abrasivos.
- Mover su mueble nuevo cuidadosamente, con dos personas levantar la unidad a su nuevo lugar.
- Nunca empujar o arrastrar su mueble (especialmente en alfombra).
- Poderse desmontar y volver a montar su mueble de para mover.
- Piezas adicionales están disponibles para una cuota nominal.

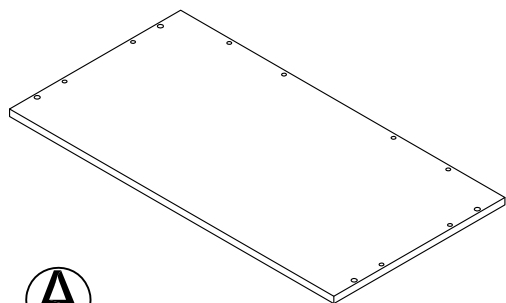

**A**

TOP  
Panel superior  
T9364096010

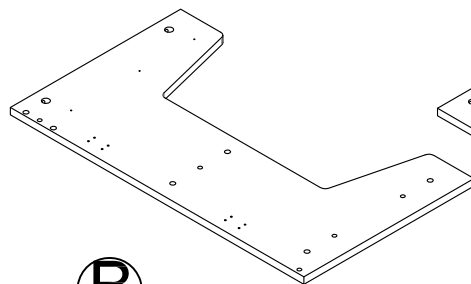

**B**

LEFT SIDE PANEL  
Panel izquierdo  
T9364096020

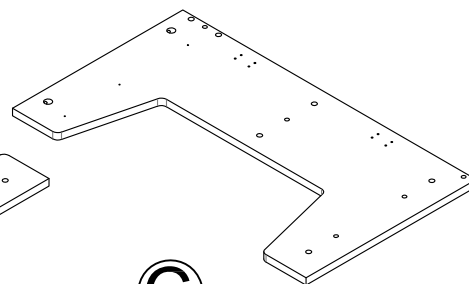

**C**

RIGHT SIDE PANEL  
Panel lateral derecho  
T9364096030

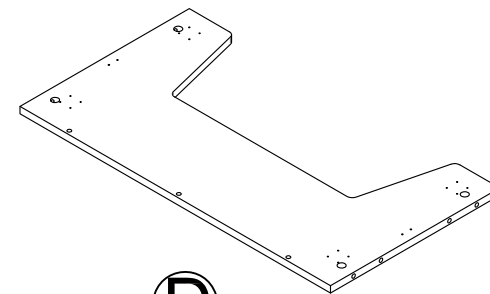

**D**

BOTTOM  
Base  
T9364096040

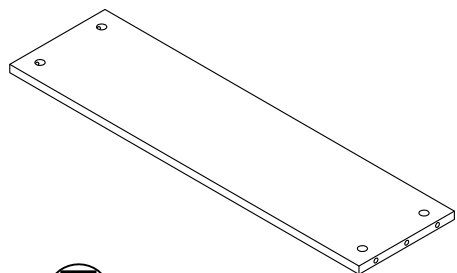

**E**

FIXED SHELF  
Repisa fija  
T9364096050

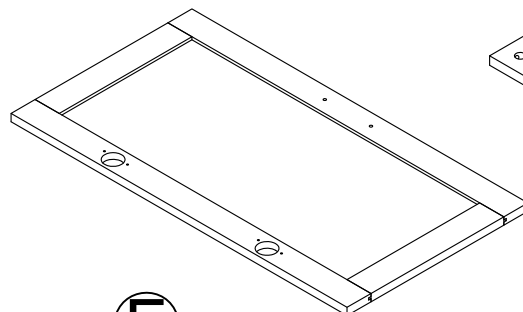

**F**

DOOR  
Puerta  
T9364096060  
QTY: 2

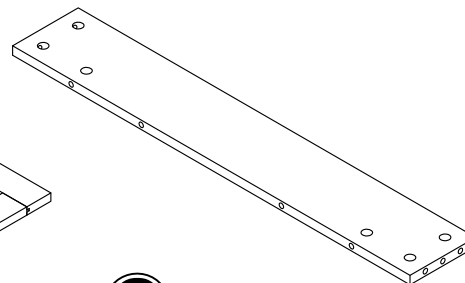

**G**

BACK RAIL  
Riel trasero  
T9364096070

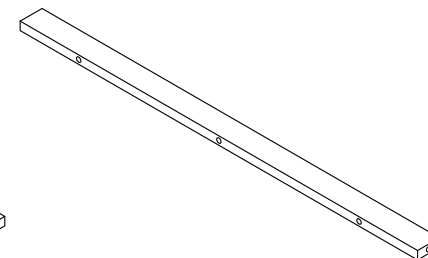

**H**

RAIL  
Riel  
T9364096080

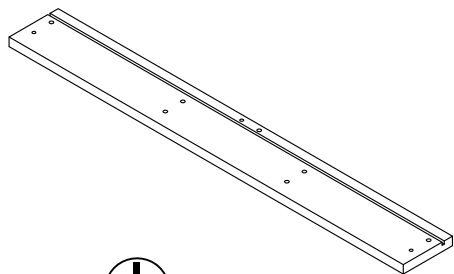

I

DRAWER FRONT  
Frente del cajón  
T9364096090

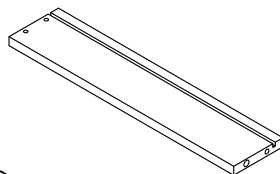

J

LEFT DRAWER SIDE  
Lado izquierdo del cajón  
T9364096100

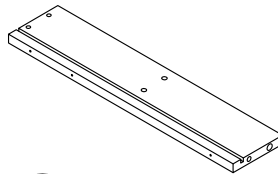

K

RIGHT DRAWER SIDE  
Lado derecho del cajón  
T9364096110

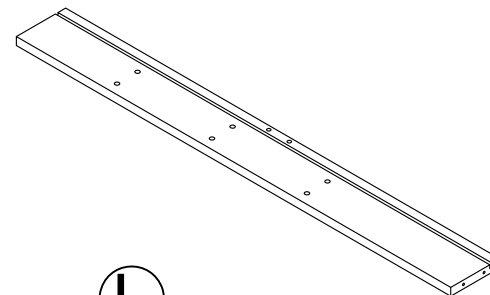

L

DRAWER BACK  
Panel trasero del cajón  
T9364096120

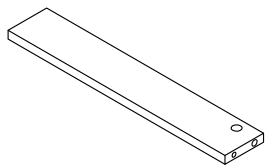

M

BOTTOM SUPPORT  
Soporte inferior  
T9364096130

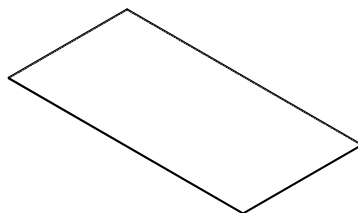

N

DRAWER BOTTOM  
Fondo del cajón  
T9364096140

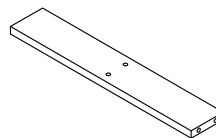

O

RAIL  
Riel  
T9364096150  
QTY:3

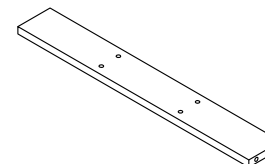

P

RAIL  
Riel  
T9364096160

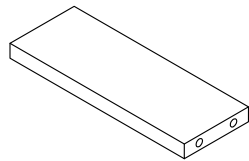

Q

RAIL  
Riel  
T9364096170

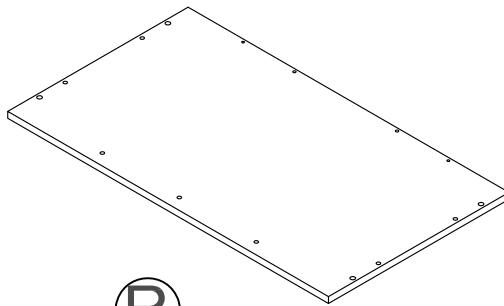

R

TOP  
Panel superior  
T9364096180

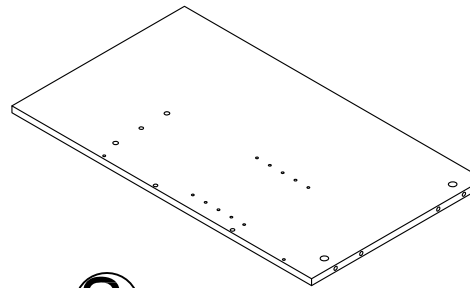

S

LOWER LEFT PANEL  
Panel izquierdo inferior  
T9364096190

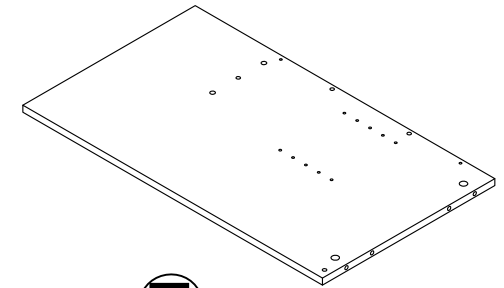

T

LOWER RIGHT PANEL  
Panel derecho inferior  
T9364096200

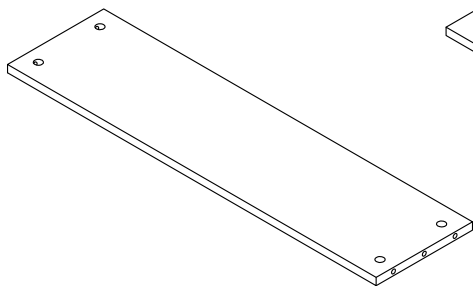

U

FIXED SHELF  
Repisa fija  
T9364096210

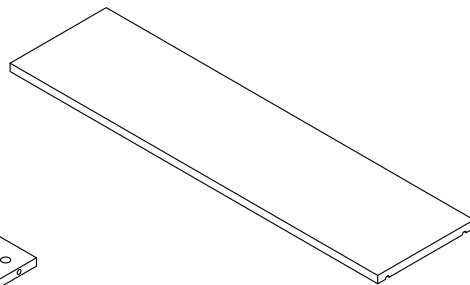

V

ADJUSTABLE SHELF  
Repisa ajustable  
T9364096220

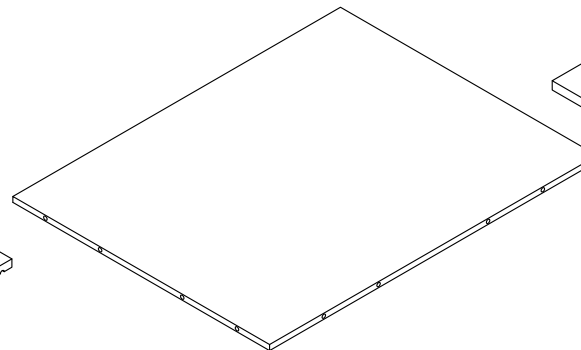

W

BACK PANEL  
Panel trasero  
T9364096230

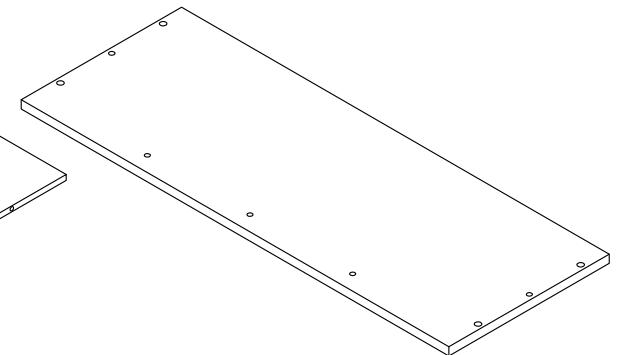

X

TOP  
Panel superior  
T9364096240

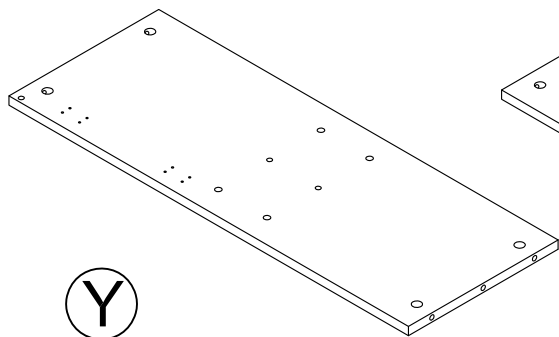

Y

UPPER LEFT PANEL  
Tabla izquierda superior  
T9364096250

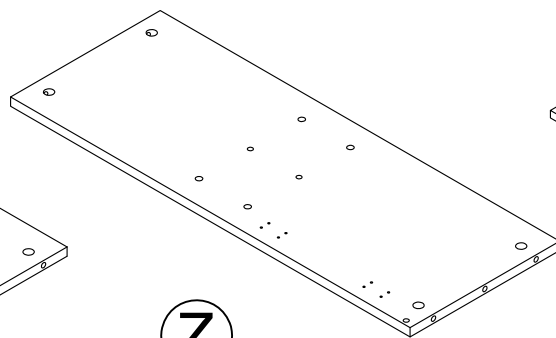

Z

UPPER RIGHT PANEL  
Tabla derecha superior  
T9364096260

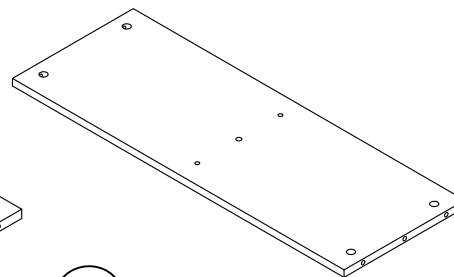

AA

FIXED SHELF  
Repisa fija  
T9364096270

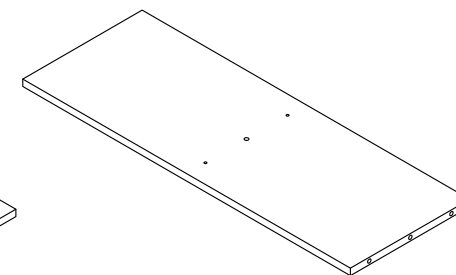

BB

FIXED SHELF  
Repisa fija  
T9364096280

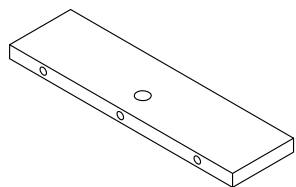

CC

PARTITION  
Partición  
T9364096290

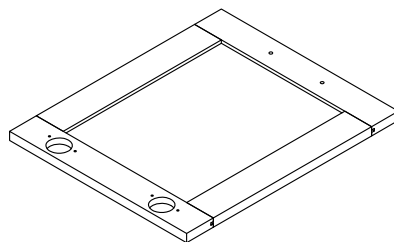

DD

DOOR  
Puerta  
T9364096300  
QTY: 2

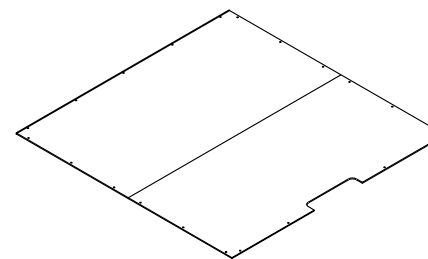

EE



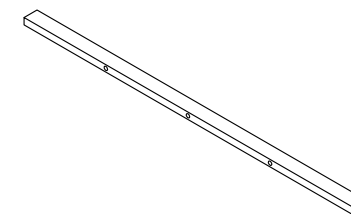





BACK PANEL  
Panel trasero  
T9364096310

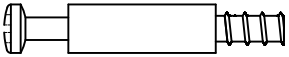

FF

RAIL  
Riel  
T9364096320  
QTY: 2

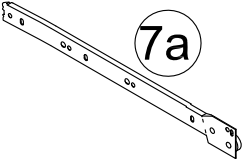
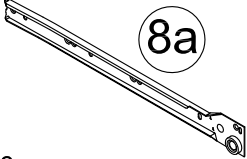
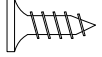
PARTS -PIEZAS

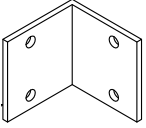
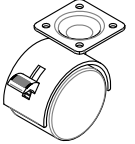
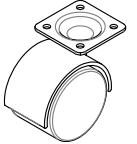
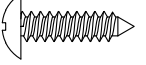
 M6 x 28mm	 Ø15 x 11mm	 Ø6 x 28mm	 Ø12 x 10mm	 Ø8 x 30mm	 Ø6 X 30mm
① x 44	② x 44	③ x 9	④ x 9	⑤ x 45	⑥ x 29
CAM BOLT Tornillo de rosca TWF4428	CAM LOCK Tornillo de cerradura TWF4415	Cam Bolt Perno de la Leva TWF4433	CAM LOCK Tornillo de cerradura TWF4412	WOOD DOWEL Clavija de madera TWF4530	WOOD DOWEL Clavija de Madera TWF4531
left cabinet member corredera de mueble izquierda		right cabinet member corredera de mueble derecha			
				 Ø3.5 x 12mm	
⑦		⑧		⑨	
x 1		x 1		x 12	
TWF4005					
 Ø4x 32mm		 Ø4.5 x 42mm		 30*30*30mm	
⑩ x 6		⑪ x 2		⑫ x 2	
Screw Tornillo TWF3176		Screw Tornillo TWF3174		ANGLE BRACKET Escuadra TWF0007	
				 Ø4 x 15	
⑬ x 2		⑭ x 2		⑮ x 24	
CASTER WITH LOCK Lanzador con cerradura TWF2715		CASTER Echador TWF2706		Screw Tornillo TWF3101	

PARTS -PIEZAS

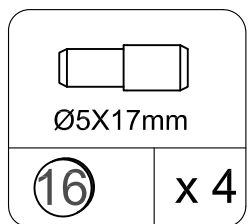

SHELF SUPPORT  
Soporte de repisa  
TWF3167

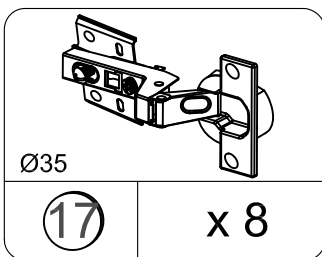

HINGE  
Bisagra  
TWF4201

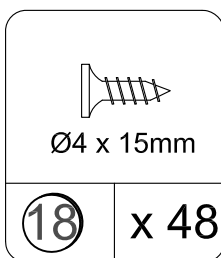

Screw  
Tornillo  
TWF3170

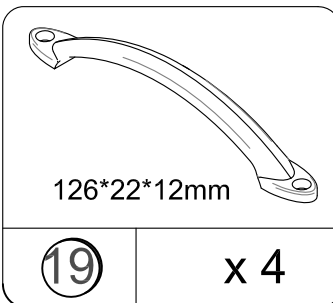

Handle  
Manija  
TWF4102

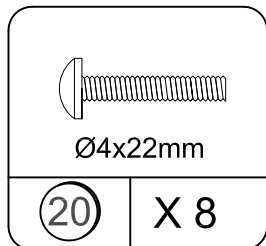

Bolt  
Perno  
TWF3106

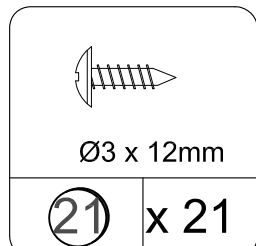

SCREW  
Tornillo  
TWF3104

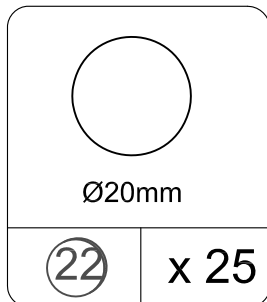

COVER  
Cubre  
TWF7031

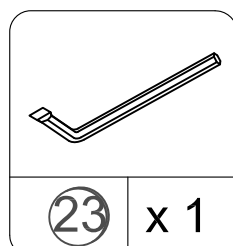

Hex Key  
Llave Hexagonal  
TWF3805

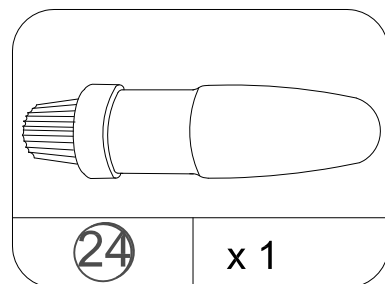

GLUE  
Pegamento  
TWF4901

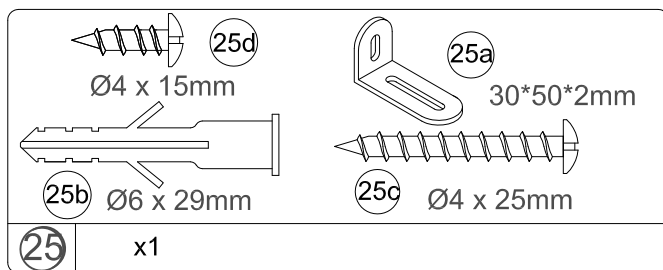

SAFETY STRAP KIT  
TWF0009

This illustration shows how the CAM fastening system works.

Esta ilustración muestra como funciona el sistema de fijación de leva.

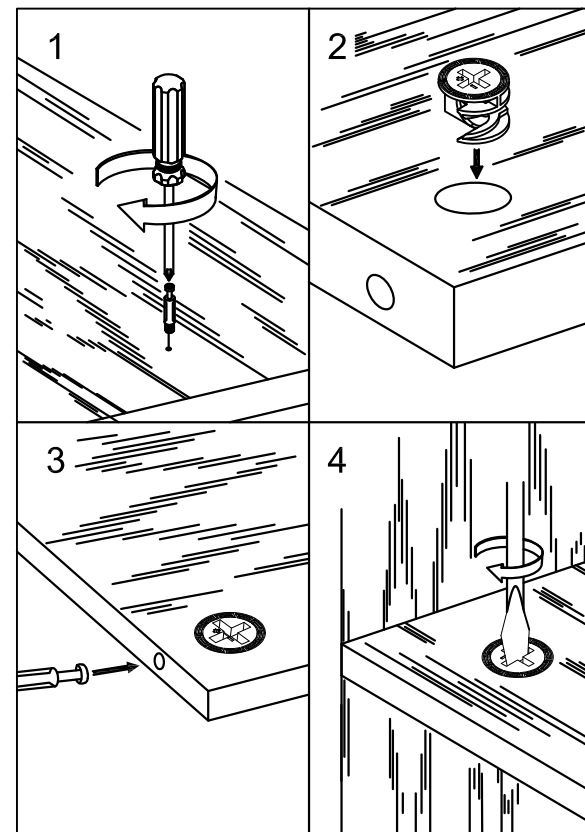

To view a video on how the CAM fastening system works, download a free QR-reader on your smartphone, then scan the code.

Para ver un video de como funciona el sistema de sujeción CAM, descargue una aplicación gratis que podrá ver en su teléfono móvil, entonces escanee el código.



# 1

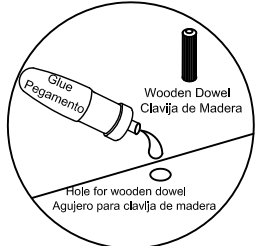
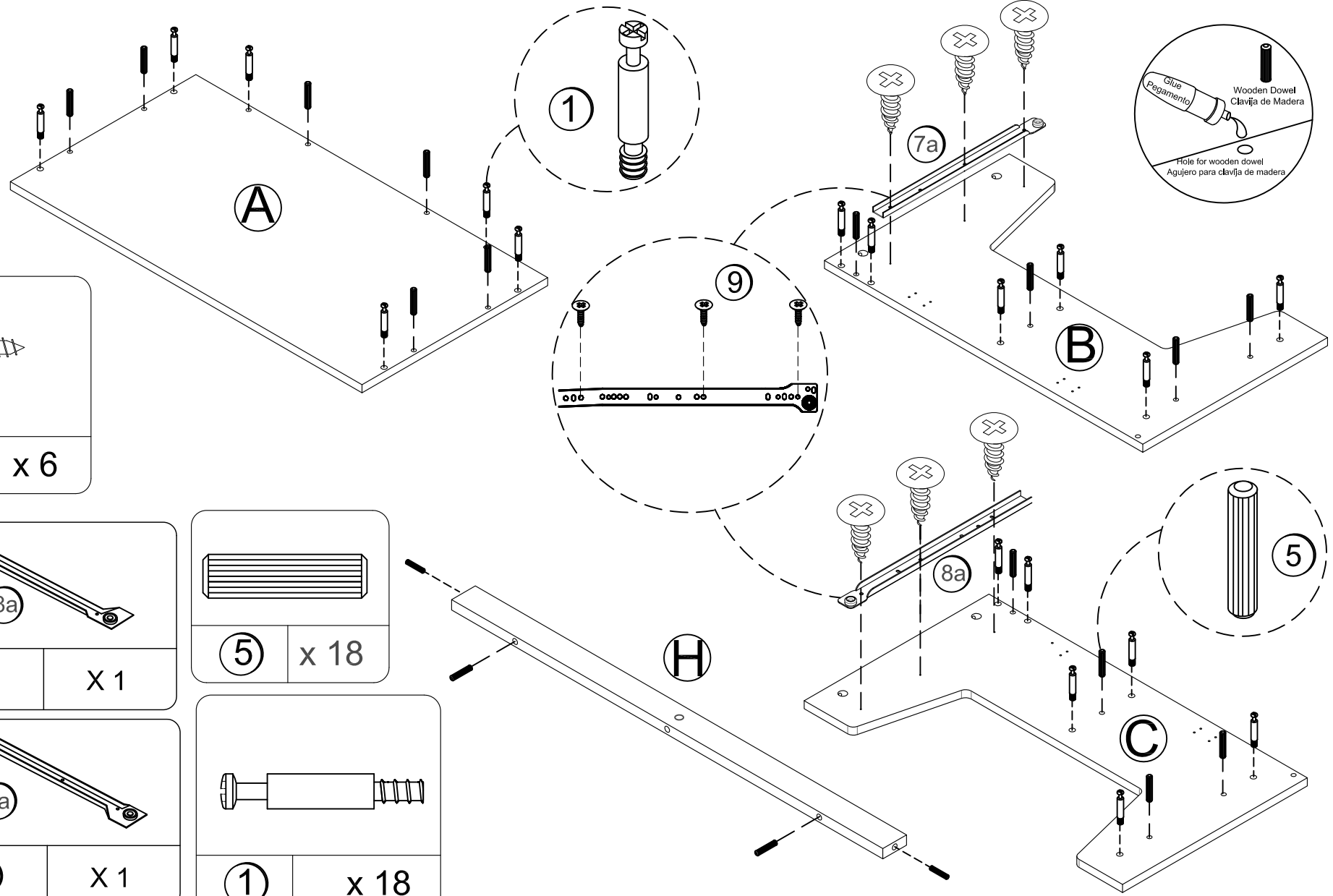

9 x 6

8a

8 x 1

5 x 18

7a

7 x 1

1 x 18



# 3

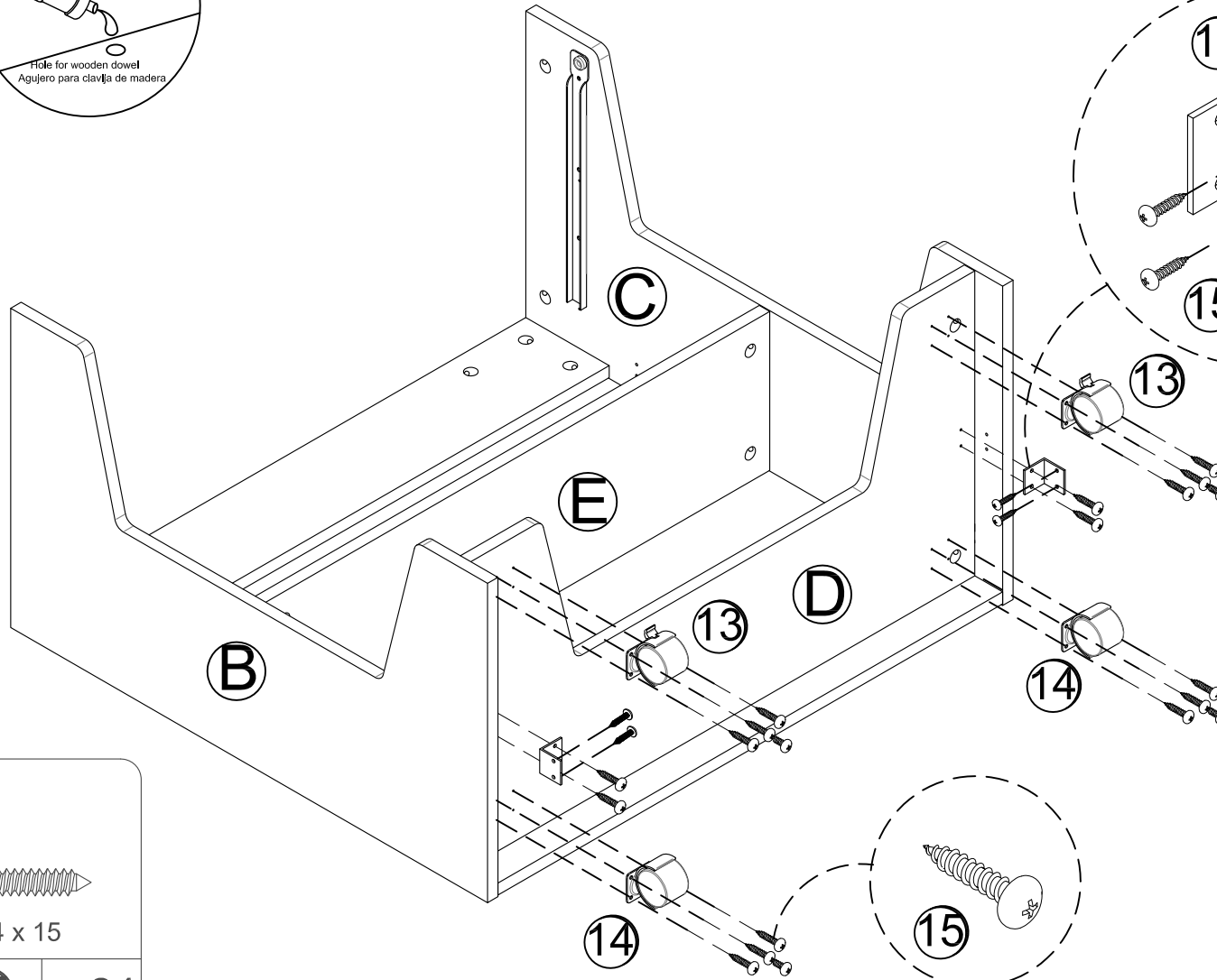
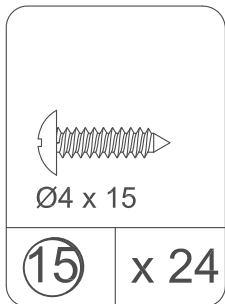
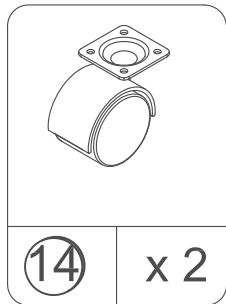
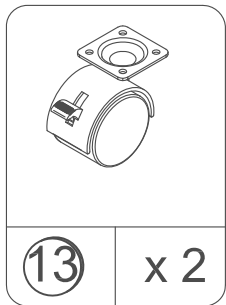
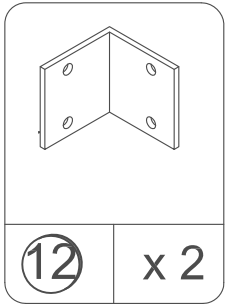
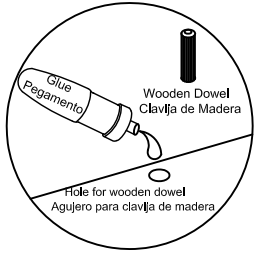

# 4

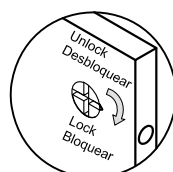
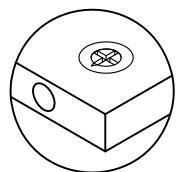

Proper orientation of cam lock  
La orientación apropiada para el seguro de bloqueo

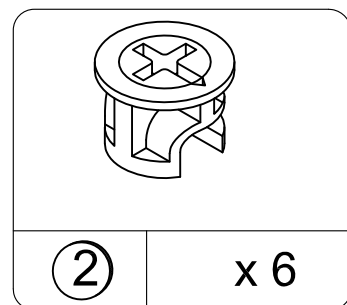
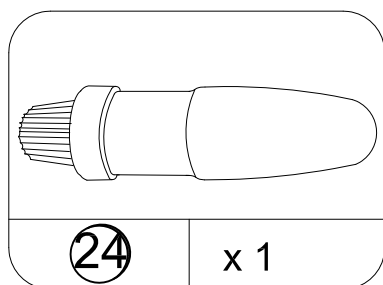
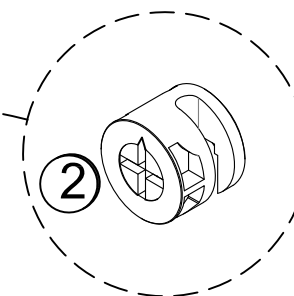
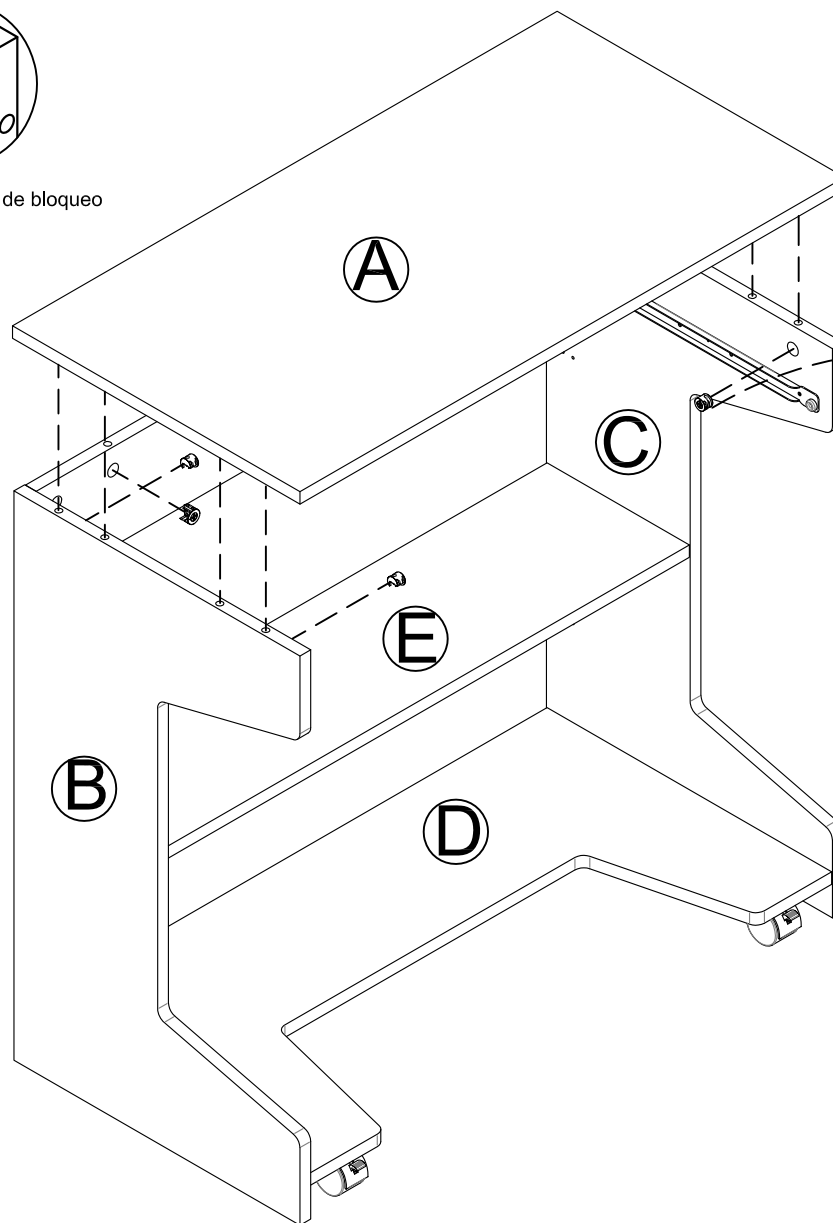
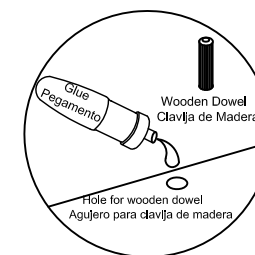

# 5

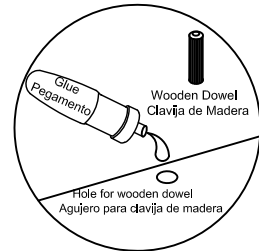
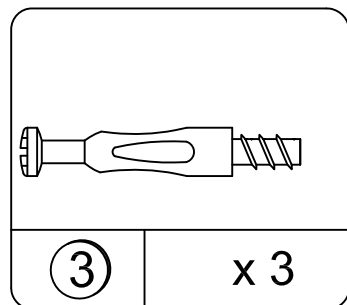
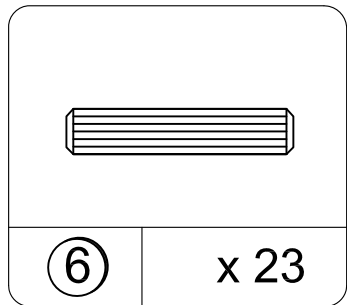
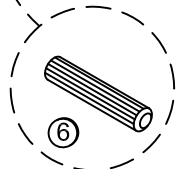
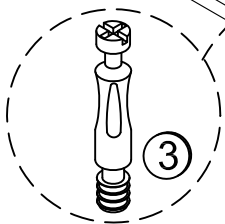
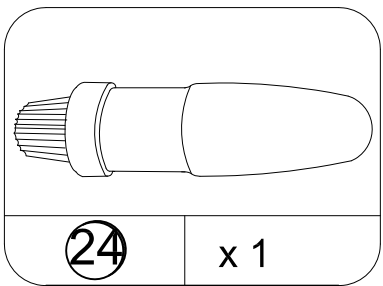
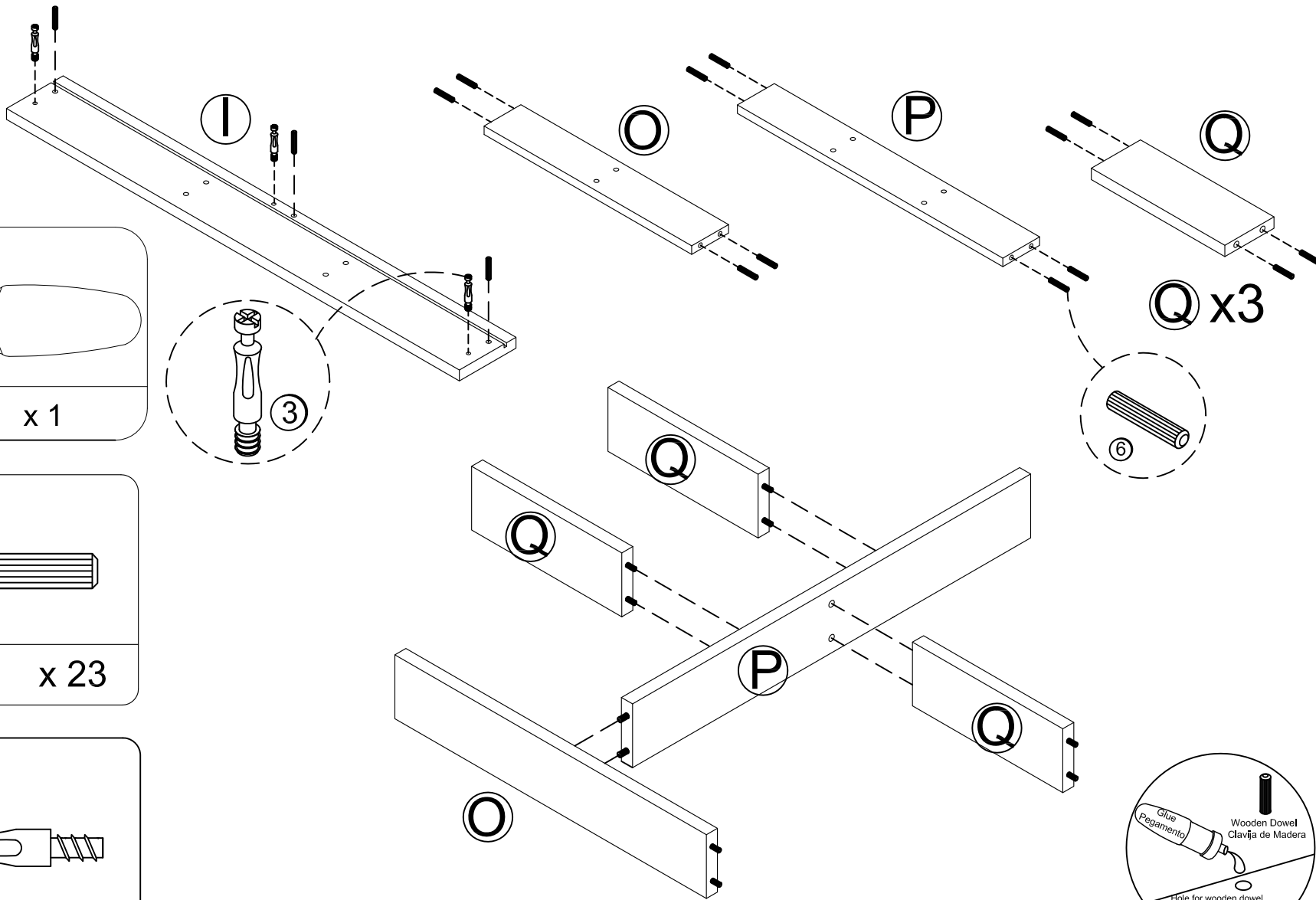

# 6

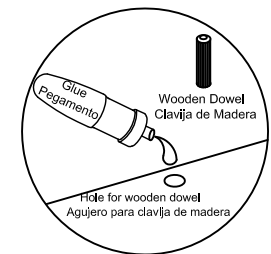
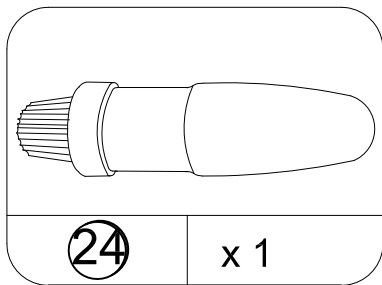
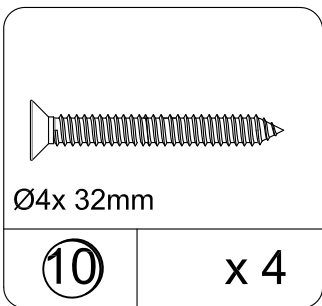
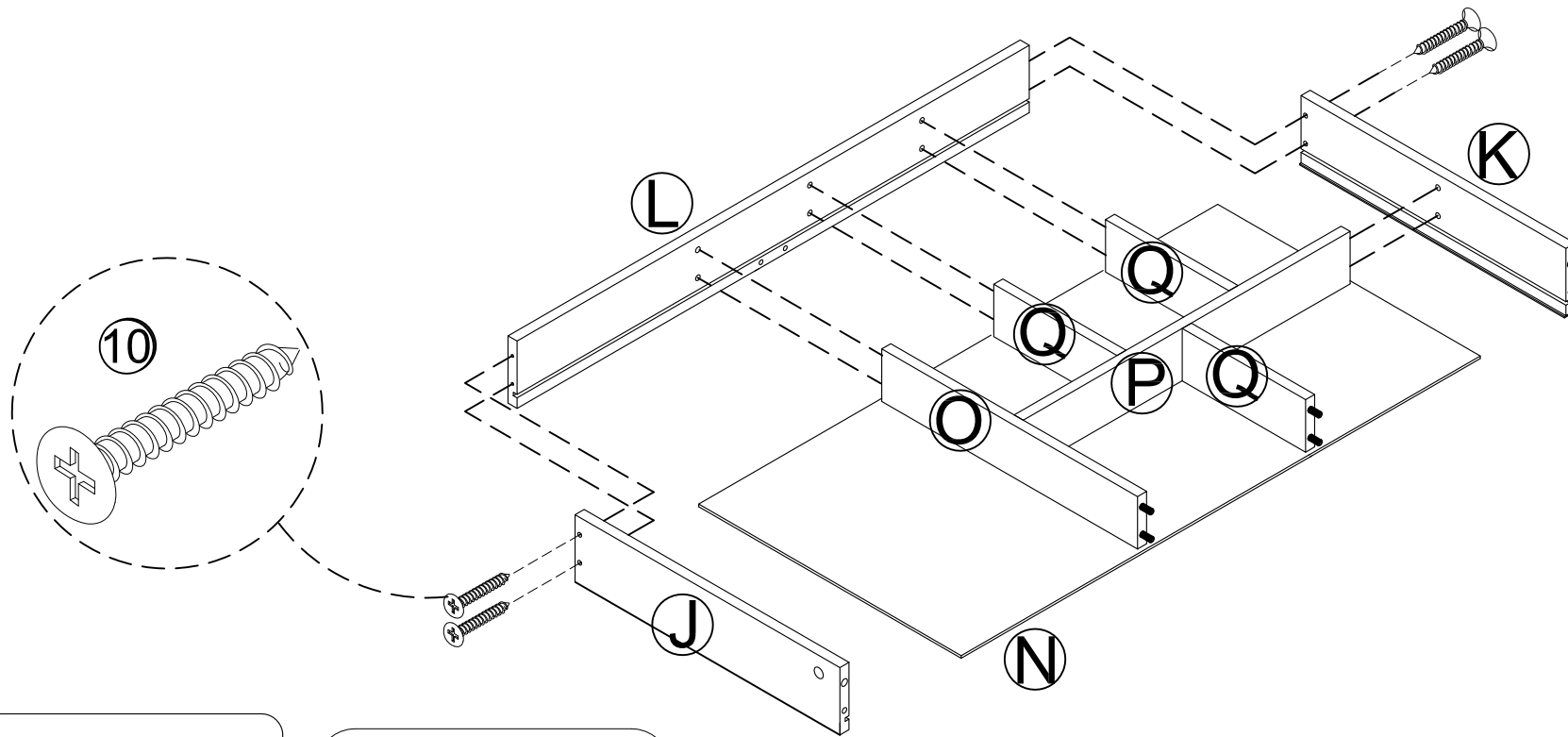

# 7

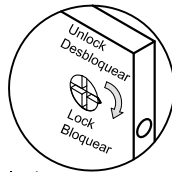
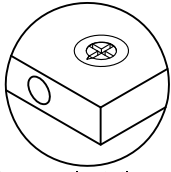

Proper orientation of cam lock  
La orientación apropiada para el seguro de bloqueo

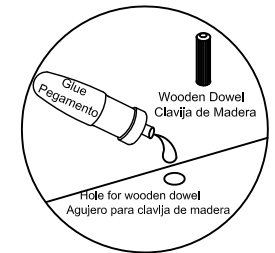
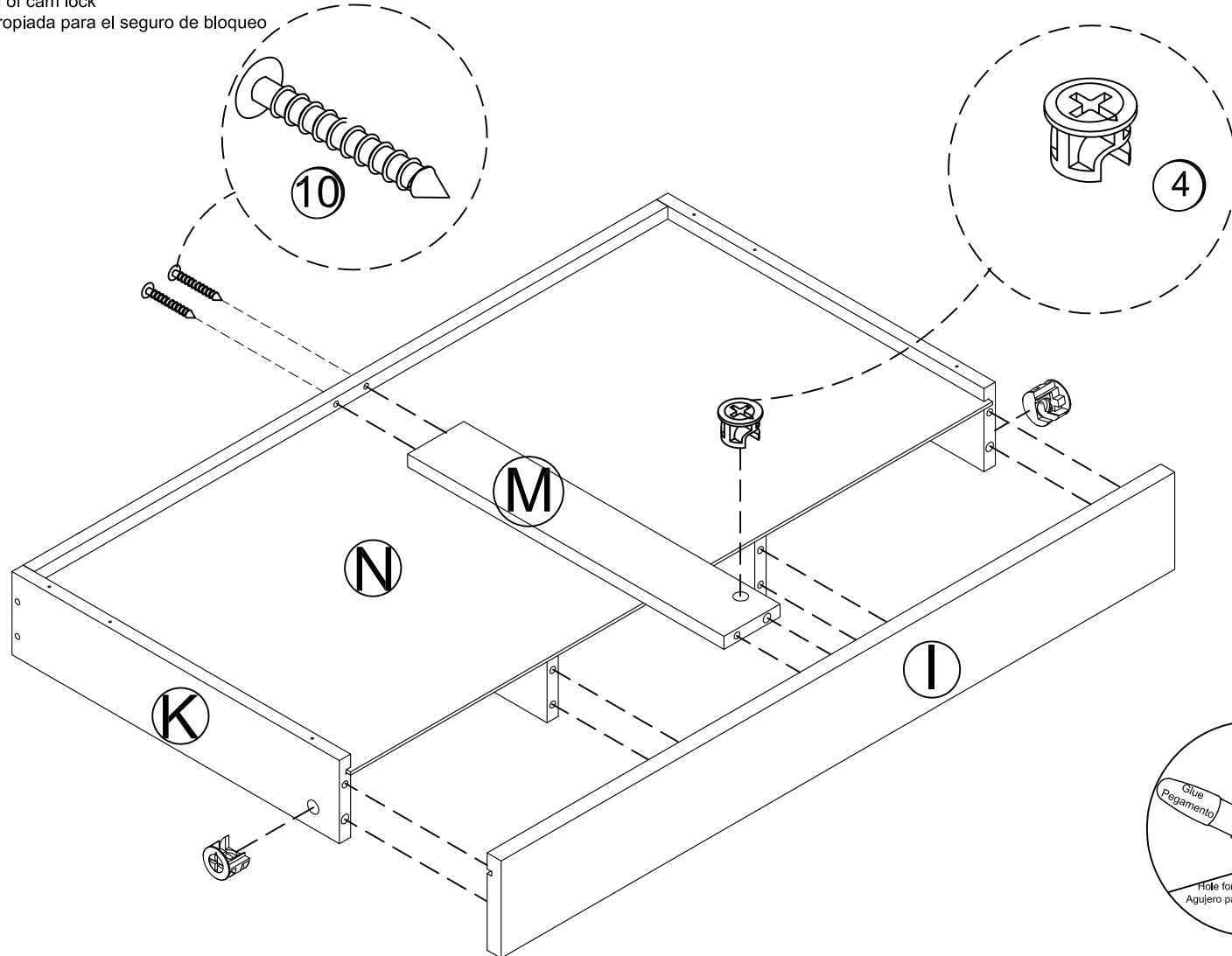
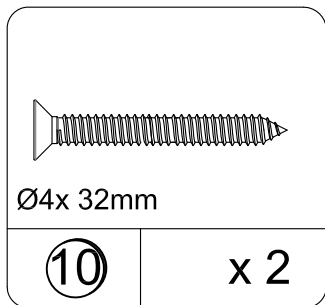
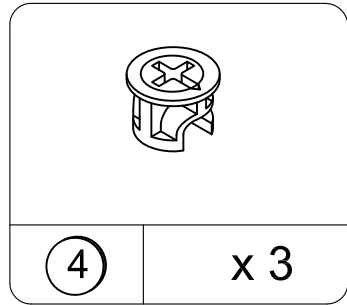
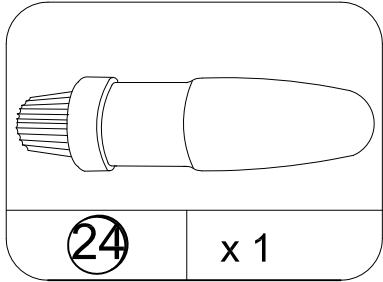

# 8

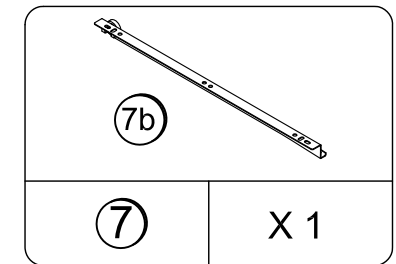
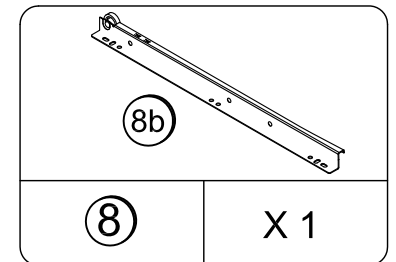
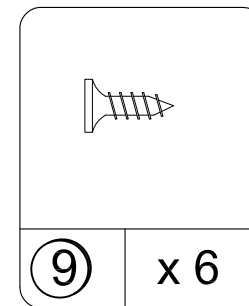
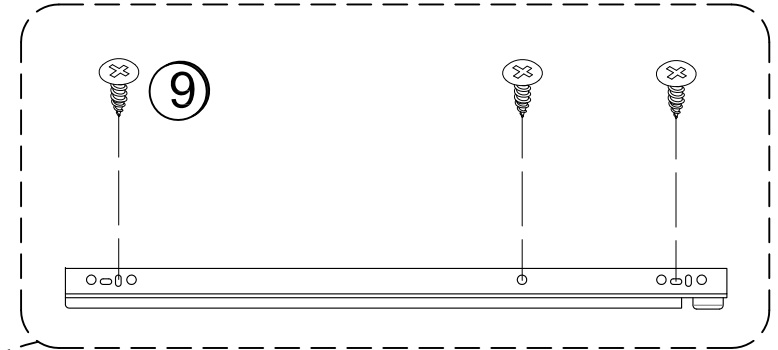
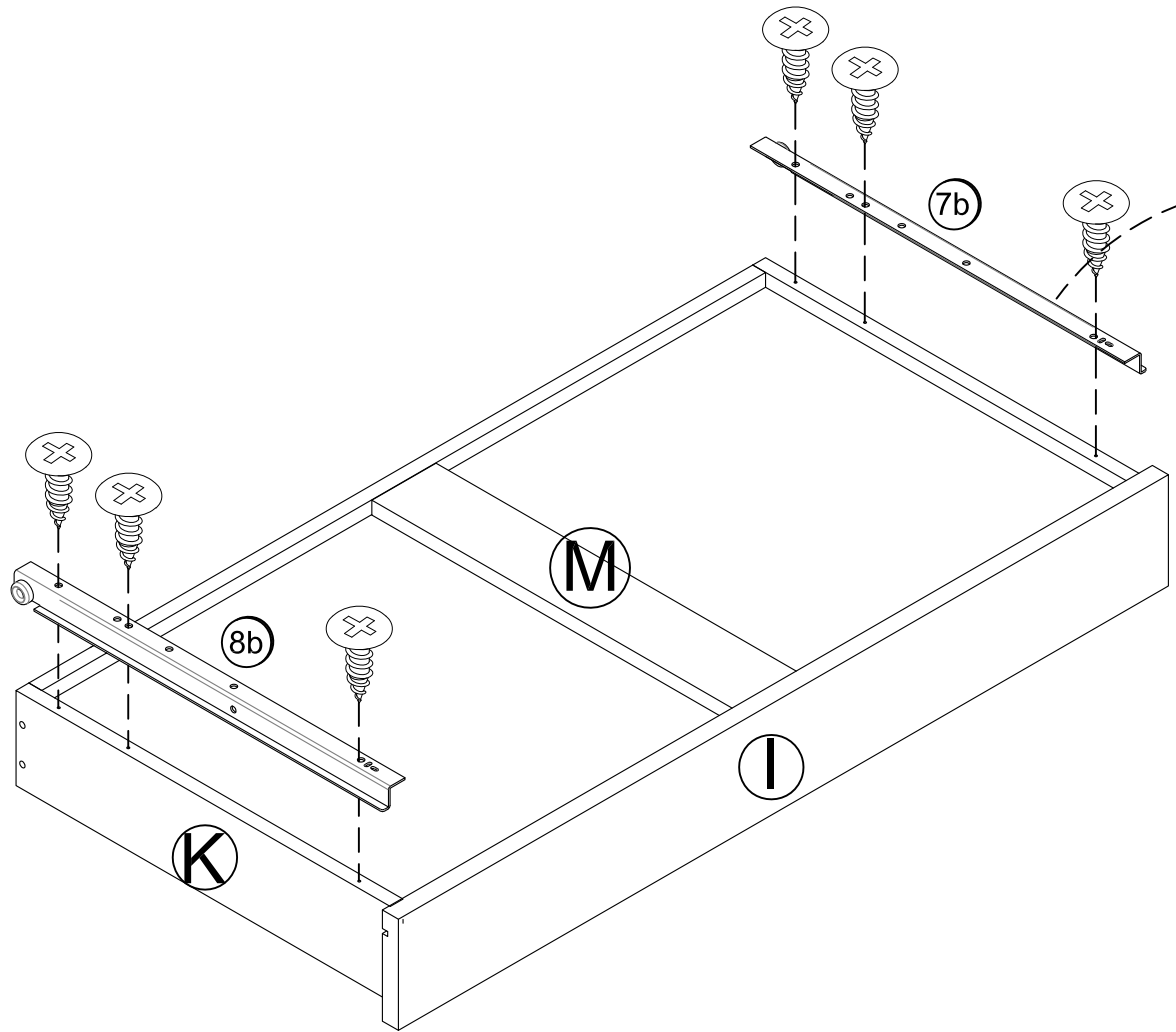



9

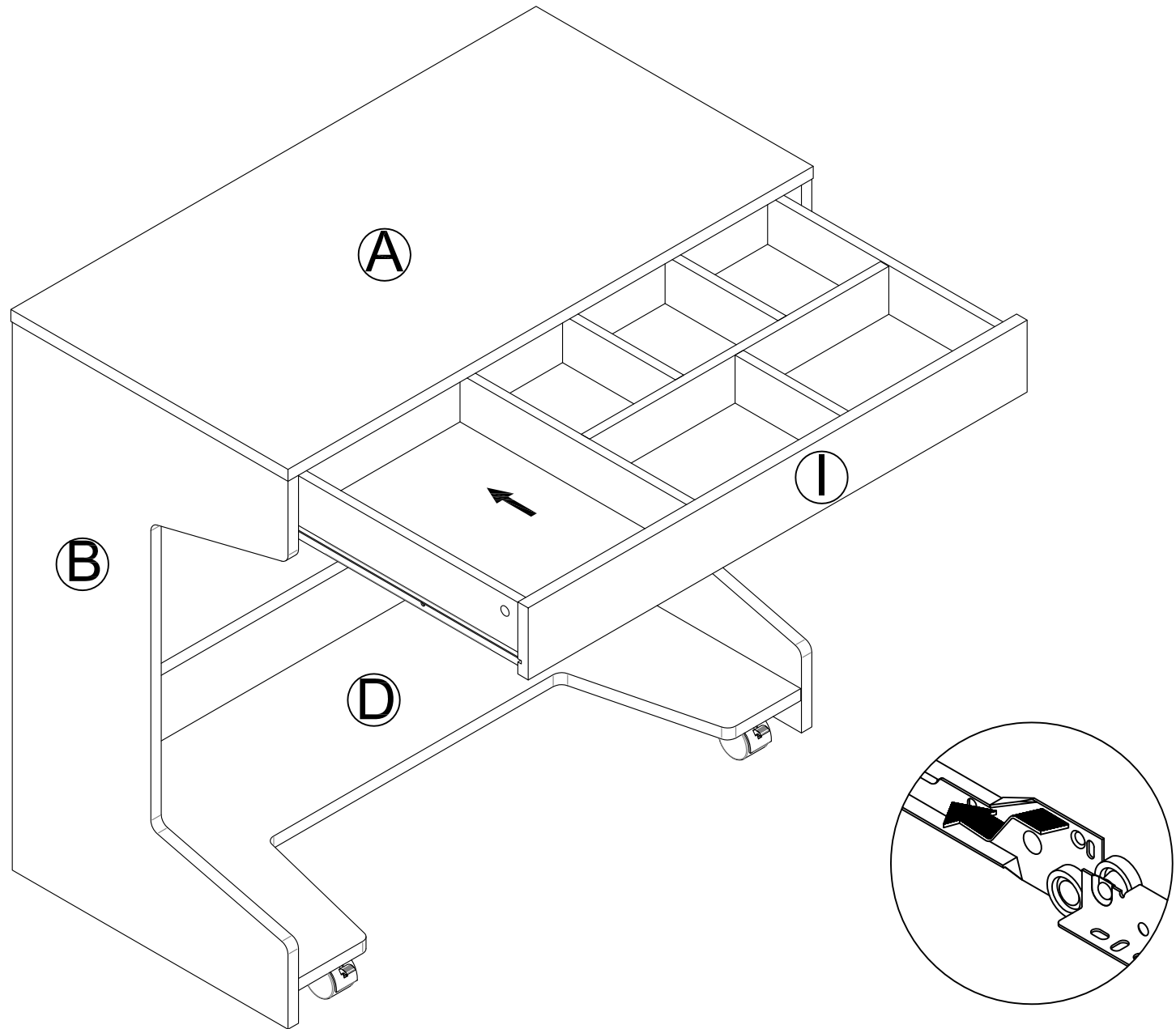

# 10

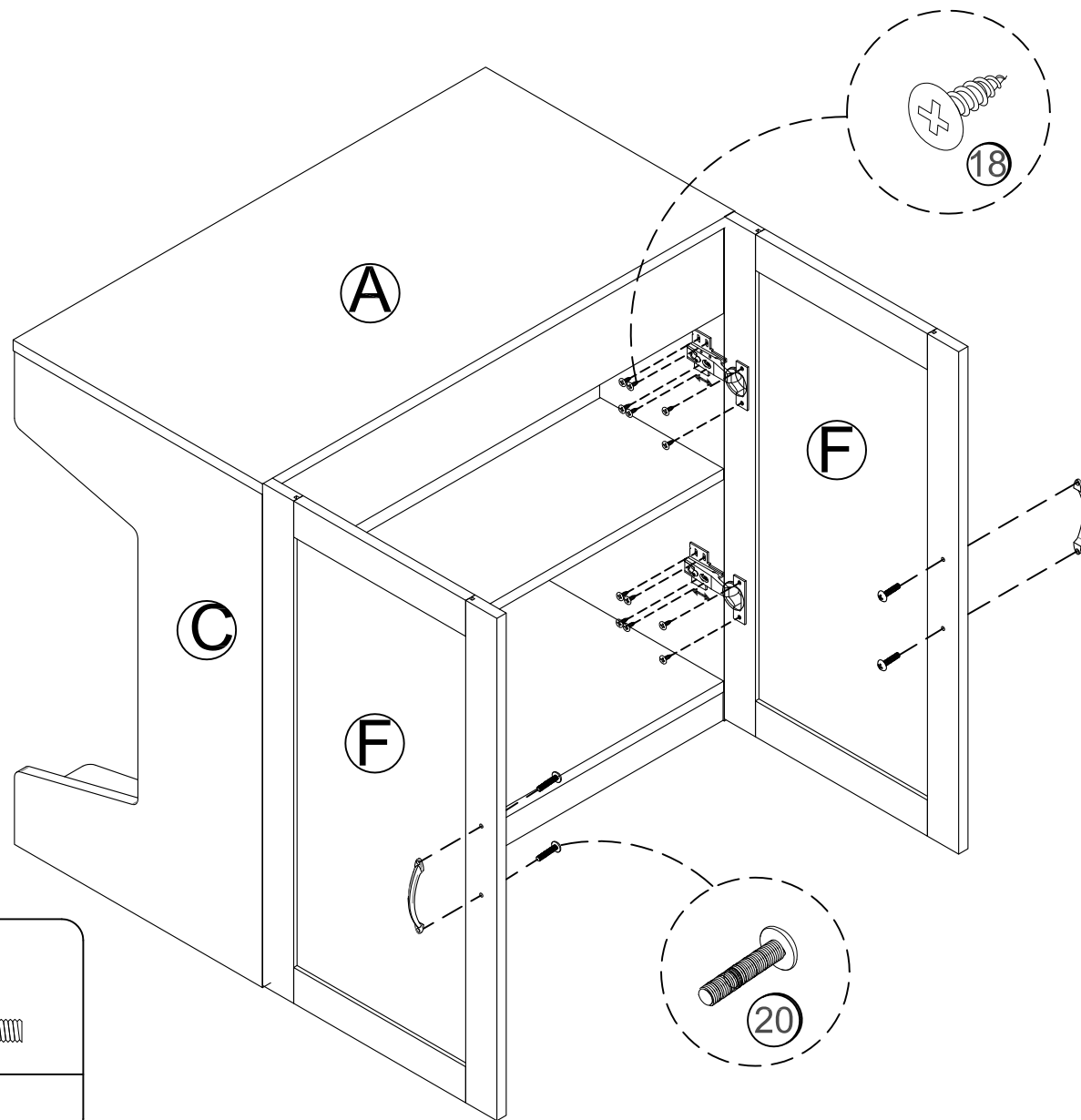
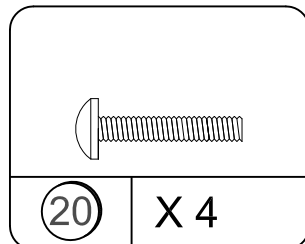
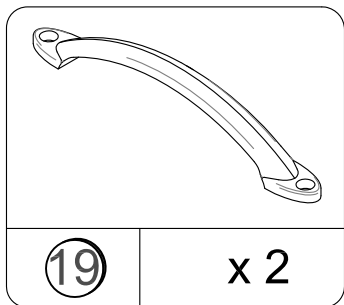
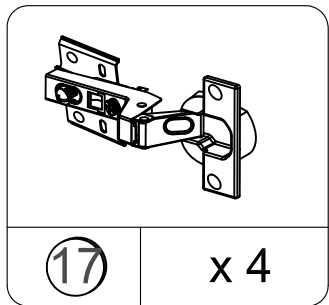
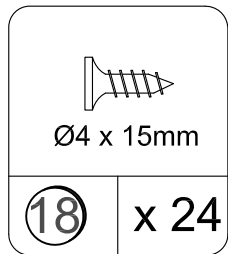

# 11

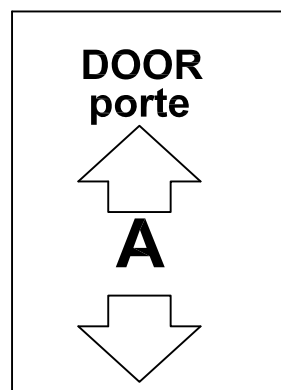

**FRONT VIEW**  
vue de face

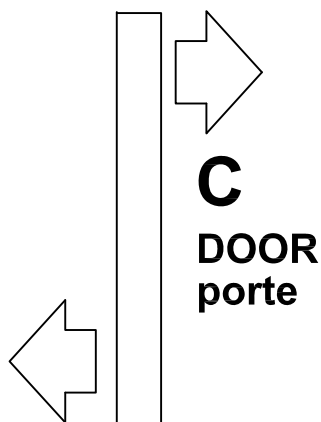

**SIDE VIEW**  
vue de côté

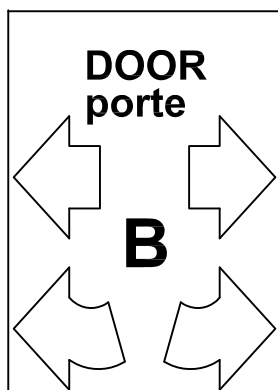
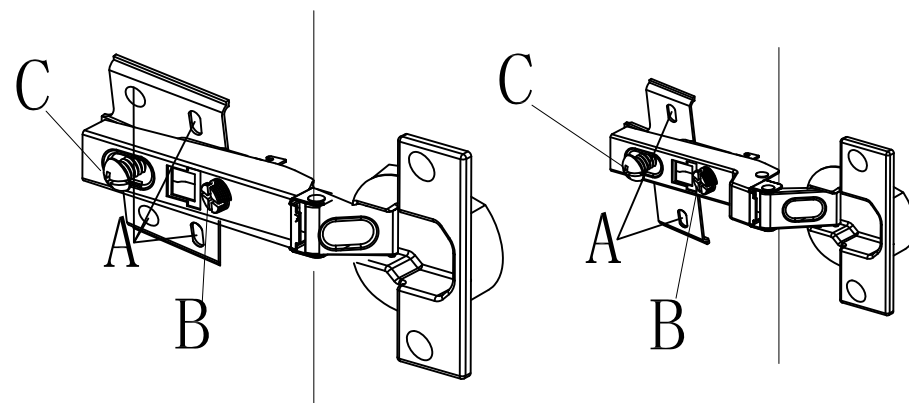

**FRONT VIEW**  
vue de face

To adjust doors:"A"  
Loosen "A" screws.  
Adjust door.  
Tighten "A" screws.

Pour ajuster les portes: "A"  
Desserrez les vis "A".  
Ajustez la porte.  
Serrez les vis "A".

To adjust doors:"B"  
Loosen "C" screw.  
Turn "B" to move door.  
Tighten "C" screws.

Pour ajuster les portes: "B"  
Desserrez la vis "C".  
Tournez la vis "B" pour déplacer  
la porte  
Serrez la vis "C".

To adjust doors:"C"  
Loosen "C" screws.  
Adjust door.  
Tighten "C" screws.

Pour ajuster les portes: "C"  
Desserrez la vis "C".  
Ajustez la porte.  
Serrez la vis "C".



# 13

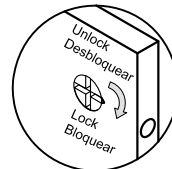
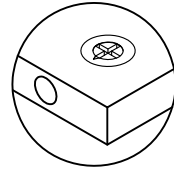

Proper orientation of cam lock  
La orientación apropiada para el seguro de bloqueo

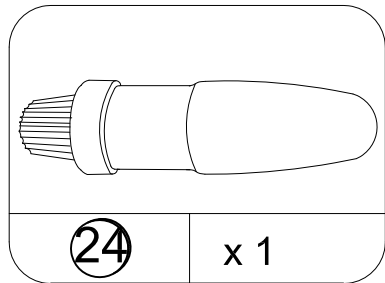
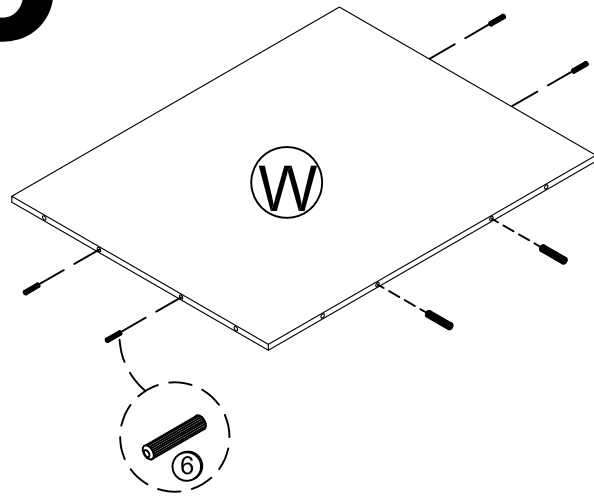
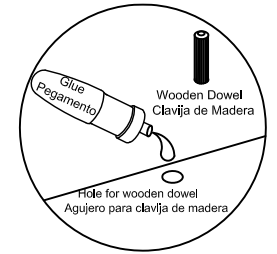

24

x 1

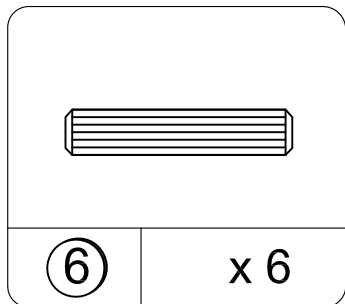

6

x 6

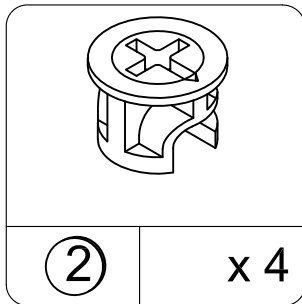

2

x 4

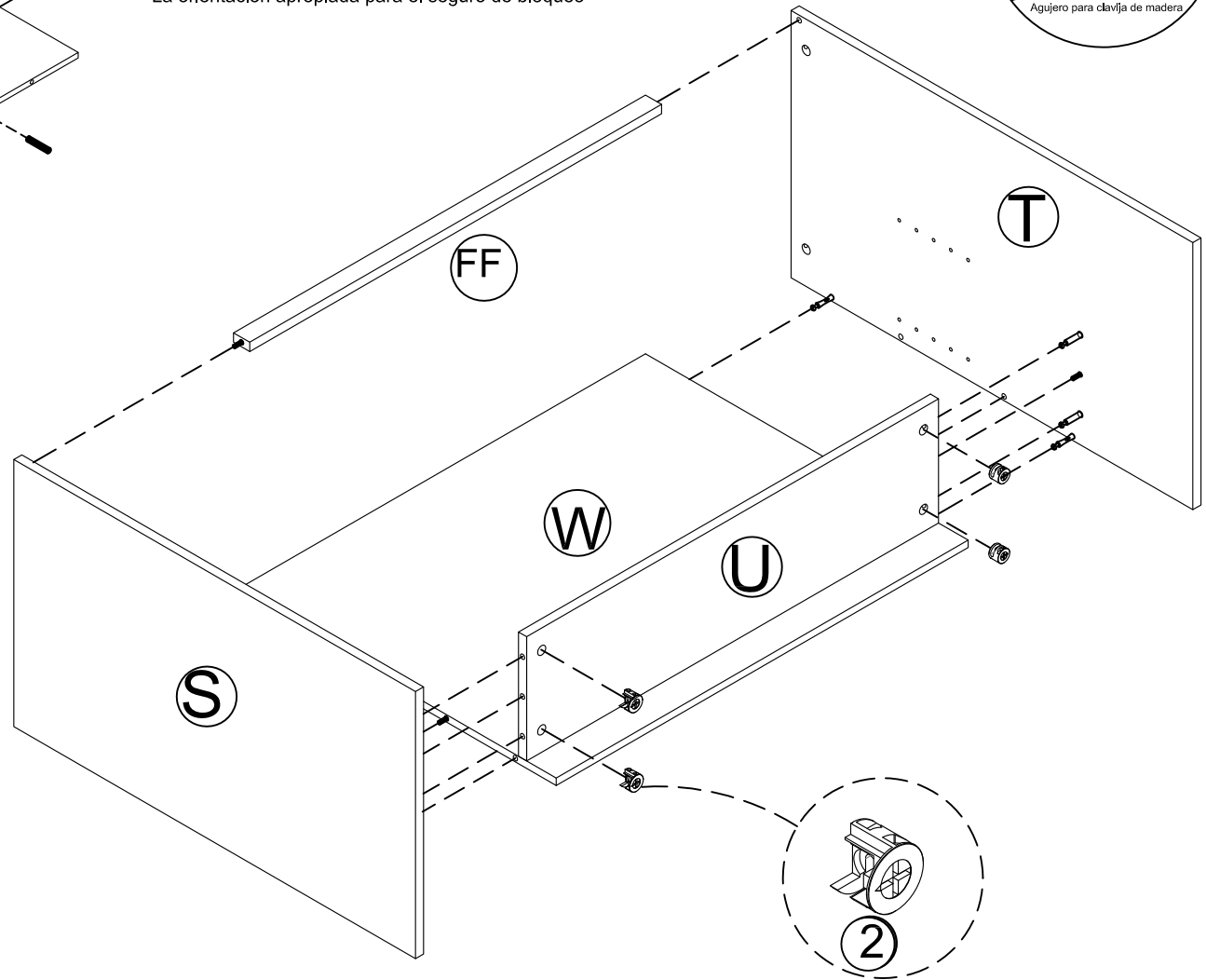

# 14

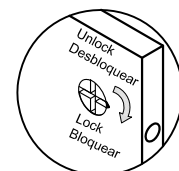
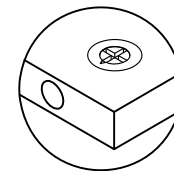
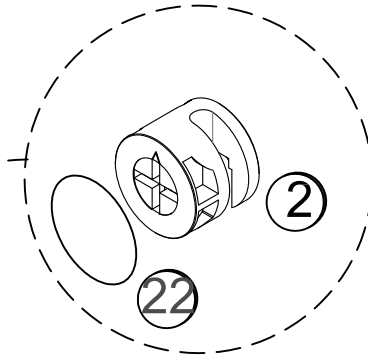
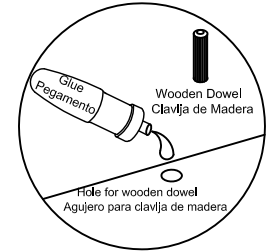
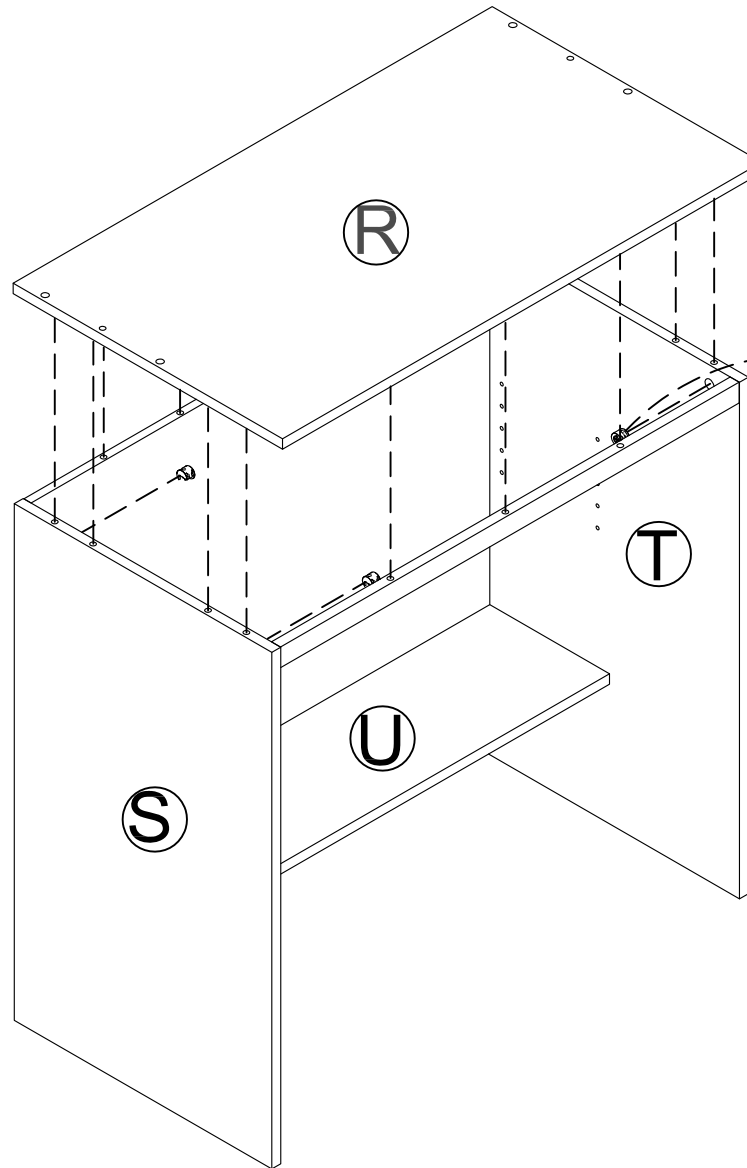
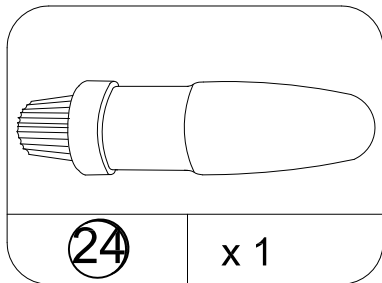
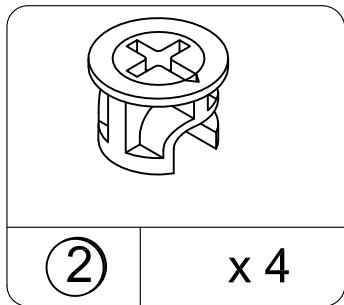
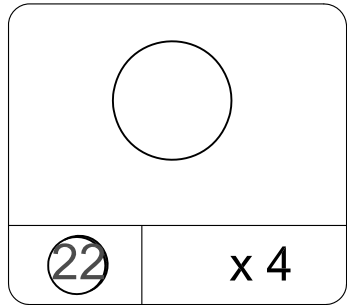

Proper orientation of cam lock  
La orientación apropiada para el seguro de bloqueo

# 15

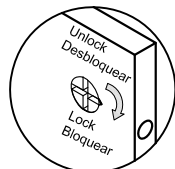
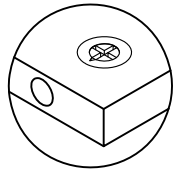

Proper orientation of cam lock  
La orientación apropiada para el seguro de bloqueo

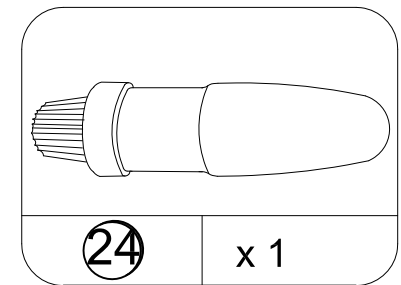
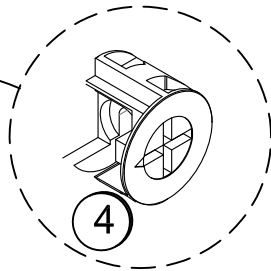
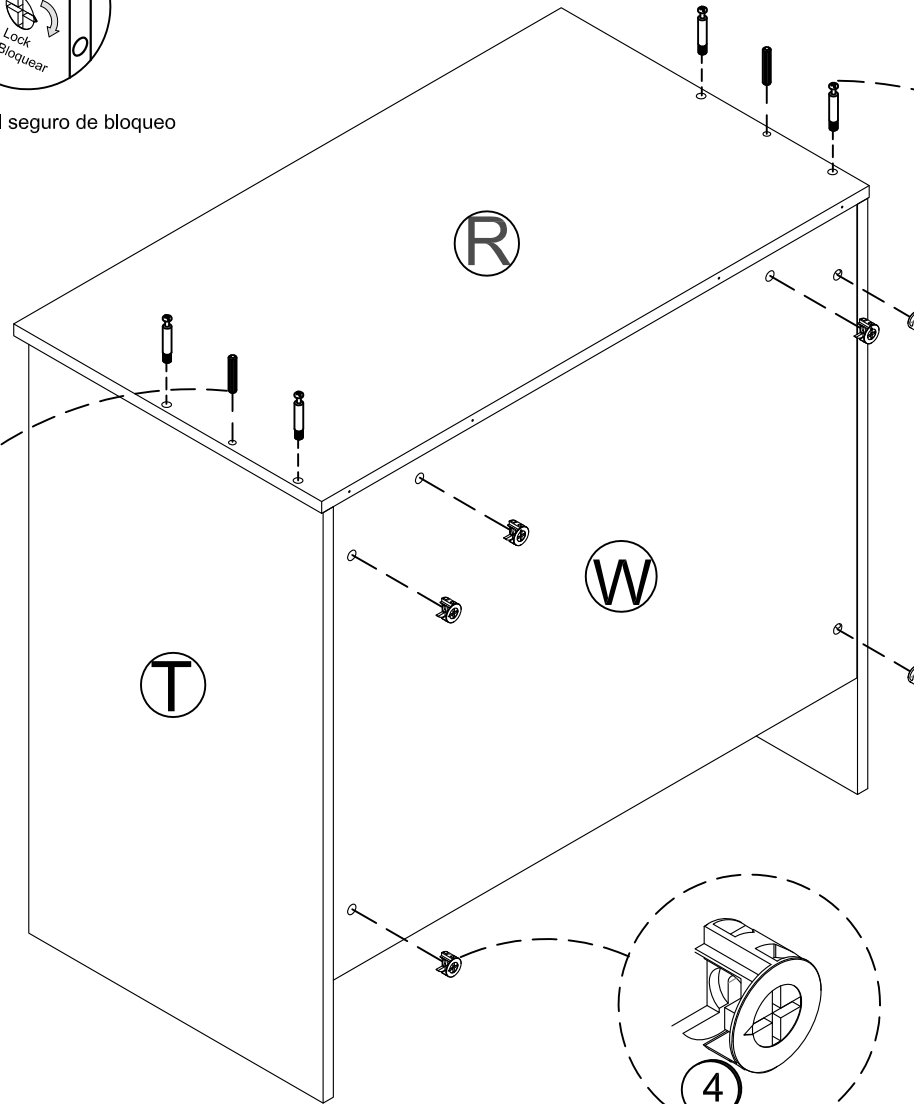
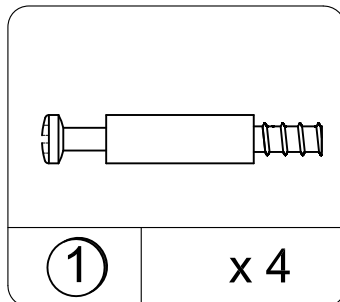
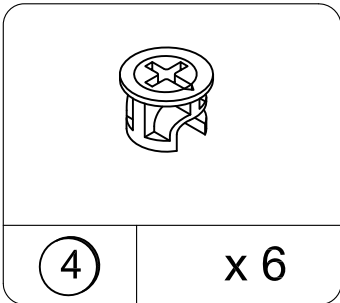
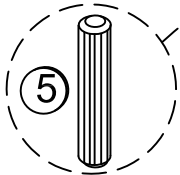
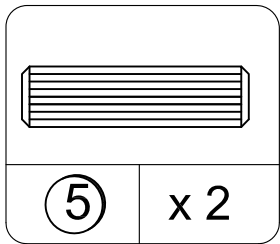
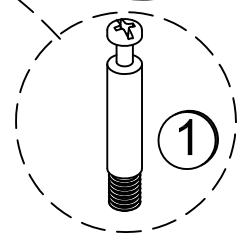
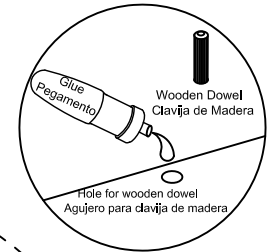

# 16

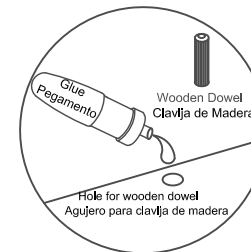
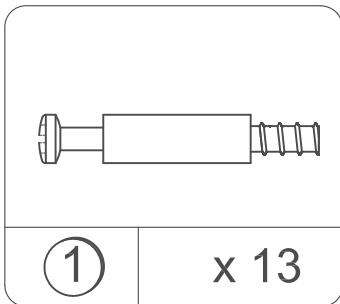
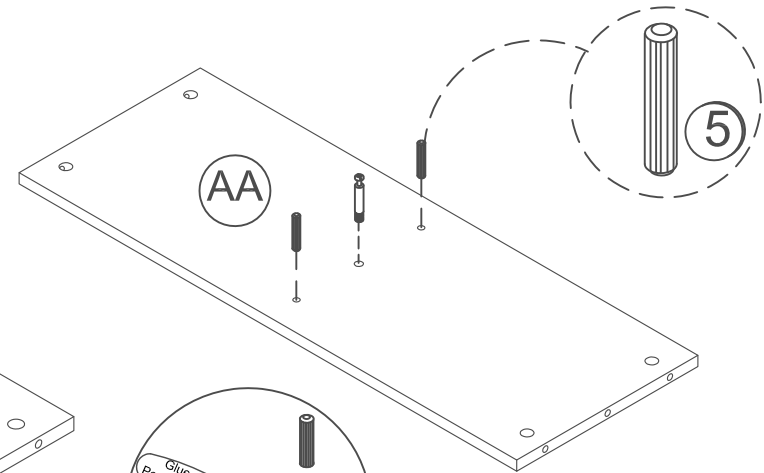
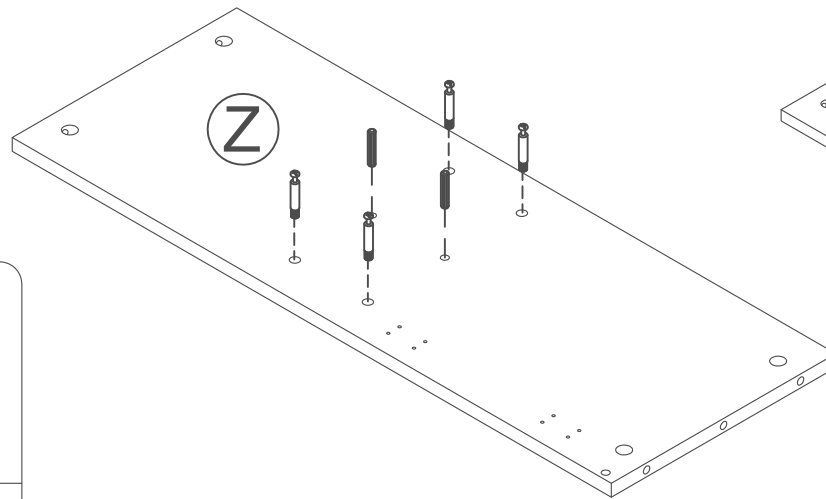
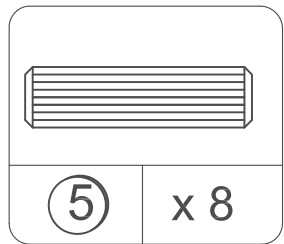
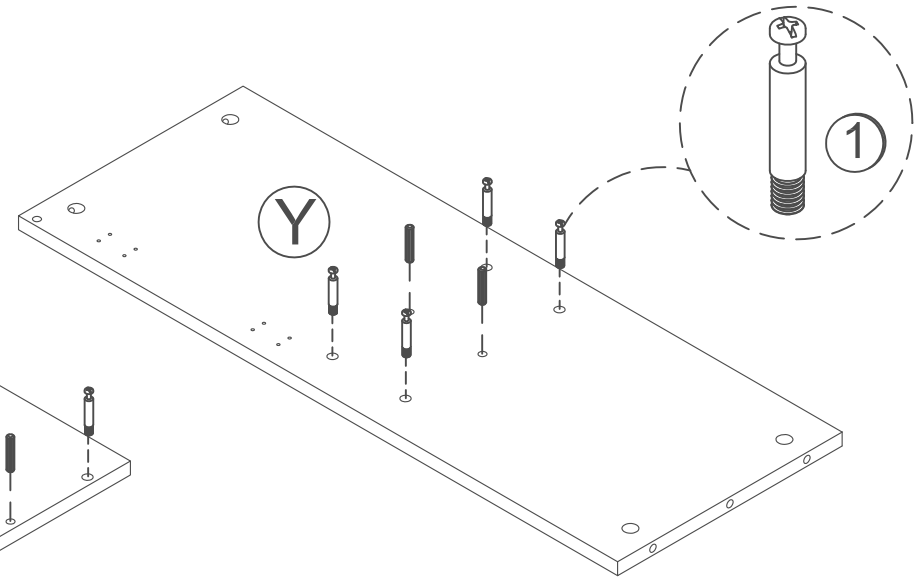
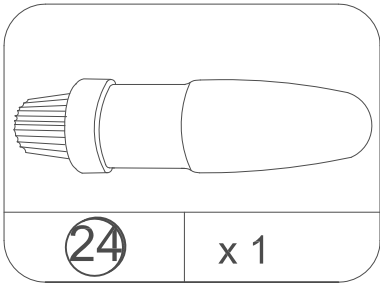
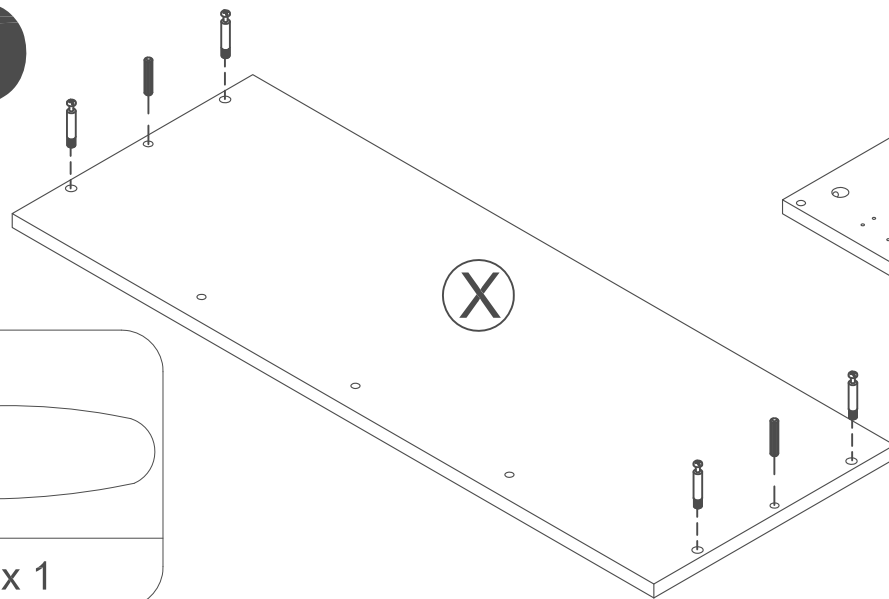



# 17

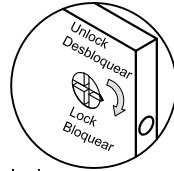
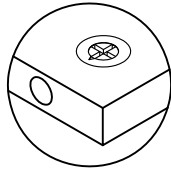
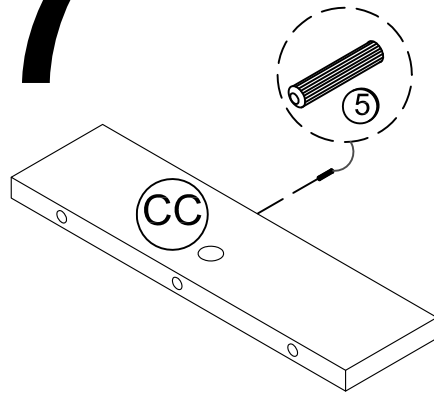

Proper orientation of cam lock  
La orientación apropiada para el seguro de bloqueo

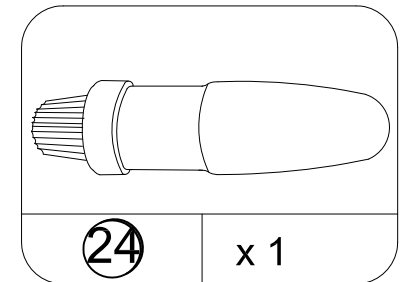
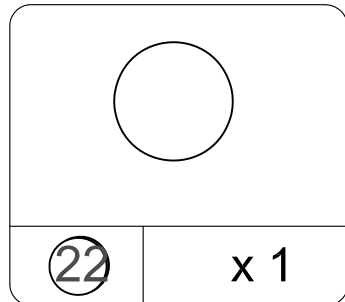
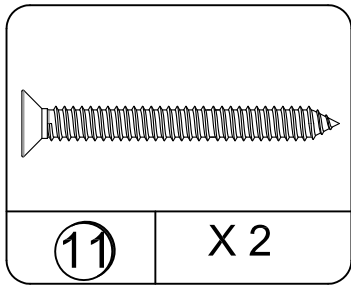
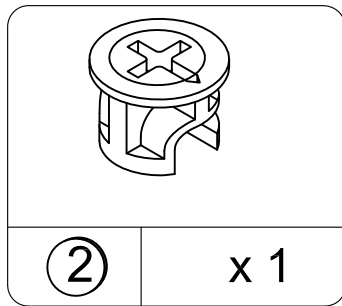
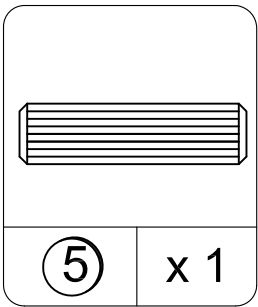
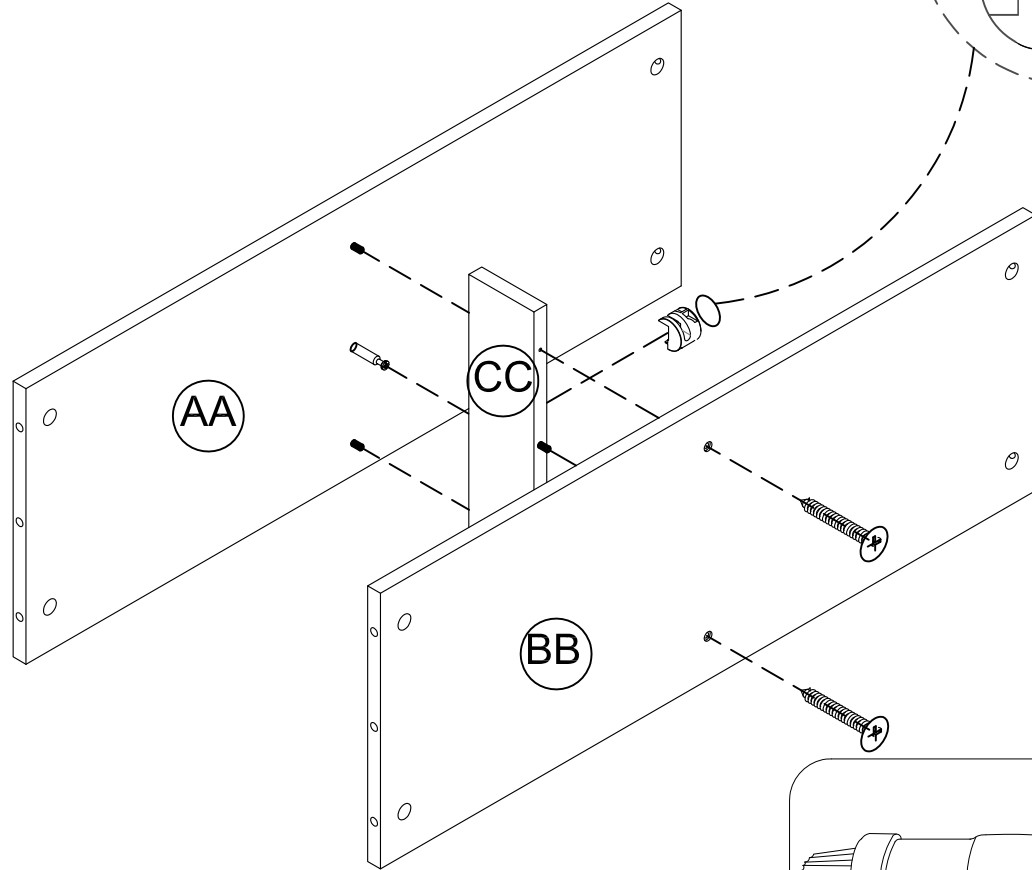
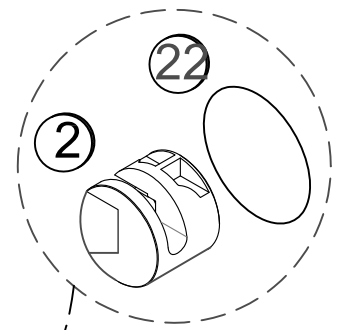
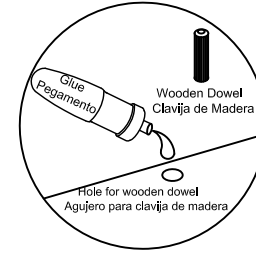

# 18

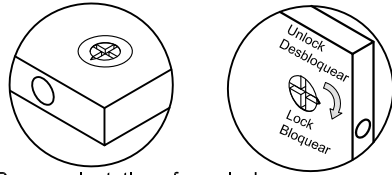

Proper orientation of cam lock  
La orientación apropiada para el seguro de bloqueo

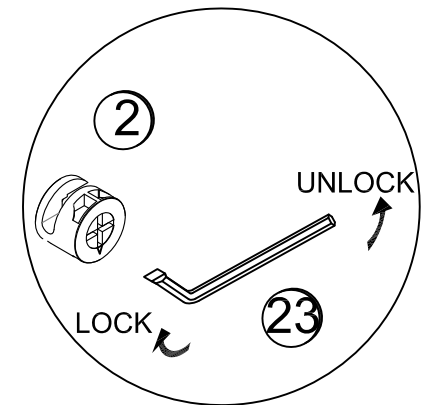
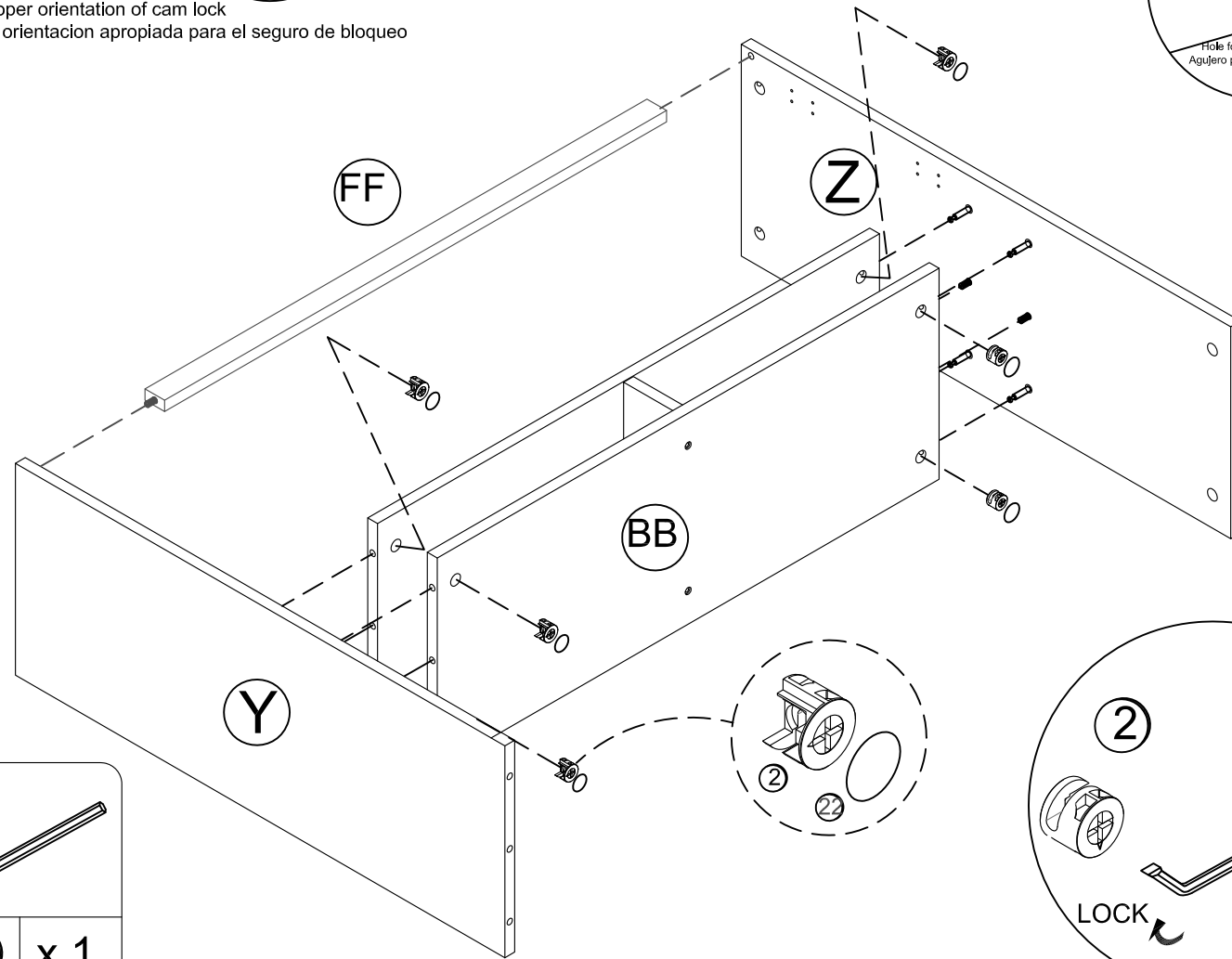
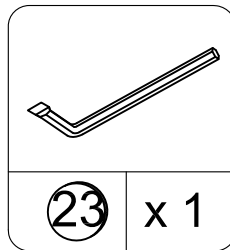
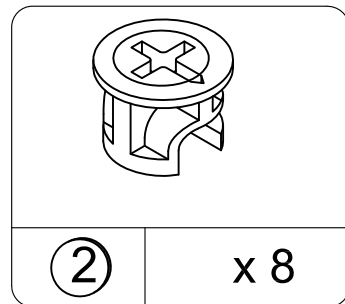
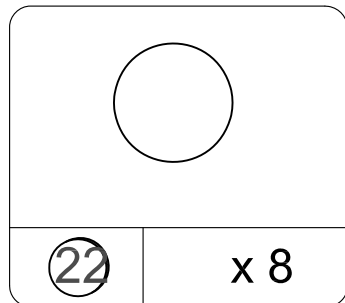
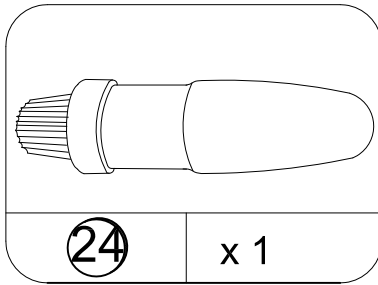
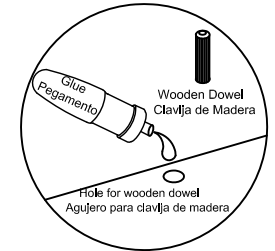

# 19

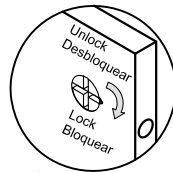
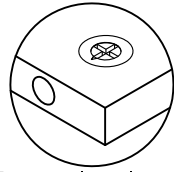

Proper orientation of cam lock  
La orientación apropiada para el seguro de bloqueo

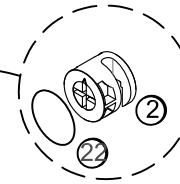
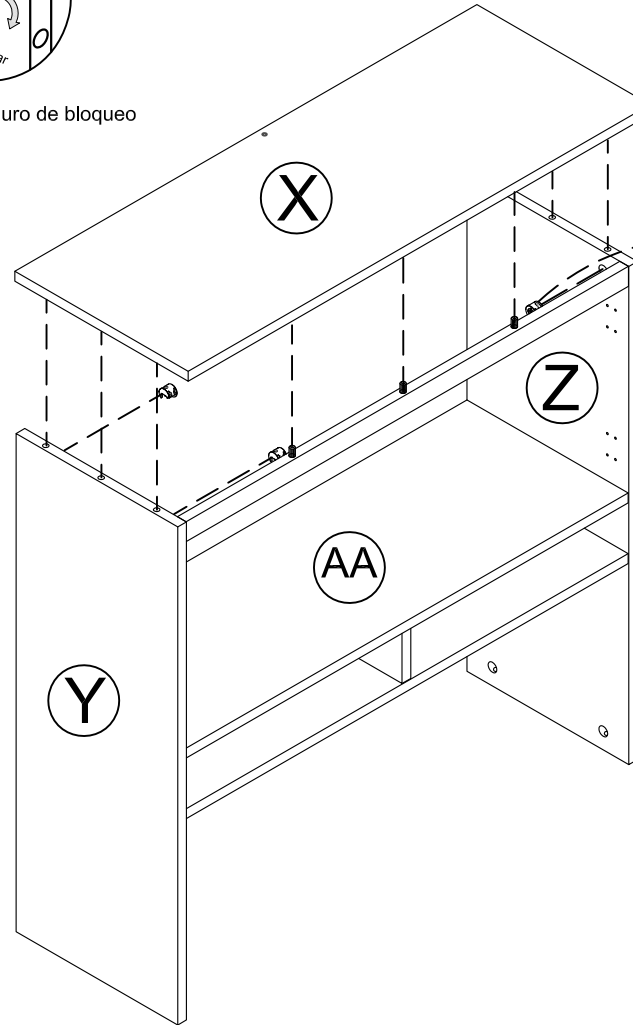
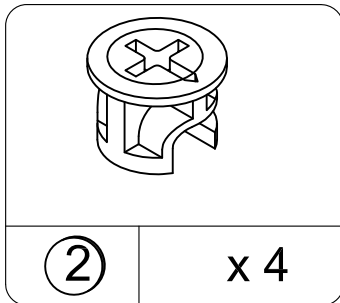
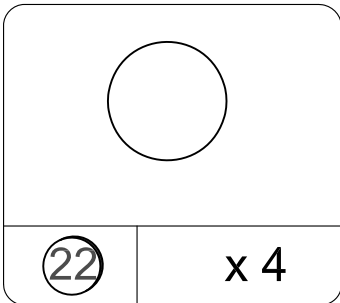
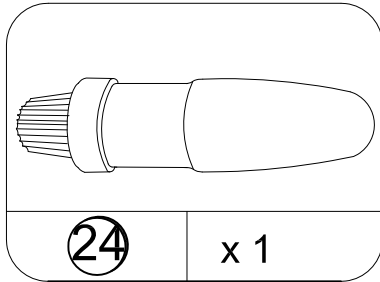
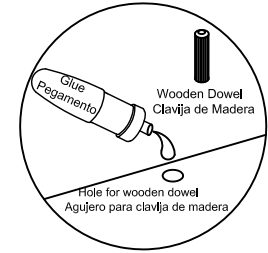

# 20

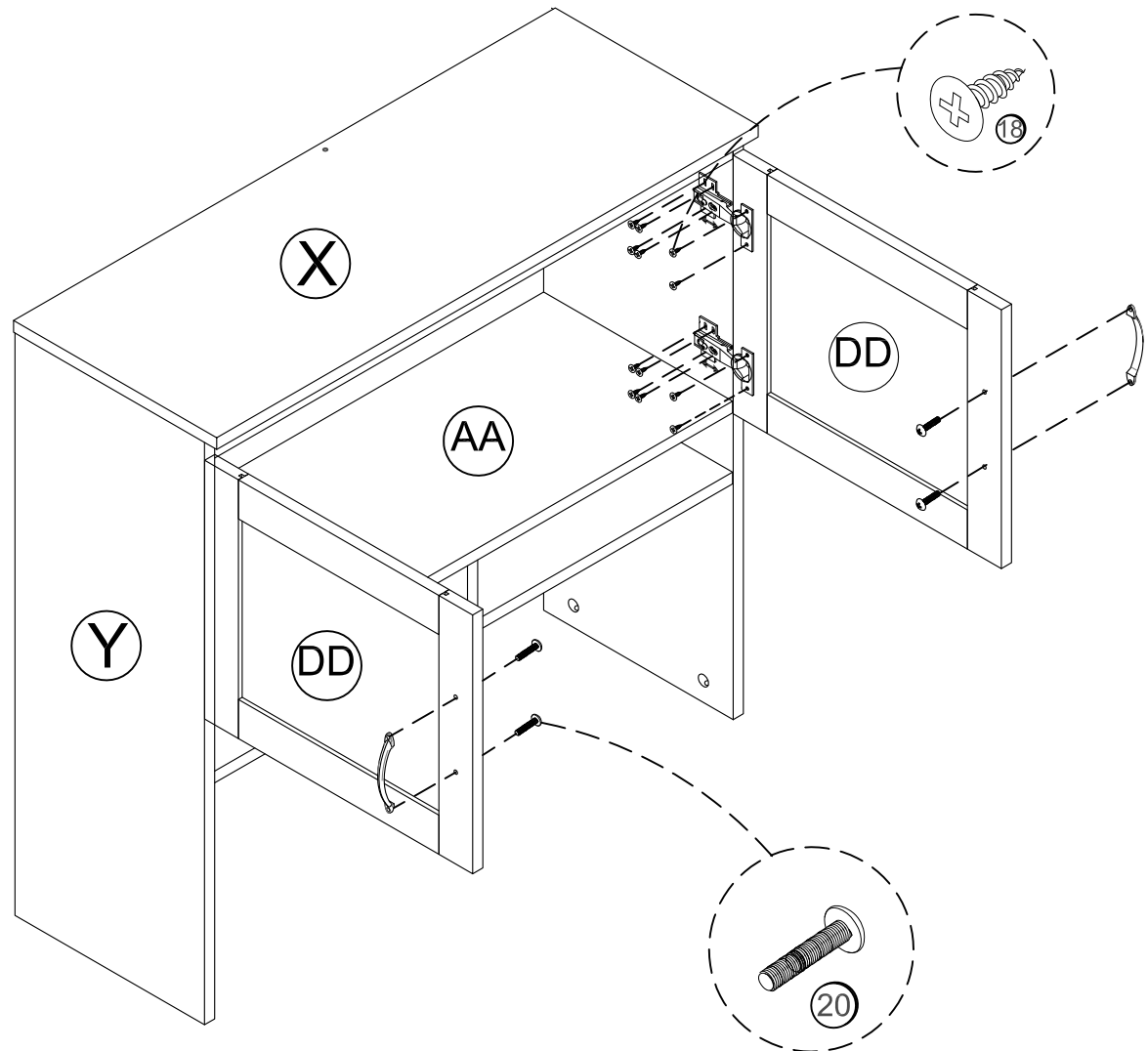
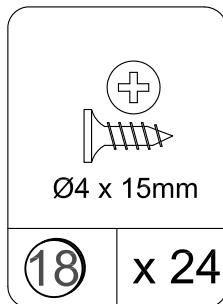
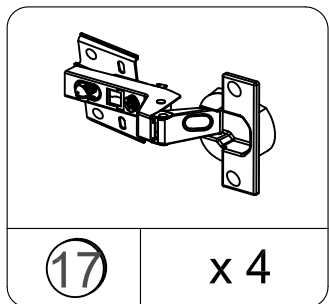
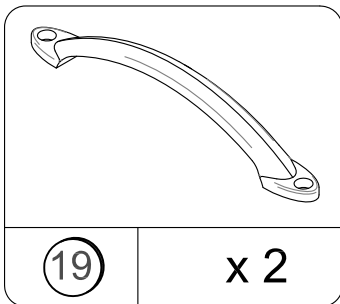
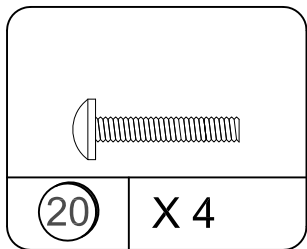

# 21

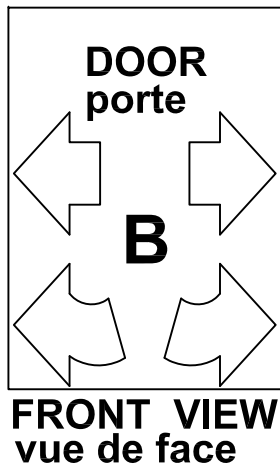
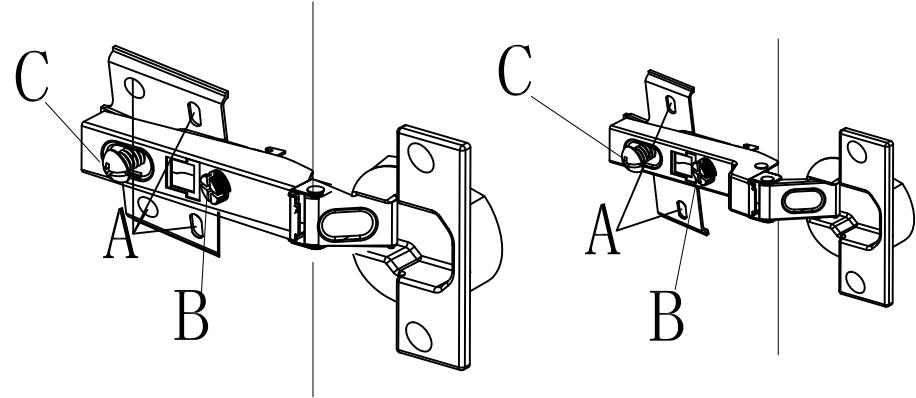
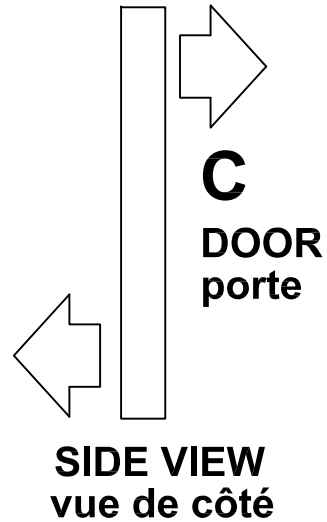
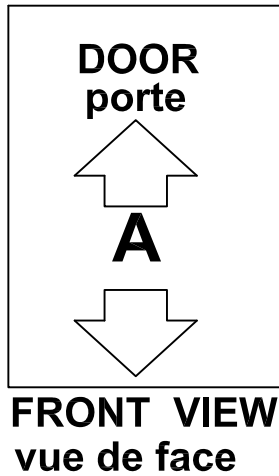

To adjust doors:"A"  
Loosen "A" screws.  
Adjust door.  
Tighten "A" screws.

Pour ajuster les portes: "A"  
Desserrez les vis "A".  
Ajustez la porte.  
Serrez les vis "A".

To adjust doors:"B"  
Loosen "C" screw.  
Turn "B" to move door.  
Tighten "C" screws.

Pour ajuster les portes: "B"  
Desserrez la vis "C".  
Tournez la vis "B" pour déplacer  
la porte  
Serrez la vis "C".

To adjust doors:"C"  
Loosen "C" screws.  
Adjust door.  
Tighten "C" screws.

Pour ajuster les portes: "C"  
Desserrez la vis "C".  
Ajustez la porte.  
Serrez la vis "C".

# 22

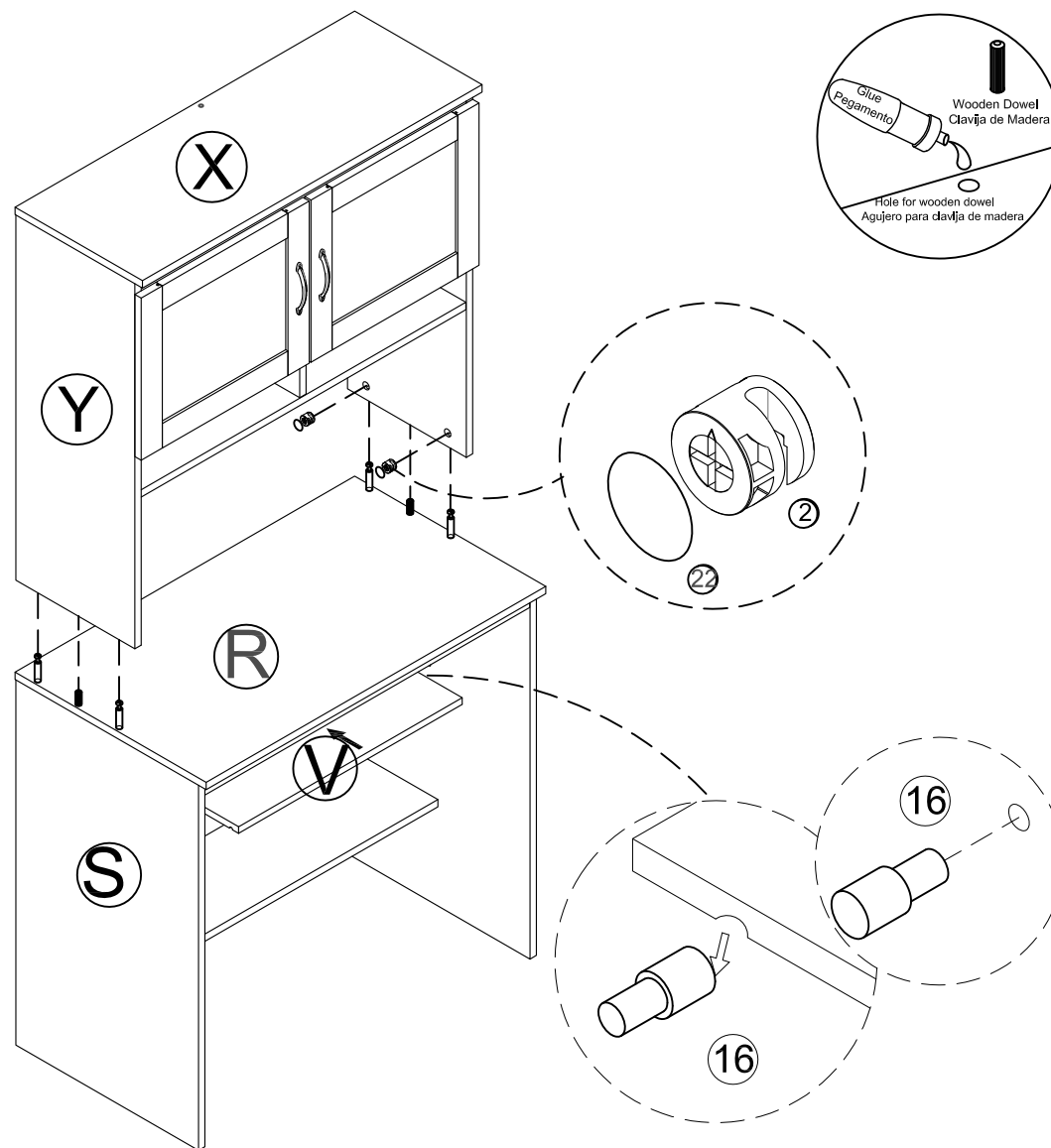
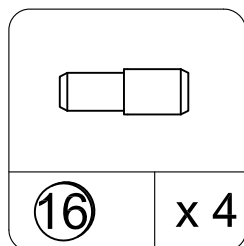
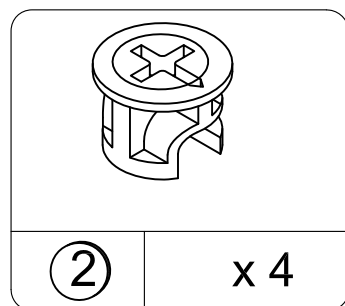
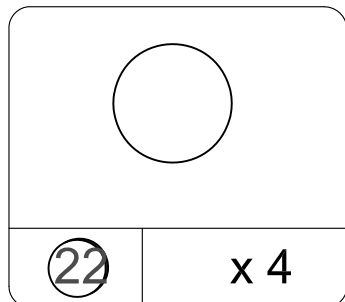
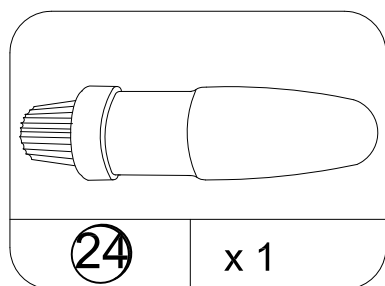

# 23

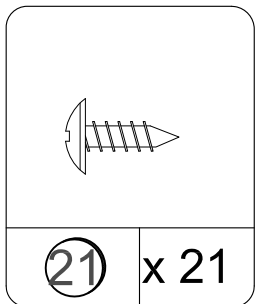
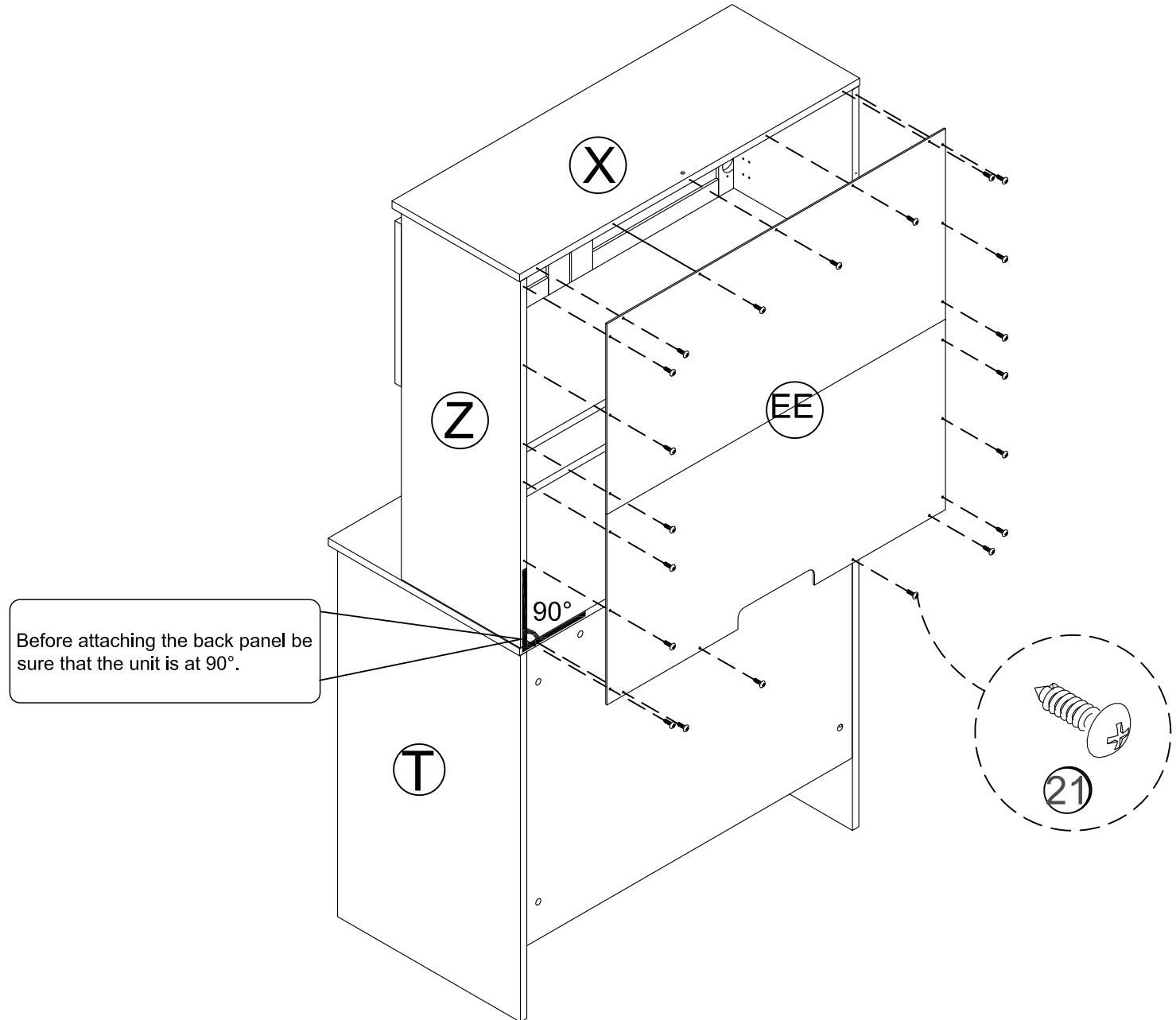

---

# 24

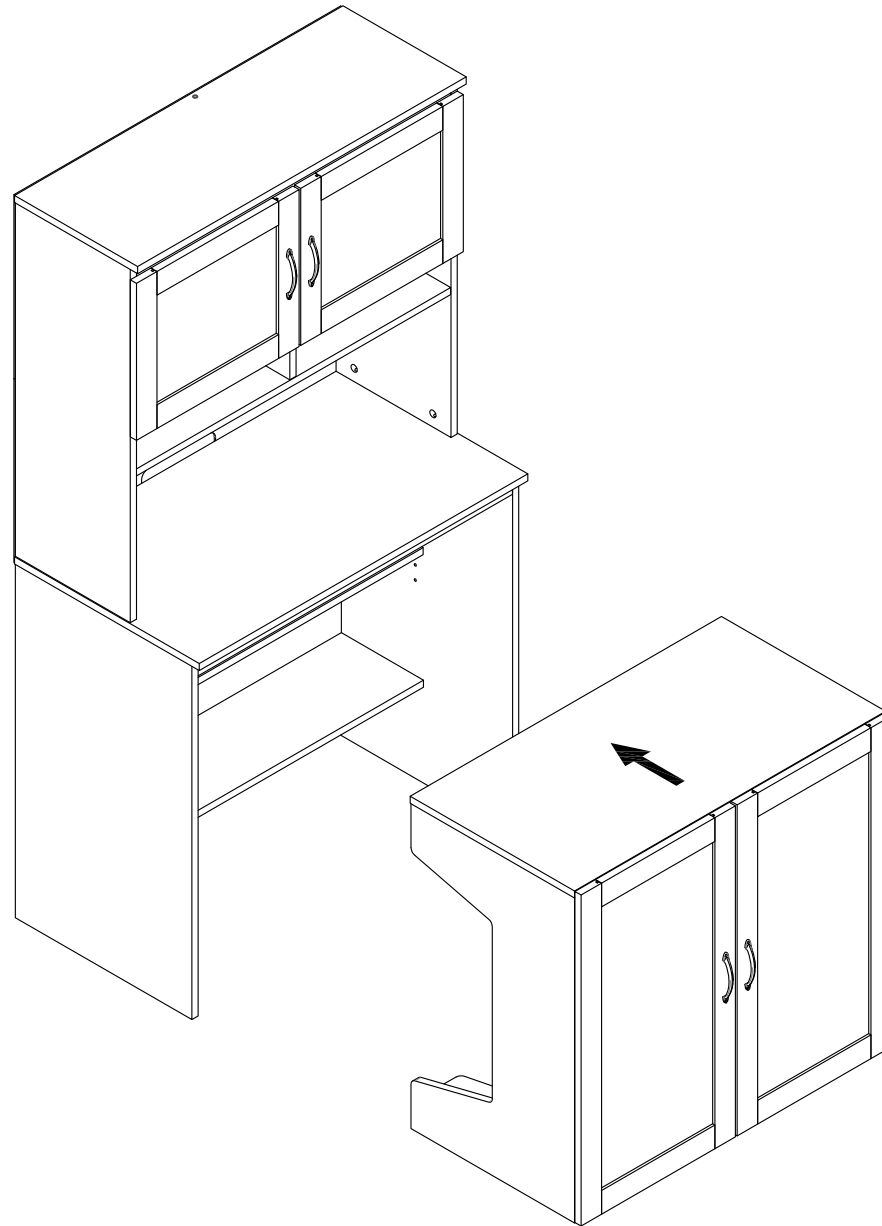



# 25

Fasten the ANGLE BRACKET (25a) to the wall using OPTION 1 or 2 as shown.

**OPTION 1:**

Fasten the ANGLE BRACKET (25a) to a stud in the wall using the SCREW (25c).

**OPTION 2:**

Drill a 3/16" diameter hole in the wallboard. Tap the WALL ANCHOR (25b) into the hole until it is flush. Fasten the ANGLE BRACKET (25a) to the WALL ANCHOR (25b) using the SCREW (25c).

Fije el ÉQUERRE (25a) a la pared que usa la OPCIÓN 1 o 2 como mostrada.

**OPCIÓN 1:**

Fije la ÉQUERRE (25a) a una viga en la pared con el VIS (25c).

**OPCIÓN 2:**

Taladre un agujero de un diametro de 3/16" en la pared. Martille el ANCRAGE MURAL (25b) dentro del agujero hasta que est<sup>á</sup> al ras de la pared. Fije la ÉQUERRE (25a) a la ANCRAGE MURAL (25b) con el VIS (25c).

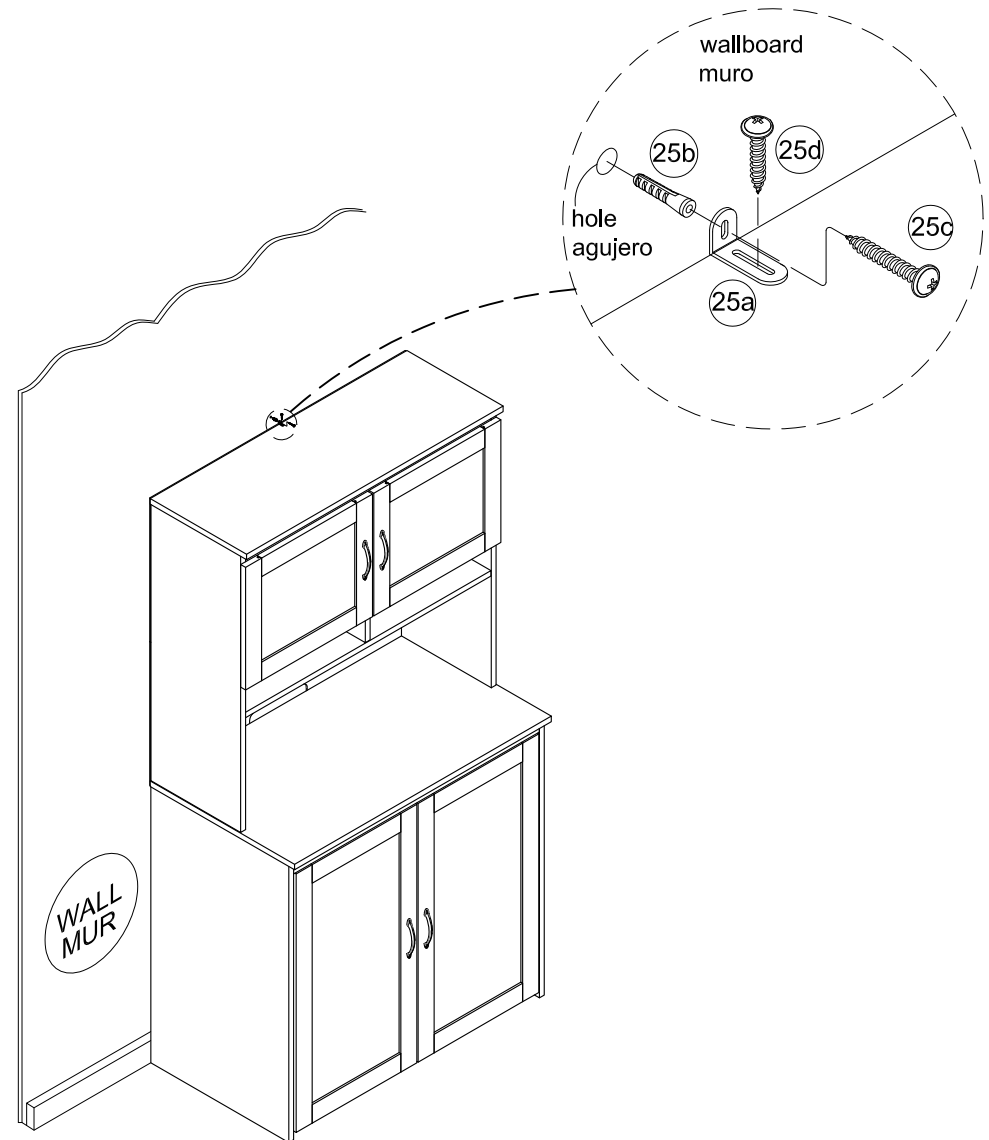
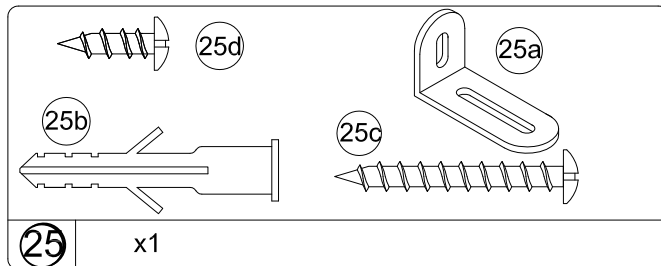

WEIGHT LIMITS:  
LÍMITES DE PESO:

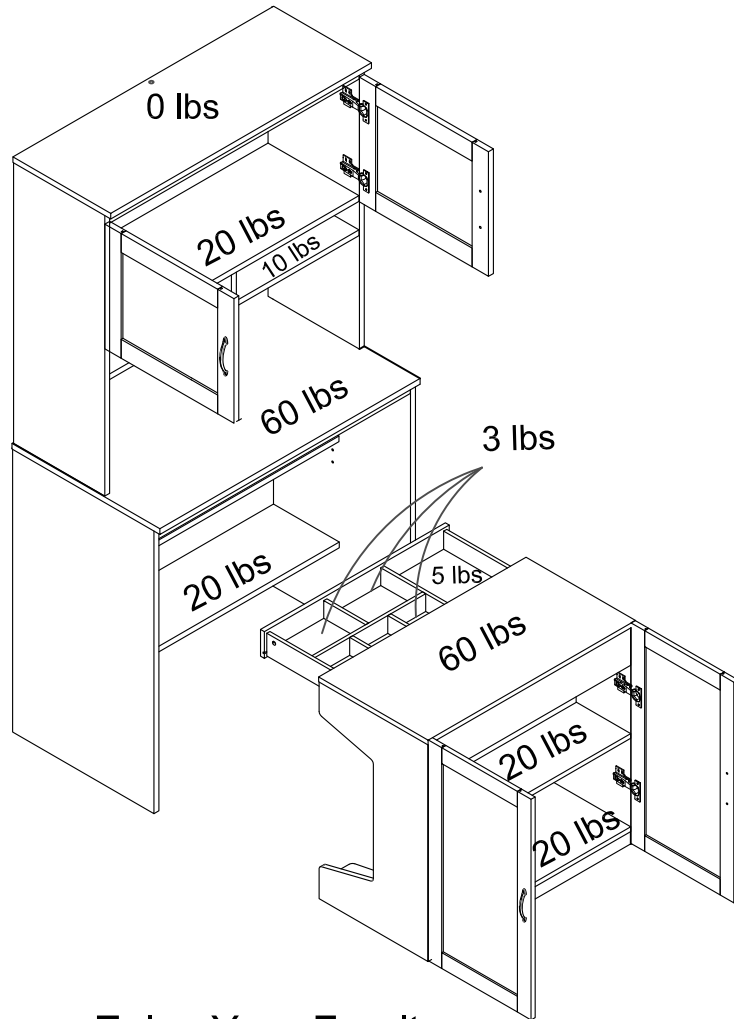

Enjoy Your Furniture  
Disfrute de su mueble

This unit has been designed to support the maximum loads shown. Exceeding these load limits could cause sagging, instability, product collapse, and/or serious injury.

Esta unidad se ha diseñado para apoyar las cargas máxima se mostradas. Exceder estos límites de carga podría causar ceder, inestabilidad, derrumbamiento del producto, y lesión seria.

**▲ WARNING**

Please make sure that all objects are removed before moving the assembled unit. The unit must be team lifted, not dragged or pushed. Failure to do so could cause instability, product collapse, and/or serious injury.

**▲ ADVERTENCIA**

Por favor mueva el mueble cuidadosamente con la ayuda de otra persona. levante y mueva el mueble a su lugar. no lo arrastre o empuje, de lo contrario puede haber inestabilidad en el mueble y este puede colapsar u ocasionar graves lesiones.