

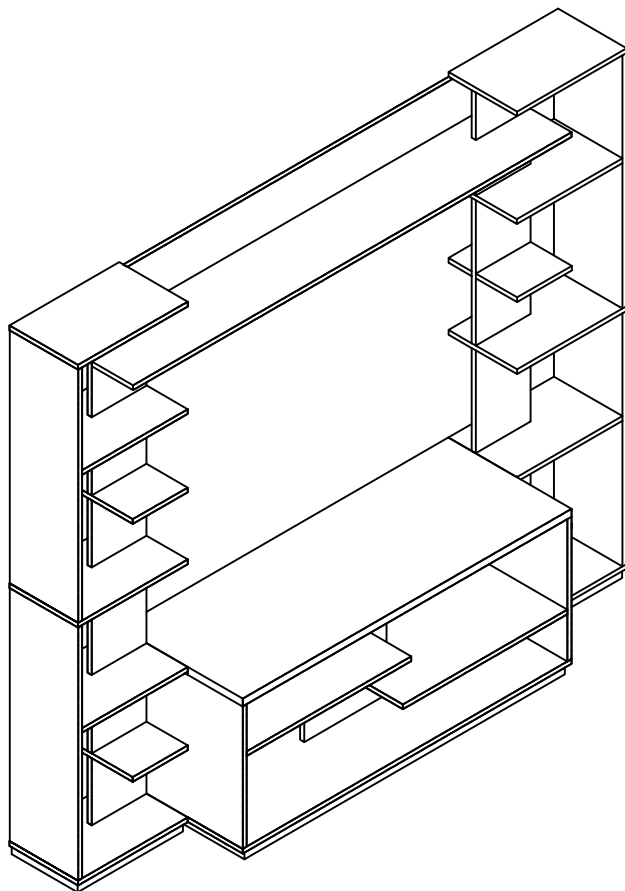

# 1617096



THIS INSTRUCTION BOOKLET CONTAINS **IMPORTANT** SAFETY INFORMATION. PLEASE READ AND KEEP FOR FUTURE REFERENCE.

ESTE FOLLETO DE INSTRUCCION CONTIENE INFORMACION **IMPORTANTE** DE SEGURIDAD. POR FAVOR LEA Y GUARDE PARA REFERENCIA FUTURA.

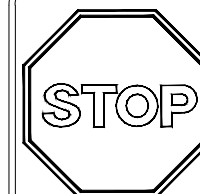

**DO NOT RETURN PRODUCT TO THE STORE**  
Individual stores do not stock parts.

**NO DEVUELVA ESTE PRODUCTO A LA TIENDA**  
Las tiendas no almacenan partes.

Lot Number / Número de Lote: \_\_\_\_\_

Date Of Purchase / Fecha de Compra: \_\_\_/\_\_\_/\_\_\_

If a part is missing or damaged, call our toll-free customer service line. We will gladly ship your replacement parts FREE of charge.

Si faltan partes o piezas, o éstas están dañadas, llame gratis al teléfono de servicio al cliente. Con gusto le enviaremos las partes sin cargo alguno.

Need Parts or Assistance?  
Necesitas partes o asistencia?

**1-800-489-3351**

or access our website  
o visite nuestra página de internet

@[www.altrafurniture.com](http://www.altrafurniture.com)

For prompt, reliable service please have your assembly manual ready.  
Para obtener servicio rapido y confiable, por favor tenga esta manual a la mano.

Recommended # of people needed for assembly: 2

El número recomendado de personas necesarias para el montaje: 2

Thank you for purchasing from Altra Furniture.  
Visit [www.altrafurniture.com](http://www.altrafurniture.com) to view the limited warranty valid in the U.S. and Canada.

## ALTRA FURNITURE CUSTOMER SERVICE

Gracias por haber comprado de Altra Furniture.  
Visitar [www.altrafurniture.com](http://www.altrafurniture.com) para mirar la garantía limitada válida solamente en U.S.A y Canada.

## SERVICIO A LA CLIENTE DE ALTRA FURNITURE

### Before starting - Antes de empezar.

- Read each step carefully before starting. It is very important that each step of instruction is performed in the correct order. If these steps are not followed in sequence, assembly difficulties will occur.  
Leer con cuidado cada paso antes de empezar. Es muy importante de ejecutar cada paso en el orden correcto. Si los pasos no están ejecutados en secuencia, ocurrirá dificultades en el montaje.
- Make sure all parts are included. Most board parts are labeled or stamped on the raw edge.  
Asegurar que todas las piezas son incluidas. La mayoría de las tablas tienen las etiquetas o los sellos en el lado sin acabado.
- Work in spacious area, preferably on a carpet, near the place the unit will be used.  
Trabajar en una área espaciosa, preferible sobre alfombra, cercas del lugar donde se va a usar el mueble.
- Have the following tools close at hand.  
Tener las herramientas siguientes cerca de la mano.
- Do not use power tools to assemble your furniture. Power tools may strip or damage the parts.  
No use herramienta eléctrica para montar su unidad. Las herramientas eléctricas pueden dañar las piezas.

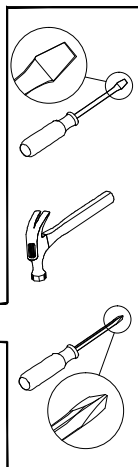

Call us at:  
Llamar a:

**1-800-489-3351**  
(in U.S.A. only)  
(Solo en U.S.A)

Monday - Friday 7:00 am - 8:00 pm Central Time	Saturday 9:00 am - 5:00 pm Central Time
--	---



Fax:  
Fax:

**1-636-745-1005**

Lunes - Viernes 7:00h - 20:00h Tiempo Central	Sabado 9:00h - 17:00h Tiempo Central
---	--

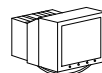

Visit our Website:

Visitar nuestro website: [www.altrafurniture.com](http://www.altrafurniture.com)



Write to:  
Escribir a:

ALTRA FURNITURE  
410 East 1st Street South Wright City, MO 63390 USA  
Attn: Service Dept.

### HELPFUL HINTS

- Visit our website for assembly video clips.
- Identify, sort and count the parts before attempting assembly.
- Call our toll free number if you need assistance identifying parts.
- Compression dowels are tapped in with a hammer.
- Slides have lips only on the right side.
- Cam locks that are properly fastened on a horizontal board will face toward the center of the unit, on a vertical board the point on the lock will face the bottom.
- Back panels provide stability and support. Use all the nails provided.
- When tapping nails into a board, be sure there are equal margins on all sides to square the unit.
- Units without the back panel installed may collapse.
- Clean the product with your favorite furniture polish and a soft cloth. **DO NOT USE** harsh chemicals or abrasive cleaners.
- Move your new furniture carefully, with two people lift and carry the unit to it's new location.
- Never push, drag or scoot your furniture (especially on carpet).
- Your furniture can be disassembled and reassembled to move.
- Additional parts are available for a nominal fee.

### NOTES UTILES

- Visitar nuestro website para mirar los videos cortos del montaje.
- Identificar, clasificar y contar las piezas antes de intentar el montaje.
- Llamar gratis a nuestro número de servicio si necesite ayuda con identificar las piezas.
- Las clavijas de compresión se taladran con un martillo.
- Las correderas sólo tienen las protrusiones en el lado derecho.
- Las cerraduras de leva que se atan propiamente en una tabla horizontal se puntan al centro de la unidad, y las en una tabla vertical se puntan al fondo.
- Los paneles traseros se mantienen la estabilidad. Usar todos los tornillos proporcionados.
- A taladrar los tornillos en una tabla, asegurarse que hay márgenes iguales en todos los lados para cuadrar la unidad.
- Las unidades sin panel trasero pueden derrumbarse.
- Limpiar la unidad con su pulimento favorito de mueble y una tela suave. **NO UTILIZAR** productos con químicos duros o abrasivos.
- Mover su mueble nuevo cuidadosamente, con dos personas levantar la unidad a su nuevo lugar.
- Nunca empujar o arrastrar su mueble (especialmente en alfombra).
- Poderse desmontar y volver a montar su mueble de para mover.
- Piezas adicionales están disponibles para una cuota nominal.

# PARTS -PIEZAS

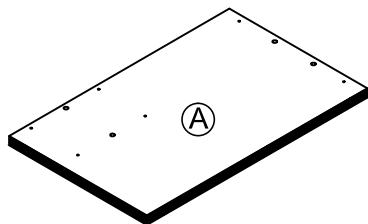

Left top  
Arriba a la izquierda  
T1617096010HC

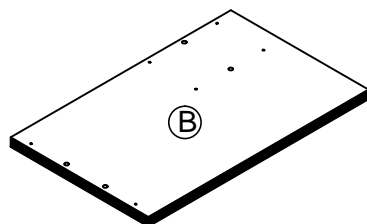

Right top  
La parte superior derecha  
T1617096020HC

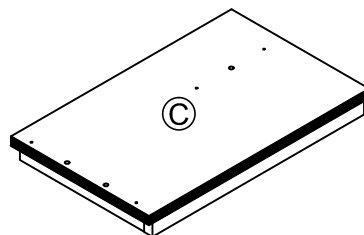

Left base  
Base de la izquierda  
T1617096030HC

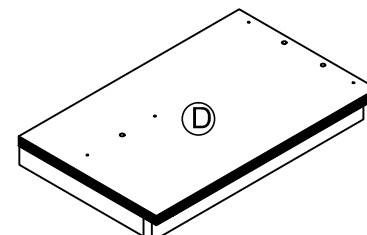

Right base  
Base de derecho  
T1617096040HC

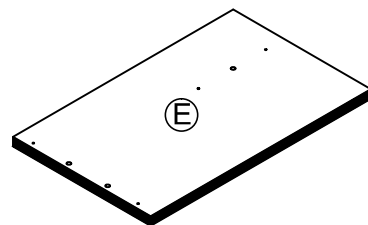

Left fixed shelf  
Plataforma fija de izquierda  
T1617096050HC

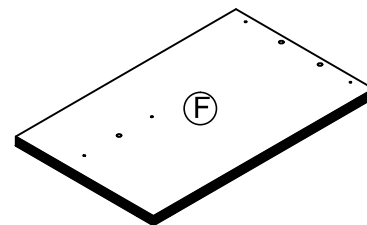

Right fixed shelf  
Plataforma fija de Derecho  
T1617096060HC

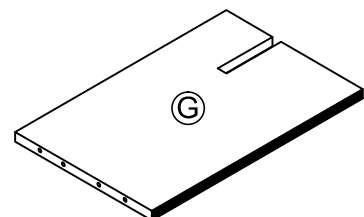

Left fixed shelf (2)  
Izquierda plataforma fija (2)  
T1617096070HC

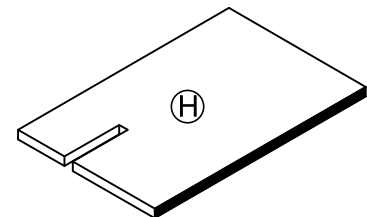

Right fixed shelf (2)  
Plataforma fija de Derecho (2)  
T1617096080HC

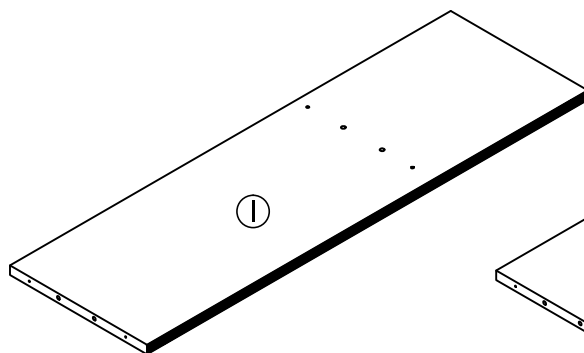

Upper side panel (2)  
Panel lateral superior (2)  
T1617096090HC

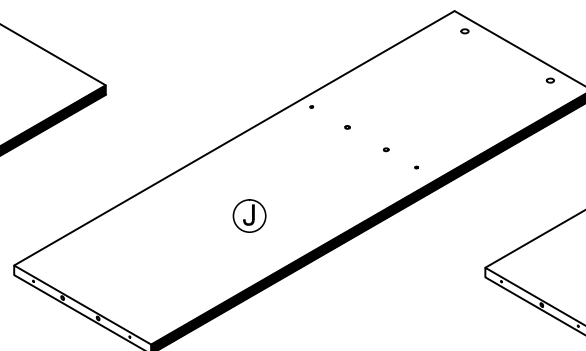

Lower side panel (2)  
Parte inferior del panel (2)  
T1617096100HC

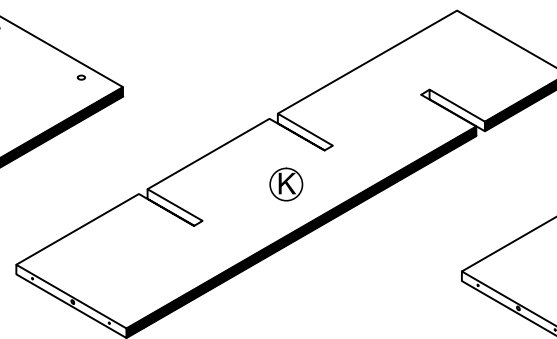

Upper back panel  
El panel superior de la espalda  
T1617096110HC

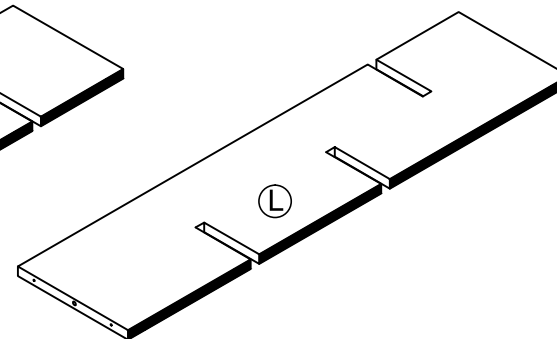

Upper back panel  
El panel superior de la espalda  
T1617096120HC

**PARTS -PIEZAS**

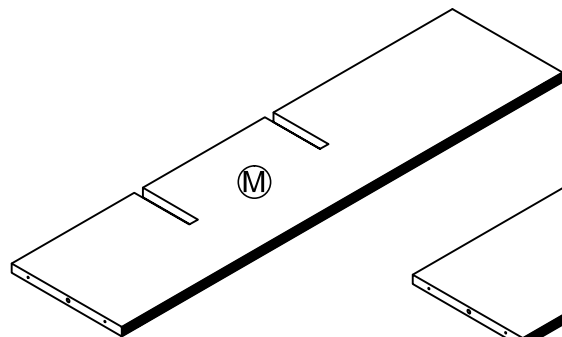

Lower back panel  
Baje el panel posterior  
T1617096130HC

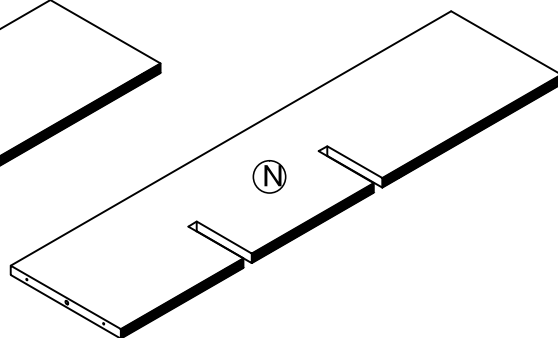

Lower back panel  
Baje el panel posterior  
T1617096140HC

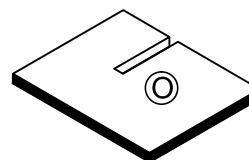

Small shelf (4)  
Pequeño estante (4)  
T1617096150HC

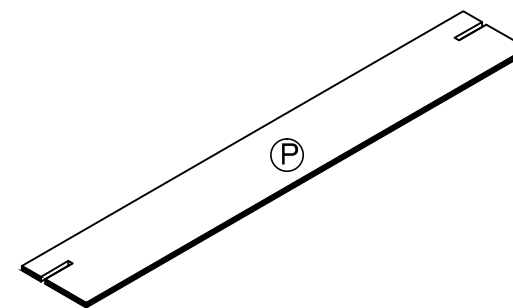

Bridge rail  
Puente de ferrocarril  
T1617096160HC

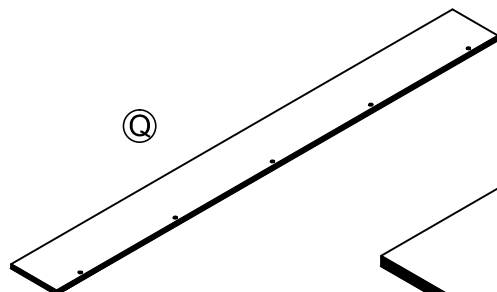

Bridge back panel  
Puente de ferrocarril  
T1617096170HC

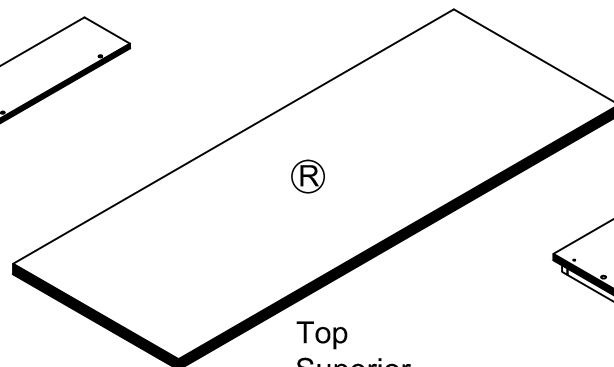

Top  
Superior  
T1617096180HC

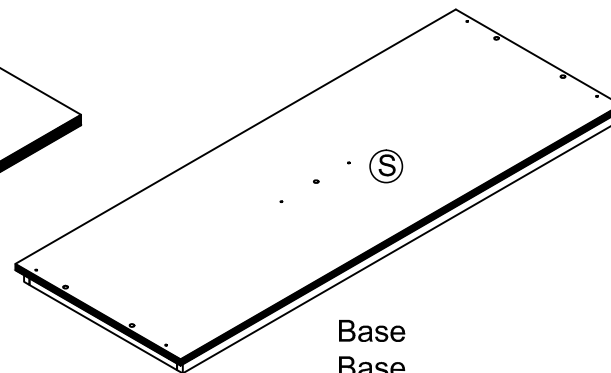

Base  
Base  
T1617096190HC

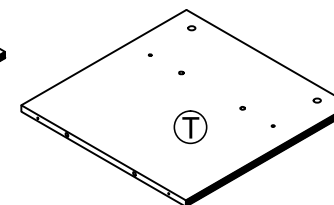

Left side panel  
Panel del lado izquierdo  
T1617096200HC

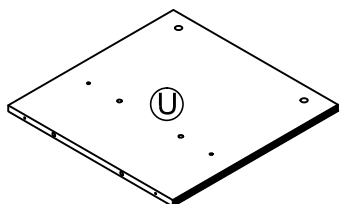

Right side panel  
El panel lateral derecho  
T1617096210HC

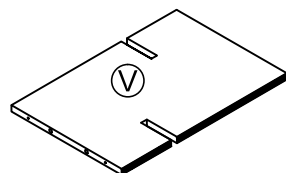

Partition  
Tabique  
T1617096220HC

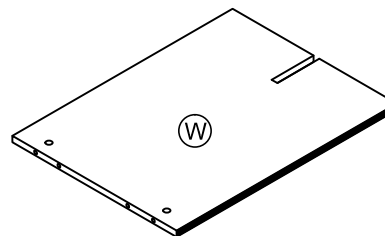

Fixed shelf (2)  
estante fijo (2)  
T1617096230HC

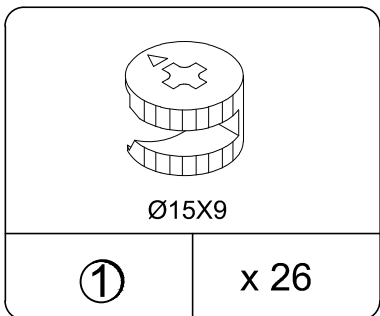

Cam Lock  
Serrure de came  
THC0003

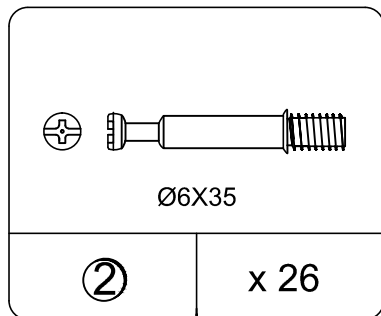

Cam Bolt  
Boulon de came  
THC0025

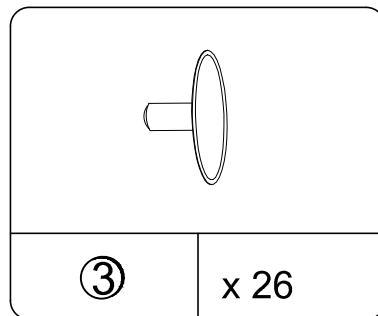

Cam Lock Cap  
Capuchon de serrure de came  
THC0006

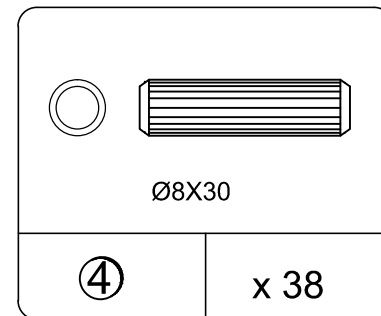

Wood Dowel  
Goujon en bois  
THC0024

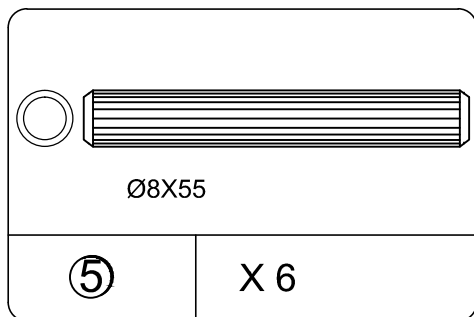

Wooden Dowel  
Goujon en bois  
THC0137

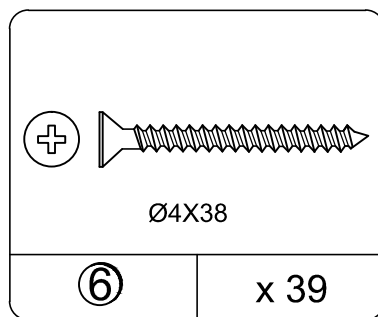

Screw  
Tornillo  
THC0105

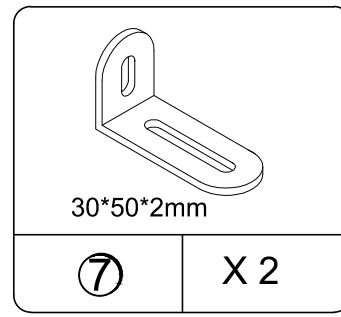

Wall Bracket  
Soporte para la pared  
THC0091

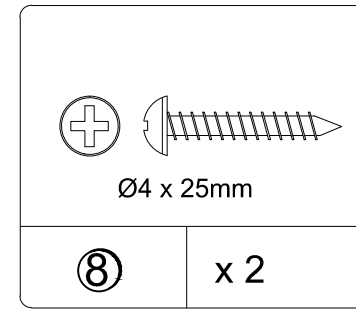

Screw  
Tornillo  
THC0092

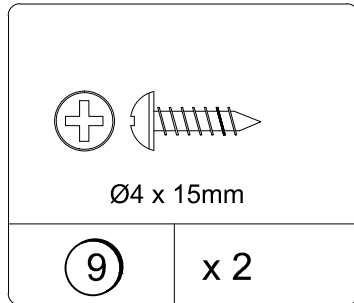

Screw  
Tornillo  
THC0093

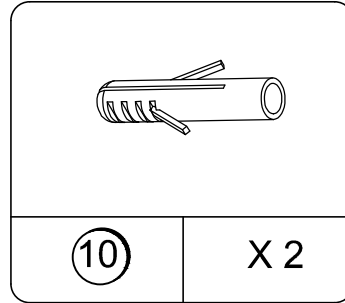

Wall anchor  
Ancla de pared  
THC0017

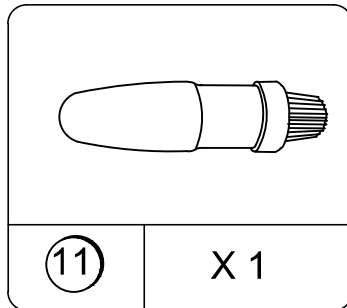

Glue  
Colle  
THC0012

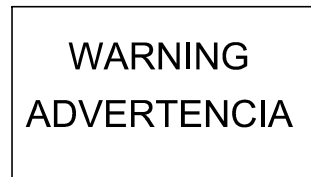

Warning label  
Etiqueta de Advertencia  
THC0135

This illustration shows how the CAM fastening system works.  
Esta ilustración muestra el sistema de fijación de leva y como funciona.

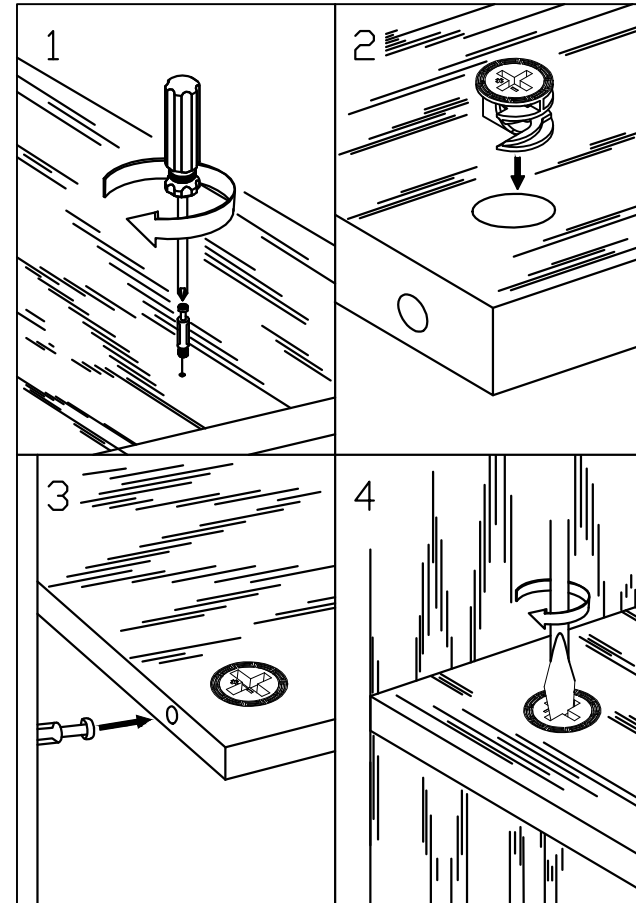

To view a video on how the CAM fastening system works, download a free QR-reader on your smartphone, then scan the code.

Para ver un video de como funciona el sistema de sujeción CAM, descargue una aplicación gratis que podrá ver en su teléfono móvil, entonces escanee el código.

# 1

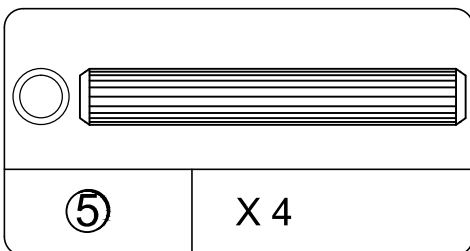
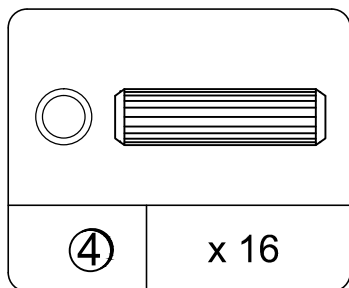
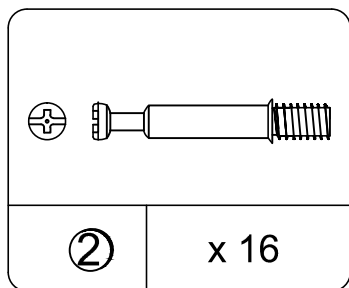
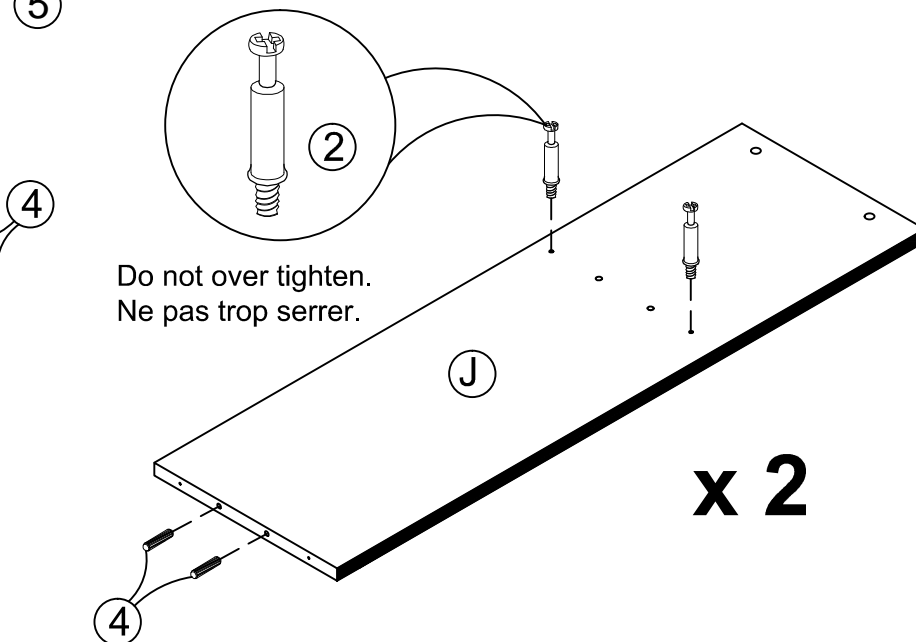
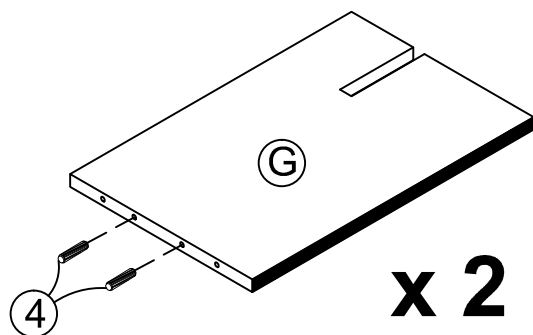
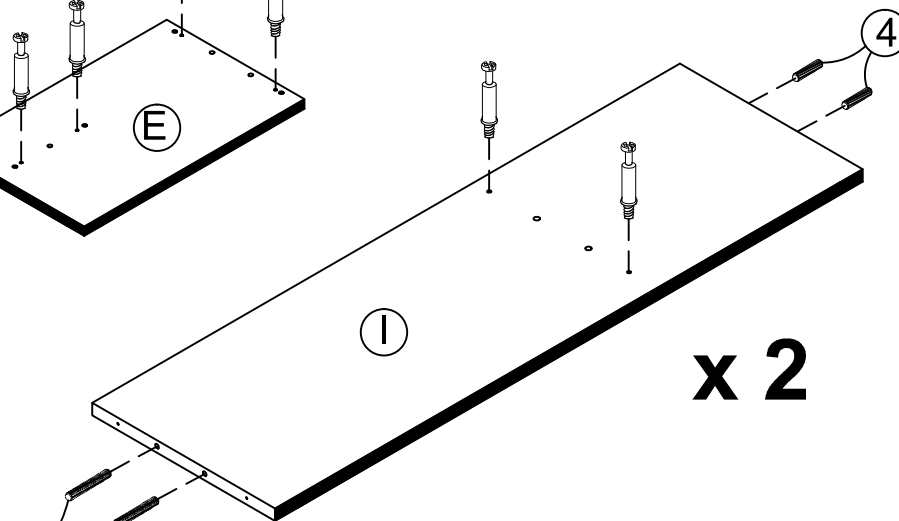
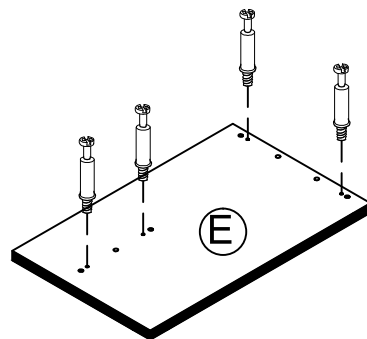
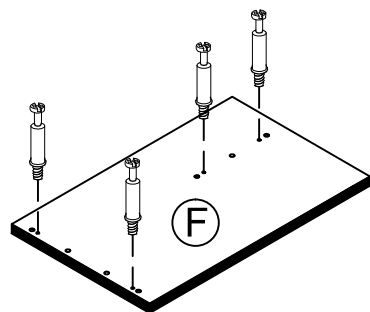

# 2

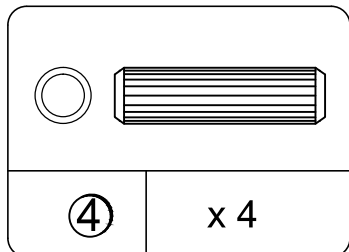
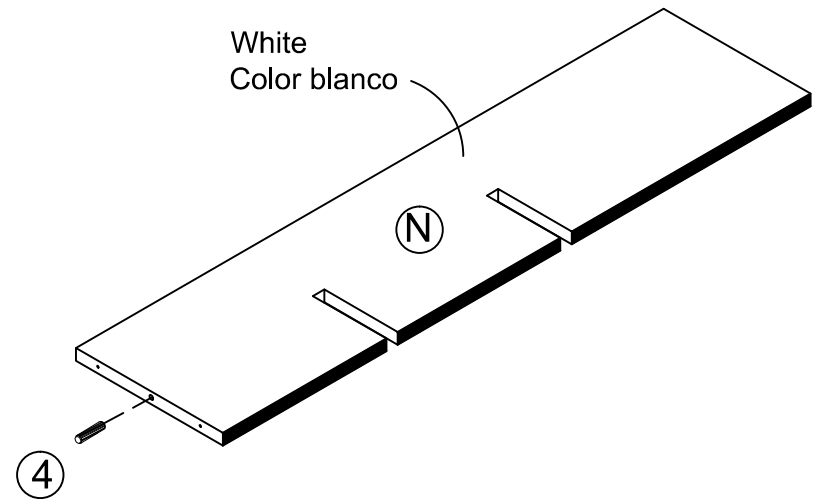
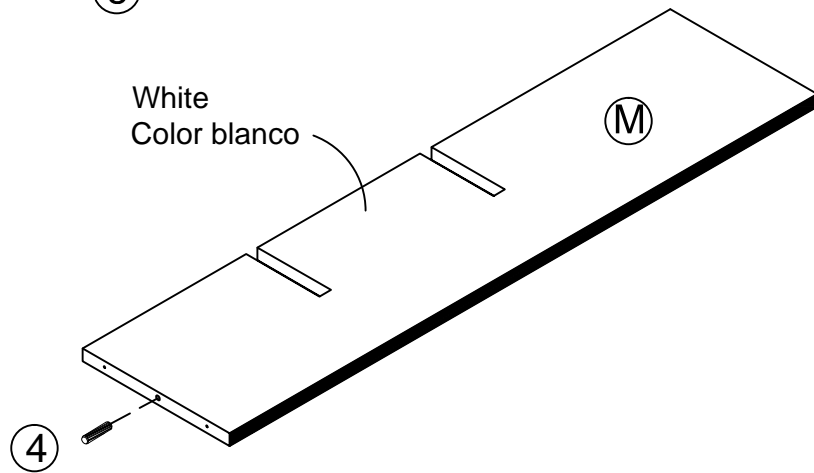
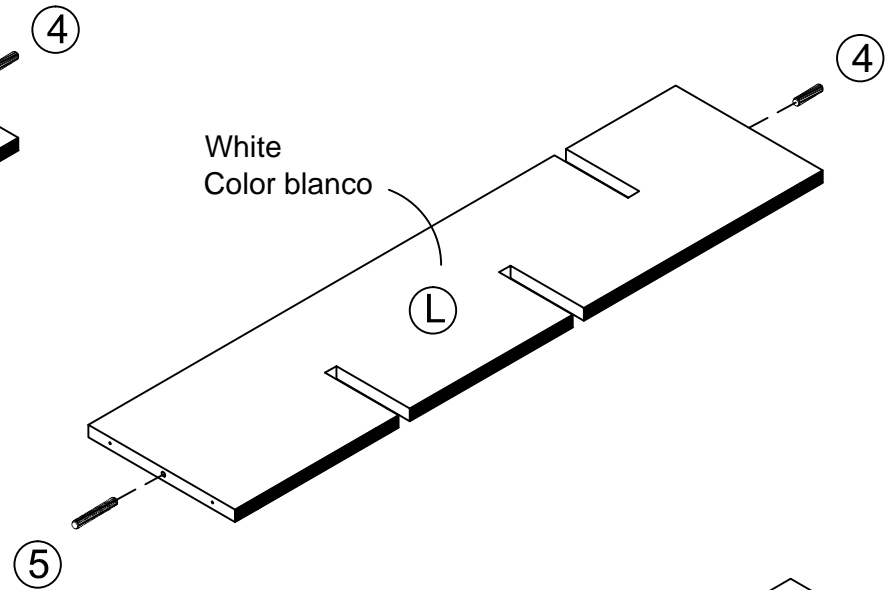
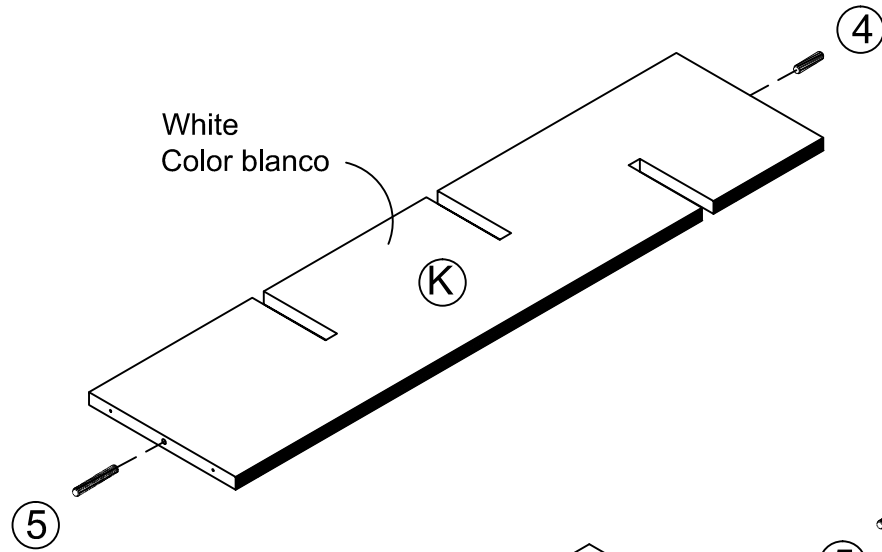



# 3

Two sides of back panels are white and black separately, white or black as the front color can be achieved by assembly.

If you prefer the front of back panels to be white, please follow below assembly processes(3-11).

If you prefer the front of back panels to be black, please follow below assembly processes(12-20).

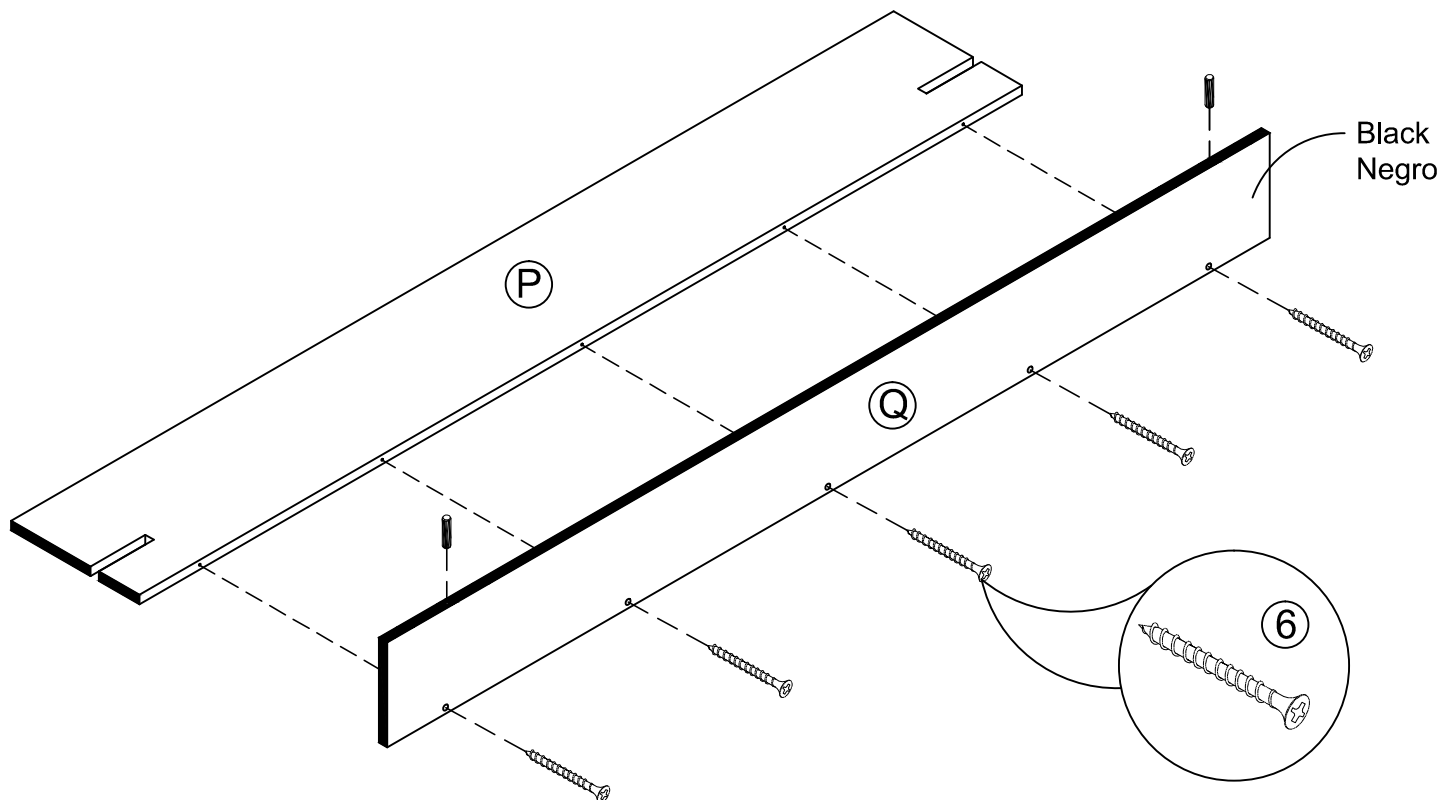
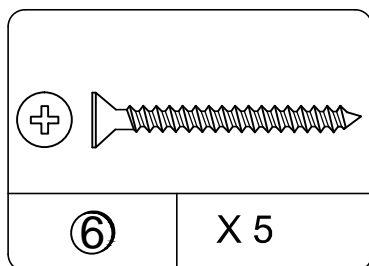
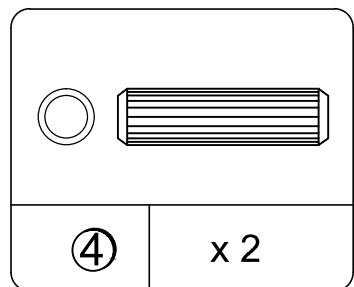

# 4

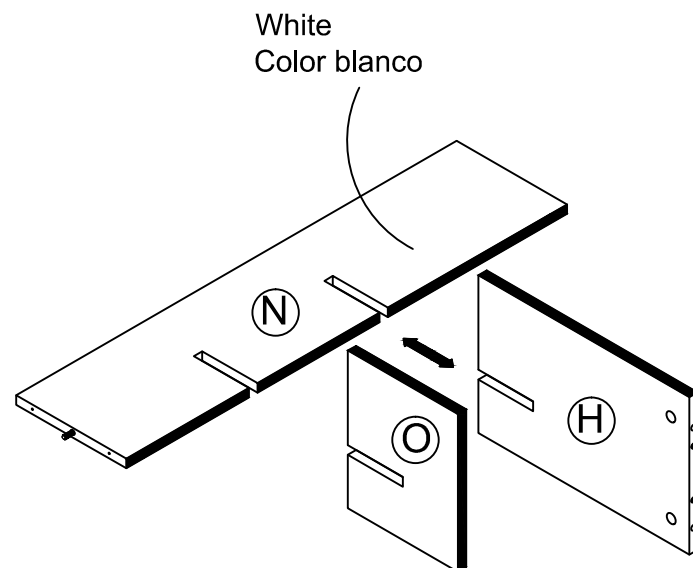
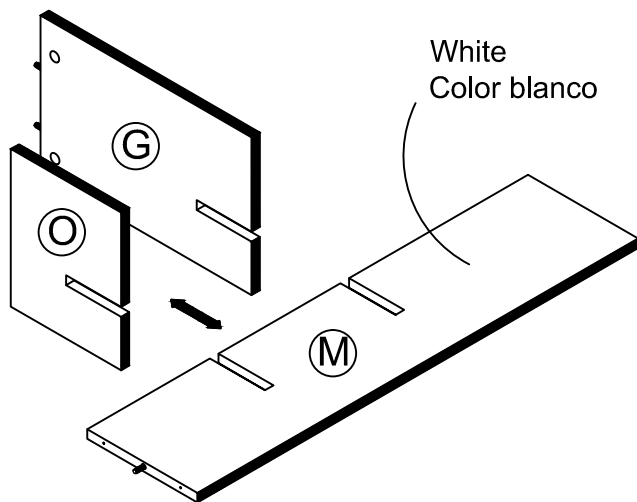
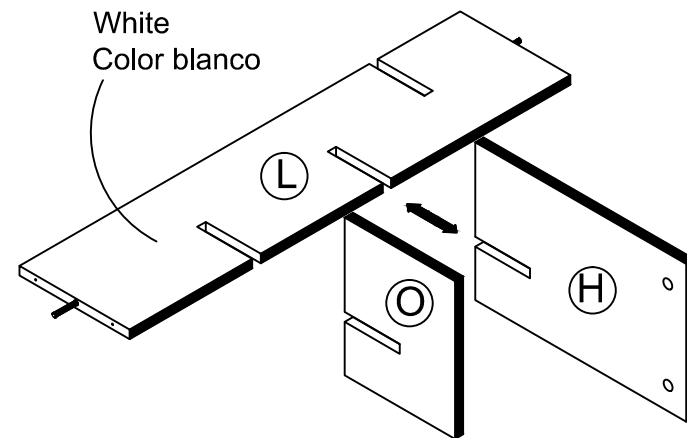
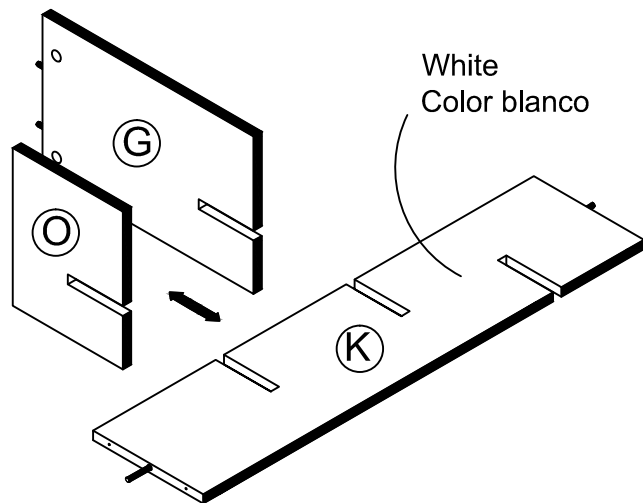

# 5

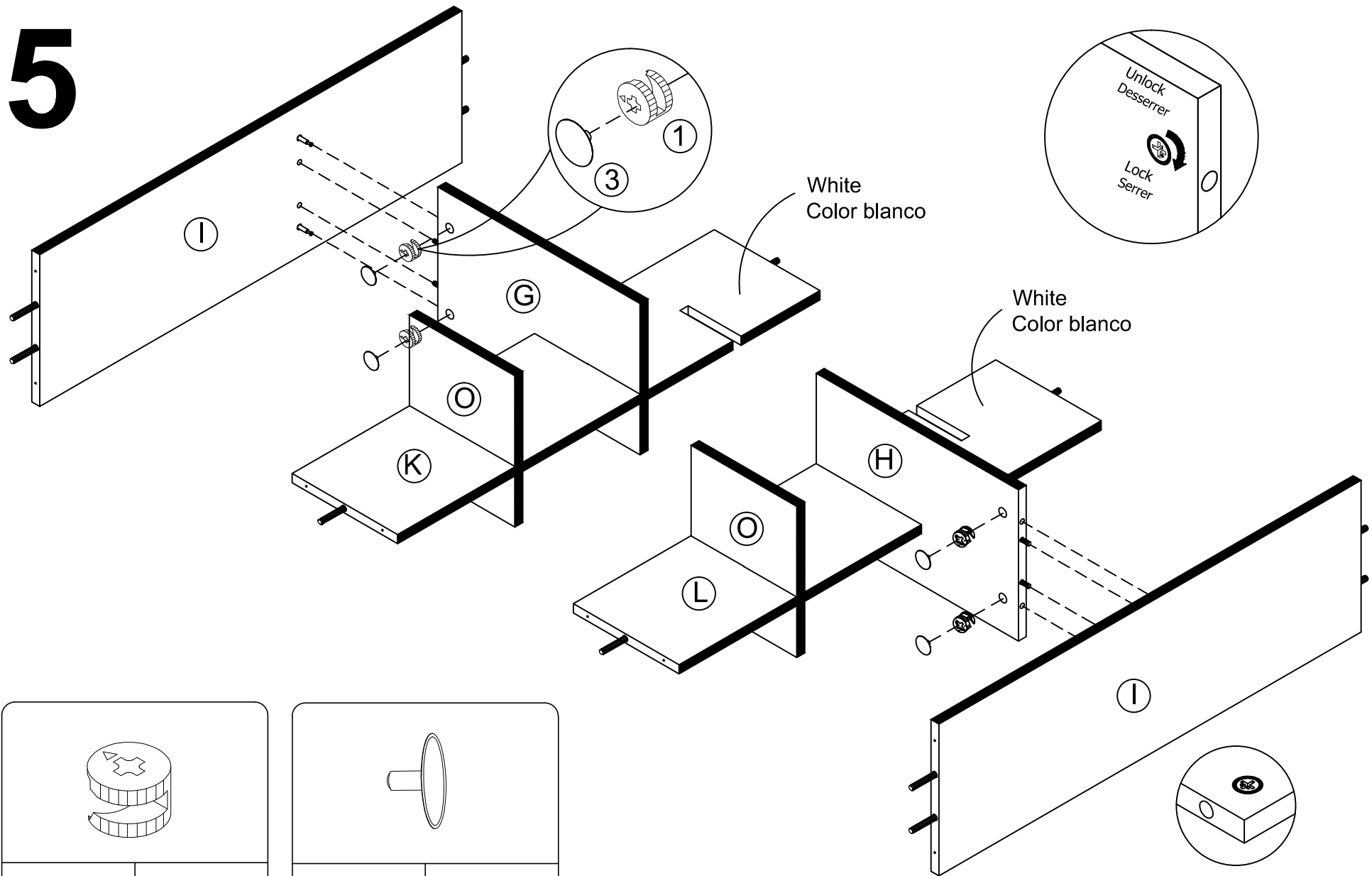

①	x 4

③	x 4

Proper orientation of cam lock  
Bonne orientation de la serrure de came

# 6

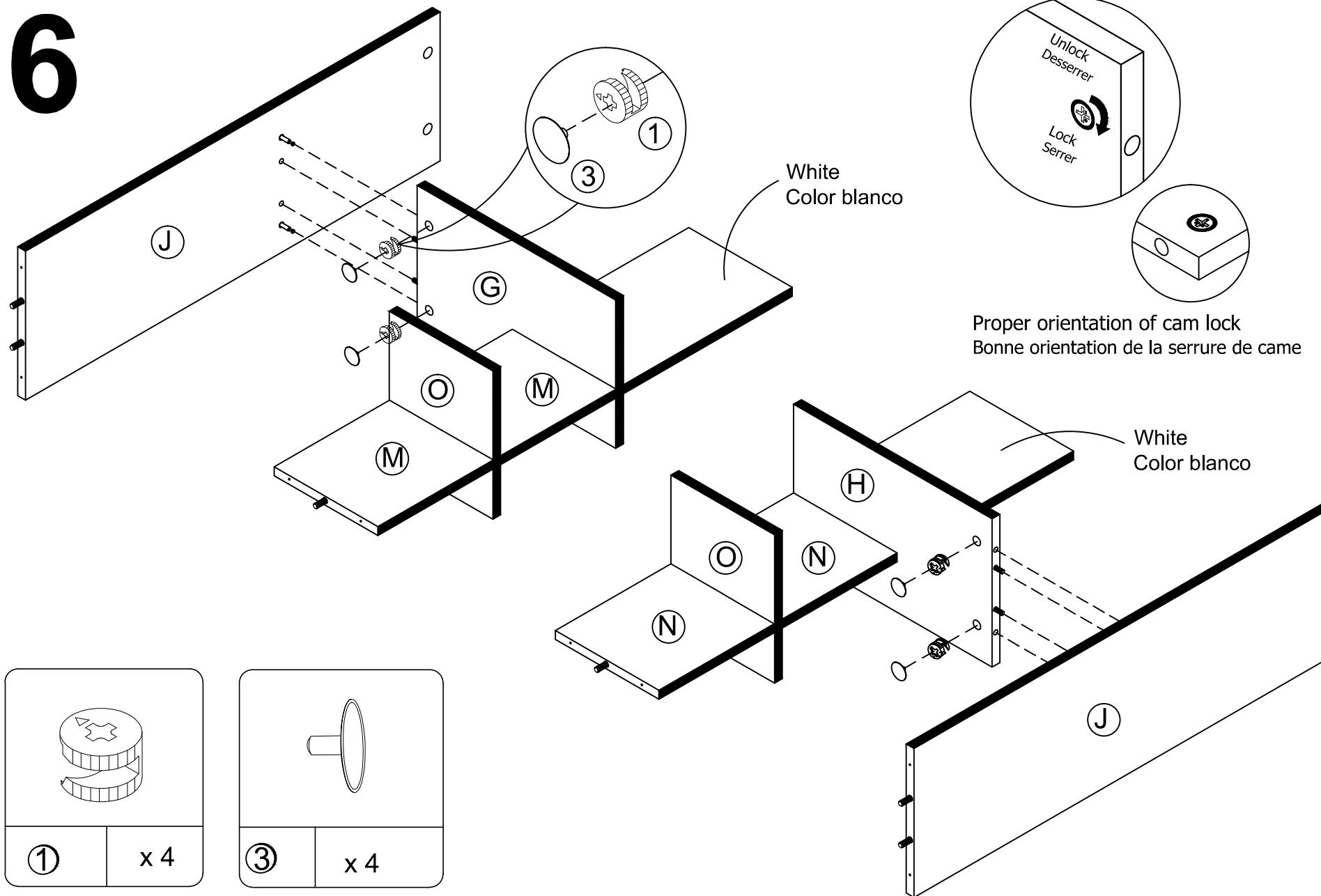



# 7

White  
Color blanco

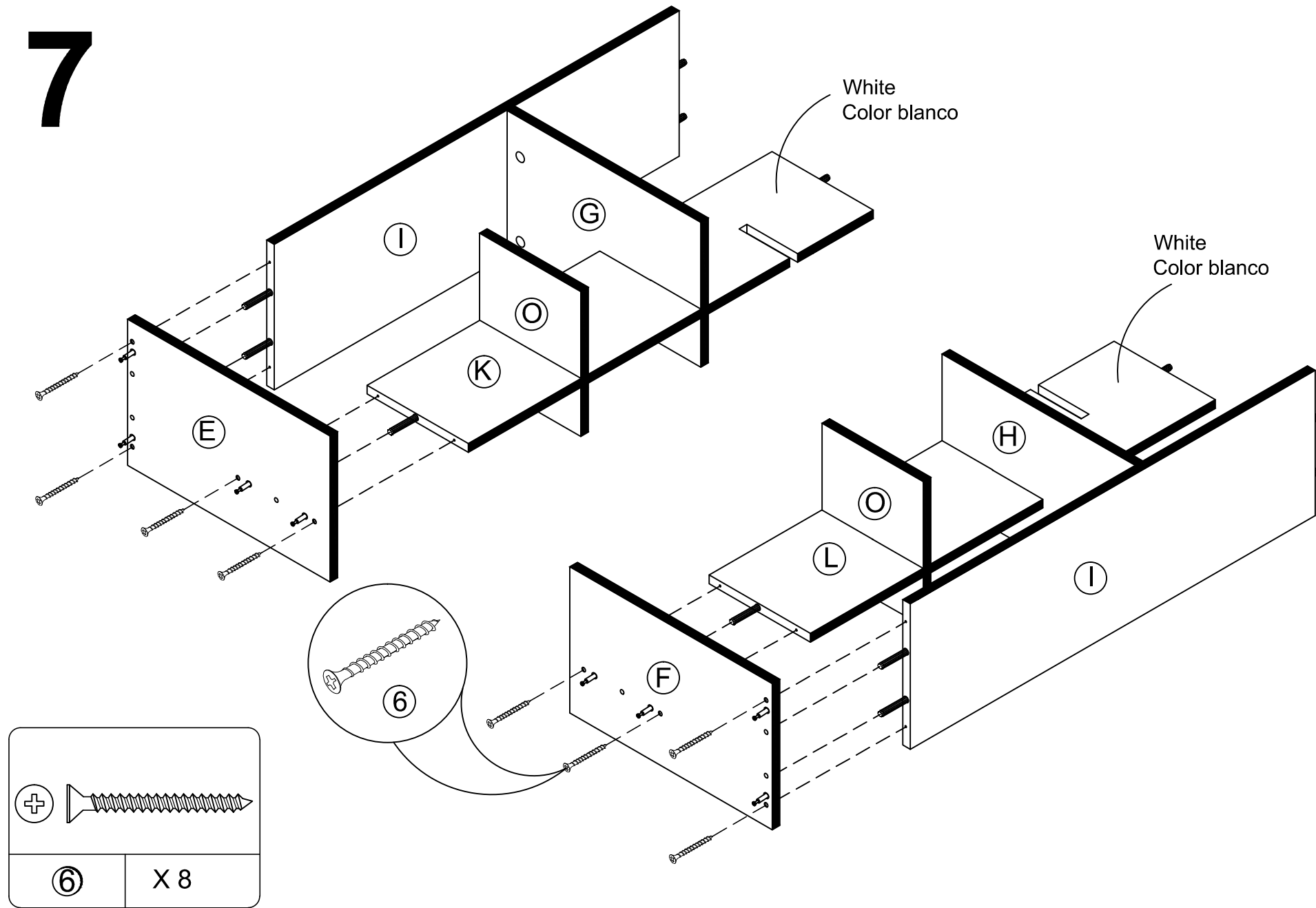
White  
Color blanco



	
⑥	X 8

# 8

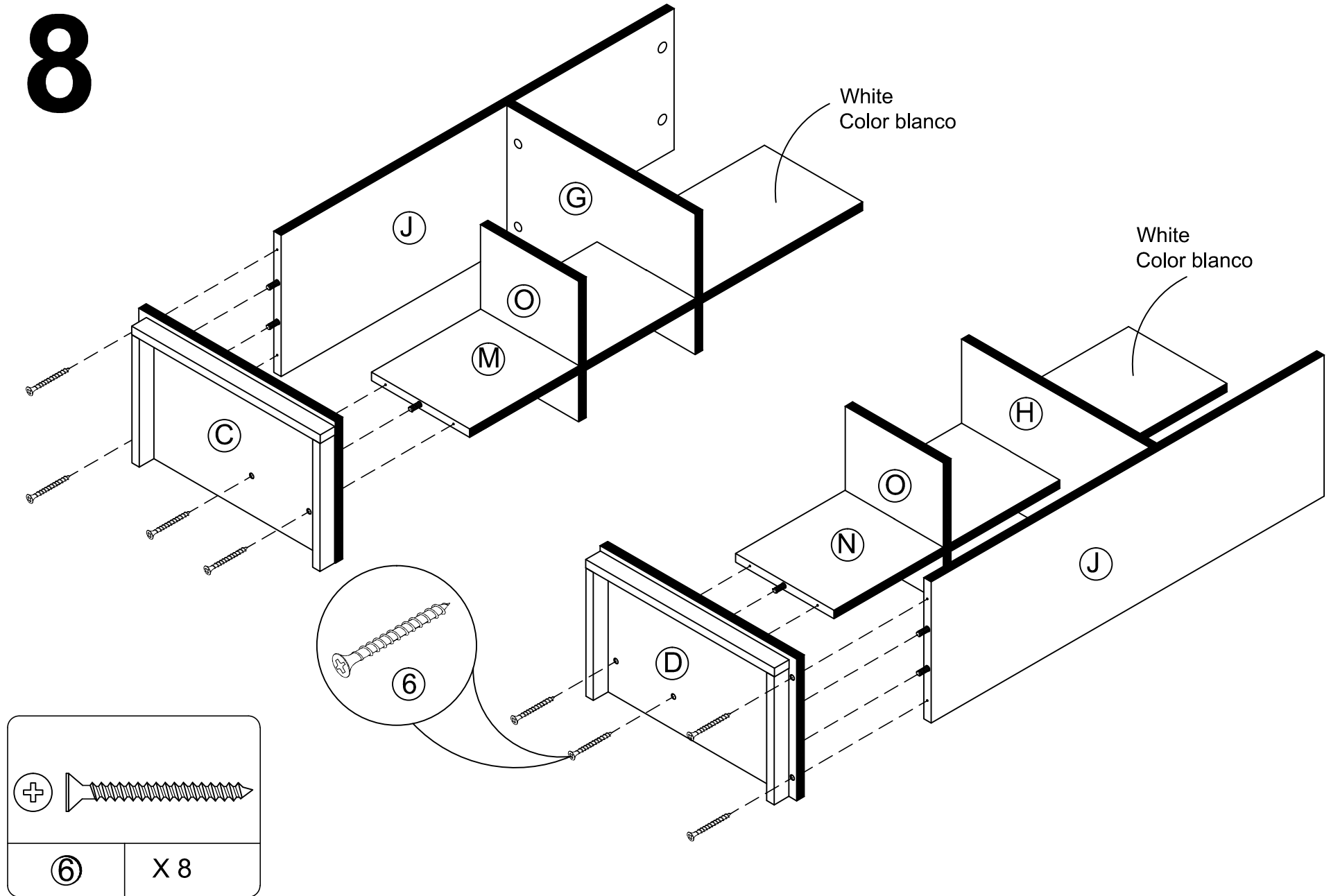

# 9

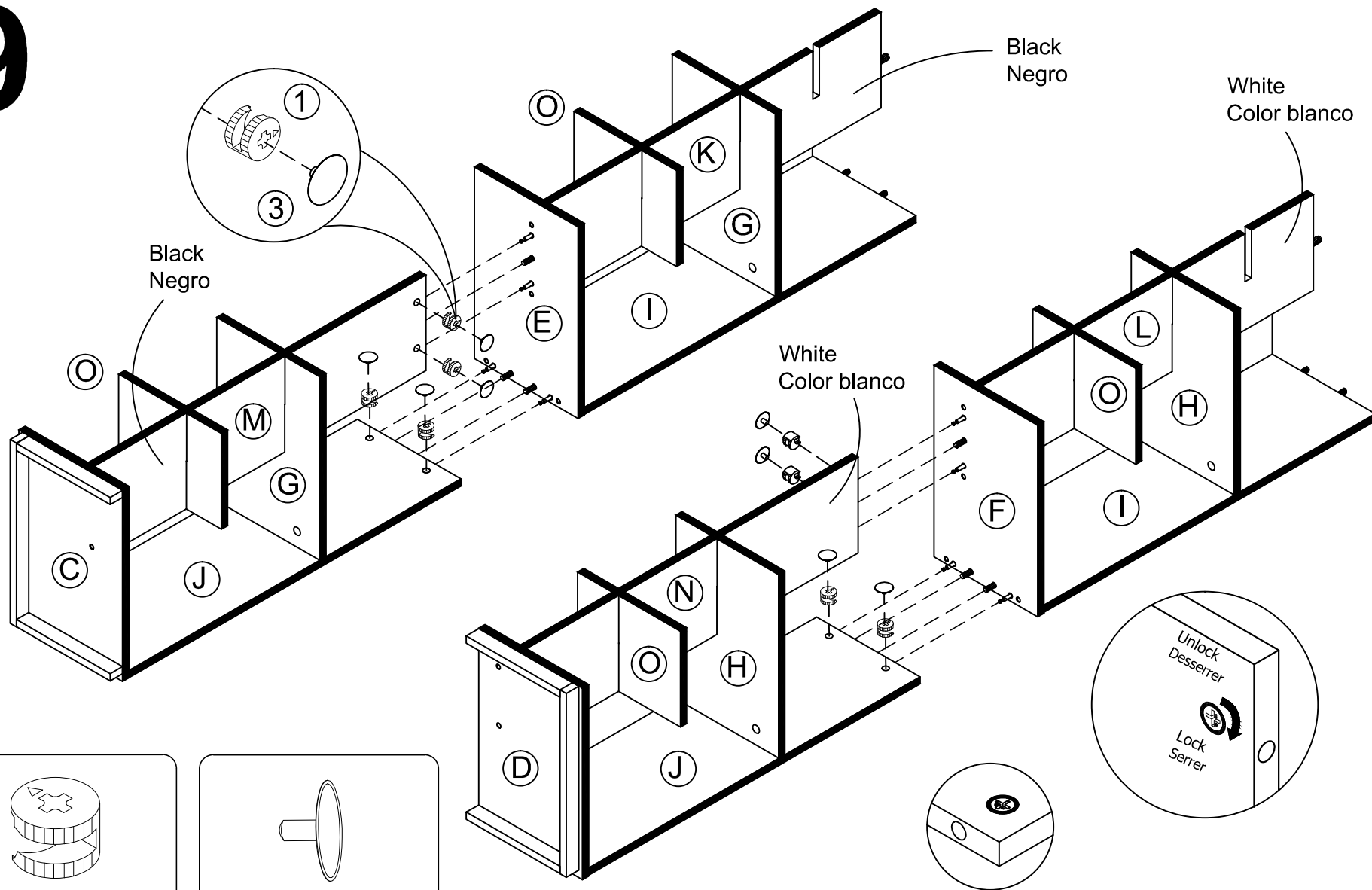

Proper orientation of cam lock  
Bonne orientation de la serrure de came

# 10

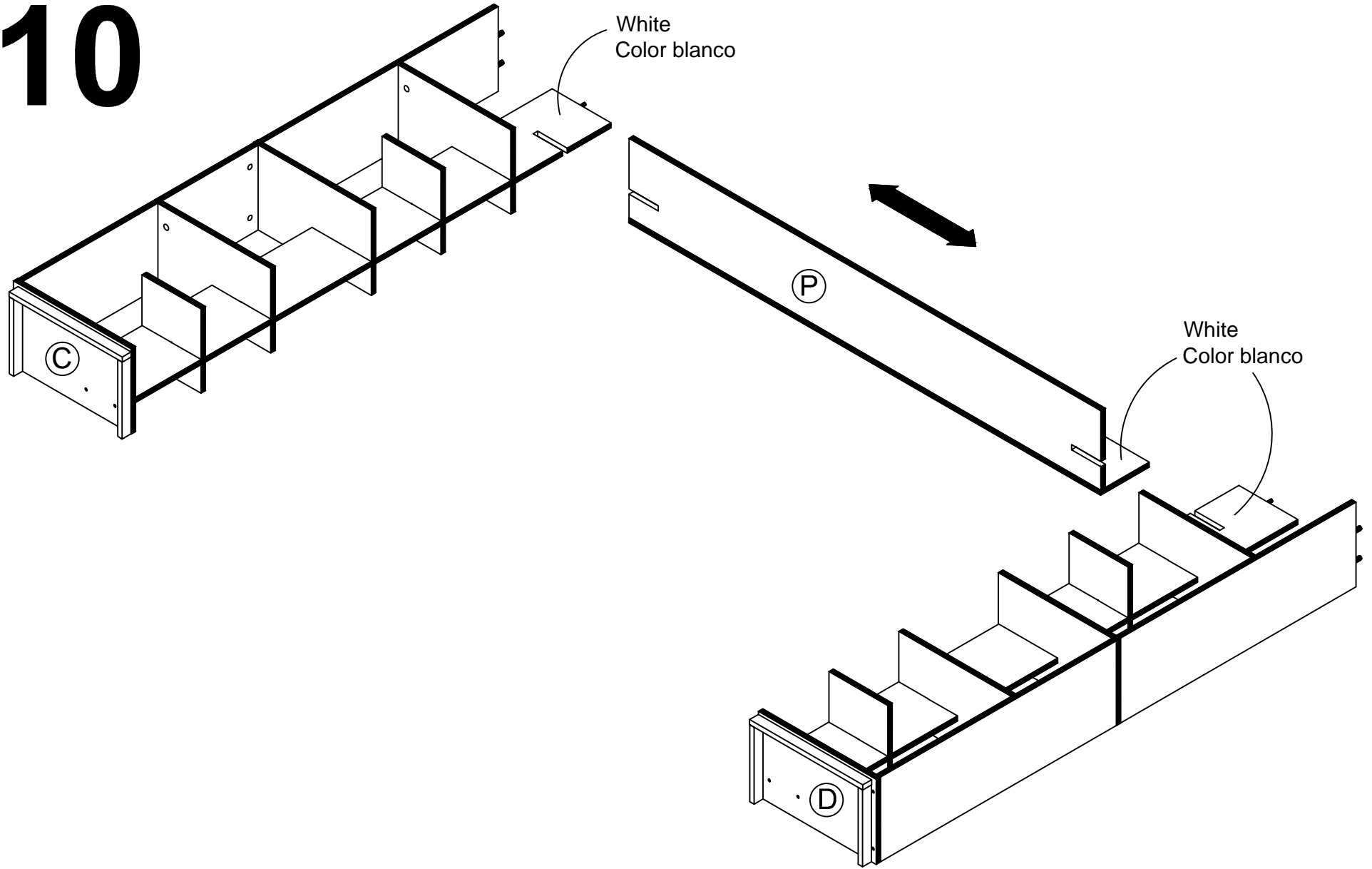



# 11

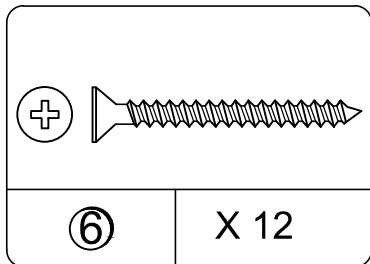
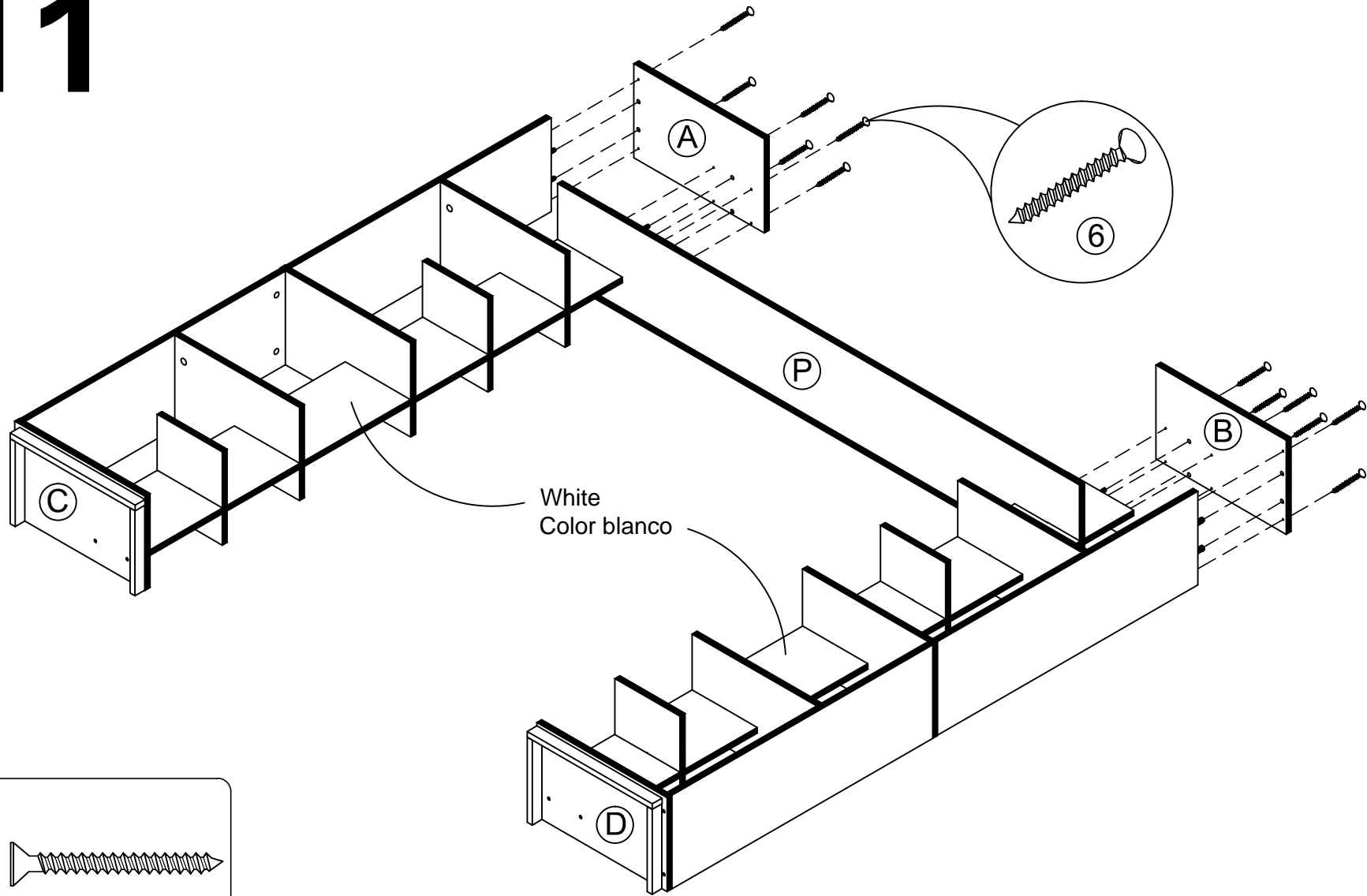

# 12

If you prefer the front of back panels to be black, please follow below assembly processes(12-20).

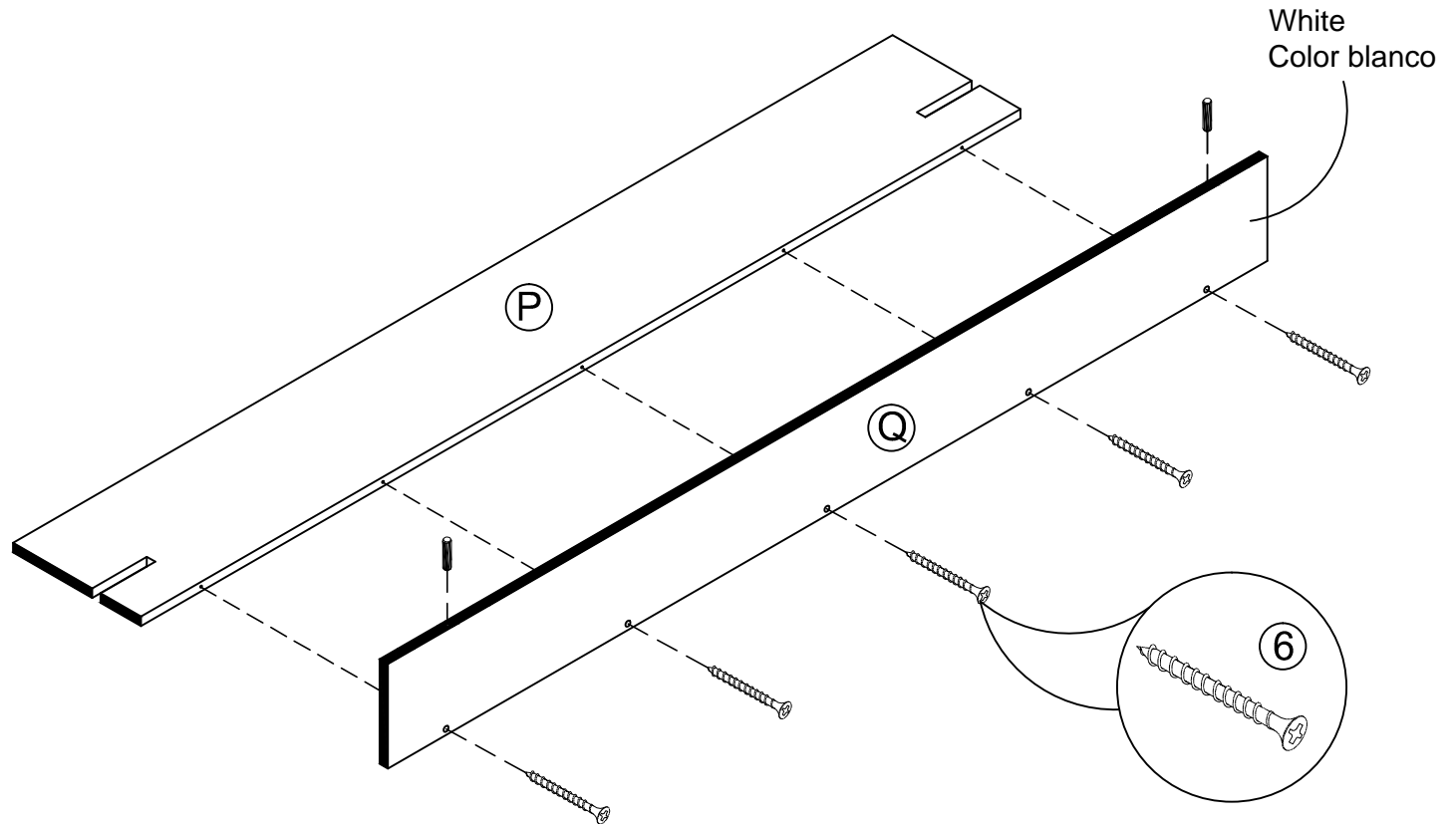
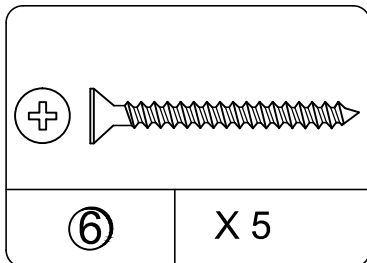
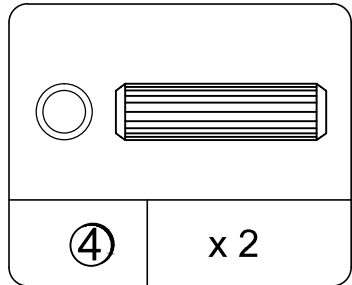

# 13

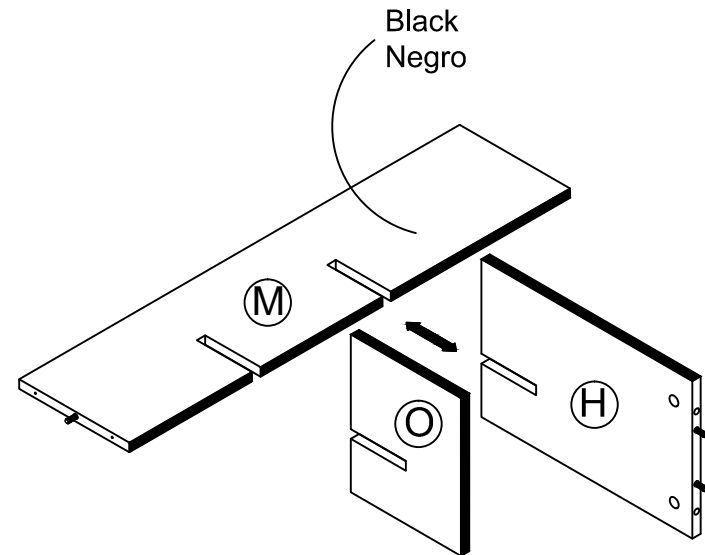
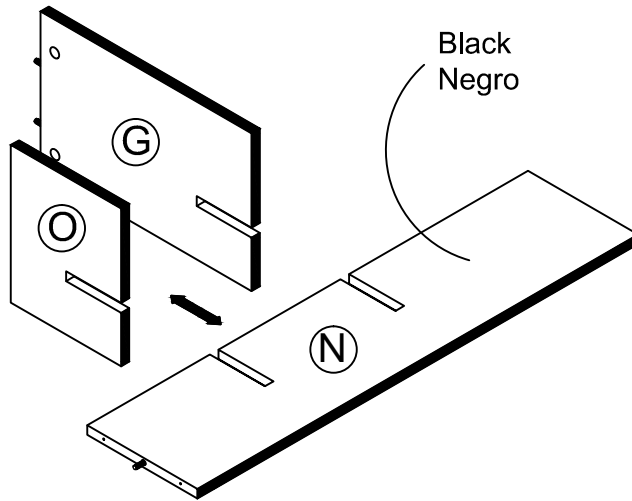
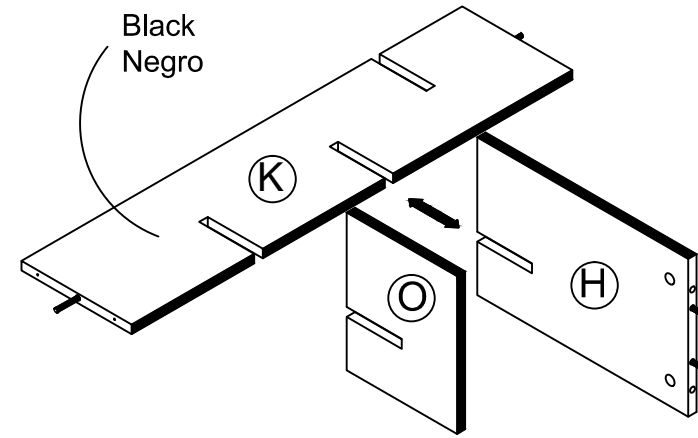
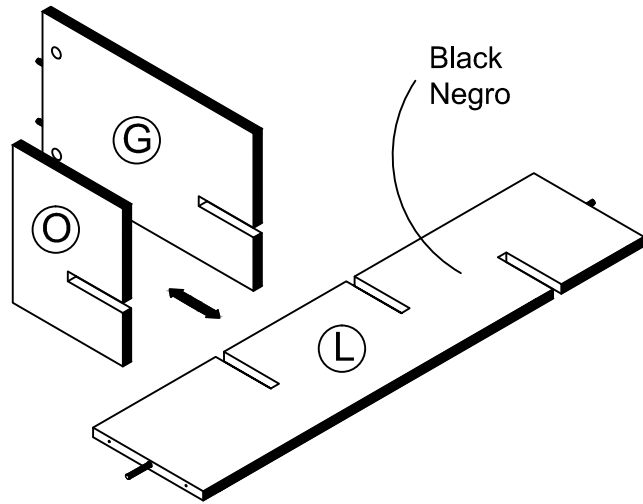

# 14

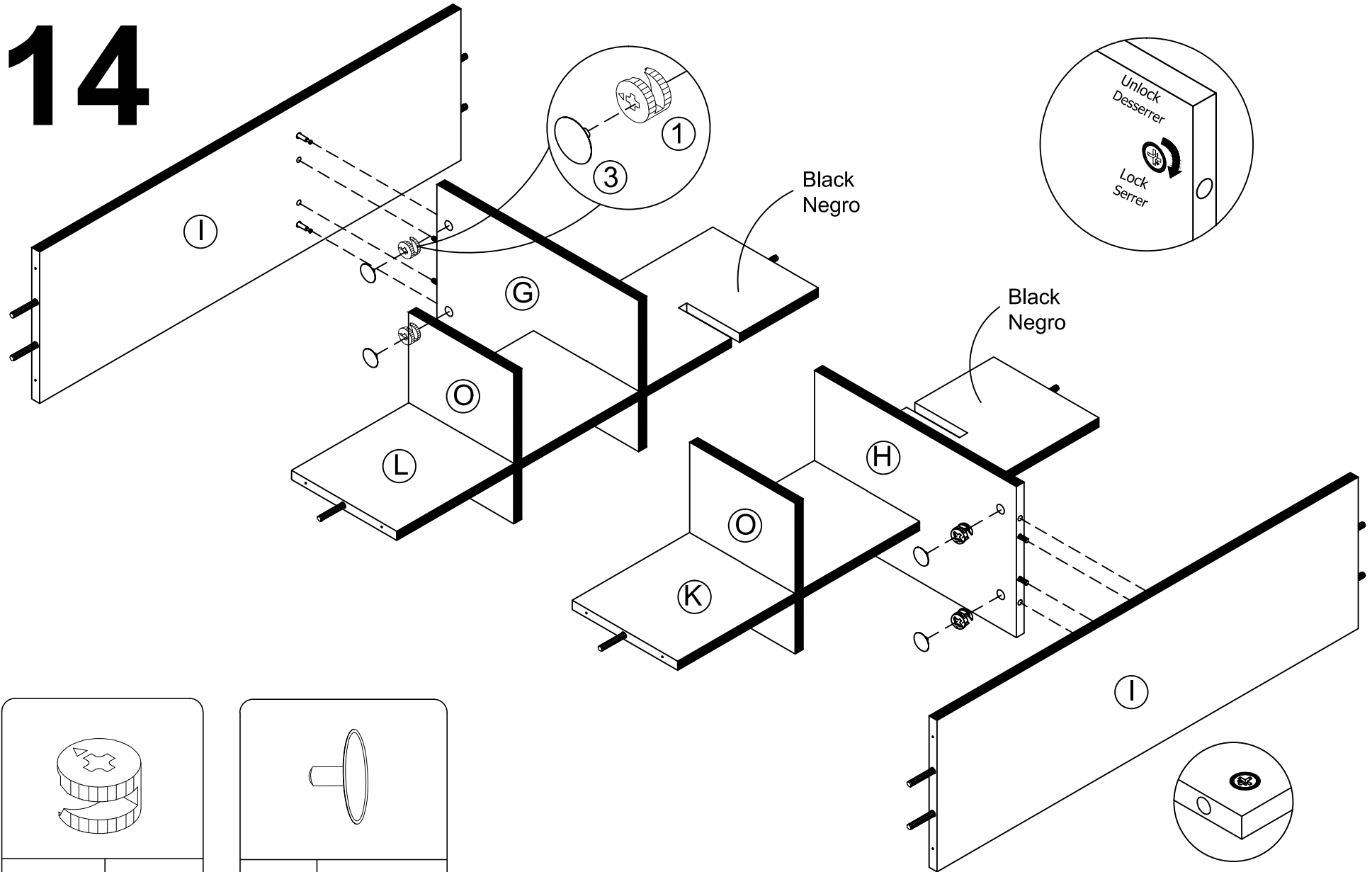

①	x 4

③	x 4

# 15

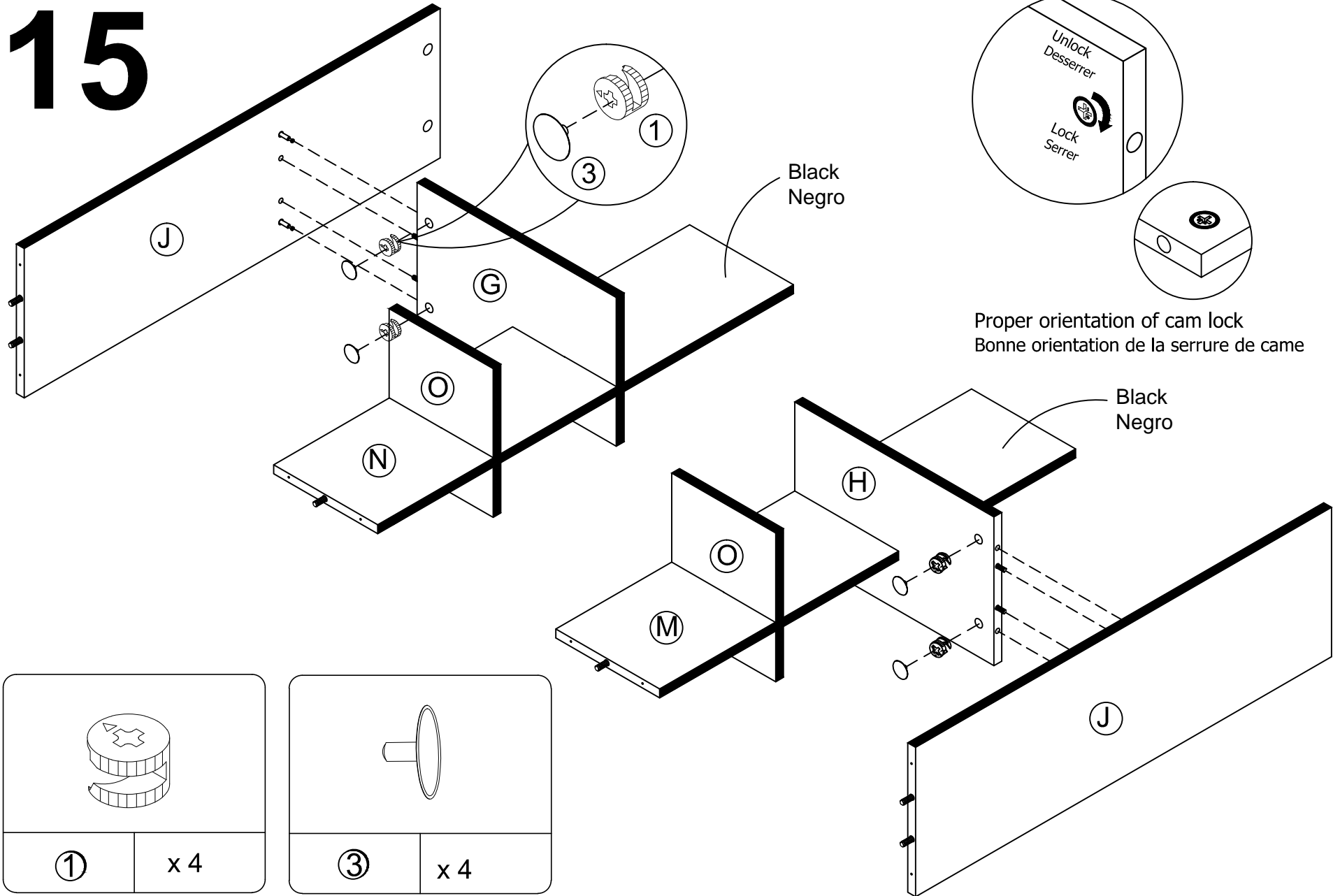

# 16

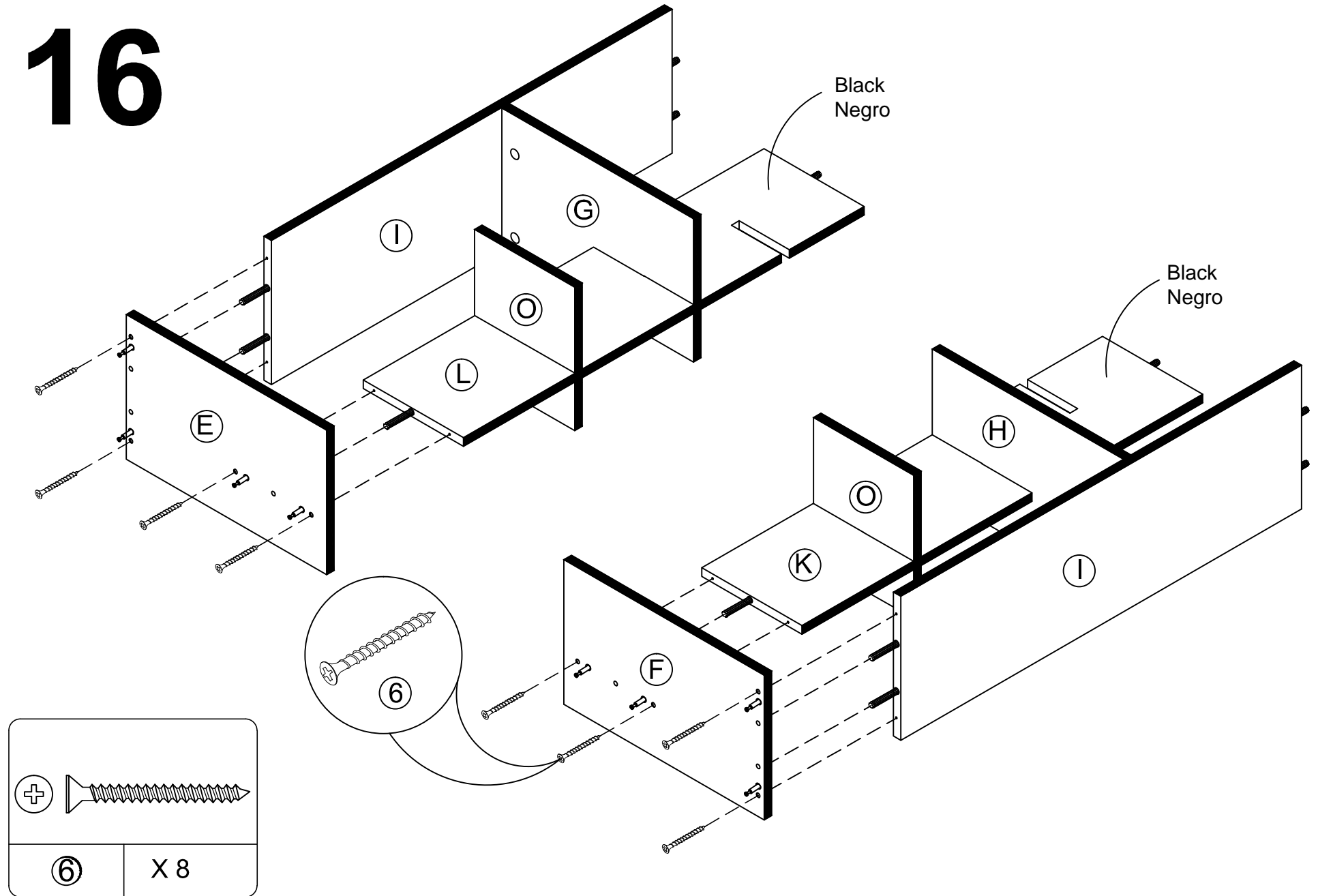

# 17

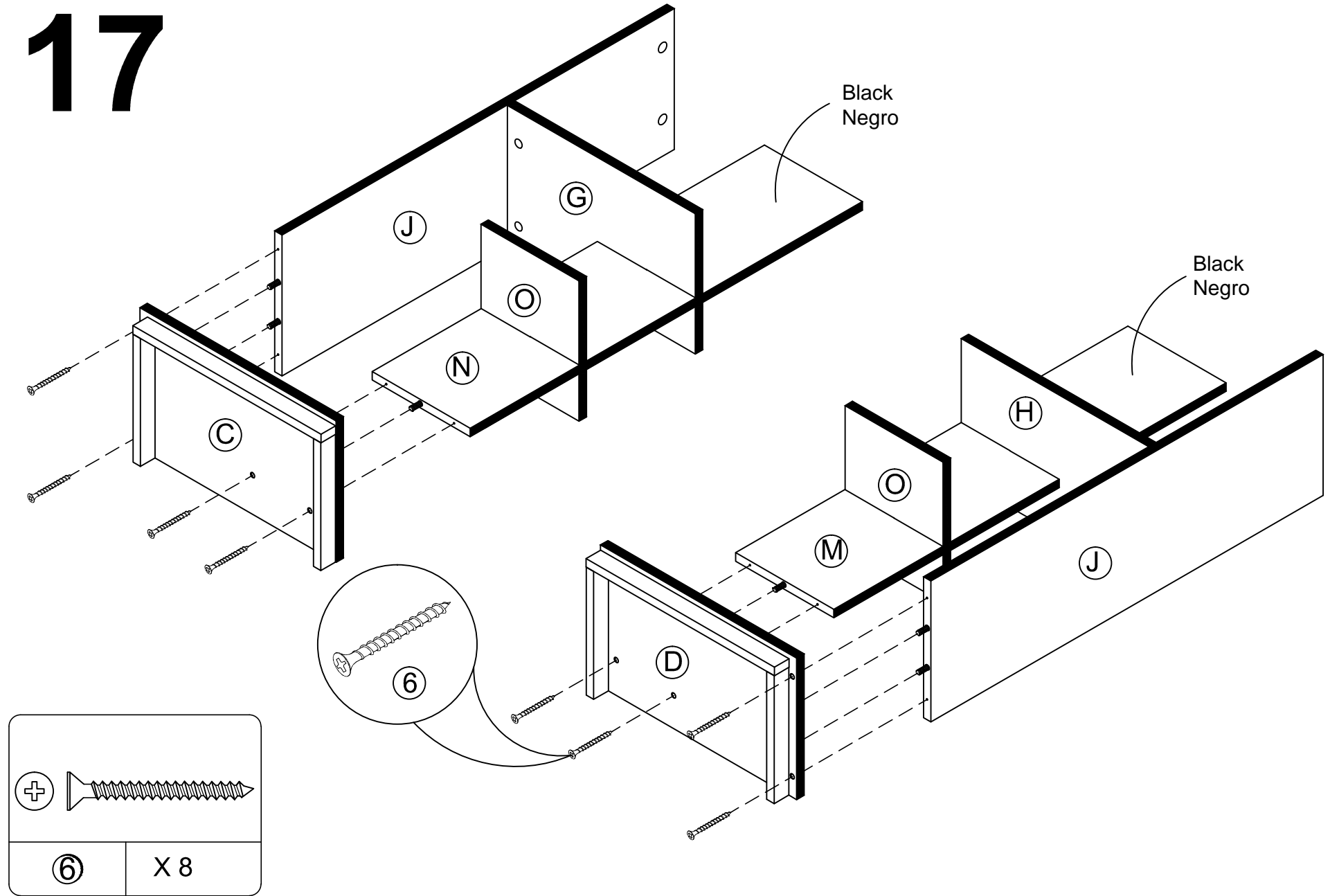

# 18

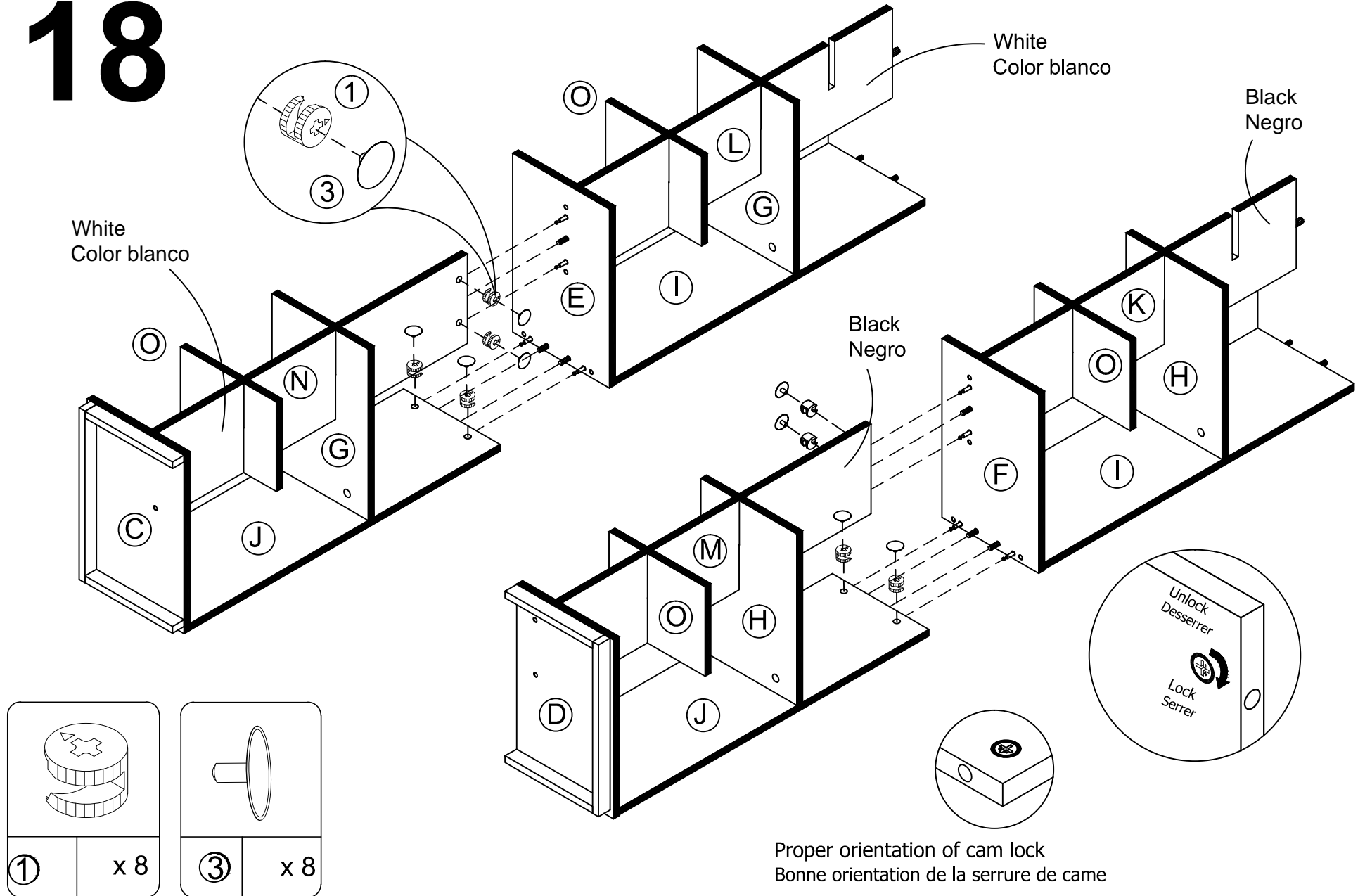



# 19

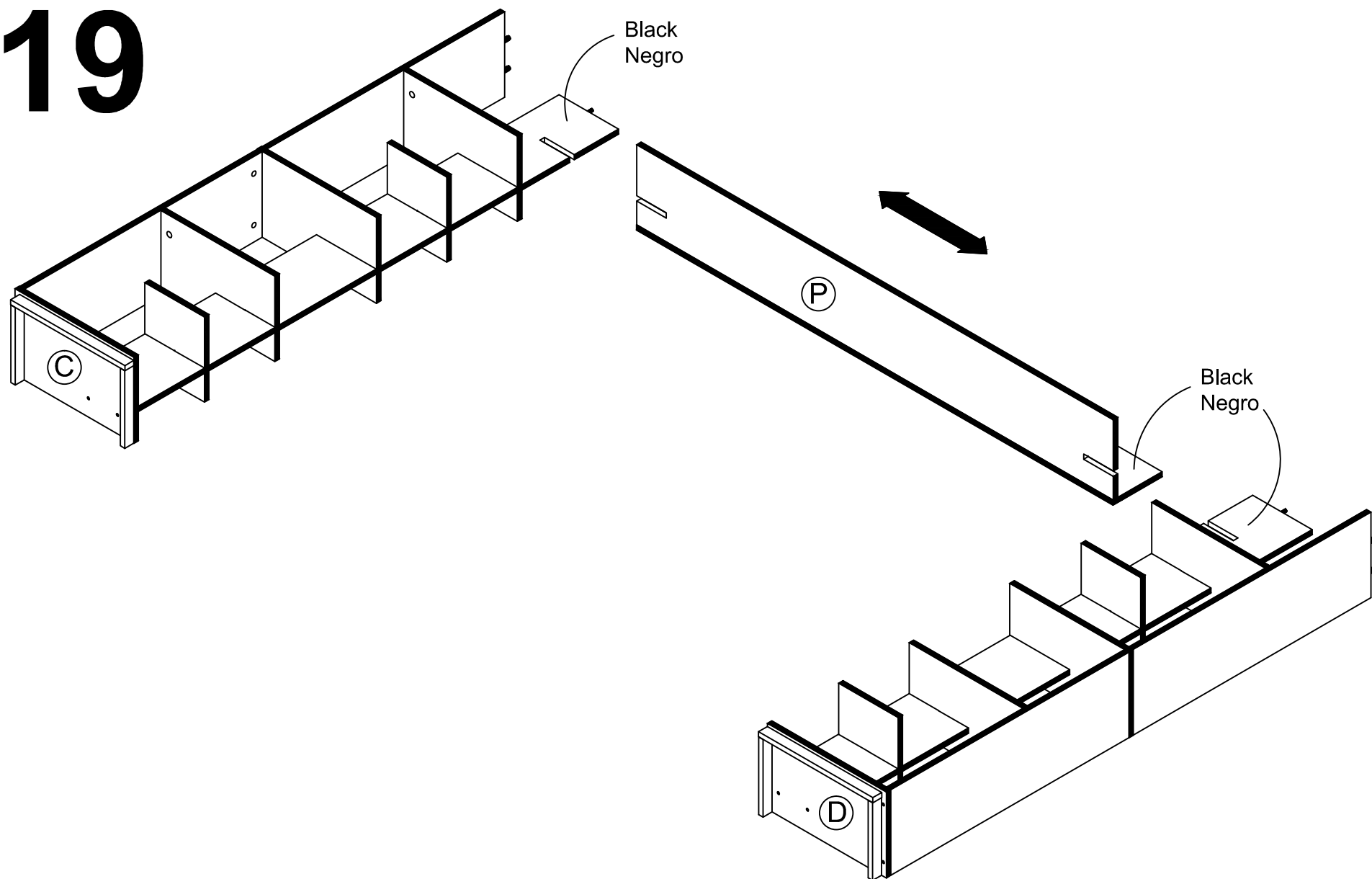

# 20

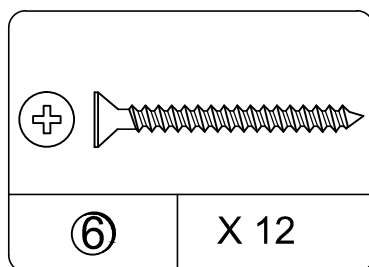
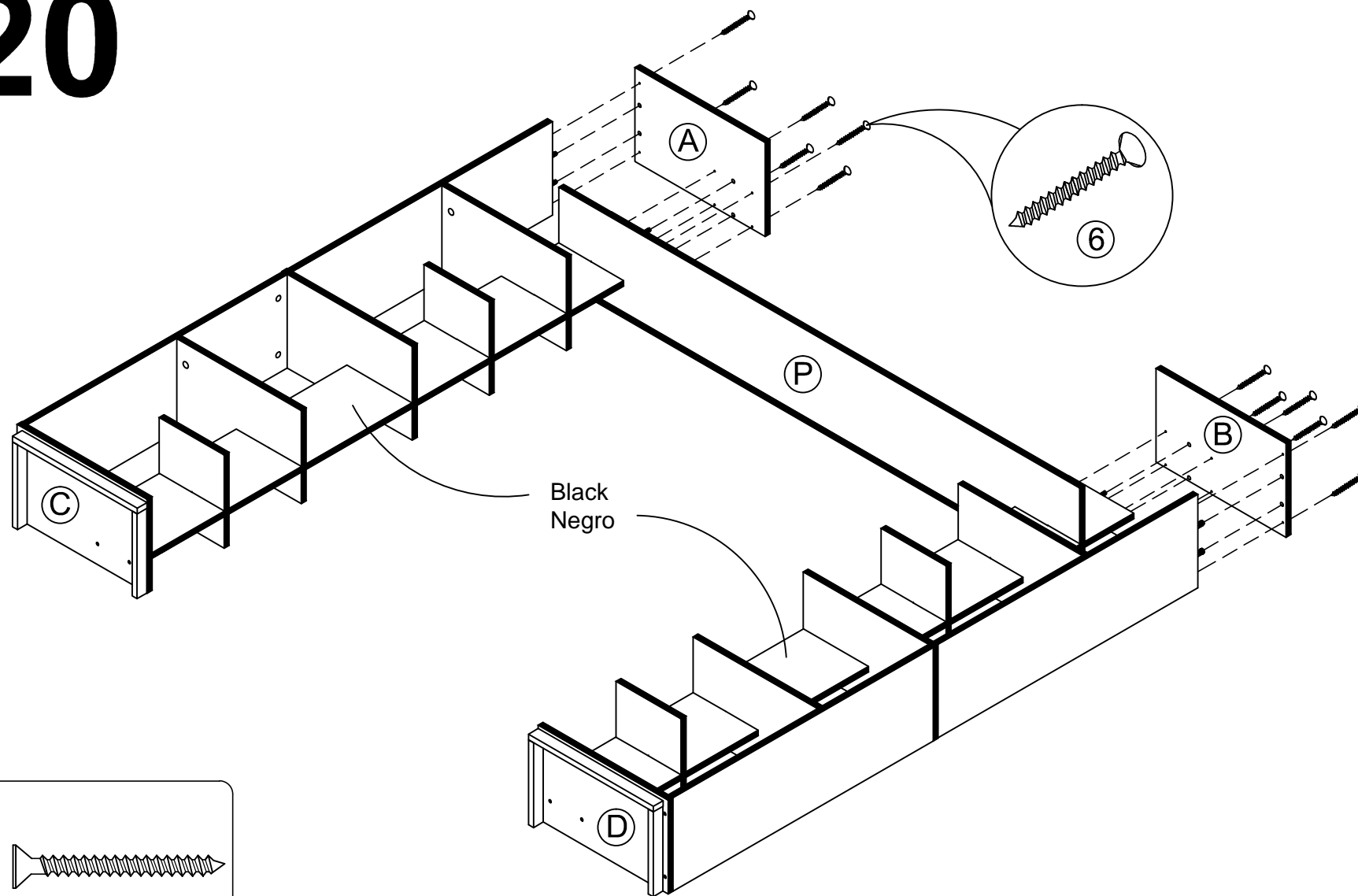

# 21

Back panel of TV stand also has two colors, white or black as the front color can be achieved by replacement.

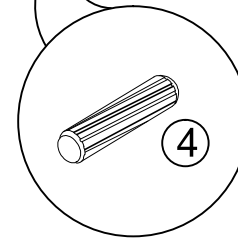
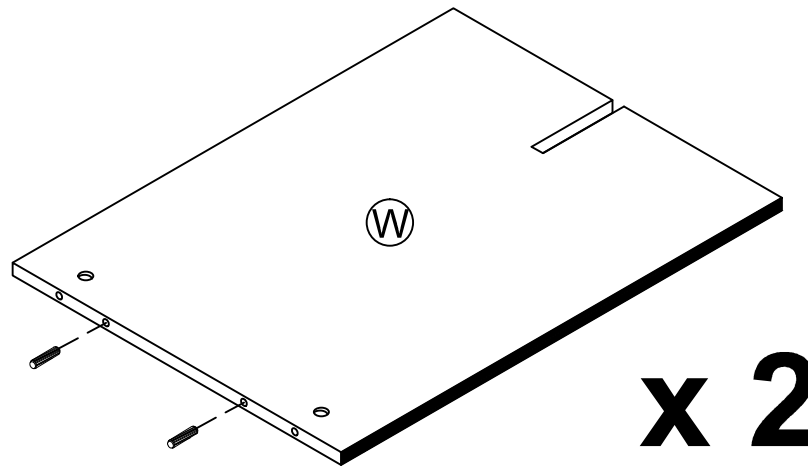
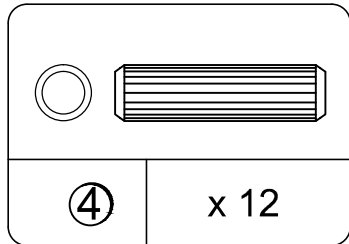
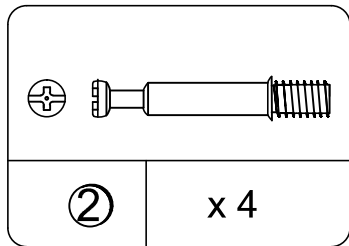
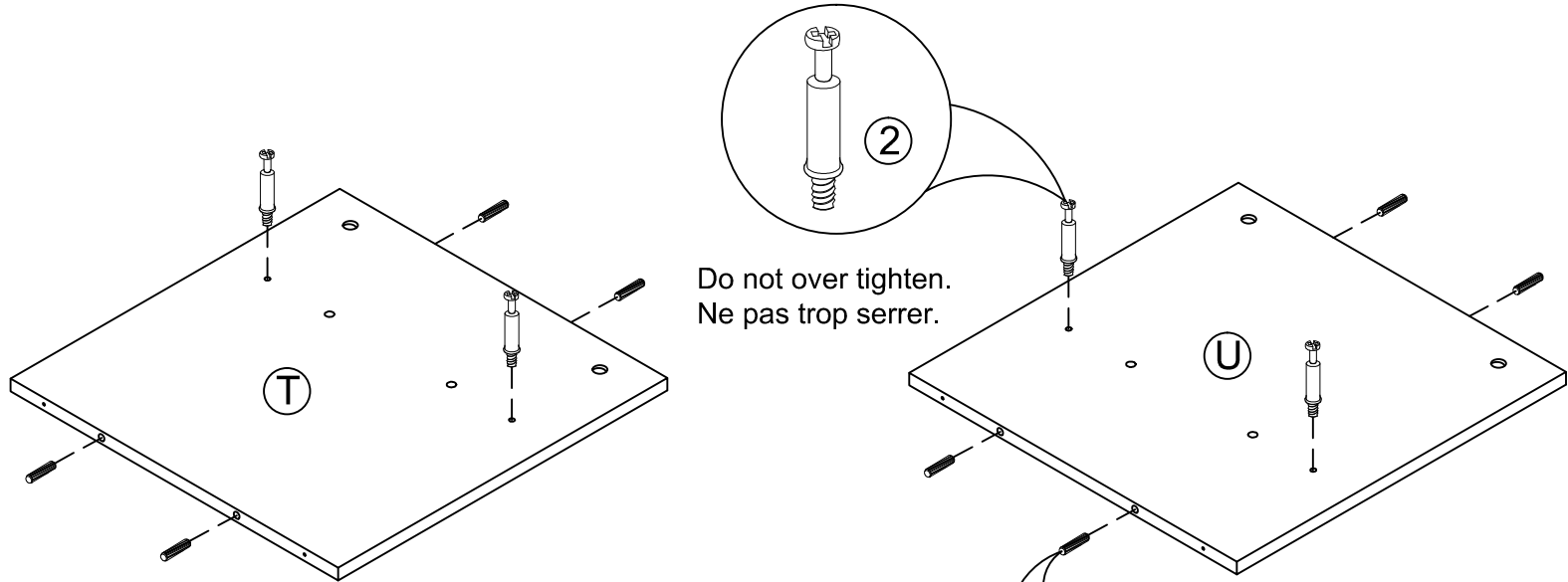

# 22

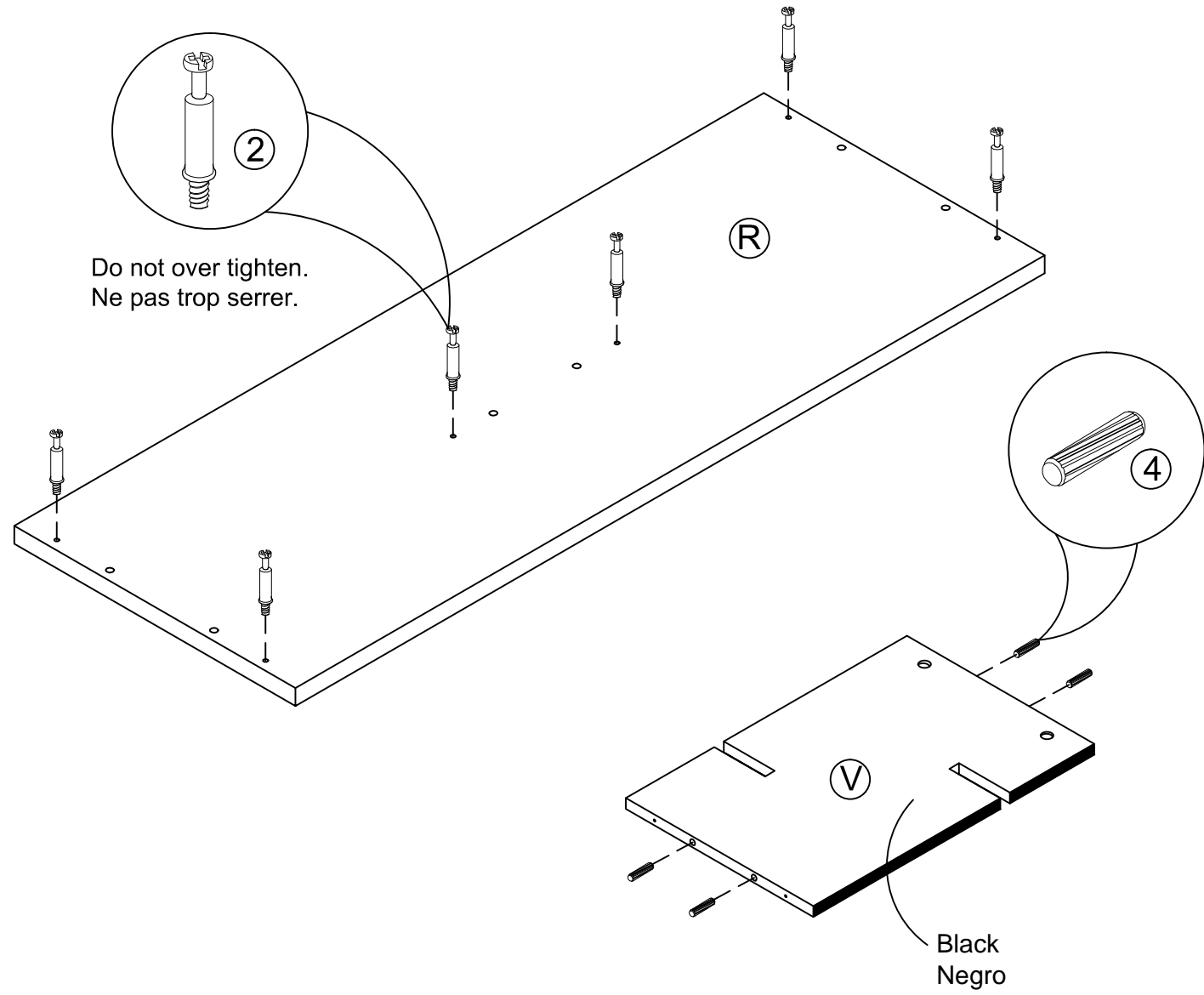

②	x 6

④	x 4

# 23

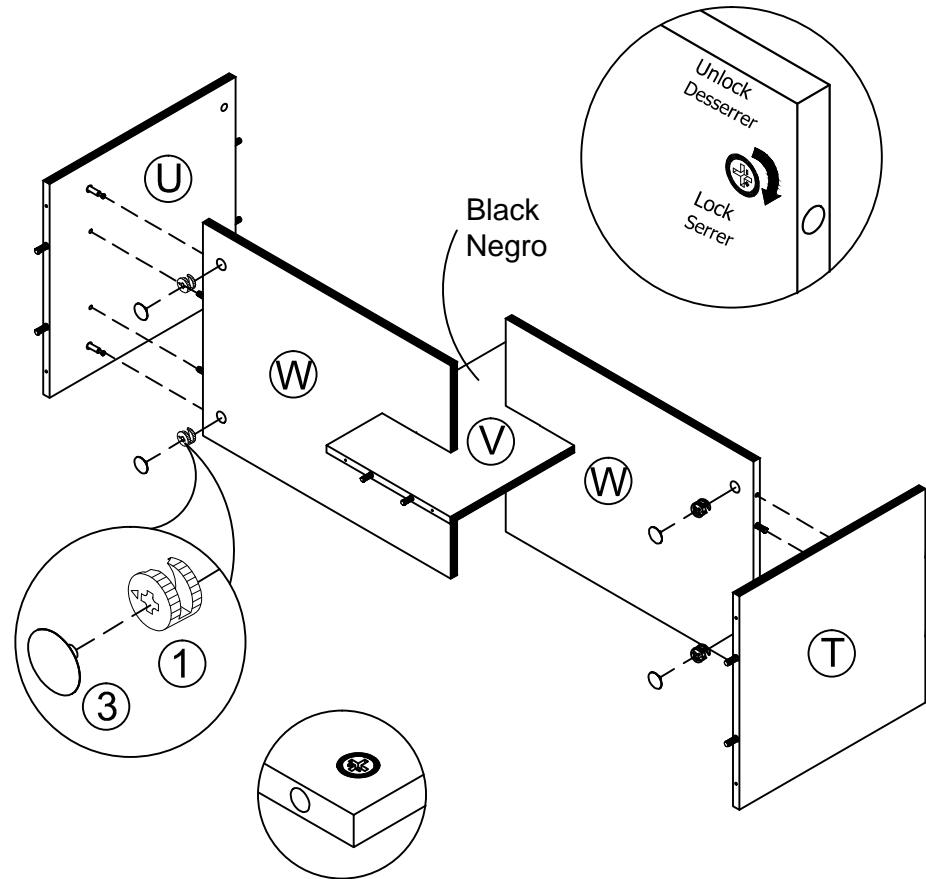
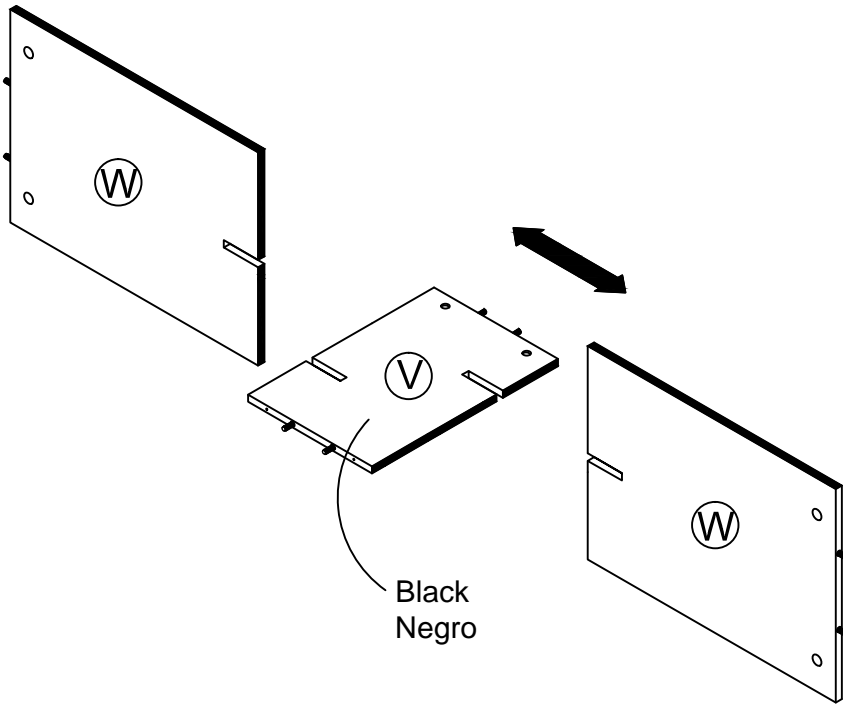

Proper orientation of cam lock  
Bonne orientation de la serrure de came

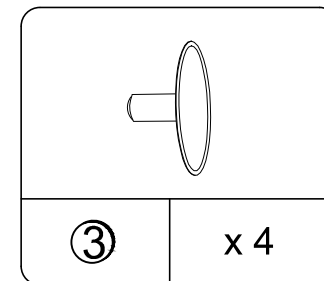
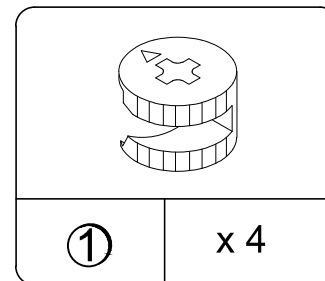

# 24

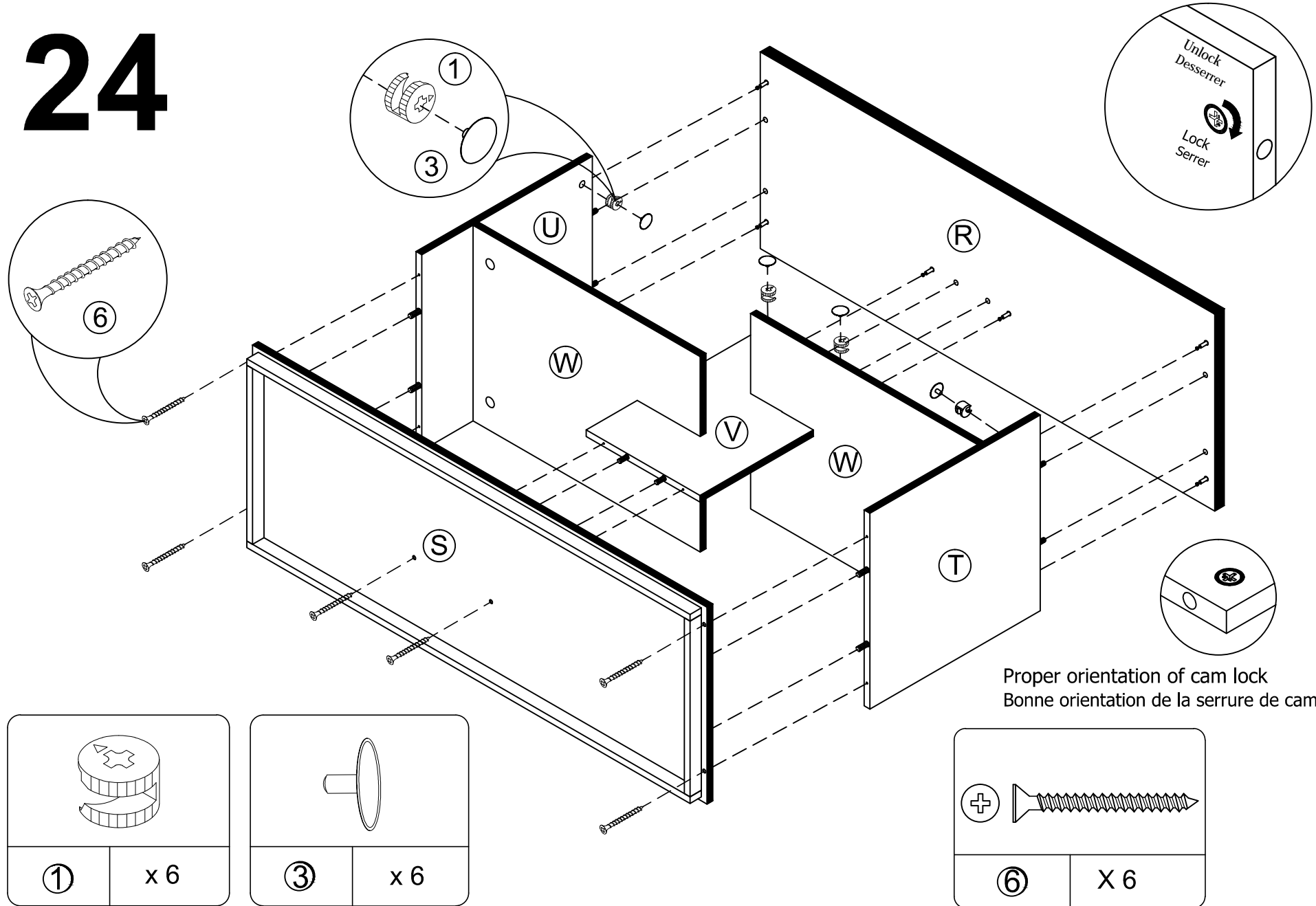

# 25

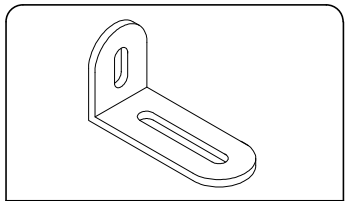

⑦

X 2

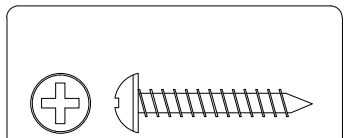

⑧

x 2

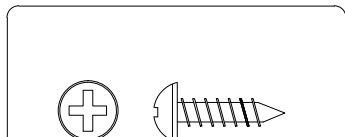

⑨

x 2

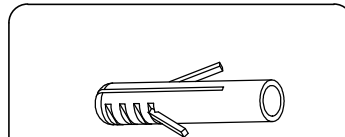

⑩

X 2

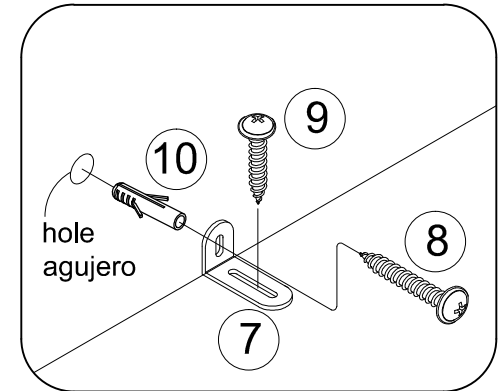
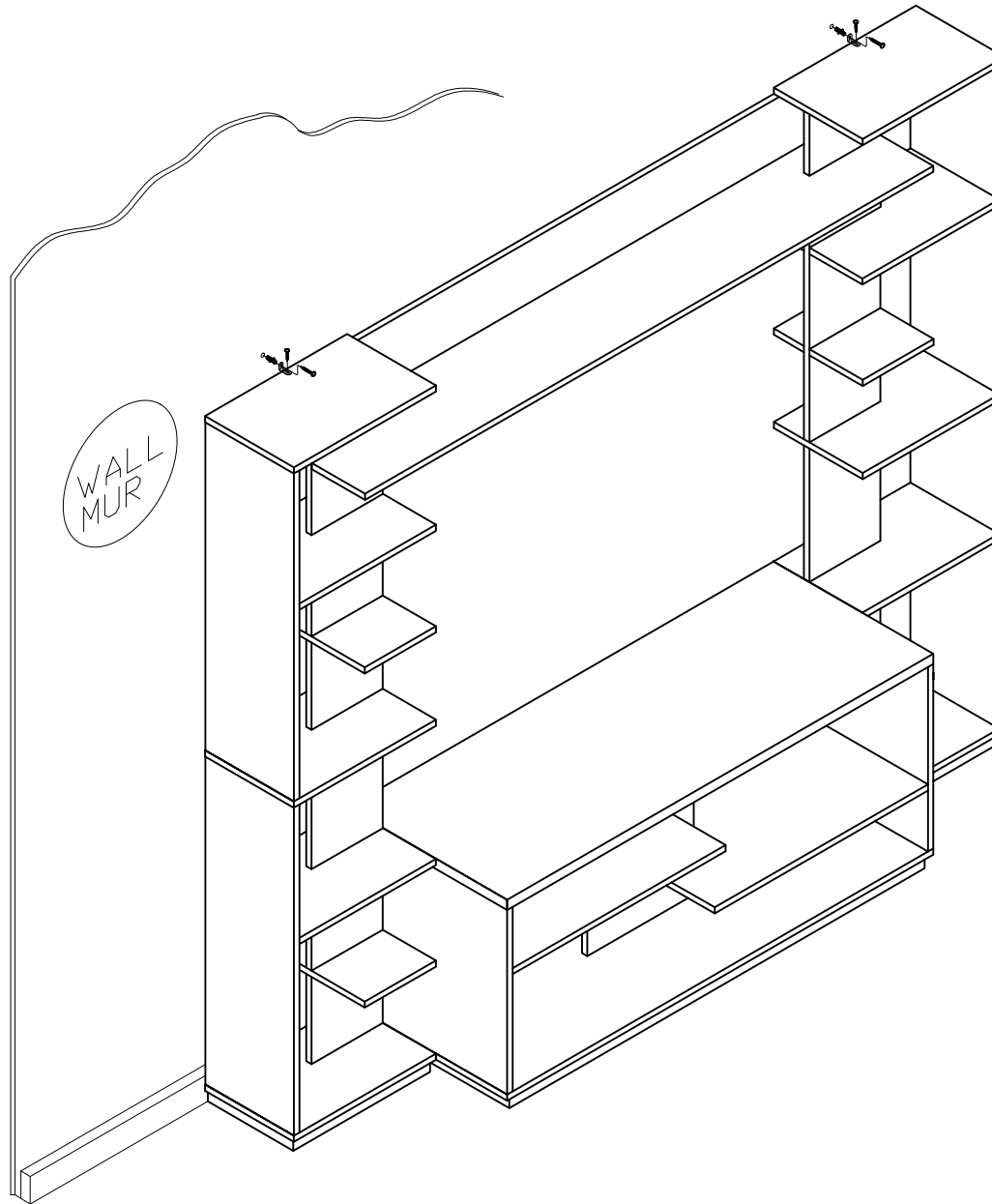

Drill a 5mm diameter hole (3/16") in the wallboard. Tap the wall anchor(10) into the hole until it is flush.

Percez un trou de 5mm de diamètre (3/16") dans le mur. Enfoncez l'ancrage mural (10) dans le trou jusqu'à ce qu'il soit affleurant contre le mur.

**▲ Warning**  
This unit must be anchored to a stud or wall, as shown. Failure to do so could cause severe injury.

**▲ AVERTISSEMENT:**  
Ce meuble doit être ancré à un montant ou au mur comme montré, sinon des blessures graves peuvent survenir.

# 26

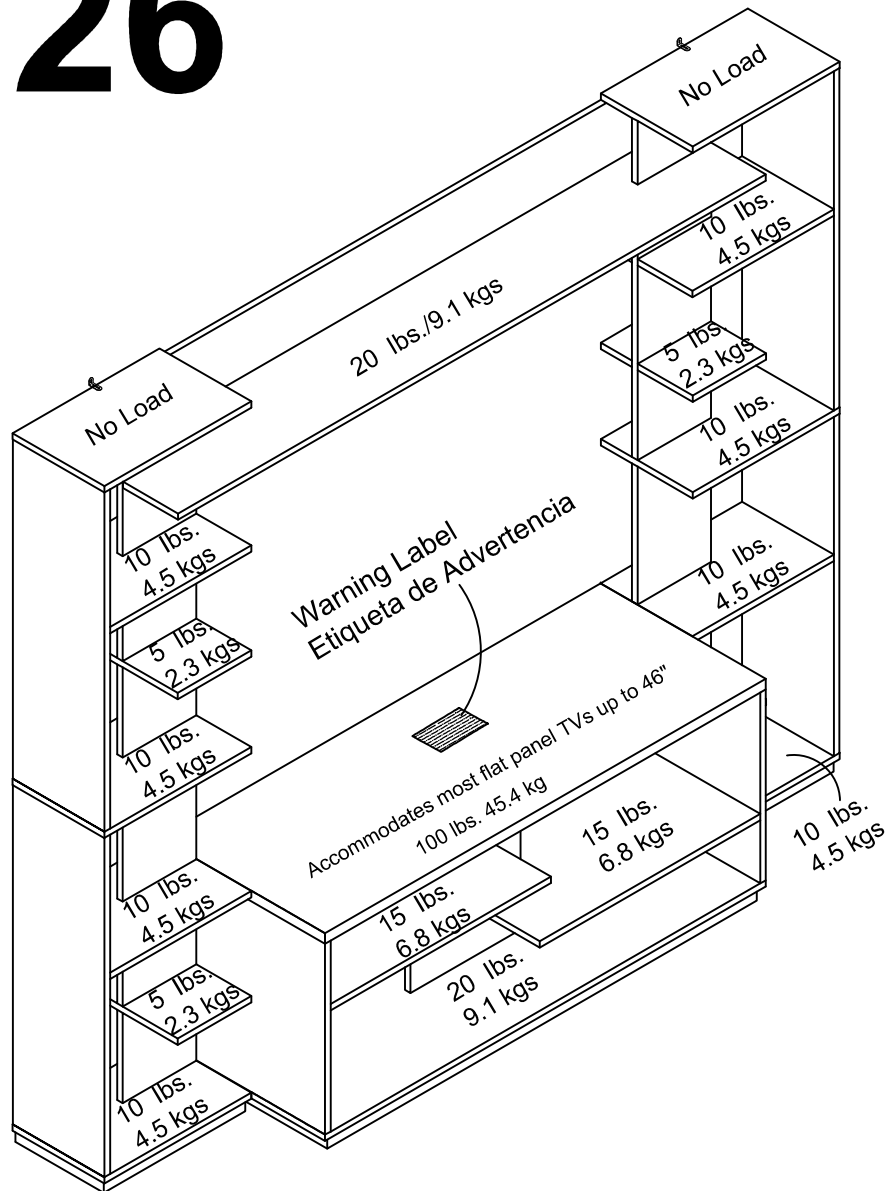

## WEIGHT LIMITS: LIMITES DE POIDS :

This unit has been designed to support the maximum loads shown.

Exceeding these load limits could cause sagging, instability, product collapse, and/or serious injury.

Cette unité a été conçue pour supporter les charges maximum montrées.

Le dépassement de ces limites de charge pourrait causer l'affaissement, l'instabilité, l'effondrement du produit, et/ou des blessures graves.

### ▲ WARNING

Please make sure that all objects are removed before moving the assembled unit.

### ▲ AVERTISSEMENT

Veuillez vous assurer d'enlever tous les objets sur le meuble avant de le déplacer.

Enjoy Your Furniture  
Profitez de votre meuble