



12x12 SunShed Garden Shed

Revision #15

November 24, 2014



Thank you for purchasing a 12x12 SunShed Garden Shed from Outdoor Living Today. Please take the time to identify all the parts prior to assembly.

Safety Points and Other Considerations
Our products are built for use based on proper installation and normal residential use, on level ground. Please follow the instruction manual when building your shed and retain the manual for future maintenance purposes.

Some of the safety and usage measures you may wish to consider include:

- snow load ratings vary by geographical location. If heavy or wet snowfall occurs, it is advisable to sweep the snow off the roof(s).
- if the product is elevated, any structural and building code requirements are solely the customer's responsibility, and should be abided by.
- in high or gusty wind conditions it is advisable to keep the structure securely grounded.
- have a regular maintenance plan to ensure screws, doors, windows and parts are tight.

Customer agrees to hold Outdoor Living Today free of any liability for improper installation, maintenance and repair of any of our products.

In the event of a missing or broken piece, simply call the Outdoor Living Today Customer Support Line @ 1-888-658-1658 within 30 days of the delivery of your purchase. It is our commitment to you to courier replacement parts, free of charge, within 10 business days of this notification. Replacement parts will not be provided free of charge after the 30 day grace period.

**Thank you for purchasing our 12x12 Sunshed Garden Shed.
Please take the time to identify all the parts prior to assembly.**

A. Floor Section

- 3 - 45 1/2" x 75" - Floor Joist Frames (Interior Joist Unattached)
- 3 - 45 1/2" x 66 1/2" - Floor Joist Frames (Interior Joists Unattached)
- 6 - 1 1/2" x 3 1/2" x 72" - Floor Joists
- 6 - 1 1/2" x 3 1/2" x 63 1/2" - Floor Joists
- 3 - 45 1/2" x 75" - Floor Plywood
- 3 - 45 1/2" x 66 1/2" - Floor Plywood
- 10 - 1 1/2" x 3 1/2" x 76 1/2 & 60" - Floor Runners

B. Wall Section

Main Wall Panels

- 4 - 45 1/2" x 75" - Solid Wall Panels
- 4 - 1 1/2" x 2 1/2" x 45 1/2" Bottom Wall Plates
- 4 - 45 1/2" x 75" - Window Wall Panels
- 3 - 45 1/2" x 75" - Double Window Walls
- 1 - 12" x 73" - Narrow Wall Panel
- 2 - 45 1/2" x 9" - Wall Extensors
- 2 - 46 1/4" x 9" - Angled Left Wall Extensors
- 2 - 46 1/4" x 9" - Angled Right Wall Extensors

Window Inserts

- 6 Fixed Windows (sides)
- 4 Functional Windows

Door, Door Jamb, Header & Door Stops

- 1 - 1 1/2" x 3" x 73" - Vertical Door Jamb
- 1 - 2" x 3" x 45 1/2" - Door Header (Dado)
- 2 - 1/2" x 2 1/2" x 72" - Interior Vertical Door Stops
- 1 - 1/2" x 2 1/2" x 36" - Interior Horizontal Door Stop
- 1 - 31 1/2" x 72" - Dutch Door - 2pcs (42" and 30" high)

Gable Walls

- 2 - Left Hand Gables- Triangular shaped
- 2 - Right Hand Gables- Triangular shaped

Top Wall Plates

- 4 - 3/4" x 2 1/4" x 65 3/4" - Sides- 22 1/2 degree cut on edge
- 4 - 3/4" x 2 1/2" x 70 3/4" - Front and Rear - Angled on end

C. Rafter Section

- 18 - 1 1/2" x 3 1/2" x 81 1/8" - Rafters - angled on both ends
- 2 - 3/4" x 4 1/2" x 52 1/2" - Ridge Boards
- 2 - 3/4" x 4 1/2" x 84" - Ridge Boards
- 4 - 1/2" x 4 1/2" x 68 1/4" - Soffits
- 2 - 3/4" x 3 1/2" x 56 1/2" - Support Beam
- 2 - 3/4" x 3 1/2" x 75" - Support Beam
- 10 - 5/8" x 6" x 6" - Plywood Support Beam Connector Plates
- 3 - 3/4" x 3 1/2" x 72" - Gussets (angle cut on both ends)

D. Roof Section

- 1 - Left Side - Shingle Overhanging Battens (Long)
- 1 - Right Side - Shingle Overhanging Battens (Long)
- 1 - Center - Shingles flush with Battens (Long)
- 1 - Left Side - Shingle Overhanging Battens (Short)
- 1 - Right Side - Shingle Overhanging Battens (Short)
- 1 - Center - Shingles flush with Battens (Short)

- 12 - 3/4" x 3/4" x 48" - Lexan Support Cleats
- 3 - 1/2" x 2 1/2" x 48" - Mid Ridge Caps for Lexan
- 2 - 1/2" x 5 1/2" x 48" - Outside Ridge Caps for Lexan
- 2 - 1/2" x 3 1/2" x 48" - Center Ridge Caps for Lexan
- 6 - 20 1/4" x 48" - Lexan Panels

E. Miscellaneous Section

Bottom Skirting

- 12 - 1/2" x 4 1/2" x 45 1/4" - Bottom Skirting

Corner & Wall Trim

- 4 - 1/2" x 2 1/2" x 75" - Filler Trim
- 4 - 1/2" x 4 1/2" x 82" - Vertical Corner Trim
- 5 - 1/2" x 2 1/2" x 87" - Vertical Trim
- 8 - 1/2" x 2 1/2" x 79" - Vertical Trim
- 2 - 1/2" x 4 1/2" x 58 1/2" - Horizontal Gable Trim (Left) -angled
- 2 - 1/2" x 4 1/2" x 58 1/2" - Horizontal Gable Trim (Right) -angled
- 1 - 1/2" x 2 1/2" x 32" - Horizontal Door Trim (above Door)
- 1 - 1/2" x 2 1/2" x 8" - Horizontal Narrow Wall Trim (above Wall)

Facia Trim

- 2 - 3/4" x 3 1/2" x 82 1/8" - Angle Cut Front/Rear Facia Trim (L)
- 2 - 3/4" x 3 1/2" x 82 1/8" - Angle Cut Front/Rear Facia Trim (R)
- 4 - 3/4" x 3 1/2" x 72" - Side Facia
- 4 - Facia Detail Plates -Sides - (2@3 1/2 & 2@4 1/2" High)
- 2 - Pentagon Detail Plates (front and back)
- 4 - Triangular Corner Gable Trim Pieces (2 L / 2R)

Filler Shingles (5 1/2" wide)

- 14 - Long Shingles
- 4 - Short Shingles

Ridge Caps

- 22 - Cedar Shingle Roof Ridge Caps

Flower Boxes & Window Trim

- 7 - Flower Box Kits (Assembly Manual & Hardware found in each Kit)

- 4 Reg Window Trim Pkgs: 1 x 24 1/16" Top, 3 x 23" Bottom & Sides
- 6 Sm. Window Trim Pkgs: 1 x 20 1/4" Top, 2 x 21 7/16" Sides, 1 x 19 1/4" Bottom

Potting Shelves

- 3 - 16" x 45" - Long Potting Shelves
- 1 - 16" x 41" - Short Potting Shelf
- 8 - 1 1/2" x 2 1/2" x 36" - Potting Shelf Legs

****Miscellaneous Pieces**

- 1 pc - Spare Wall Siding
- 2 pcs - Spare Shingles- use to shim door, etc

12x12 SUNSHED HARDWARE SHEET

Hardware Kit (Provided)

Note: screws and nails shown actual size.

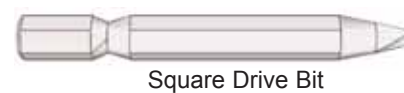

Tee Hinge x4



Pull Handle



Black Barrel Bolt



Simpson Strong Tie (Roof) x 8



Ridge Board Connector x 2



Silver Barrel Bolt



Silicon Caulking

Tools Required (Not Provided)



Hammer



Screw Gun/Drill



Tape Measure



Wood Clamp



Caulking Gun



Level



Pliers



Ladder



1/8" Drill Bits

Safety Equipment Required (Not Provided)



Safety Glasses



Work Gloves

A. Floor Section

Exploded view of all parts necessary to complete Floor Section. Identify all parts prior to starting.

Note, Floor Footprint is 136 1/2" deep x 141 1/2" wide.

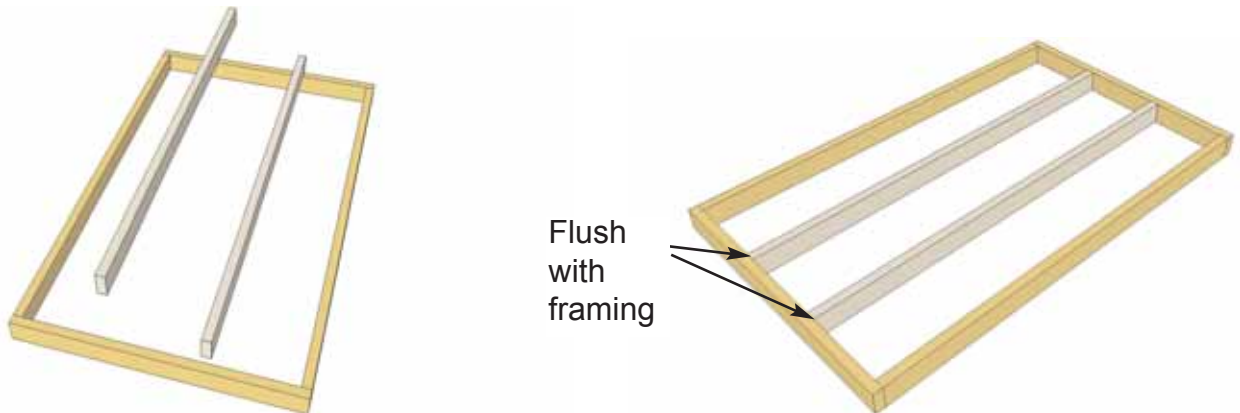
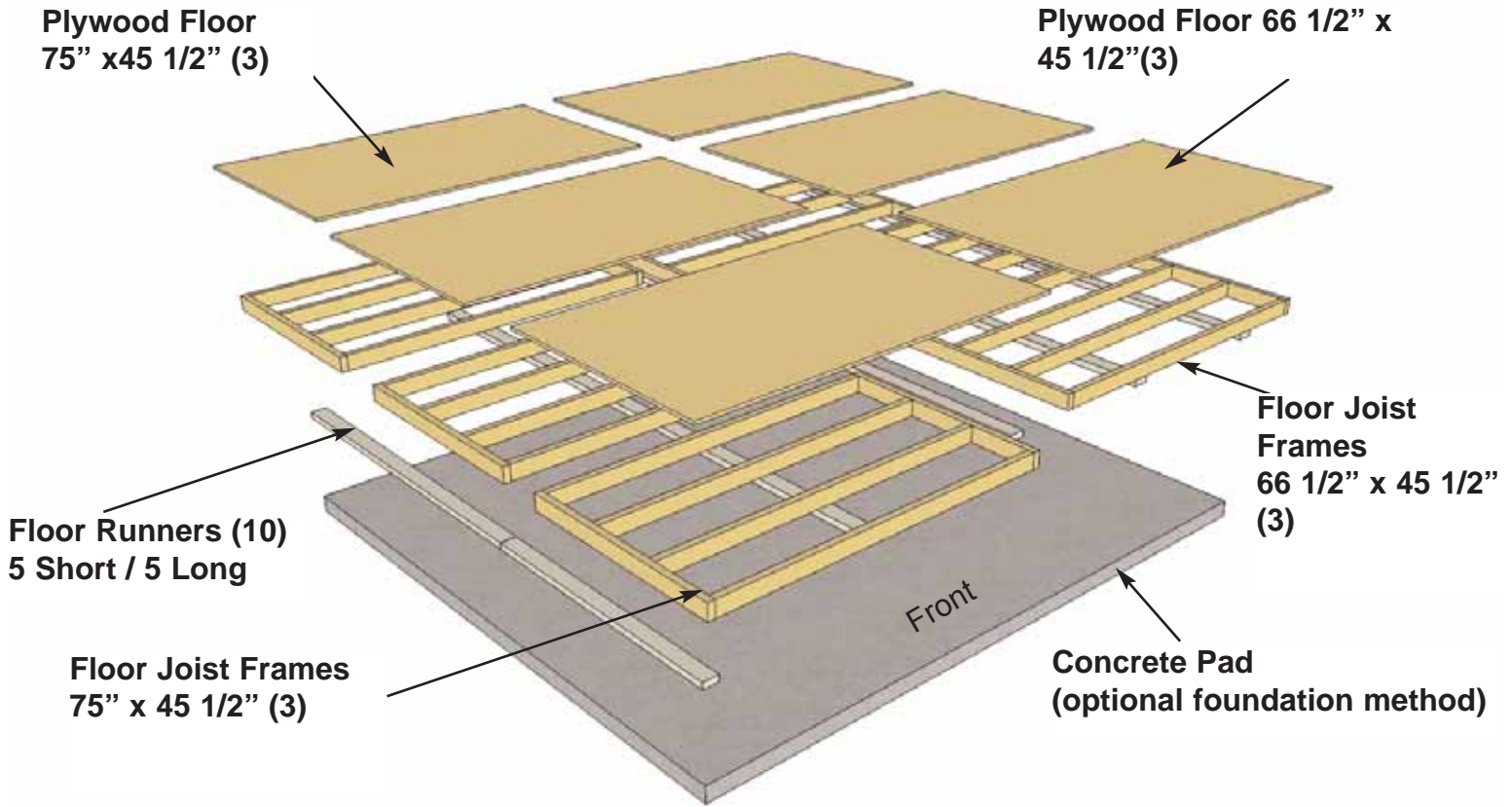

- 1.** Lay out all **Floor Joist Frames and Floor Joists** on ground as illustrated above. Position 72" Floor Joists in 75" frames and 63 1/2" Floor Joists in 66 1/2" frames. Position Joists equally in Floor Joist Frame. Position Joist so flush with framing.

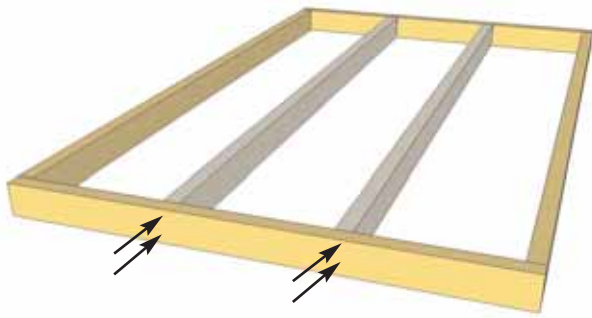

2. When correctly positioned, attach each Joist with 4 - 2 1/2" screws (2 per end). Complete all Floor Frame and Joist connections. You can find the Square Drive Bit for the screws in with the Hardware Kit Bag.

You can find the Square Drive Bit for the screws in with the Hardware Kit Bag.

66 1/2" long Floor Frame

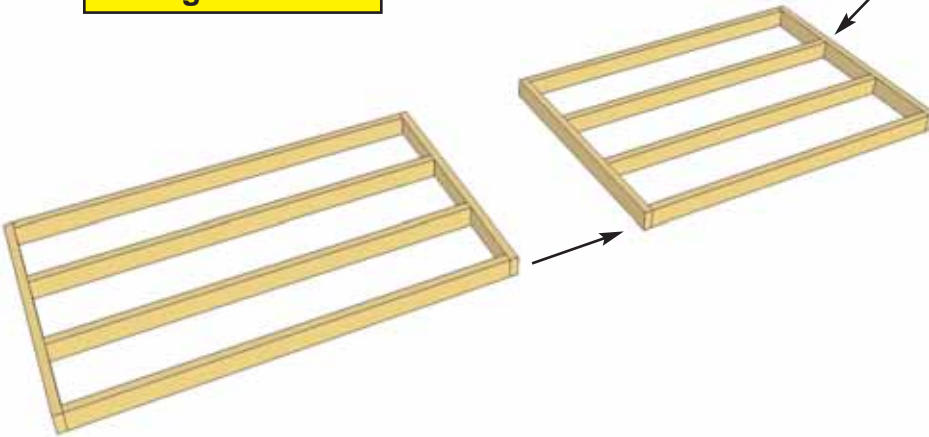

3. Lay out 66 1/2" and 75" long **Floor Joist Frames** and attach together with 6 - 2 1/2" screws. Complete all Long and Short Floor Frames now. (3 in total).

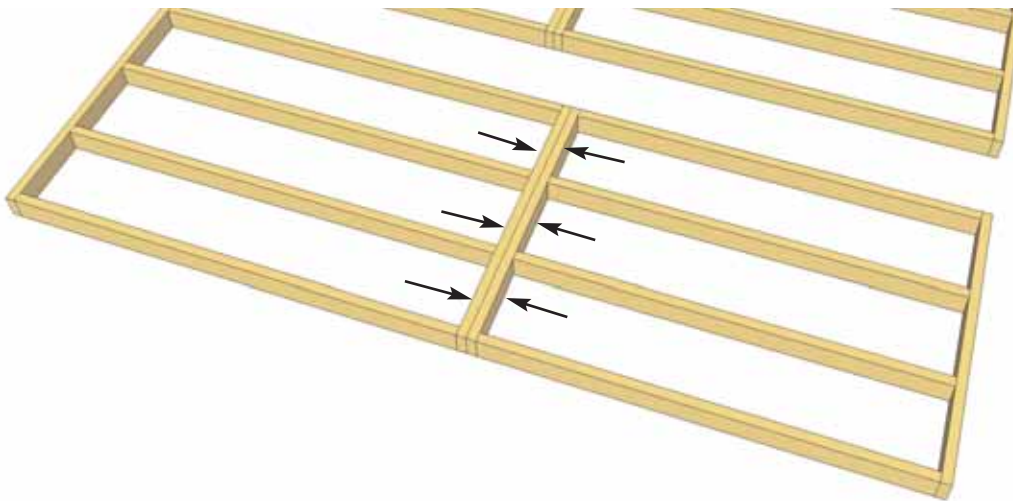

4. Now attach each completed section together with 16 - 2 1/2" screws as illustrated to the right.

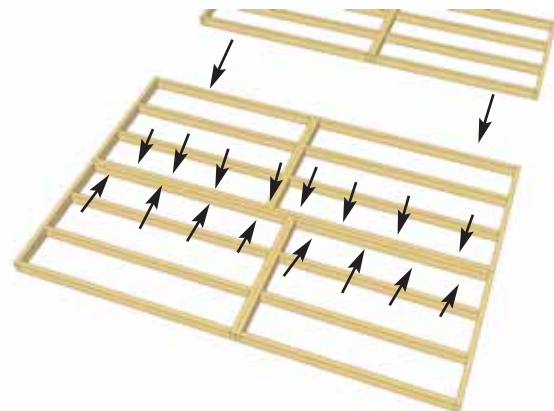

5. When completed, your floor footprint should be 136 1/2" deep x 141 1/2" wide.

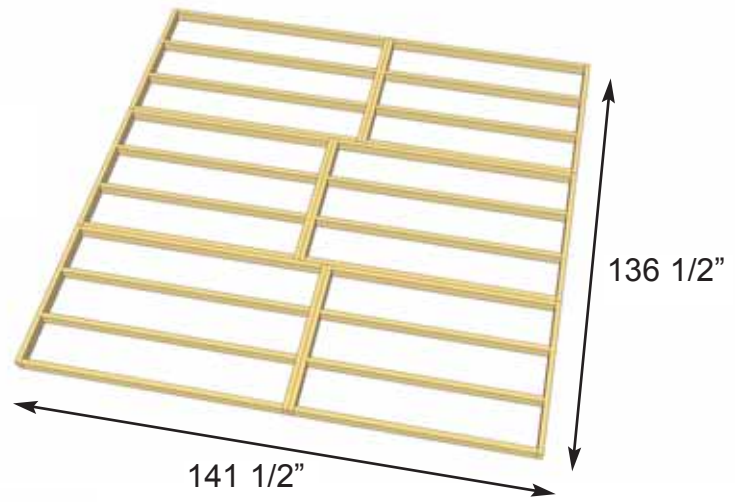

8. Attach **Floor Runners** to completed floor frame. There are 2 floor runners per 136 1/2" side and 5 completed runners in total. Use 6 - 2.5" screws per Runner.

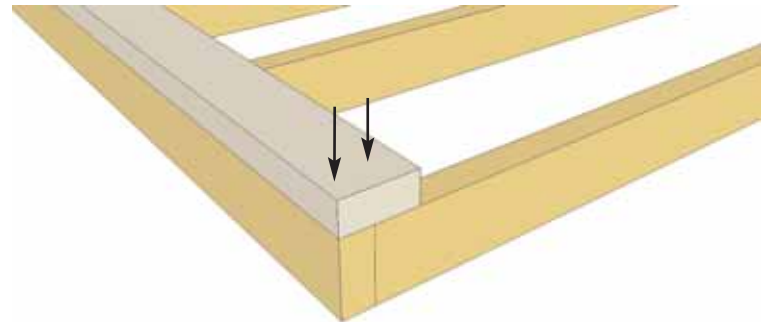

9. Make sure Runners are flush with outside and front and rear floor framing but not overhanging.



10. Complete all Floor Runners.

11. With Floor Runners attached, carefully flip the floor over and place on your foundation. **Caution-** you will need 2 people to assist you. Be careful when laying floor down not to bend or twist floor. When in place, level floor completely.

Foundations

Note: The floor will be flipped over and floor runners will sit on your foundation. It is important to note that having a level foundation is critical. Choosing a foundation will vary between regions. Typical foundations can be concrete pads or patio stones positioned underneath the floor runners.



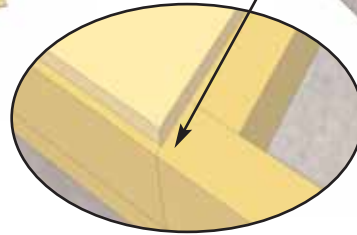
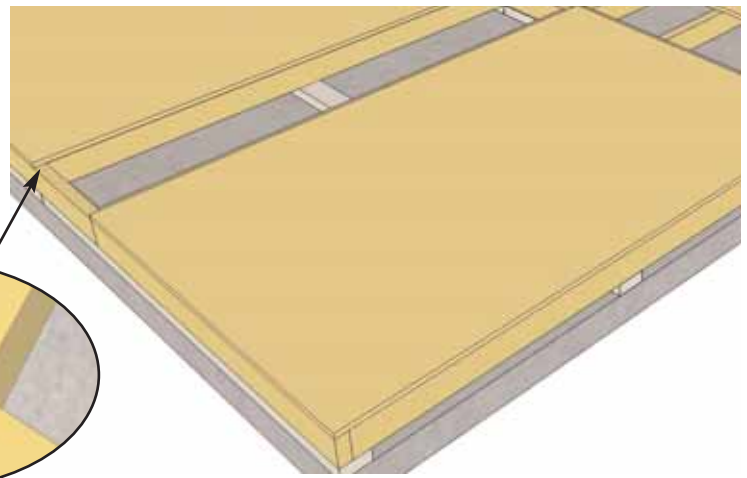
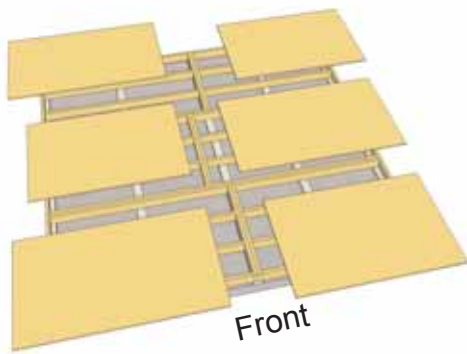

12. Position **Plywood Floor** pieces (6) on top of completed Floor Joists. Position **Plywood Floor** piece on top of completed Floor Joists. Plywood will sit slightly back from outside edge of Floor Joist Framing. When in correct position, attach with 1 1/4" screws. Use screws every 16". The Plywood is cut slightly smaller than floor framing. Keep plywood seams tight.

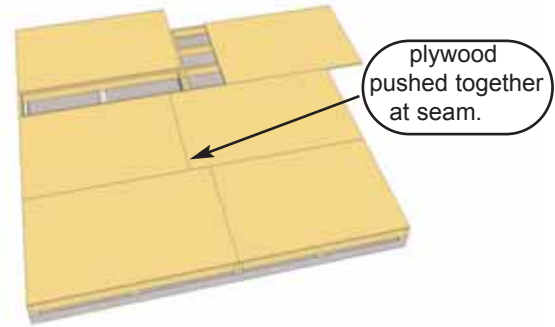

Hint: Use a chalk line to mark location of floor joists to determine screw placement.

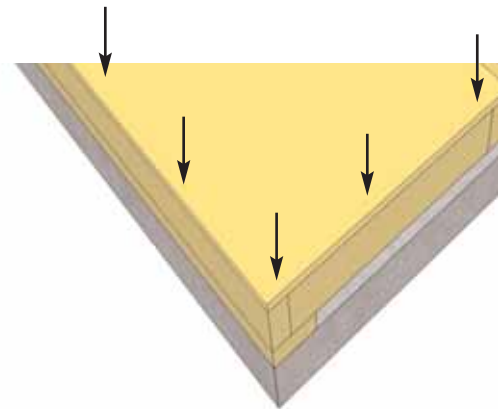
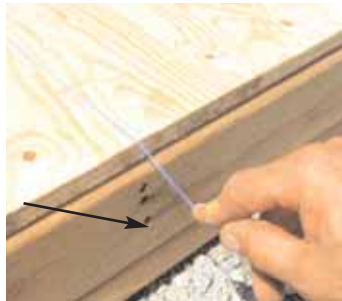

13. With Plywood positioned correctly on floor framing, attach with 1 1/4" screws. Use screws every 16".

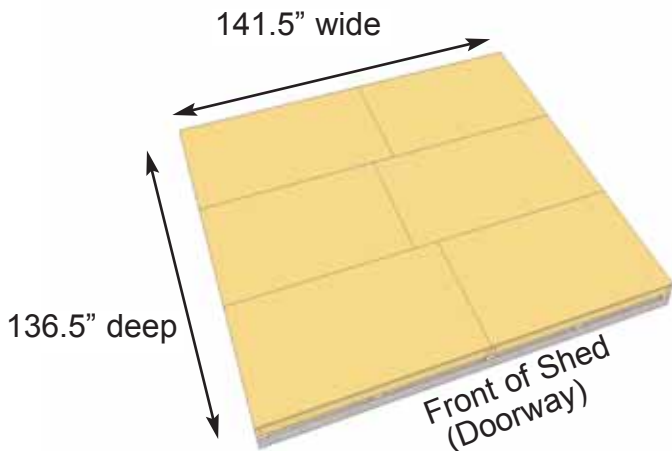

Important- Check to confirm that your floor is level prior to proceeding to the next step of wall assembly.

B. Wall Section

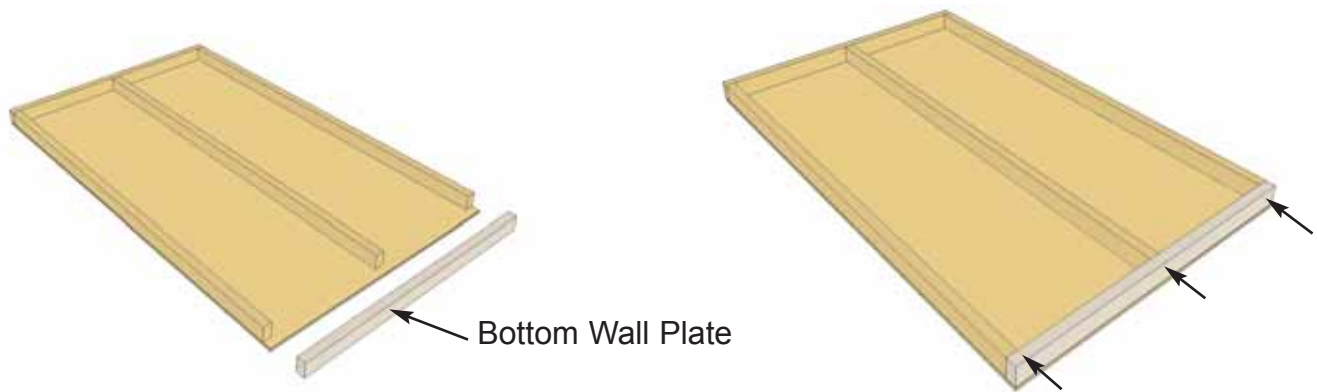

14. Starting with **Solid Wall Panels**, carefully lay panel face down. Position and attach **Wall Plate** to bottom of wall studs of each wall panel with 3 - 2 1/2" screws. Position so plates are flush with framing. Note, some Bottom Wall Plates may already be attached to some Solid Walls.

Important:

Make sure all walls are aligned in their upright position. If not, water may leak into your shed. Unsure if panel is facing up or down? check siding on window wall panel to match alignment.

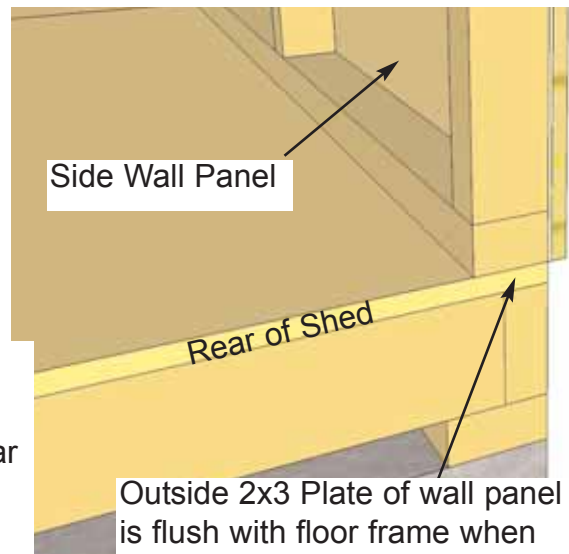
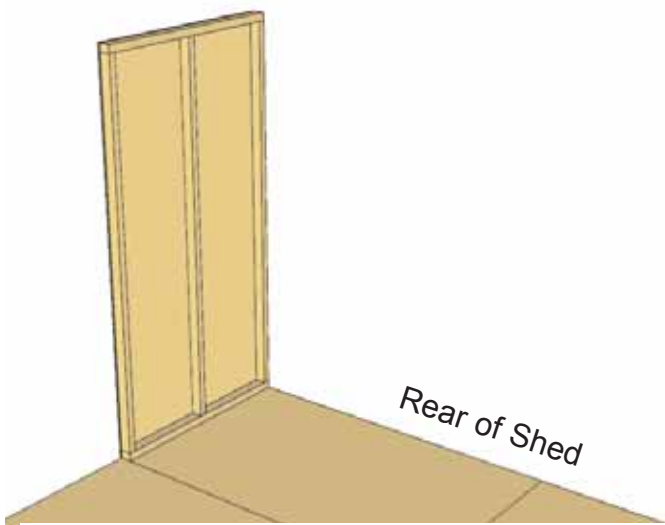

15. Starting at Rear Corner, position a Solid Wall Panel on top of plywood floor. Make sure panel is facing up. The side wall panels will sit flush with floor frame with the front and rear panels sandwiching between them.

Note: Siding will overhang the floor by approx. 1/2"



16. Locate **Window Inserts for both Regular and Narrow Double Walls**. Before installing, run a bead of caulking around window opening perimeter. Position window in cavity and secure with 8- 1 1/4" screws. Position Window Trim around window doing a dry run first and attach with 4- 1 1/4" finishing nails per piece. Trim Sizes = Reg. Window: 1 x 24 1/16" top, 3 x 23" sides & Bottom. Small Window: 1 x 20 1/4" top, 2 x 21 7/16" sides, 1 x 19 1/4" Bottom

17. Position rear Window Wall Panel into place on plywood floor. Butt both vertical wall studs of side and rear walls together and attach with 3 - 2.5" screws. Screw at the bottom, middle and top of stud to secure properly.

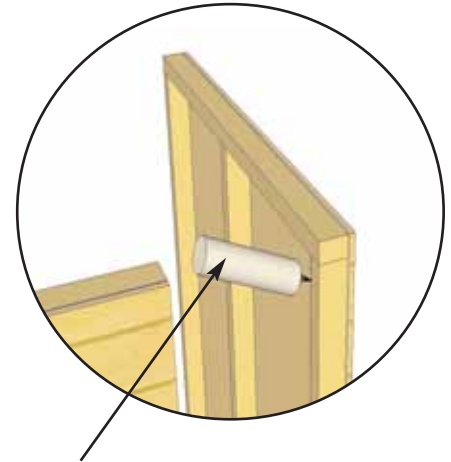
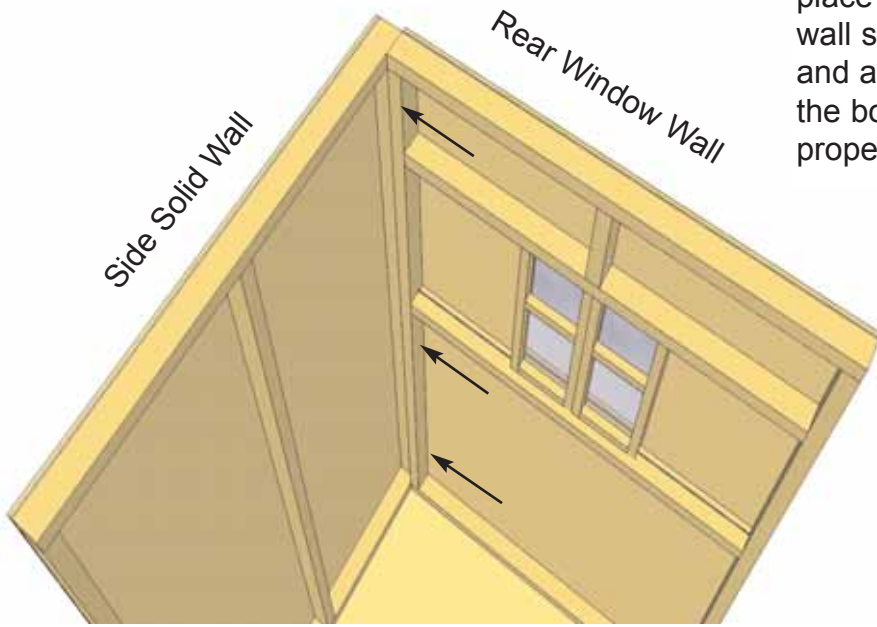

Optional - Caulking seams will help prevent moisture from entering at seam.
Caulking not included in kit.

18. With the corner wall attachment complete, position a Solid Rear Wall Panel so bottom 2x3 wall framing is sitting flush with outside floor joists and plywood floor. Wall siding should overhang floor by approximately 1/2"

When positioned correctly, add a second rear wall panel and attach both rear wall panel studs together as per **Step 17.**

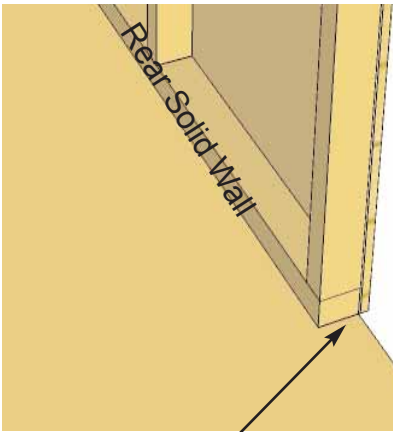

2x3 wall framing flush with outside of plywood.

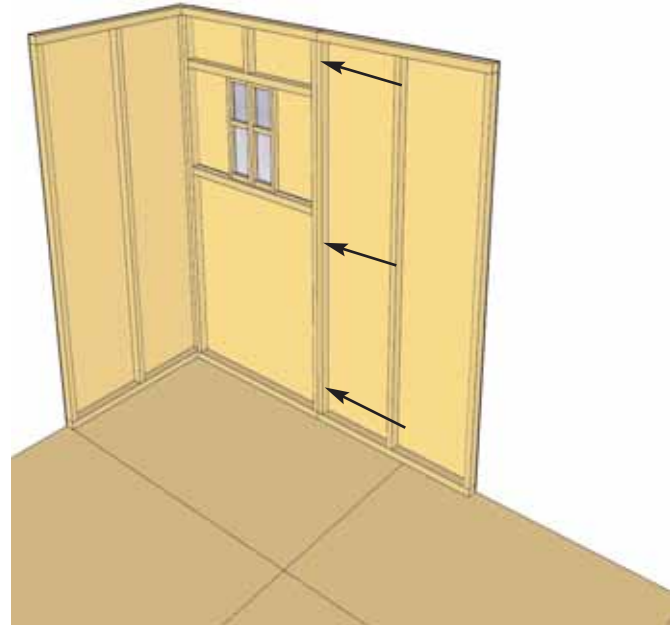

Do Not Attach Walls To Floor until Step 27.

19. Position the final Rear Panel on the floor. (Window Wall Panel).

Positioned vertical wall studs correctly together and attach as per **Step 17.**

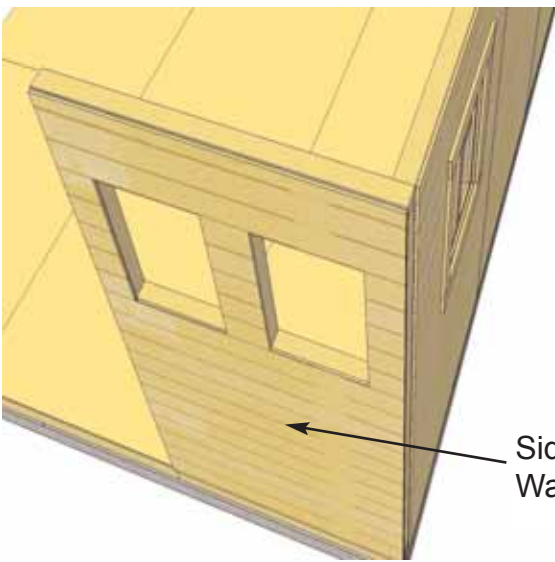

Be sure that rear wall panels fit between the side wall panels (sandwiched)

Side Window Wall Panel

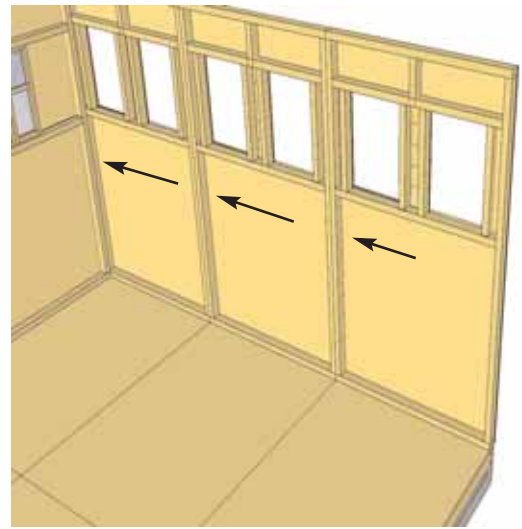

20. Attach a Side Window Wall Panel (2 windows in panel) in corner. Attach as per **Step 17**. Start positioning and securing remaining Side Window Wall Panels on your floor. Attach wall studs together as per **Step 17**.

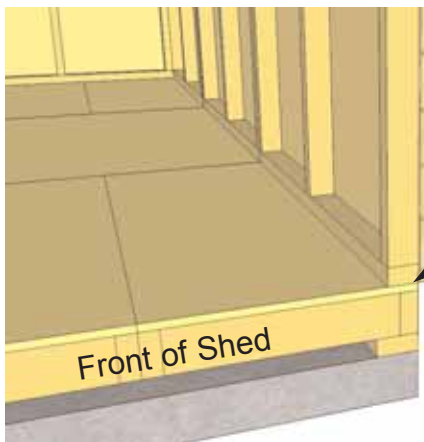

Wall panel will sit flush with floor framing at front of shed.

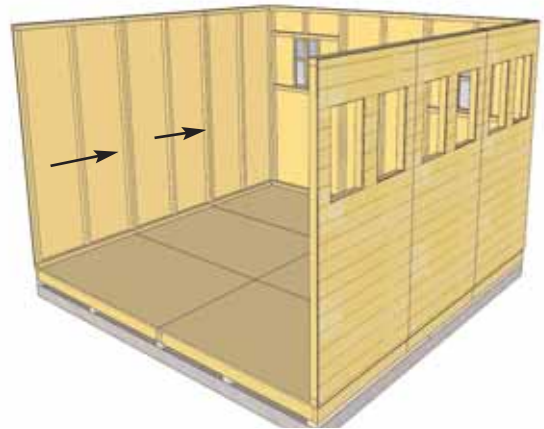

21. Complete all Side Wall attachments. At the front of the shed, side walls will sit flush with front of floor framing.

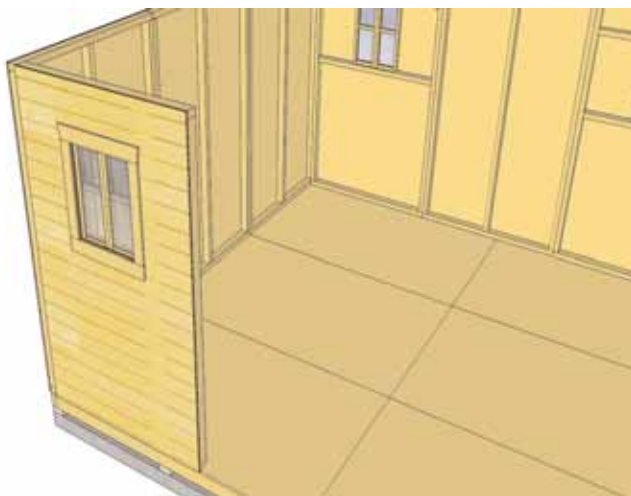

22. In the Front Corner, attach a Window Wall Panel. Line wall studs up as per **Step 17** and secure together.

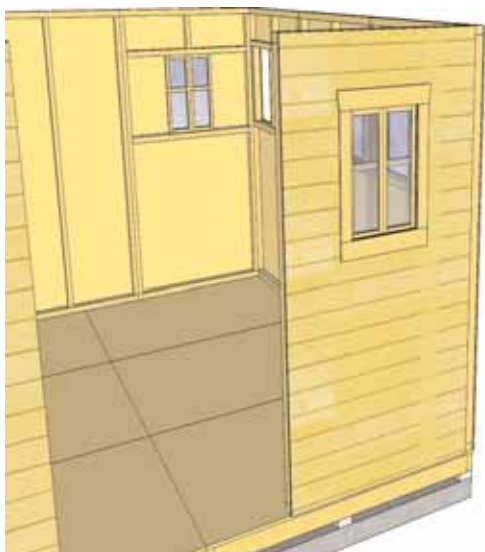

Narrow Wall Panel.
(can go on left or right side.)

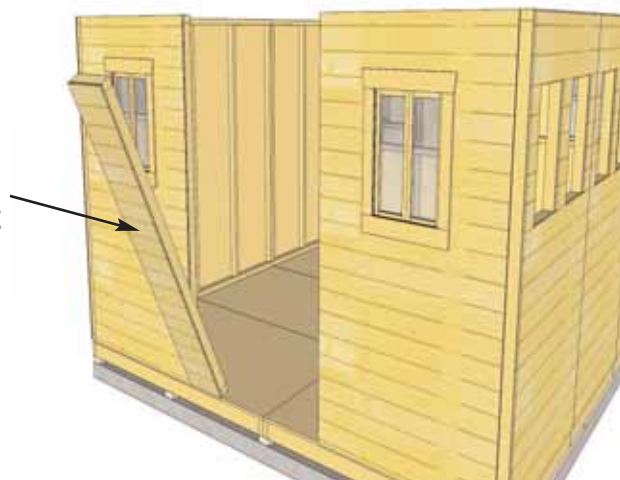

23. Secure 2nd Front Corner Window Wall Panel leaving a space in the middle for doorway. When Front Window Walls are attached in corners, lift and place Narrow Wall Panel up next to wall stud.

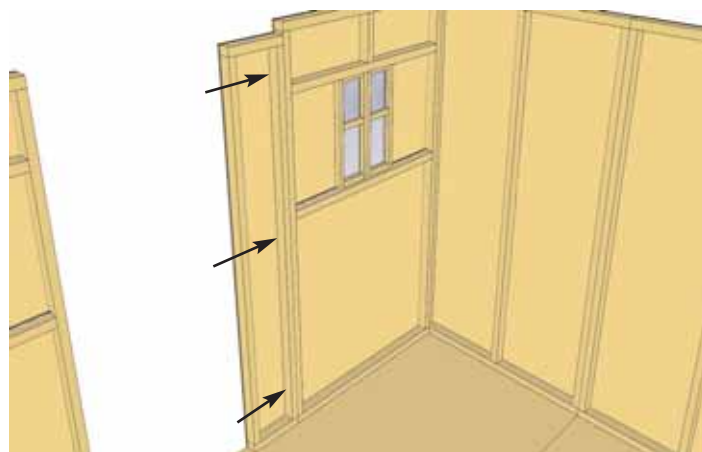

24. Line up side wall stud and Narrow Wall stud so framing is flush with each other on the outside. Attach Studs together with 3 - 2.5" screws as per **Step 17**. Note, Narrow Wall are 73" high (2" shorter than wide walls).

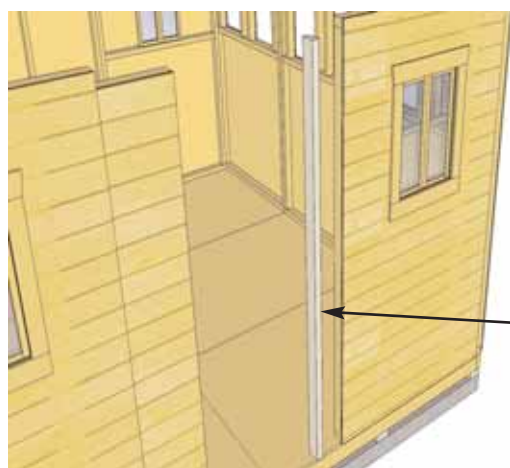

Vertical Door Jamb

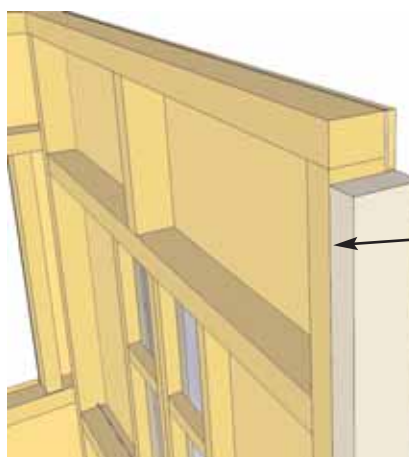

Jamb sits flush with Wall Framing

25. Locate Vertical Door Jamb and position flush against right wall panel stud. The Jamb is 3" wide and will sit flush to outside of wall siding. When positioned correctly, secure Jamb using 4 - 2.5" screws.

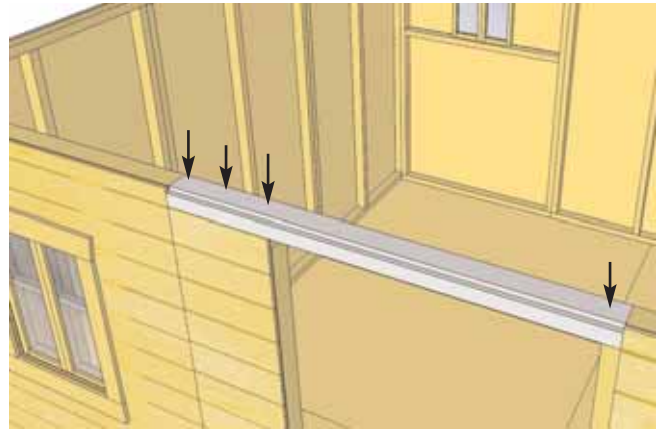
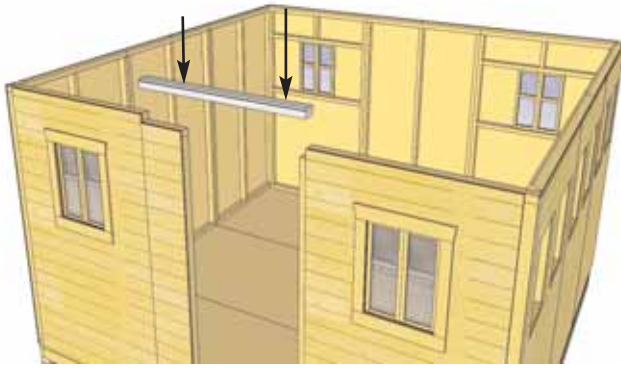

26. Position and attach the Door Header to Door Jamb and Narrow Wall Panel top framing. Header should sit flush with Door Jamb and Outside of Narrow Wall Panel Siding. Attach with 4 - 2.5" screws.

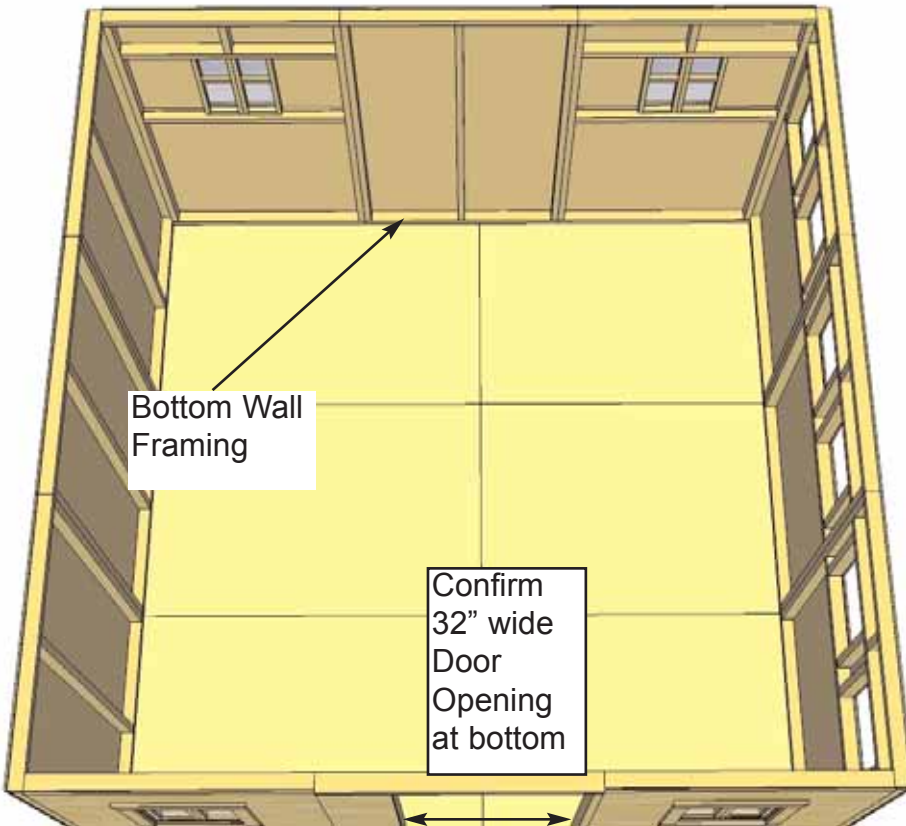

27. When all walls are attached together, check alignment with the floor. Bottom wall framing should sit flush with outside of floor joists and plywood floor. When positioned correctly, fasten bottom wall plates to floor using 4 - 2.5" screws per wall panel. **Confirm 32" wide door opening at bottom.**



Angle screws into perimeter Floor Joists.

Optional - Caulking seams will help prevent moisture from entering at seam. **Caulking not included in kit.**

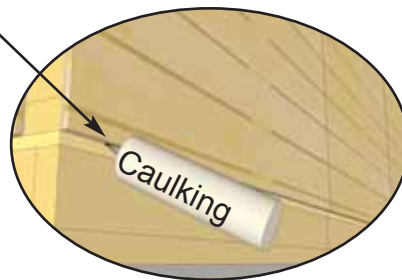

Important- If walls are not lining up and appear higher or lower to each other, please check the level of your floor. You may need to make slight adjustments before proceeding.

Top Plates



Top Plates should be flush with inside of wall framing.

Angle cut on 1 end.

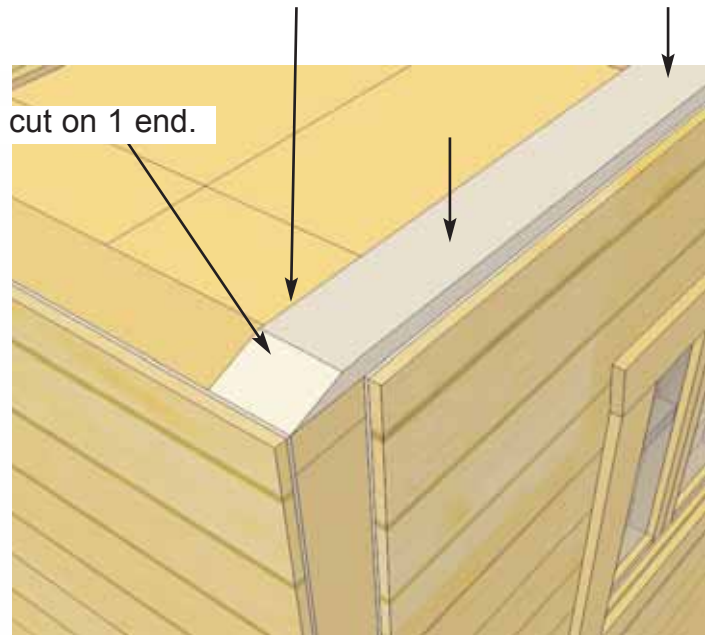

28. Position **Front Top Plates** on top of wall framing so it is flush on the inside with 2x3 wall frame. There are 2 pieces of Front Top Plates. Together, the plates should be centered evenly on the wall left to right. Attach by screwing down into top wall framing with 4 - 2" screws per Plate.

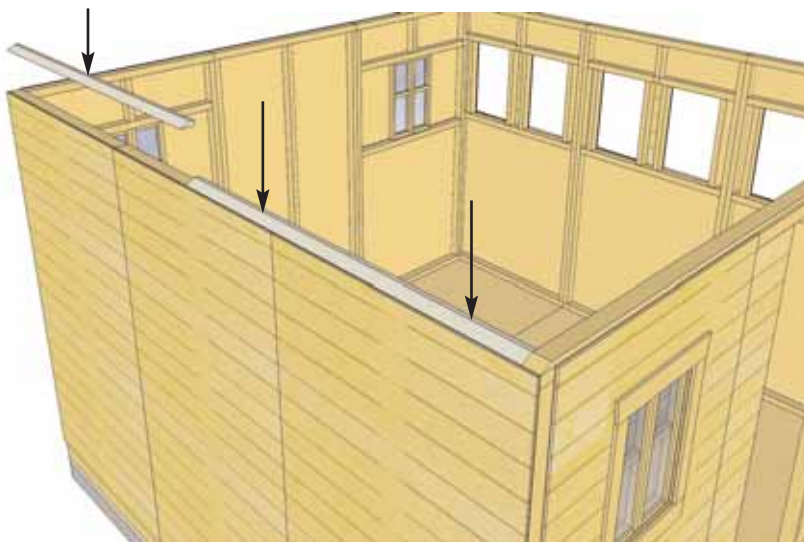

29. Next, attach the 2 Side Top Plates. The side top plates are angle cut down the length. Once again, position top plate on wall plate so it is flush with inside of wall plate. Side plate should also be flush with Front Top Plate. Secure with 4 - 2" screws per piece.

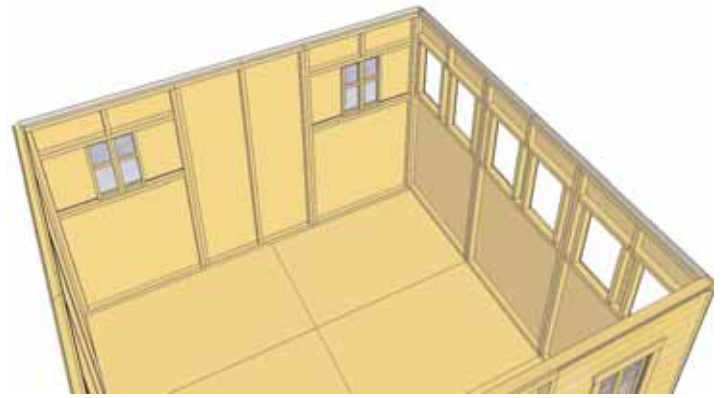
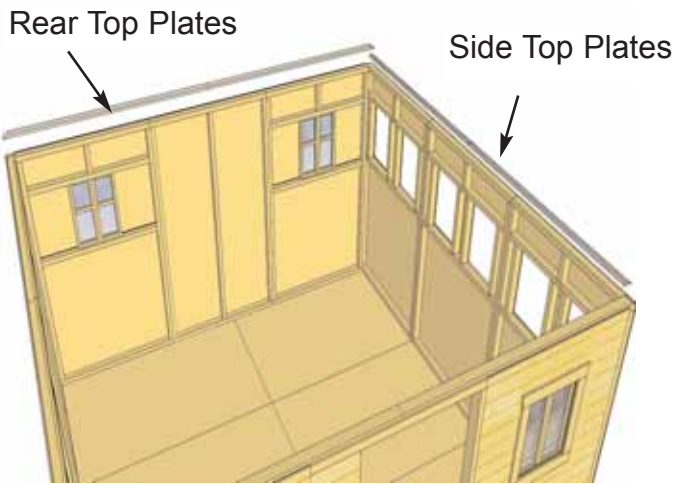

30. Position remaining Rear and Side Top Plates on rear wall top framing to complete. Use 4 - 2" screws per piece.

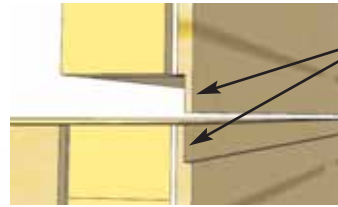

Lap Siding of panels will fit together.

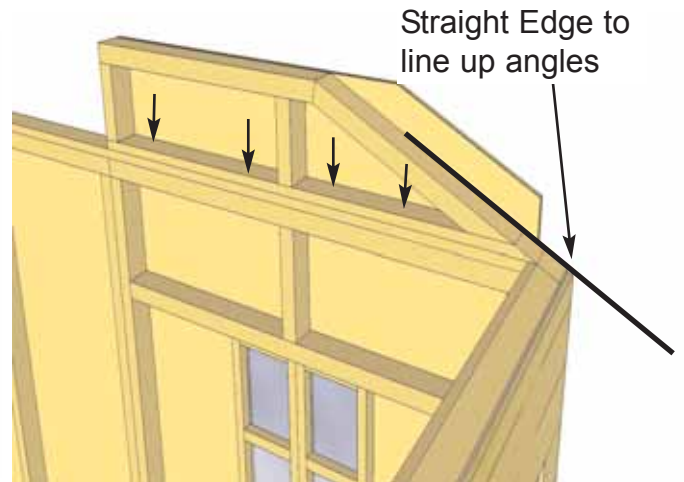
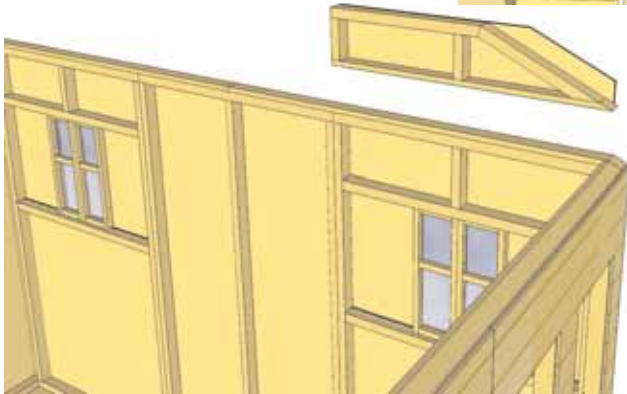

31. Locate and place an Angled Wall Extender on Rear Wall Top Plate. Position so Top Plate and Extender Wall angles line up and are flush with each other. When in place, secure with Use 4 - 2 1/2" screws per piece.

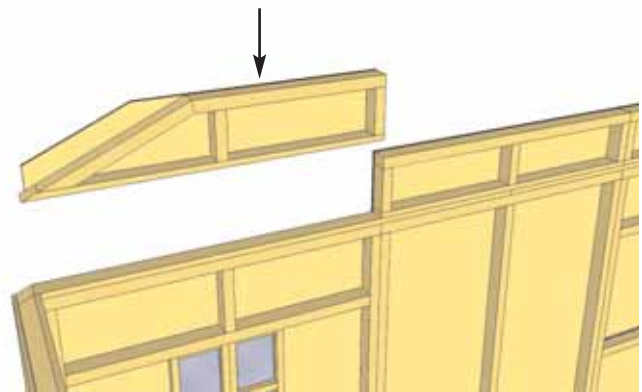
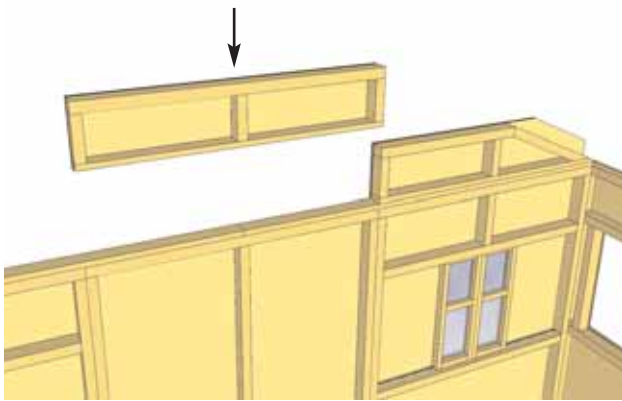

32. Locate and place the Middle Wall Extender on Top Plate and flush with Angled Extender Wall framing. When correctly in place, secure with 4 - 2 1/2" screws. Complete remaining Angled Wall Extender attachment following **Step 31**. Use 4 - 2 1/2" screws to connect Middle Wall to Angled Extender Walls. See **Step 33**.

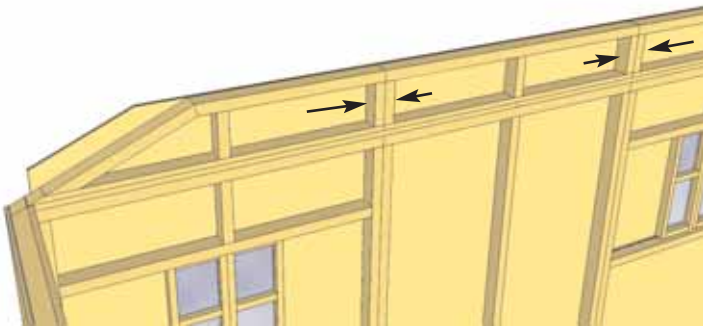

33. After completion of Rear Wall Extensors, complete the front wall Extensors following **Steps 31-32.**

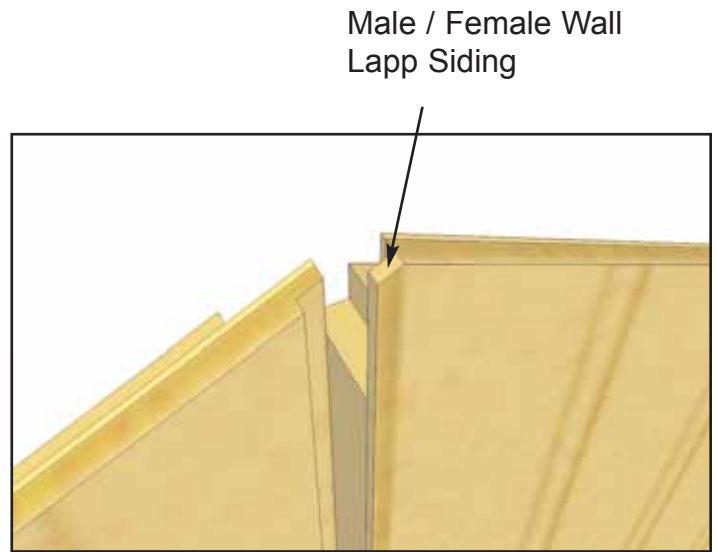
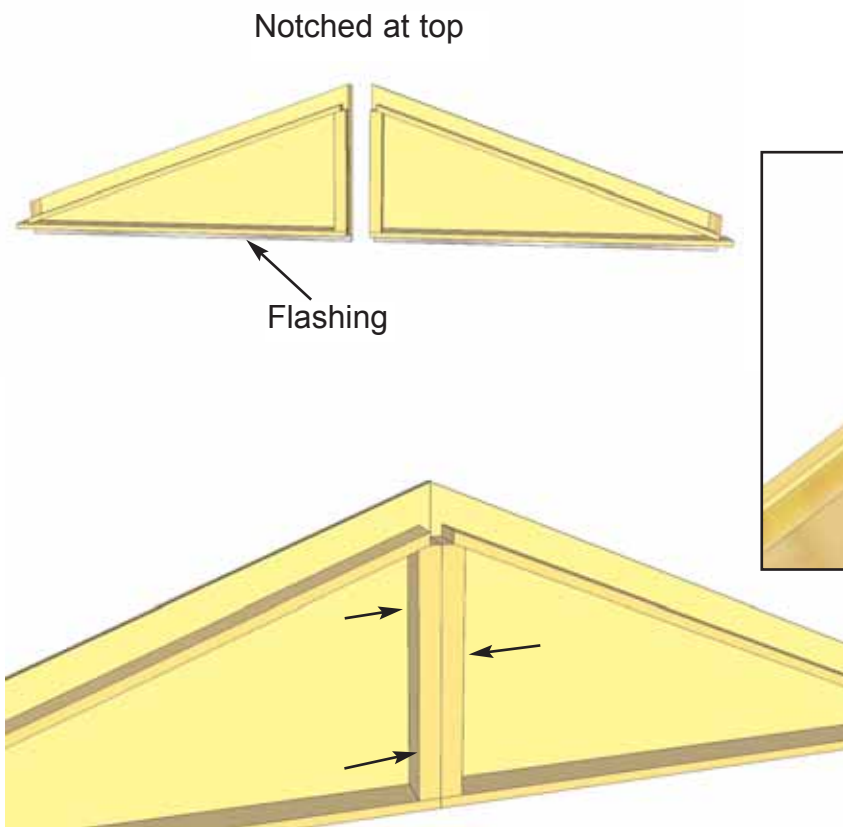

34. Locate Gable 1/2 Walls for both sides of the shed. Align framing and wall siding lapp together. Screw center wall framing of each piece together with 3 - 2 1/2" screws.

Note, prior to attaching, try each combination of Gables for best fit.

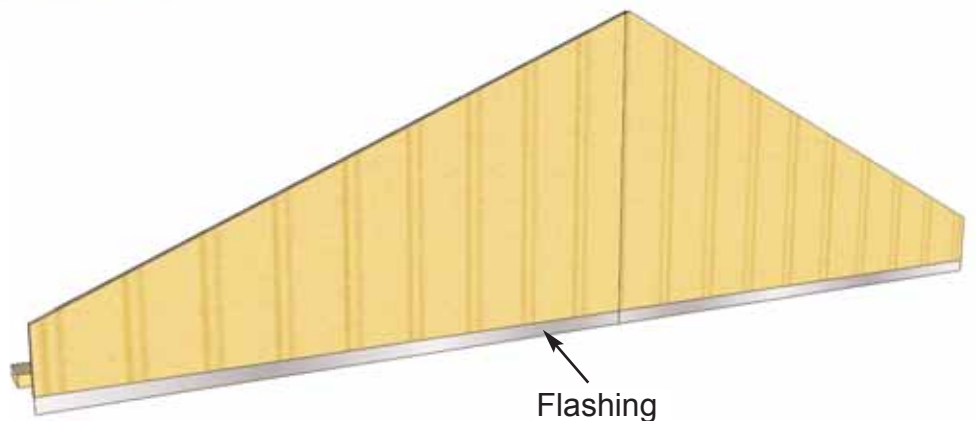

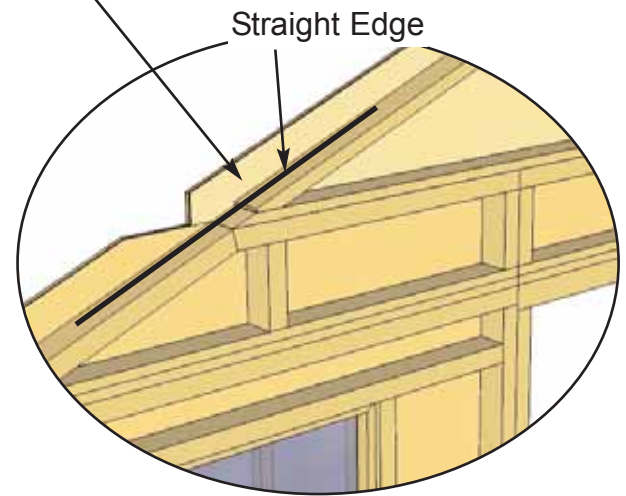
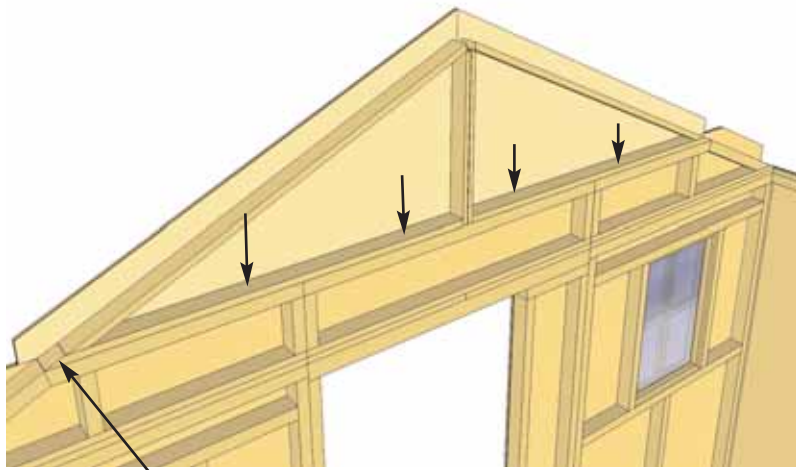

35. Lift completed Gable Section up and place on top of front Wall Extenders. Move Gable Section framing left or right to line up with Wall Extendor framing. Use a straight edge to check for correct alignment. When in place, tack down Gable framing for now with 4 - 2 1/2" screws.

Note, Gable alignment may need to be adjusted after Rafters are installed in **Step 46**. When complete secure Gable Section with 4 additional 2 1/2" screws.

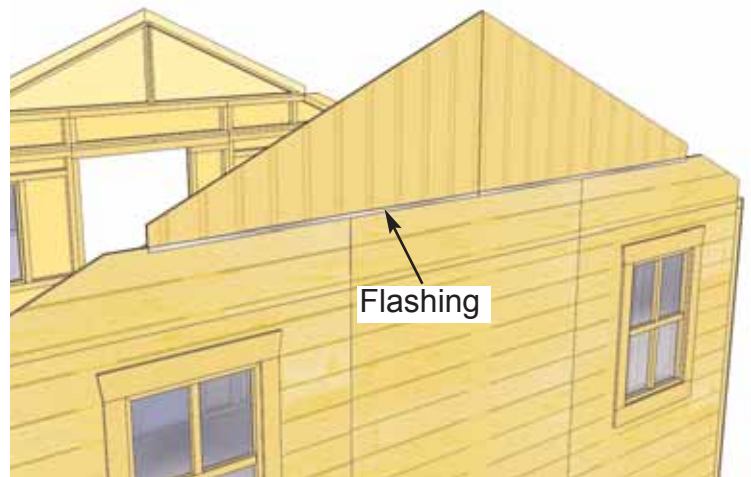
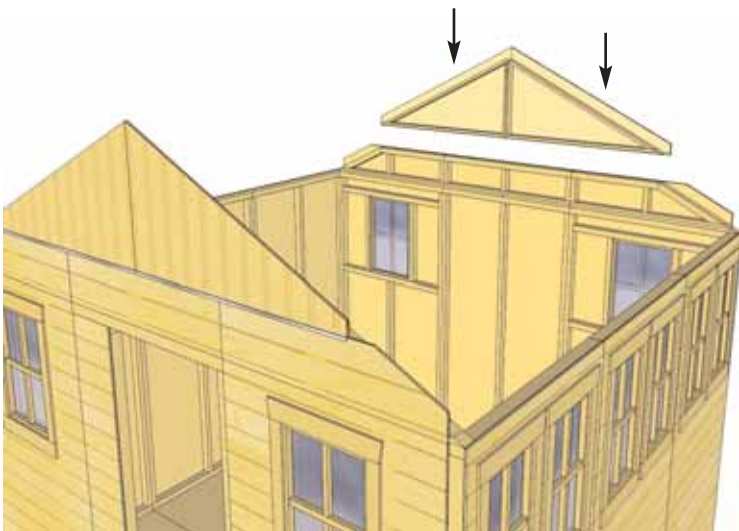

36. Lift, align and attach Rear Gable Section as per **Step 35**.

C. Rafter & Roof Section

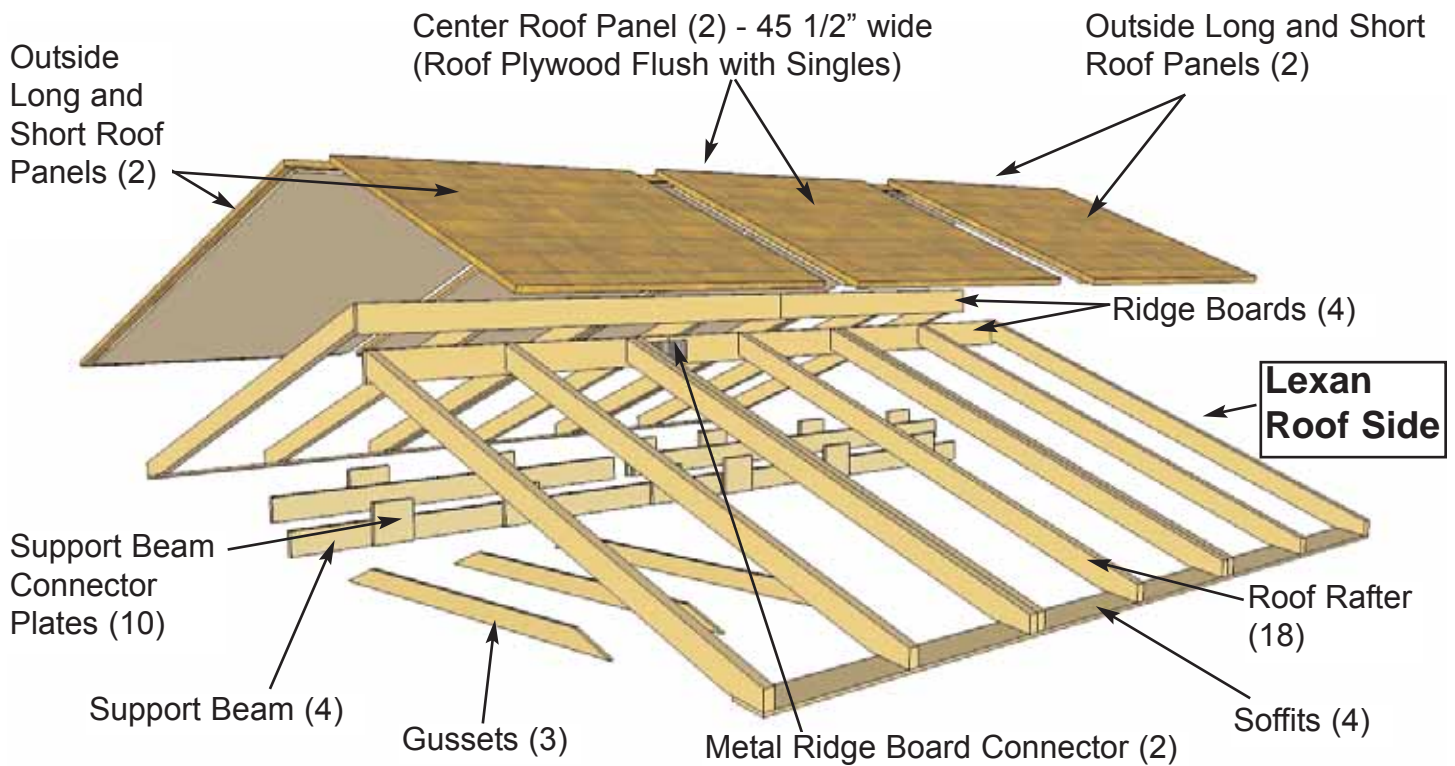

Rafter Section - Important:

Locate all parts necessary to assemble One Rafter Section:

Parts for One Rafter Section

- 9 - 81 1/8" long 1 1/2" x 3 1/2" Rafters
- 1 - 3/4" x 4 1/2" x 52 1/2" - Ridge Board
- 1 - 3/4" x 4 1/2" x 84" - Ridge Board
- 1 - 1/16" x 3" x 7" - Metal Ridge Board Con.
- 2 - 1/2" x 4 1/2" x 68 1/4" - Soffits
- * Must complete 2 Rafter Sections

Remaining Rafter Pieces:

- 2 - 3/4" x 3 1/2" x 56 1/2" - Support Beam Pieces
- 2 - 3/4" x 3 1/2" x 75" - Support Beam Pieces
- 10 - 5/8" x 6" x 6" - Support Beam Conn. Plates
- 3 - 3/4" x 3 1/2" x 72" - Gussets

Follow **Steps 37-40** to Assemble Rafter Sections. Make sure to complete on a flat level surface.

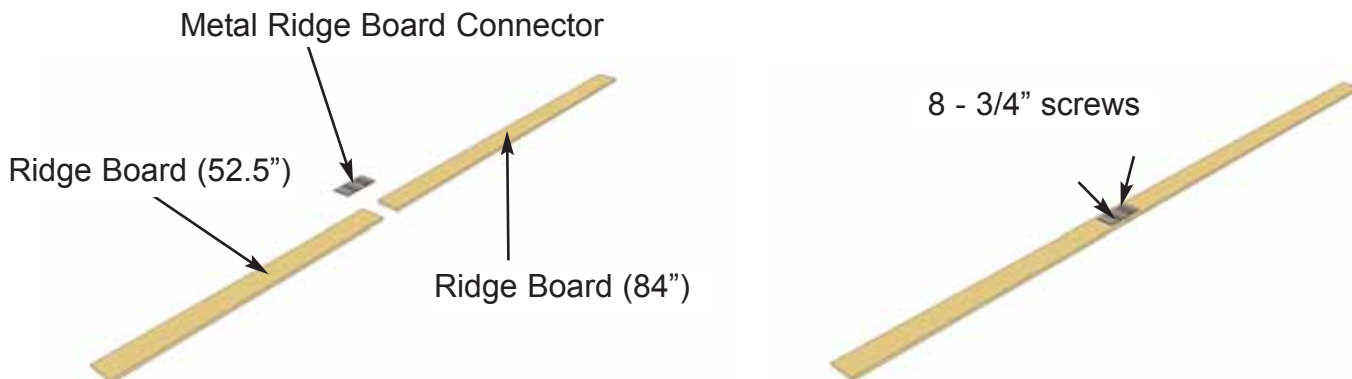

37. Locate 3/4" x 4 5/8" x 84" & 52 1/2" **Ridge Boards** and attach together with **Metal Ridge Board Connector** using 8 - 3/4" screws evenly on boards. Total Length when connected is 136 1/2". Complete two Ridge Boards.

38. With 9 Rafters, 2 Soffits and completed Ridge Board, lay out on level ground as shown to the right. Double up Rafters as illustrated. Screw doubled up Rafters together with 3 - 2 1/2" screws per piece.

Note: completed rafter section will be flipped over in **Step 41**.

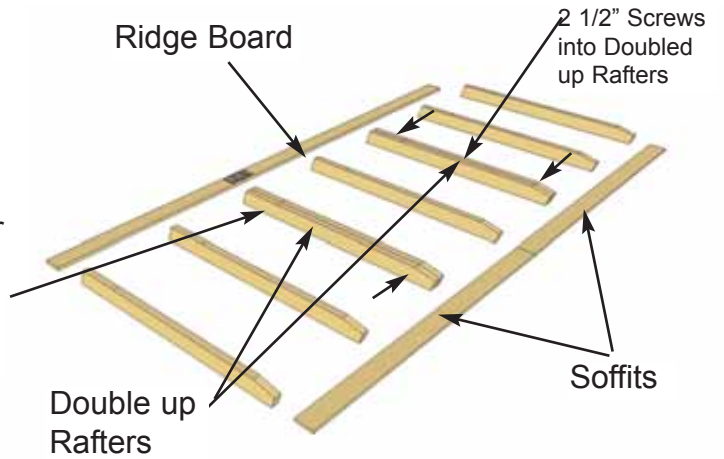

4 1/2" wide Ridge Board

2 1/2" Screws into Doubled up Rafters

39. Attach completed Ridge Board to ends of both outside rafters with 2 - 2" screws per end. Measure and position interior Rafters as illustrated below. When positioned correctly, attach Ridge Board to remaining rafters with 2 - 2" screws /rafter end.

Important: Measure 20 1/2" spacing accurately to accommodate Lexan Panels. See **Step 67**.

Important: Pilot Hole Ridge Board to prevent splitting!

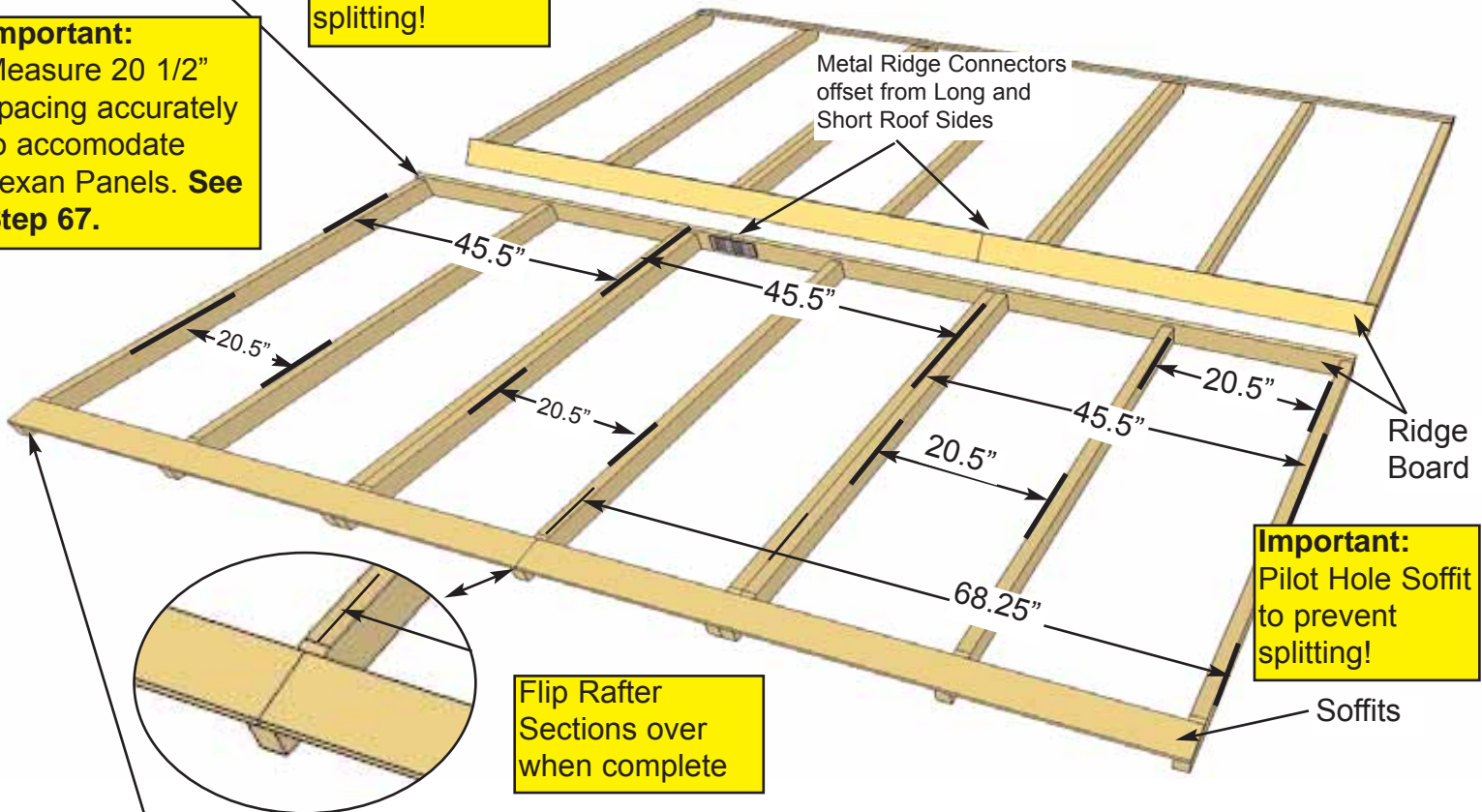

Important: Pilot Hole Soffit to prevent splitting!

Flip Rafter Sections over when complete

40. Attach end of a 68 1/4" long Soffit Board flush to ends of outside rafters with 2 - 1 1/4" screws per rafter end. Drill pilot hole in Soffit ends to prevent splitting. Complete both outside Rafter / Soffit connections first. Measure and position interior Rafters as illustrated above. When positioned correctly, attach Soffits to remaining rafters with 2 - 1 1/4" screws /rafter. **Important - Pilot Hole Soffits to prevent splitting.** Flip completed rafter section over. Complete remaining Rafter Section as per **Steps 38 - 40** with the following exception.

When attaching Ridge Board to Rafter ends, make sure Metal Ridge Board Connector is positioned so offset to first Rafter Section. See **Step 45 for illustration.**

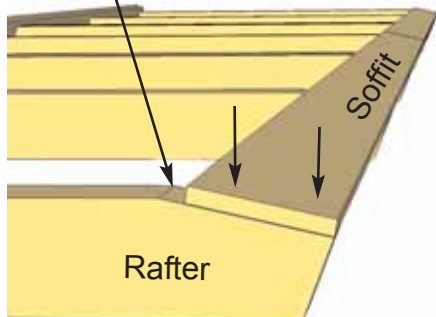

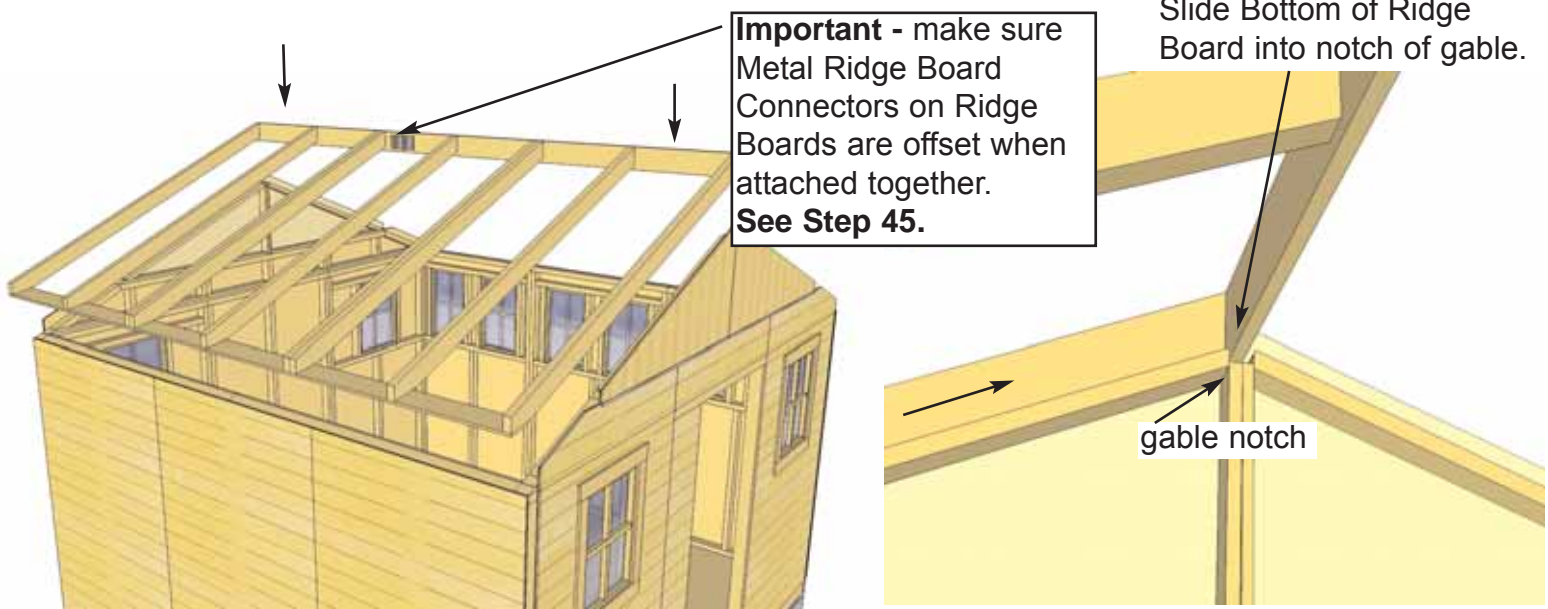

41. Starting with the Long Cedar Shingle Roof Side, lift and flip completed Rafter Section over so Soffit is facing down. Slide rafter up on gable framing until bottom of Ridge Board slips into gable notch. Position rafters so they sit evenly on Gable framing from side to side.



42. Where Wall and Soffit meet, a small gap may appear. Confirm all Rafters are resting on Top Plate.

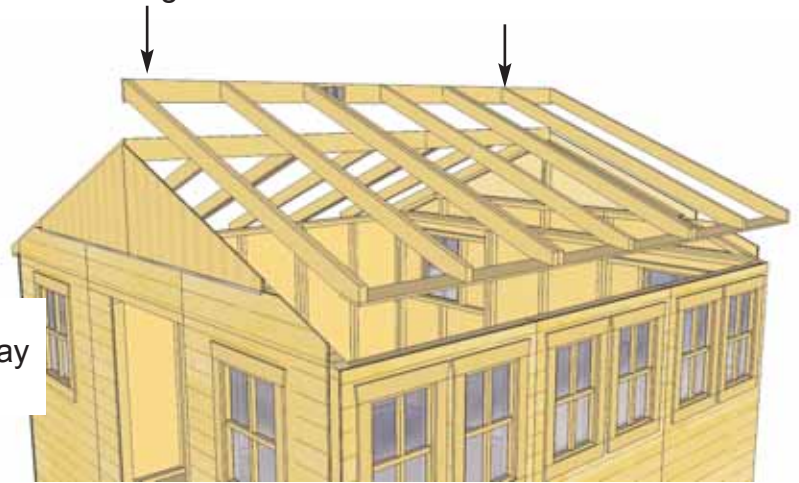

43. Lift and flip 2nd Rafter Section up and place on Gable framing. **Make sure Metal Ridge Board Connectors of both Roof Sections are offset. See Step 45.**

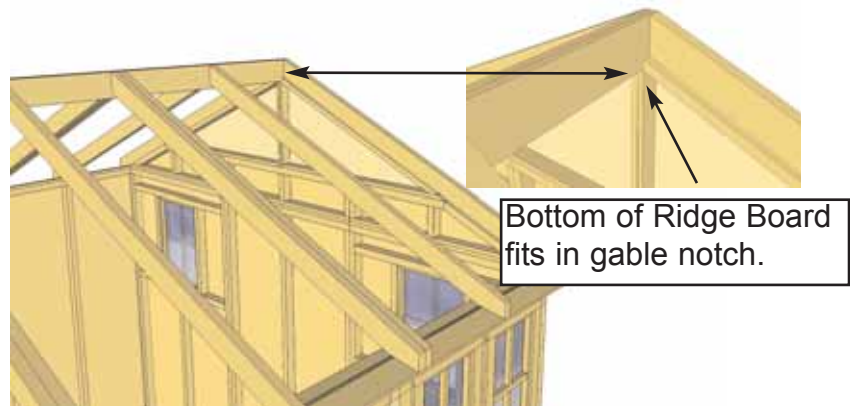
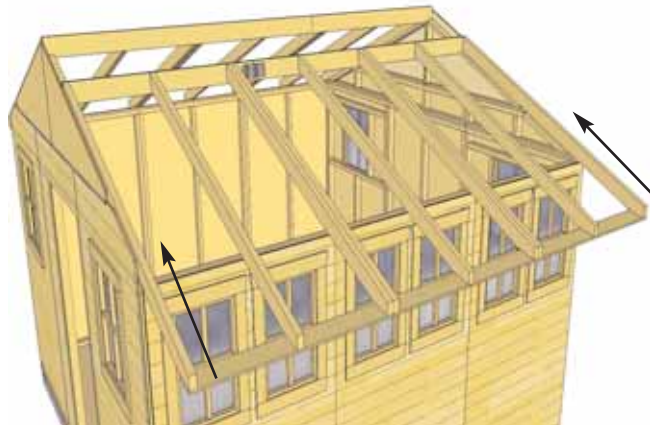

44. Slide Rafter Section up on Gable framing so bottom of ridge board slips into Gable notch. Soffit will sit approximately 1/8" away from wall as per **Step 42.**

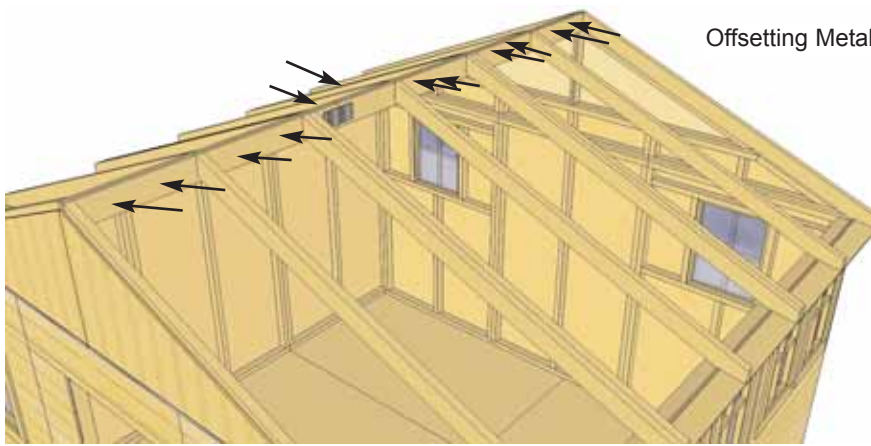

Offsetting Metal Ridge Board Con.

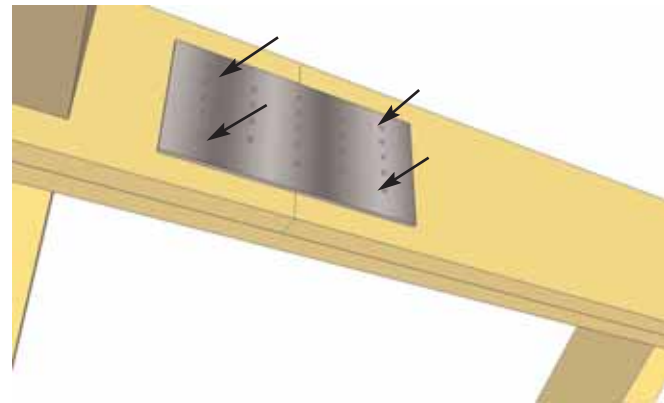
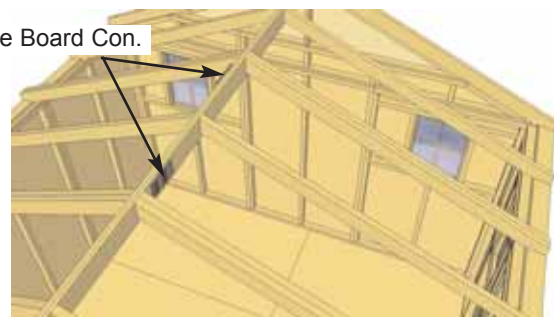

45. Where Ridge Boards meet, align together so they are flush with each other and secure them with 12-1 1/4" screws. To completely secure Ridge Boards, place 4 - 1 1/4" screws into any of the remaining Metal Ridge Board Connector holes. Complete both sides.

Important - if there is a gap between Ridge Boards, try pushing side walls closer together from outside. Walls should be 136 1/2" apart at top from inside of wall plate to wall plate.

Important: - If Gable framing does not line up with Rafters, remove temporary 2" screws from gable framing. Re-align gable and secure with 6 - 2" screws total.

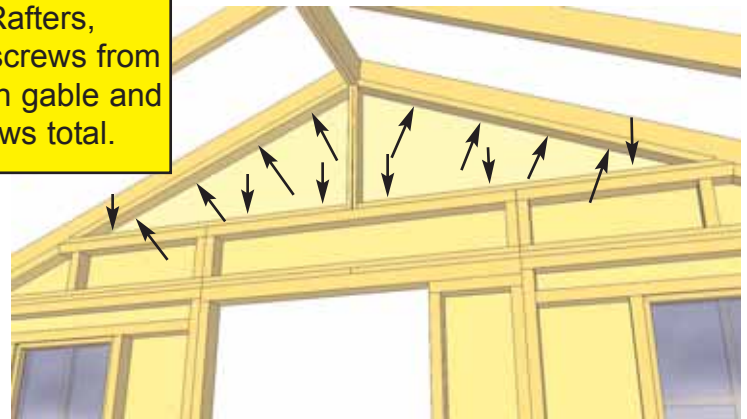
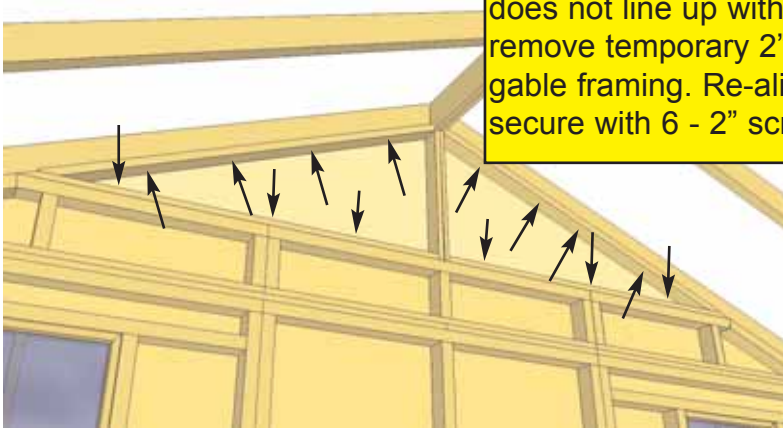

46. With both Rafters Sections correctly aligned, secure Gable framing to both outside rafters with 8 - 2" screws per side at top and with 6 additional 2" screws into wall top plates at bottom.

3/4" x 3 1/2" x 56 1/2" & 75" long - 2 pcs.

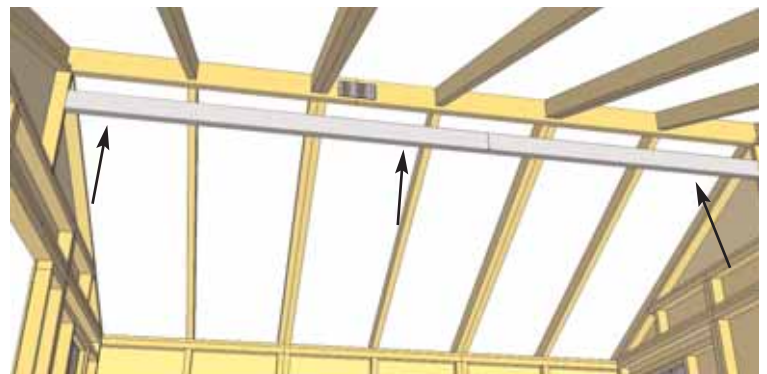
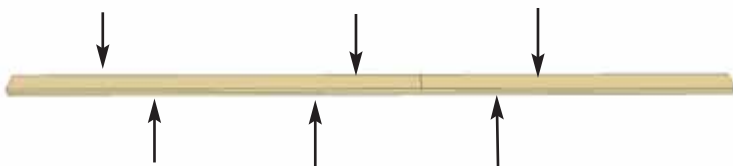

47. To increase the strength of rafters, assemble Rafter Support Beam. There are 2 pieces per side - 4 in total (56 1/2" and 75" long). Position a long and short piece so the total length is 131 1/2". Position 2nd pair of Supports on top of first staggering the joint. Screw together with 6 - 1 1/4" screws. Lift Rafter Support Beam and place directly under Roof Ridge Board.

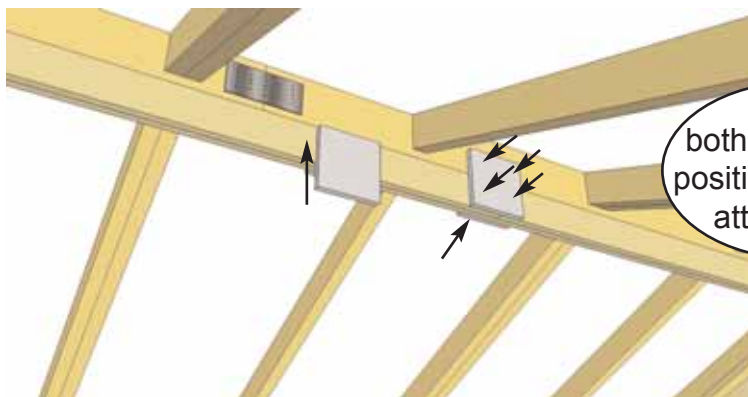

Align both Plates in position prior to attaching.



48. Attach Support Beam to Ridge Board with 10 - Plywood Support Beam Connector Plates using 4 - 2 1/2" screws per Plate. Complete 5 pairs spacing evenly on Ridge Board. Prior to attaching **Gussets**, make sure walls are aligned correctly. Have two helpers push on both side walls at the top of wall from the outside until wall side plates are **136 1/2"** apart from the **inside** of wall plates.



Leave 1" gap to top of rafter

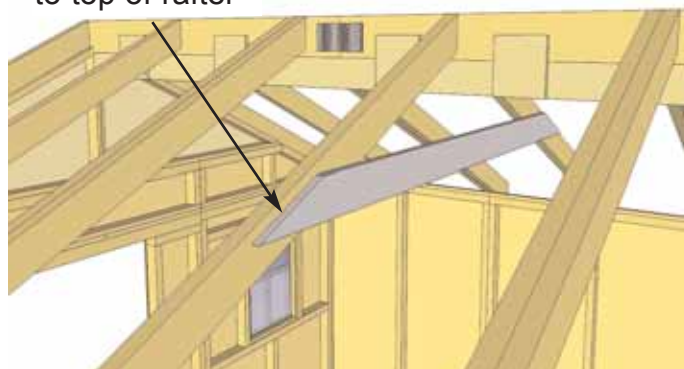

49. With walls correctly positioned, attach Gusset to Rafter with 4 - 2" screws per side. Use a level to check for square. Pilot hole end of Gusset to prevent splitting.

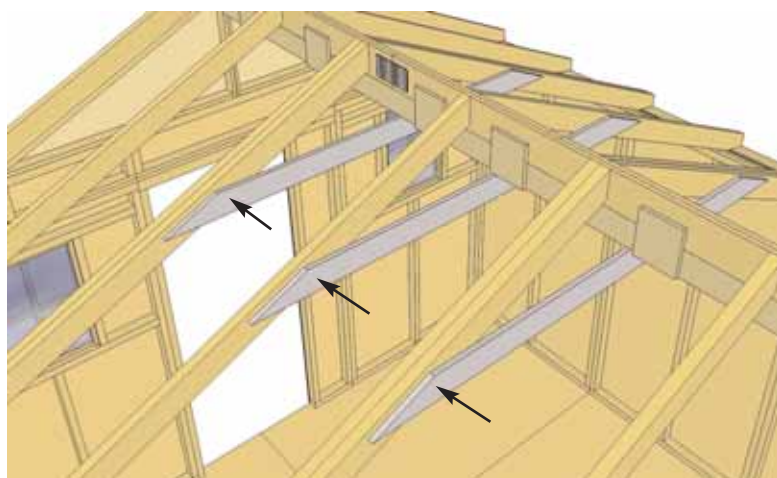

50. Complete all Gusset attachments as per **Step 49**.

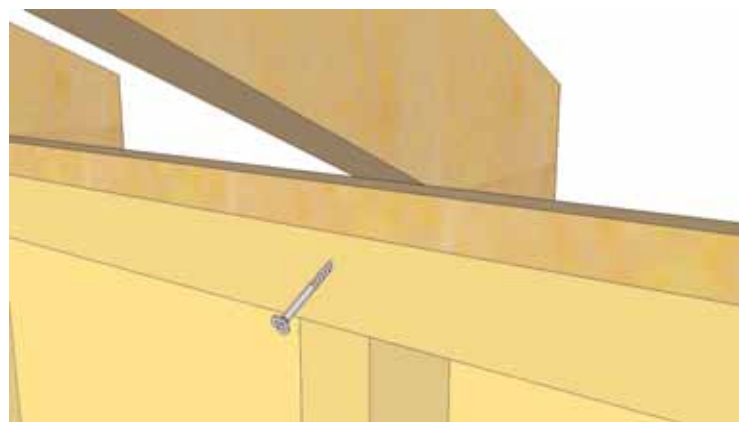

51. Secure Short and Long Rafters to Wall Framing with one 3" screw per rafter. Screw through Wall Frame at an angle.

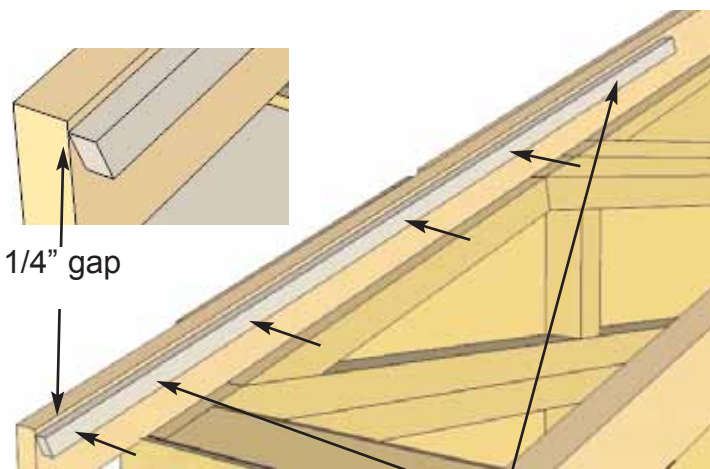

Further secure Cleats with 2 - 1 1/4" screws.
Important - Drill pilot holes to prevent splitting!

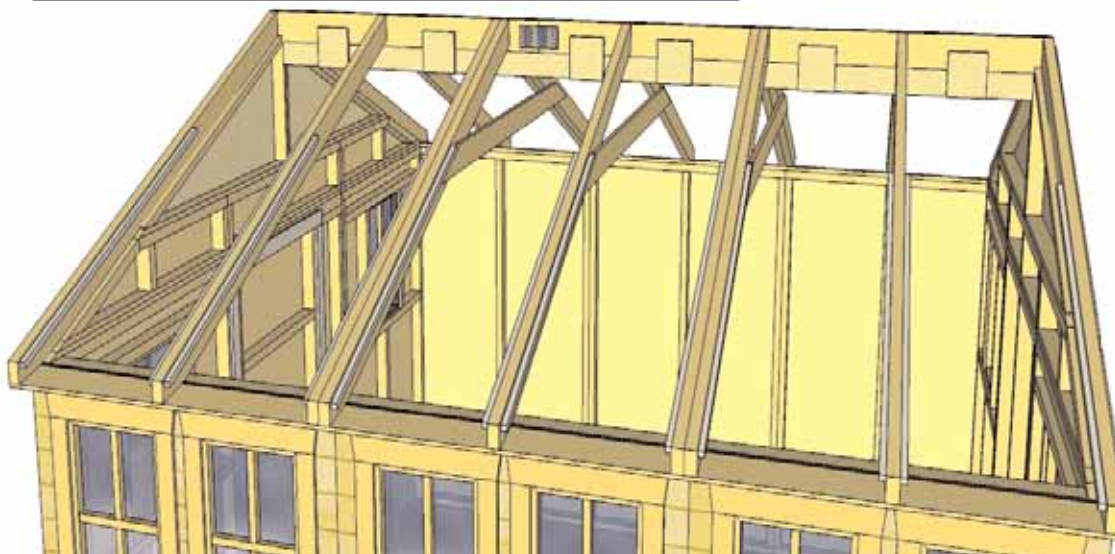

52. Position 3/4" x 3/4" x 48" long **Lexan Support Cleats** on each Long Rafter flush to end and recessed 1/4" down from top of rafter. Nail to rafter using 6 - finishing nails. **Note:** Start nails in Supports on ground first. Complete remaining 11 Lexan Support Cleats.

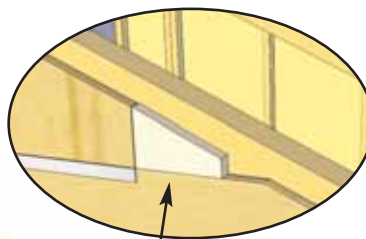
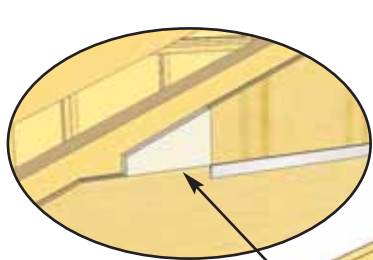

53. Position **Triangular Gable Trims (4)** in each corner of exposed cavity of Gable Wall and Roof Rafter. Use 2 finishing nails to secure into rafter.

Roof Section

Plywood flush with shingles

Shingles overhang plywood to outside



Long Cedar Shingle Roof Panel



Roof Plywood flush with rafter end.

54. Identify all **Roof Panels**. There are 2 Outside Right, 2 Center and 2 Outside Left Roof Panels. The outside of the panels will have shingles overhanging the plywood. Starting with an Outside Long Cedar Shingle Roof Panel, lift up and place on rafters so Plywood is flush with end of Rafter.

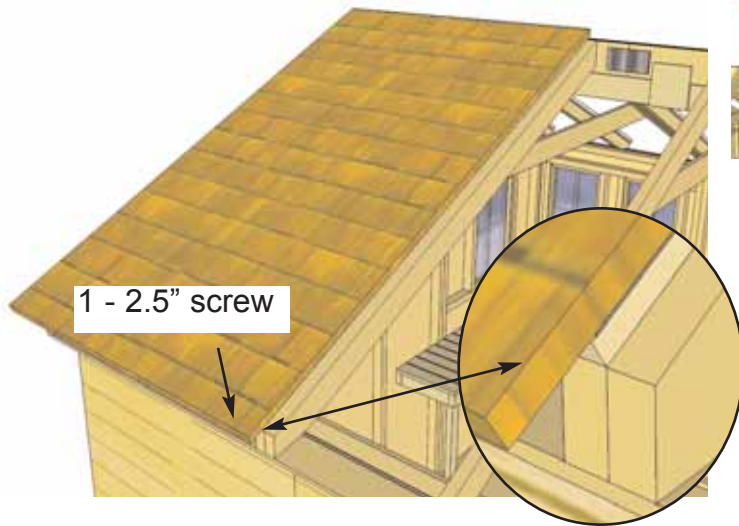

1 - 2.5" screw

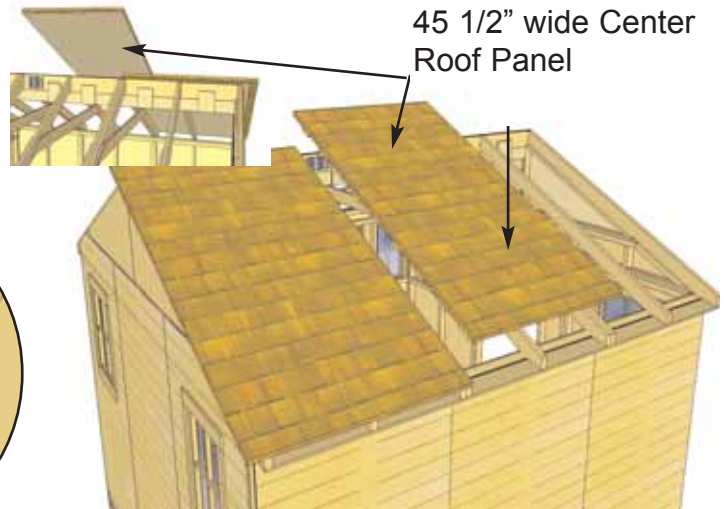

45 1/2" wide Center Roof Panel

55. Position Panel so roof plywood sits evenly on 2nd Rafter. Screw Panel to Rafters through bottom row of shingles with 1 - 2.5" screw. Lift up and place a Long Cedar Shingle Center Roof Panel on Rafters. Center Panel will have plywood flush with shingles on both sides. Position evenly on Rafters.



Roof Panel sitting equally on Rafters

56. Position Center Roof Panel with plywood flush with bottom end of rafter as per **Step 54**. From side to side, make sure Roof Panel is sitting equally on rafter. When positioned correctly, screw down with 2 - 2.5" screws only into outside lower shingles.

Shingles overhang
plywood on outside



57. Lift up and place remaining Long Cedar Shingle Outside Roof Panel on rafters. Plywood on roof should be flush with end of rafter at bottom.

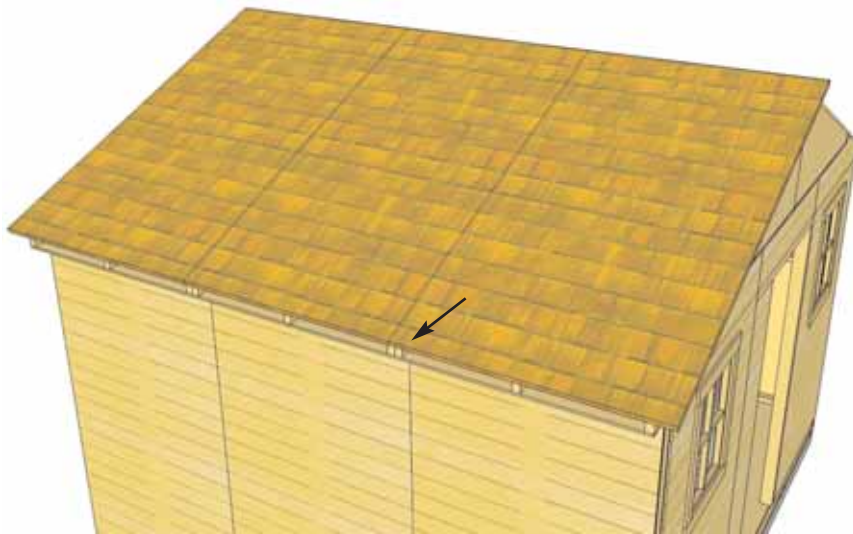

Lexan Side Roof Panel



58. With Outside Roof Panels centered on rafter and aligned as per **Step 54-55**. Screw down with 1 - 2.5" screw. Lift and Place Outside Panel for Lexan Side Roof.

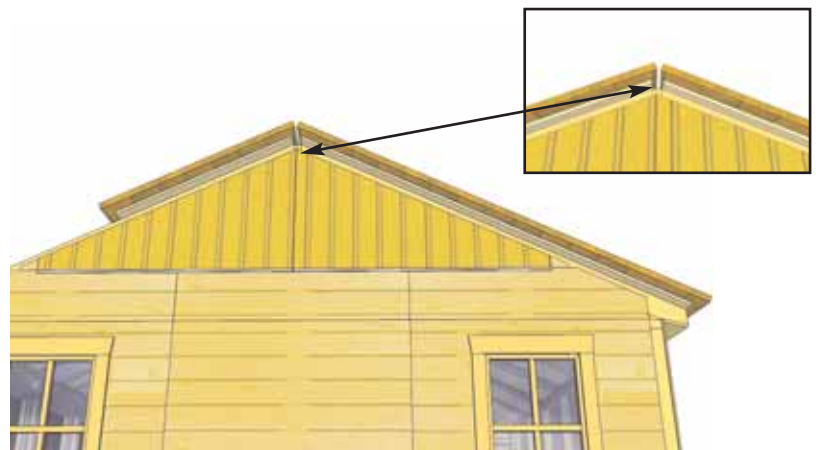
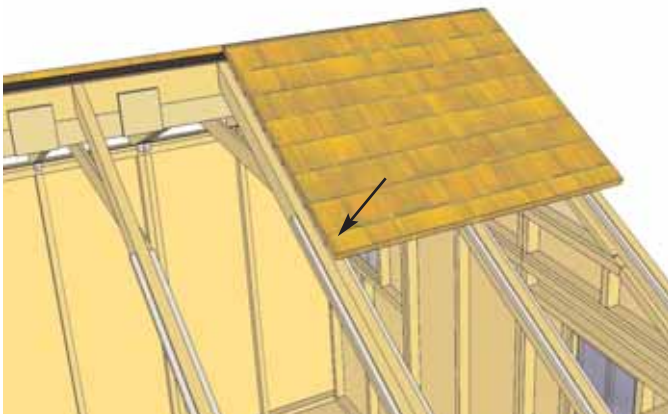

59. Position Outside Roof Panel equally on rafters as per **Step 55**. Align Roof Panel at top evenly at peak. Reach through opening in Rafters to attach. When positioned correctly, screw down with 1 - 2.5" screw in bottom row of shingles as illustrated above.

Hint: work from inside of shed to position and secure Lexan Side Roof Panels.

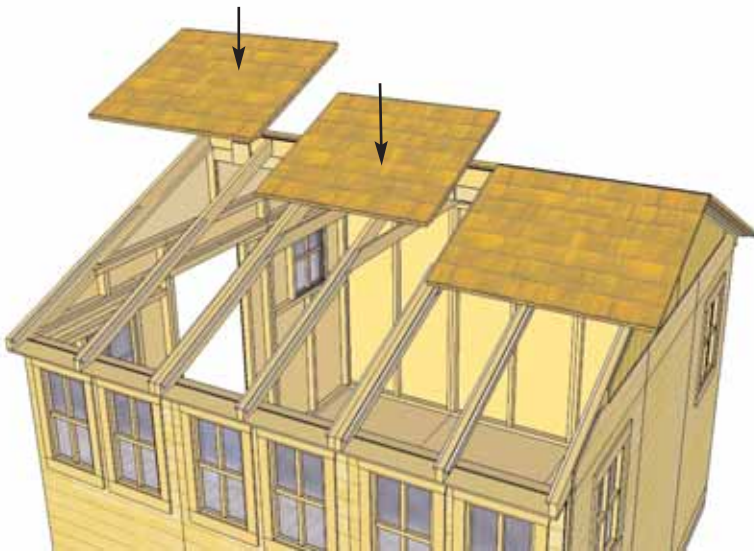

60. Follow **Steps 55 - 58** for positioning and attaching Lexan Side Roof Panels. Align evenly at roof peak.

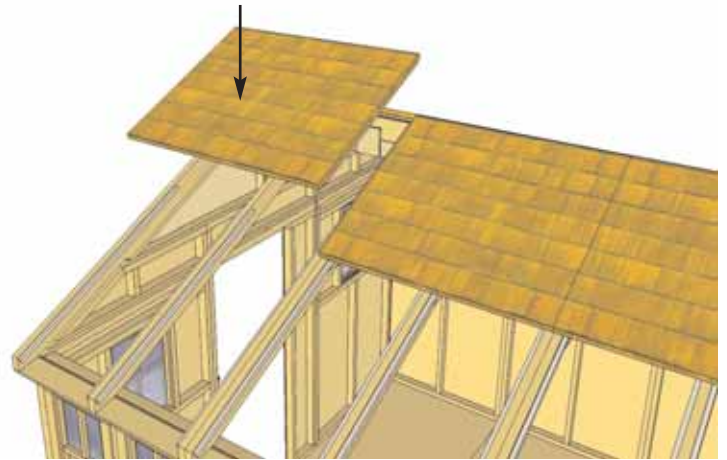
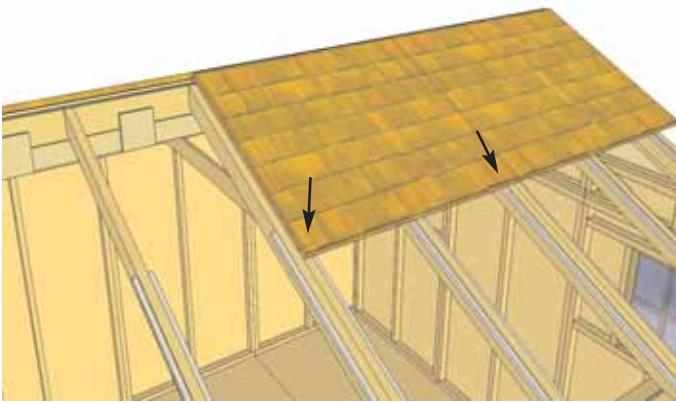

61. Work from inside the Sunshed when completing Lexan Side Roof Panels. Attach Center Panel with 2 - 2.5" screws as per **Steps 56**. Place remaining Outside Roof Panel into position.

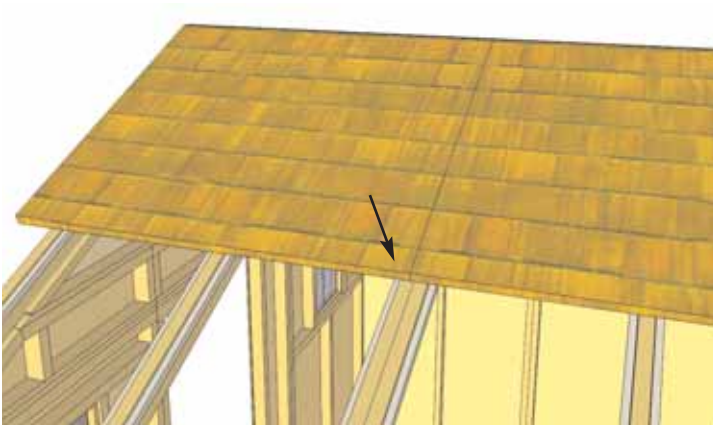

Completed Lexan Side Roof Panels



62. Position and attach Outside Panel as per **Steps 57-58**.



63. Next, time to install **Filler Shingles** to hide roof seams of shed. Starting at bottom on Short Roof Side, push a Long Filler Shingle underneath shingles directly above it until end is flush with bottom shingles.

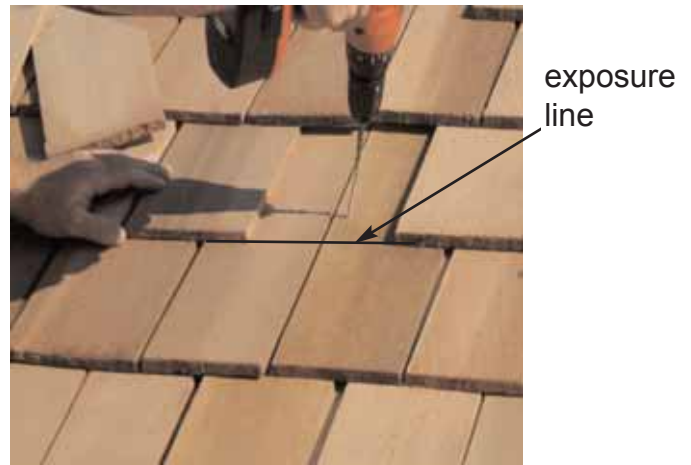

64. Screw first filler shingle down to rafters using 1 - 2 1/2" screw per panel (2 in total). Make sure to screw into both rafters.



65. Slide in the next Long Filler shingle and attach as per **Step 64**. At the top, use smaller shingles to fit. Attach final shingle to roof with 2 nails per shingle. Complete Long Shingle Roof Side next. There are 2 Long shingles and 1 Short shingle per roof seam.

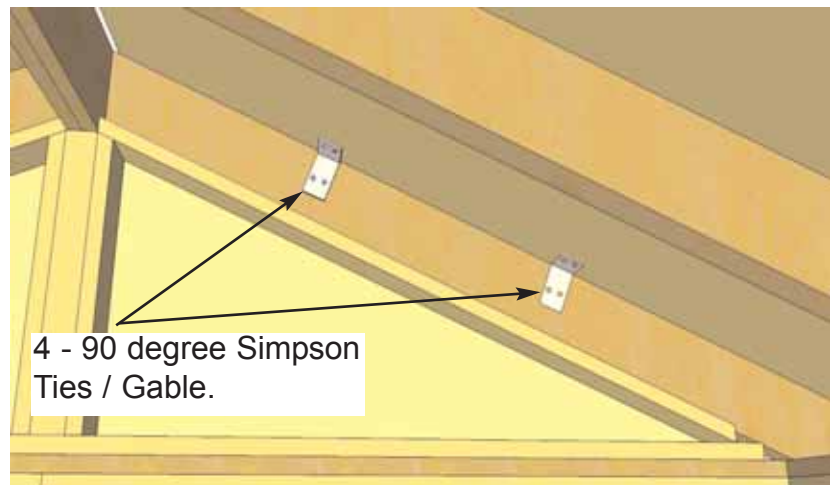

66. Position 2 Simpson Strong ties on plywood and outside rafters and secure with 4 - 1 1/4" screws. 4 ties per gable (8 ties in total).

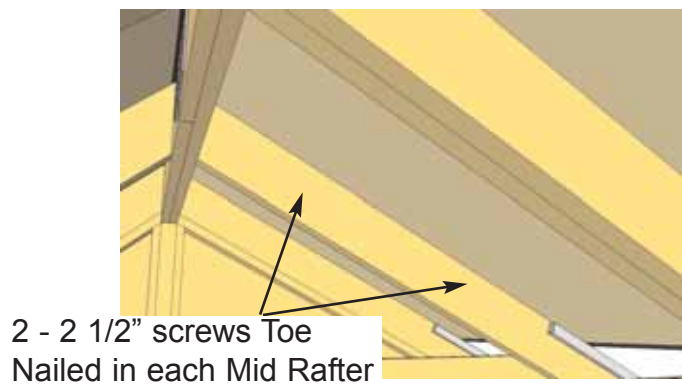
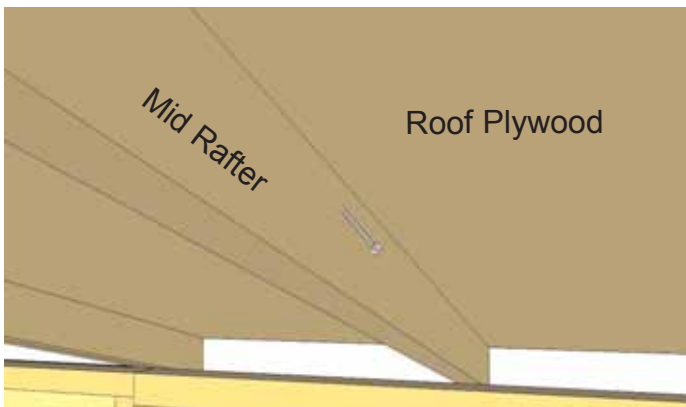

67. To further secure roof panels, from the inside, drill pilot holes in each Mid Rafter (3 per Rafter on Long Shingle Roof Side and 2 on Short Shingle Roof Side) on an angle. Using 2 1/2" screws, secure rafters to roof plywood. **Note:** from outside, push roof panel down so plywood sits flush against rafter when securing.

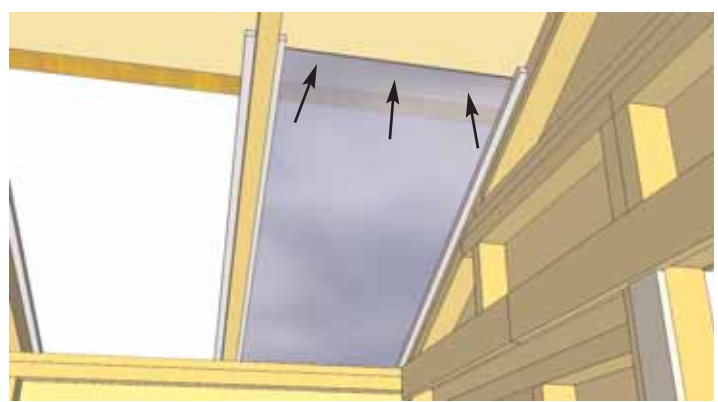
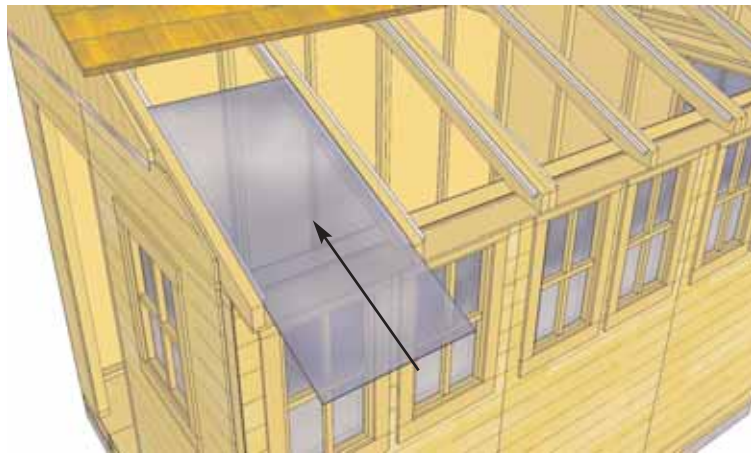

68. Installation of 6 **Lexan Panels** is next. Start by removing protective plastic layer on each panel. Slide panel up between rafters so it rests on Lexan Support Cleats. From the inside, carefully slide end of panel underneath shingles. After completion of **Step 69**, use 3 - finishing nails to secure Lexan Panel to underside of roof plywood.

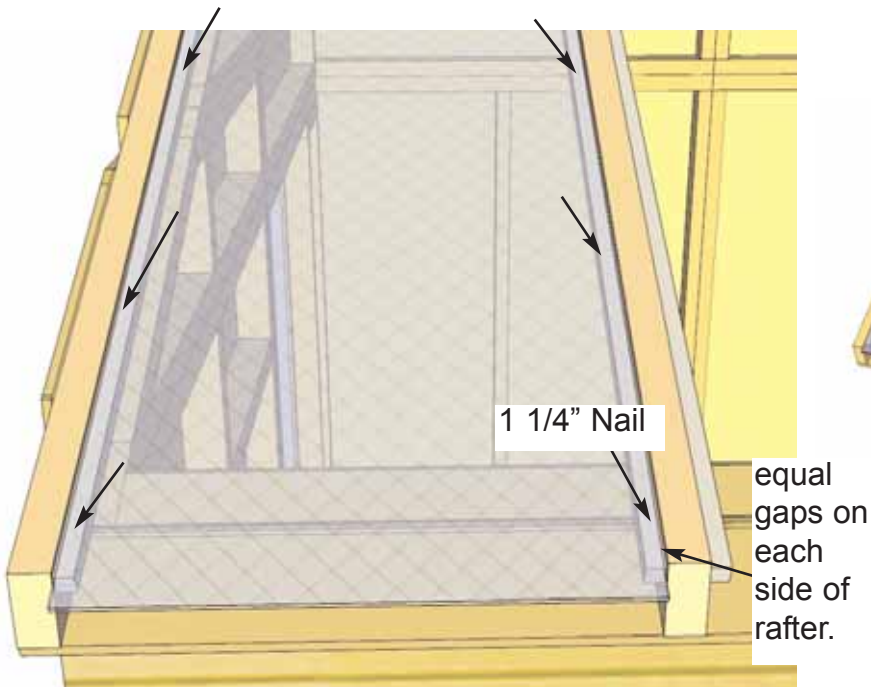

70. Position and secure 2nd Lexan Panel as per **Steps 67-69**.

69. Position Lexan Panel with equal gaps between rafters and overhanging the end of rafters by 1". With 6 - 1 1/4" nails, secure panel to Lexan Support Cleats.



71. Complete installation of remaining Lexan Panels.

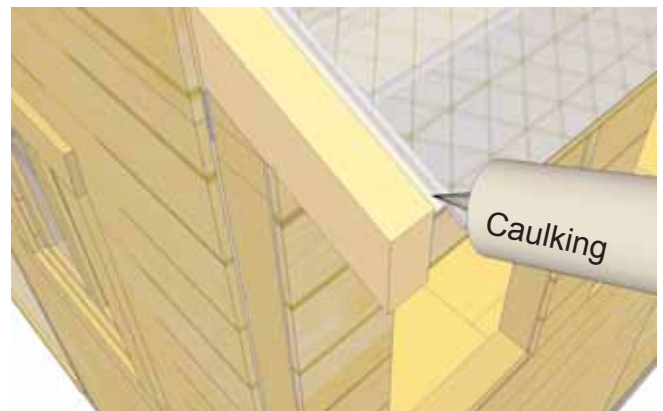

72. With a Caulking Gun, apply Silicon to seal gaps between rafters and Lexan Panels. Apply **Silicon** down each side of rafter. Use liberal amounts to properly seal the joint.

D. Miscellaneous Section

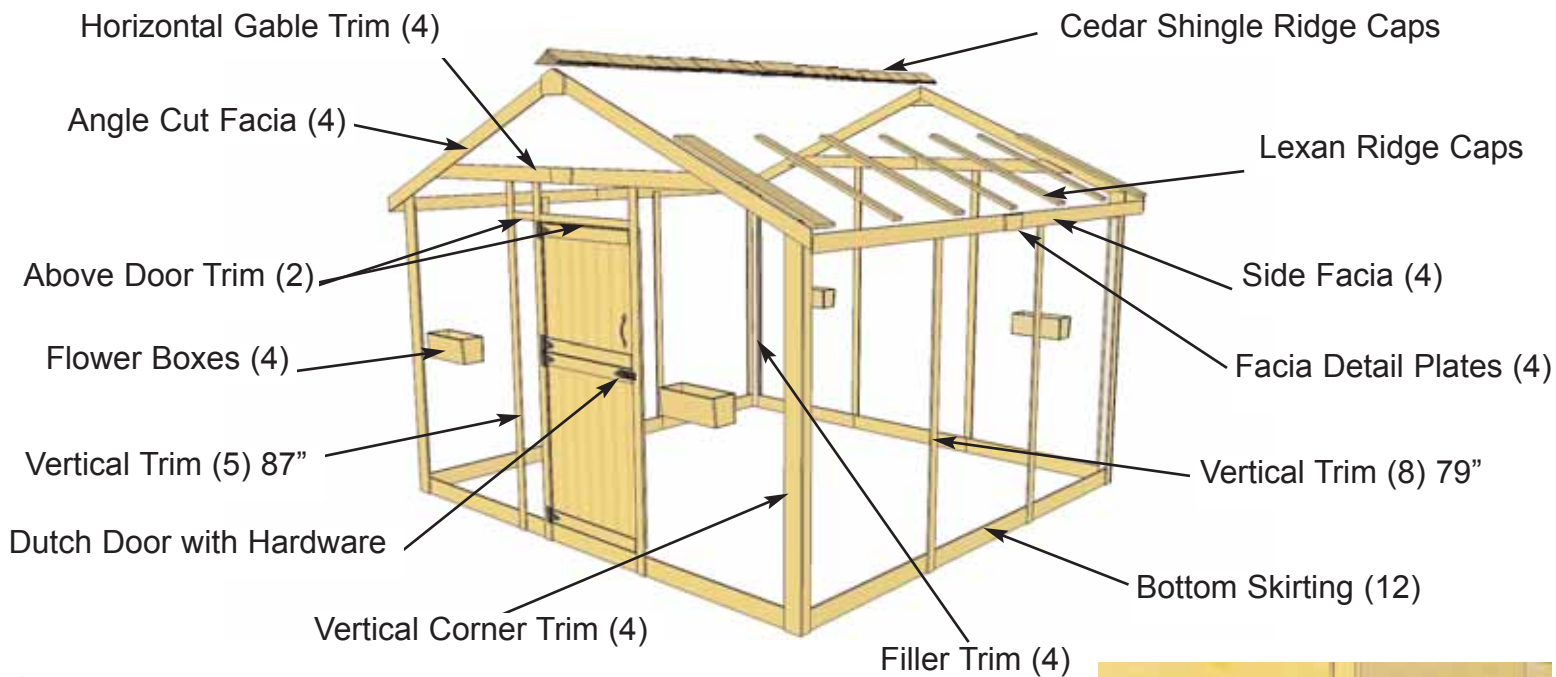

73. Attach Bottom Skirting

around the base of the shed. Skirting will hide floor framing. Gaps on outside will be covered by Wide Trim pieces later. Start with front and rear skirting pieces first and attach with 4 - 1 1/4\" finishing nails per piece.



3 pieces of Bottom Skirting for front and rear. 3 pieces for sides.

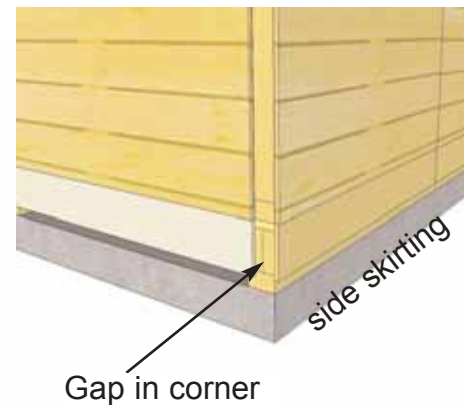

Gap in corner

Attach additional 2- 1 1/4\" screws on bottom outside edge of each windowless wall panel to further secure bottom siding to framing. **Note:** Corner Trim will cover screws in **Steps 80 - 82**. Drill pilot holes in siding to prevent splitting.

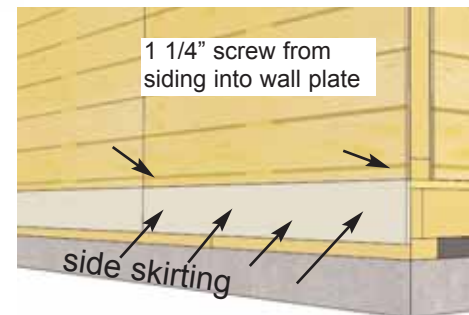

1 1/4\" screw from siding into wall plate

side skirting

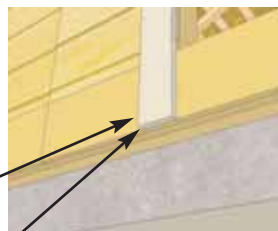
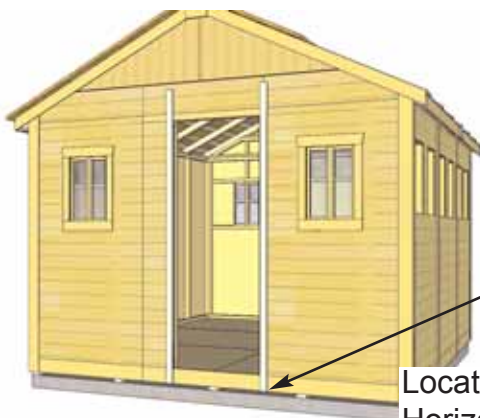

Location determined using Horizontal Gable Trim.

74. Position 2 Door Trims (2 - 1/2\" x 2 1/2\" x 87\")

on each side of door opening. Right side will sit flush with inside of Door Jamb. Left side will sit flush on edge of Narrow wall. Do a dry run with the Horizontal Gable Trim (**Step 92 & 93**) to determine vertical location of Trims. Attach with 8 - 1 1/4\"

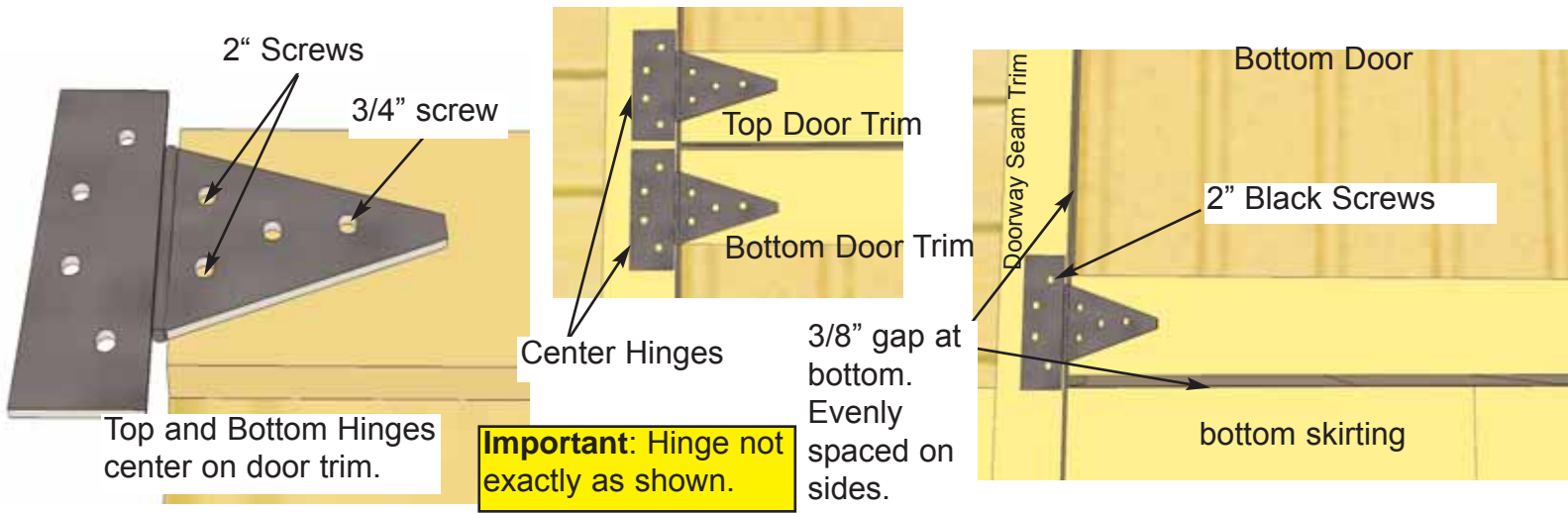

75. Attach Door Hinges to **Top** and **Bottom Dutch Door** sections. Center Hinges should be positioned to edge of door trim to prevent hinges from contacting each other while top and bottom hinges may be centered on door trim. Use 2" & 3/4" black screws on hinge / door attachment as shown above.

76. Place Bottom Dutch Door panel into position, gap 3/8" on bottom and evenly spaced on sides and attach hinge to doorway seam trim with 2" black screws. Use shim to help keep the door evenly spaced on bottom. One of the extra roof shingles (see parts list) can be used.

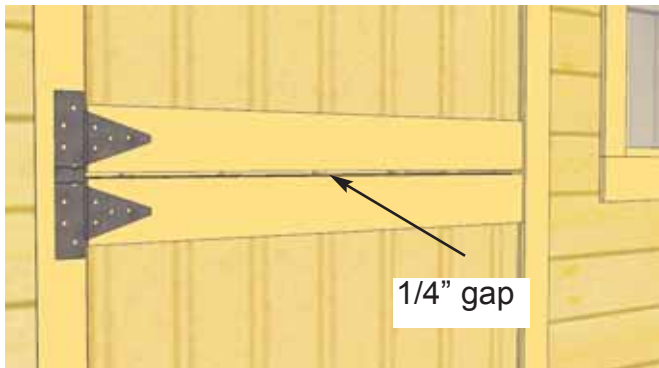

77. Place the Top Dutch Door Panel into place and gap top and bottom panel 1/4" apart. Use a shim once again to help you. Attach hinges to trim with hinge hardware provided.

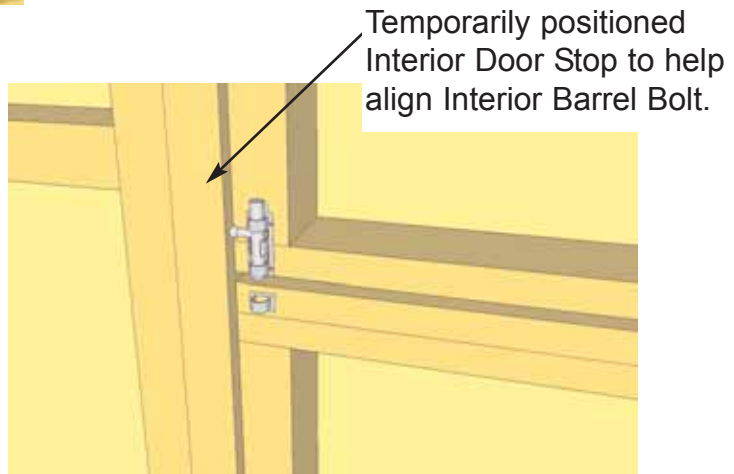

78. Attach **Door Handle**, **Exterior Barrel Bolt** and **Interior Barrel Bolt** to door. Handle is positioned on top door, Barrel Bolt on bottom door and Interior Barrel Bolt (silver) to top door stud. Attach Black Barrel Bolt as illustrated above with 3/4" Black Screws. Note how female part of Barrel Bolt is positioned higher than male. Do a dry run first to position Barrel Bolt correctly. **Important** - Drill pilot holes with 1/8" drill bit prior to securing with screws to prevent wood splitting.

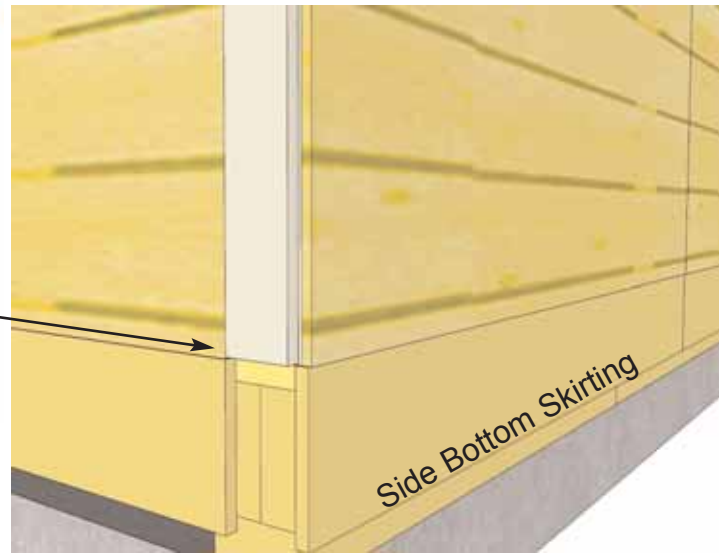

79. Attach **Filler Trim** - (4 - 1/2" x 2 1/2" x 75") to front and rear walls in each corner. Hammer with 8 - 1 1/4" finishing nails. Strips are positioned flush with siding and bottom skirting.

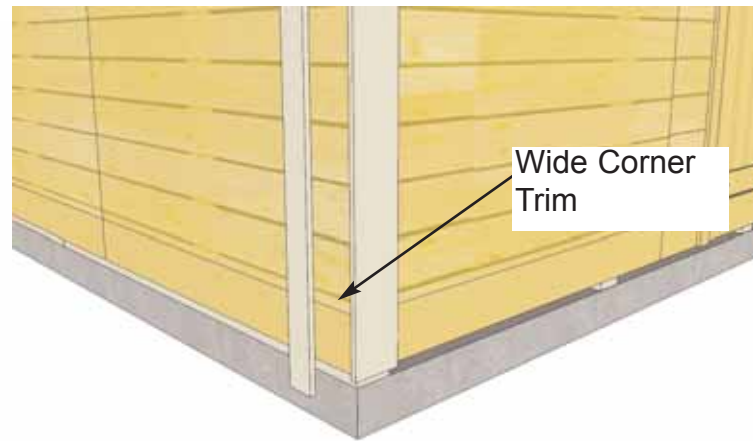

80. Attach **Wide Corner Trim** and **Narrow Trim** in each corner. Wide Trims are 4 1/2" wide. Narrow Trims are 2 1/2" wide. Butt Narrow Trim against the back of a Wide Corner Trim as shown in **Step 81**.

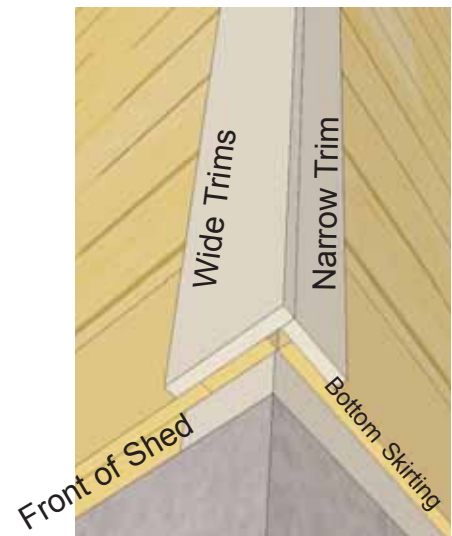

81. Position Trim flush with Bottom Skirting. When correctly aligned, attach with 8 - 1 1/4" finishing nails per piece. . Complete remaining Corner Trim attachment.



82. Attach **Narrow Wall Trims** around the Sunshed. Narrow trims are used where wall panels come together and leave a seam. **Note:** the Narrow Trim on the Short Wall side is only 79" long. Attach with 8 - 1 1/4" finishing nails per piece. Align Trim so flush at bottom of bottom skirting.

Outside (2)
5 1/2" wide

Center (2)
3 1/2" wide

Mid (3)
2 1/2" wide

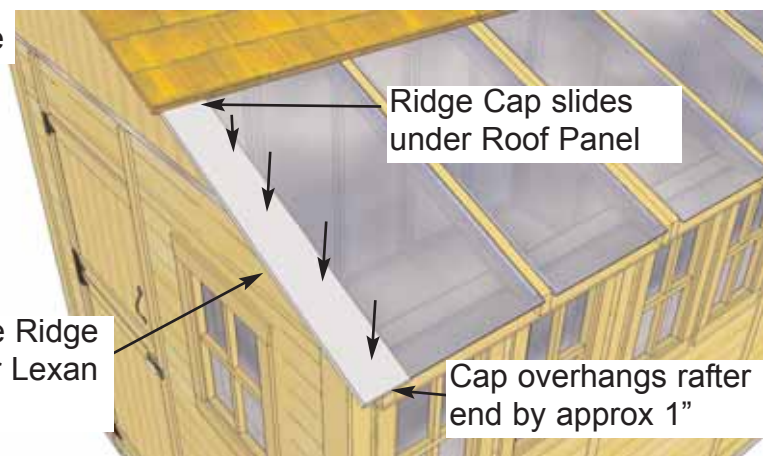
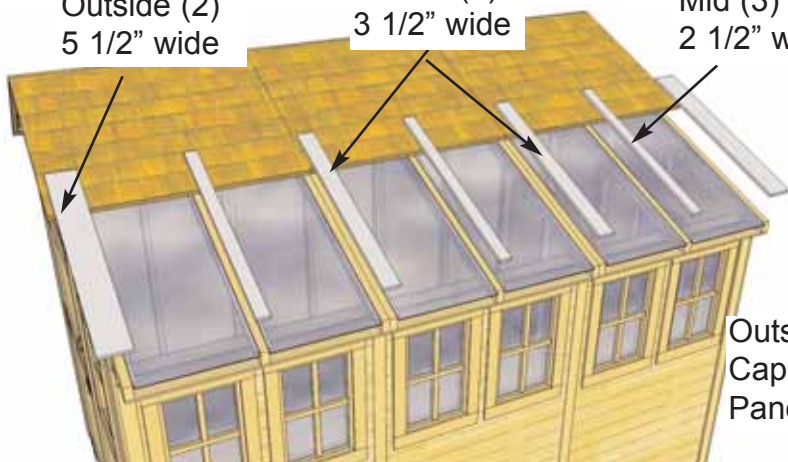

83. Locate all **Ridge Caps** for Lexan Panels (3 Mid / 2 Outside / 2 Center). Starting from the outside, position both 5 1/2" wide caps so outside edge is aligned with plywood of roof and Cap end slides under roof. When correctly aligned, attach Caps to center of outside rafter with 4 finishing nails. **See below.**

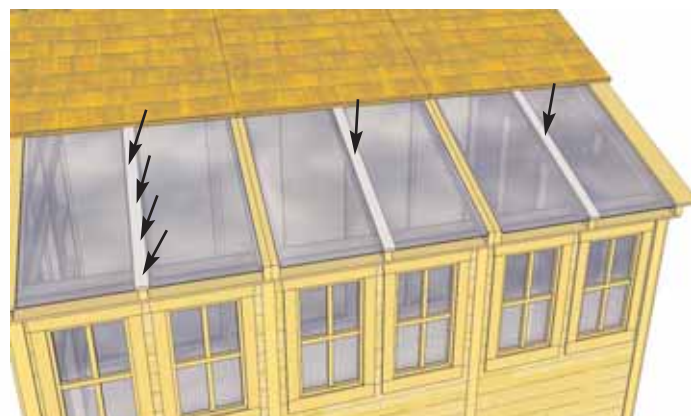
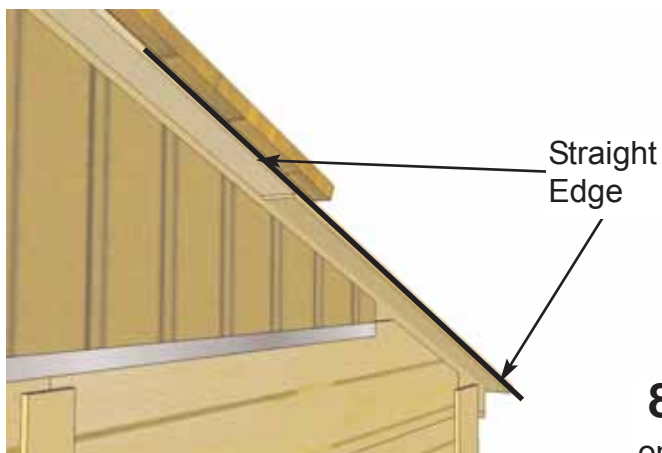

84. Position and attach Mid Ridge Caps evenly spaced on mid rafters. Align top to bottom as per **Step 83.**



85. Align and attach remaining Ridge Caps (3 1/2" wide) over Double Rafters as per Steps 83 & 84.



86. Attach **Front and Rear Facia** (angle cut on ends) to end of roof plywood. Starting with long Shingle Roof side, **line up a 82 1/8" long Facia piece so Facia end lines up with Plywood and Rafter ends.**

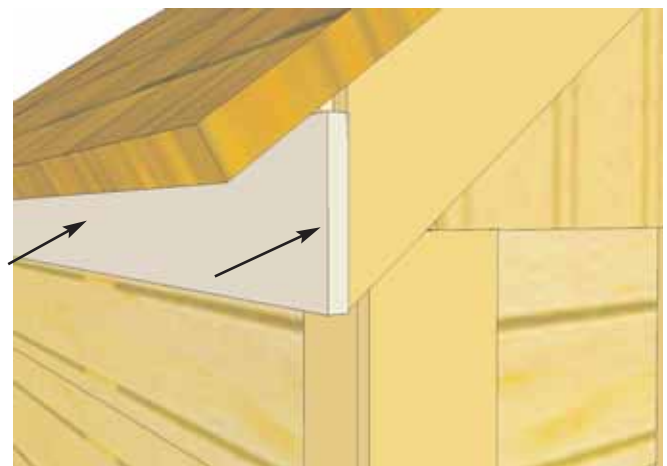

87. Attach **Side Facia** to roof rafter ends. There are 2 Side Facia pieces per side. Secure with 8 - 1 1/4" finishing nails per piece. Side Facia will sandwich Front and Rear Facia. Do a dry run with Front and Rear and Side Facia to confirm correct positioning prior to attaching.

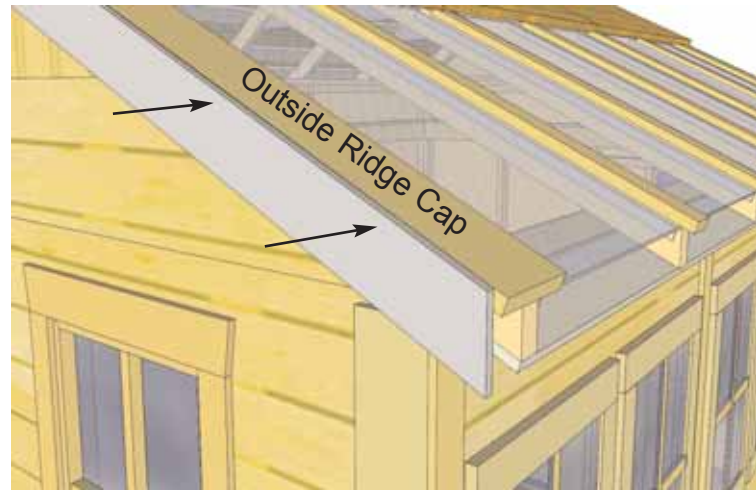

88. Attach remaining front and rear 82 1/8" long Facia boards to roof plywood and Outside Ridge Cap edge with 10 - 1 1/4" finishing nails and 2 - 1 1/4" screws. Use screws where Outside Ridge Cap and Facia meet. Once again, Line Facia up so it is aligned with rafter ends. Do a dry run with Front and Rear and Side Facia to confirm correct positioning prior to attaching.

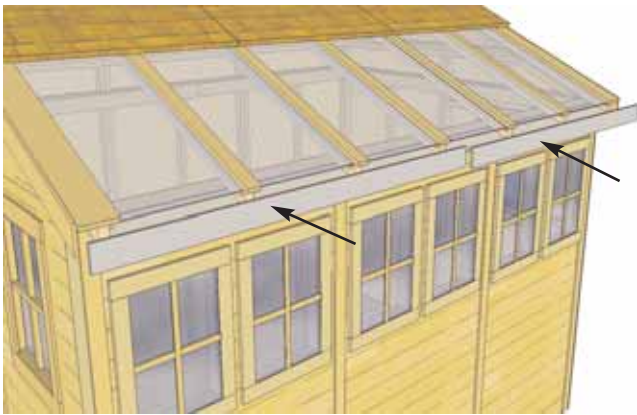

89. Attach remaining **Side Facia** to roof rafter ends as per **Step 87**.

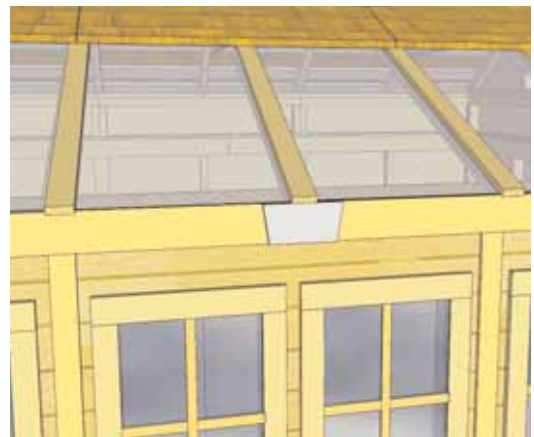

90. Attach **Facia/Trim Detail Plates** and **Pentagon Plates** to cover seam where Facia Trim pieces come together. Secure each with 4 - 1 1/4" finishing nails



91. Attach both the **Horizontal Door Trim (32")** and **Horizontal Narrow Wall Trim (8")** with 4 and 2 - finishing nails.



Angle cut on 1 end

92. Locate **Horizontal Gable Trims** for both front and rear of shed. Position equally over gable and wall seam.

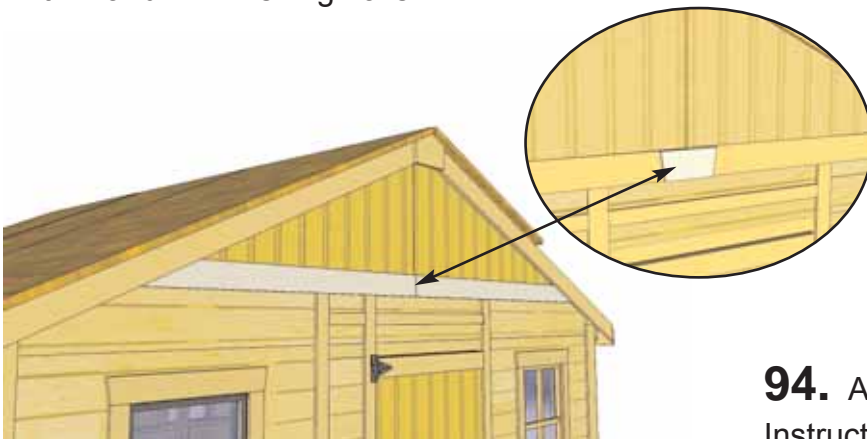

93. Use 8 - 1 1/4" finishing nails per piece to secure. Complete Rear. Attach **Facia Detail Plates** over Horizontal Gable Trim seam and attach with 4 - 1 1/4" finishing nails.



94. Assemble **Flower Box Kit** with Assembly Instructions found in each Flower Box Kit. Position completed Flower Box below bottom of window trim and secure with 2 - 2" screws per box. Screw from inside of box into the center wall stud. Attach second screw 2" underneath first screw and once again into the wall stud. Install Flower Box Kits underneath each window.

Alternate Ridge Cap Seams (Offsetting angle cut at peak)

Important- Butt (thick) end of Ridge Cap will be facing towards the outside of shed.

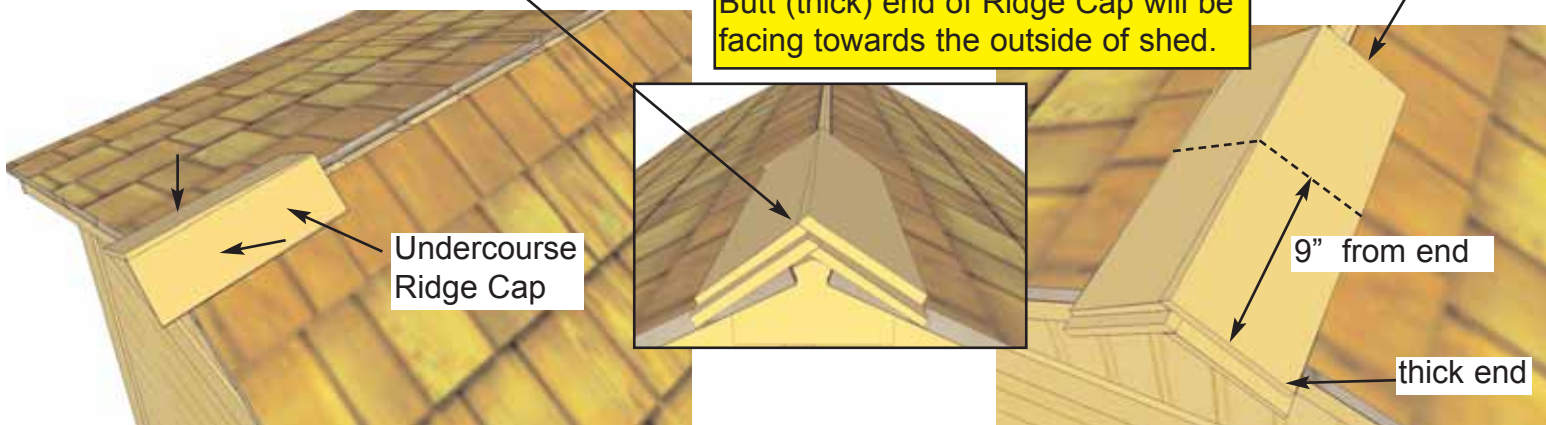

95. Place First Roof Ridge Cap (Lower Grade Undercourse Ridge Cap) on roof peak overhanging shingles by approximately 1". Attach with 2- 1 1/4" Shingle Nails 9" from end. Place 2nd Ridge Cap 1" back from 1st cap. Attach with 2- 1 1/4" Shingle Nails 9" from end. Alternate each Ridge Cap as you proceed.

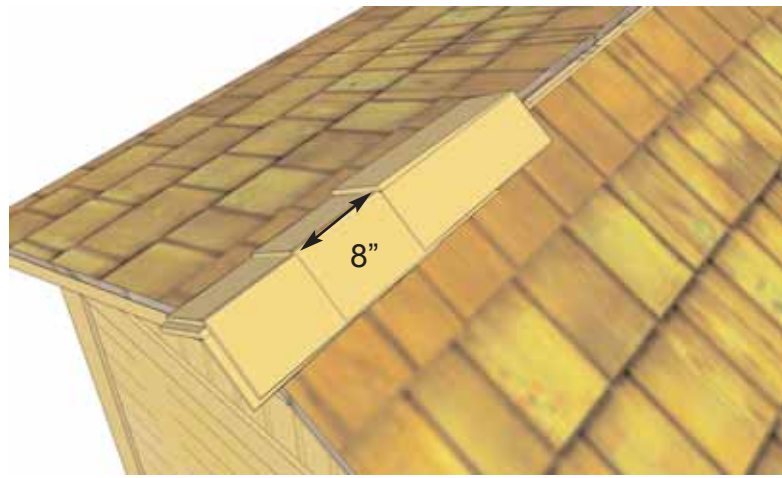
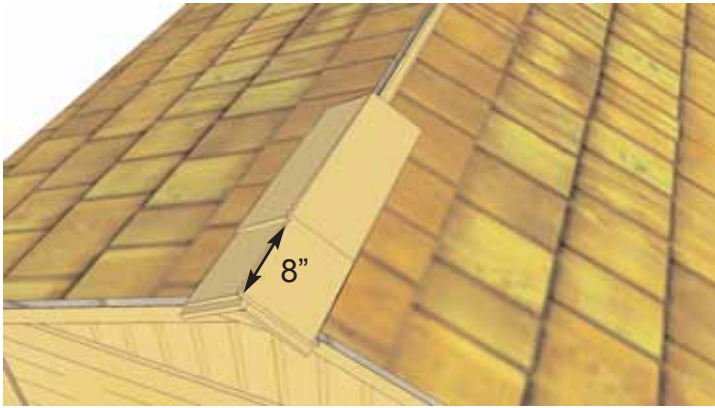

96. Place 3rd Ridge Cap 8" back from 2nd. (enough to cover shingle nails). Attach 3rd Ridge Cap down as per **Step 95**. Continue to position and attach Ridge Caps until half roof is complete.

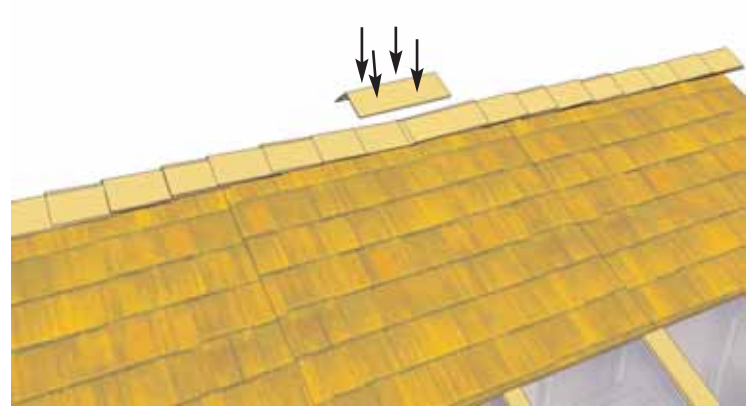
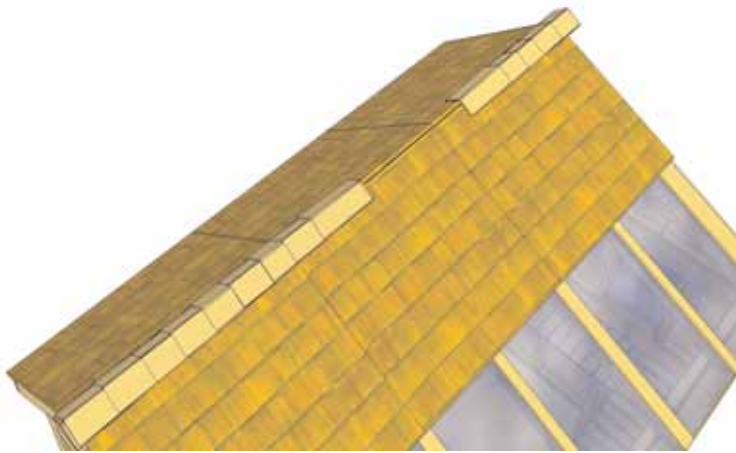

97. From opposite side, position and attach Ridge Caps as described above starting with the Undercourse Ridge Cap. Score/cut 1 Ridge Cap to 12" or to fit in the center of roof. Attach center cap with 4 - 1 1/2" Shingle Nails.

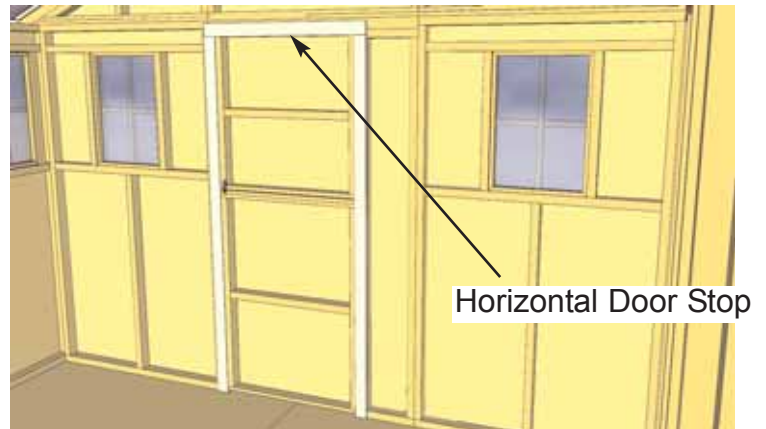
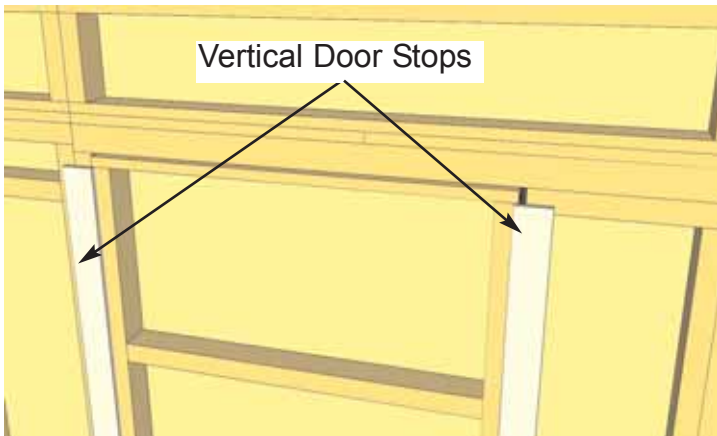

98. Attach Interior **Vertical and Horizontal Door Stops** to door framing from inside of shed. Use 4 - 2" screws to secure each Stop. Stops should overlap door by approx. 1/2"

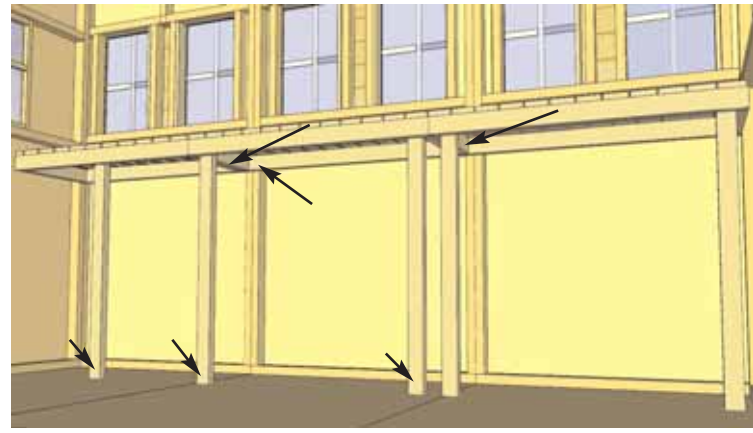
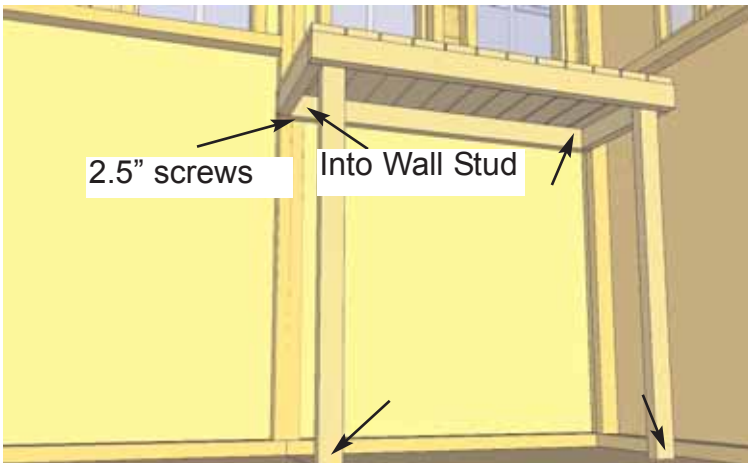

99. Locate 1 **Long Potting Shelf** and 2 Legs. Attach Legs in each front corner from the inside with 2 - 2.5" screws. Attach Shelf framing to wall studs with 2 - 2.5" screws. Place 2nd Long Potting Shelf and 2 Legs adjacent to Long Potting Shelf and attach together from underneath where end framings meet with 2 - 2.5" screws. Attach Long Shelf into Wall Stud with 1 - 2.5" screw from underneath. Place Short Potting Bench in corner and attach end framings together and also to wall studs with 4 - 2.5" screws. Attach 1 front center Leg.

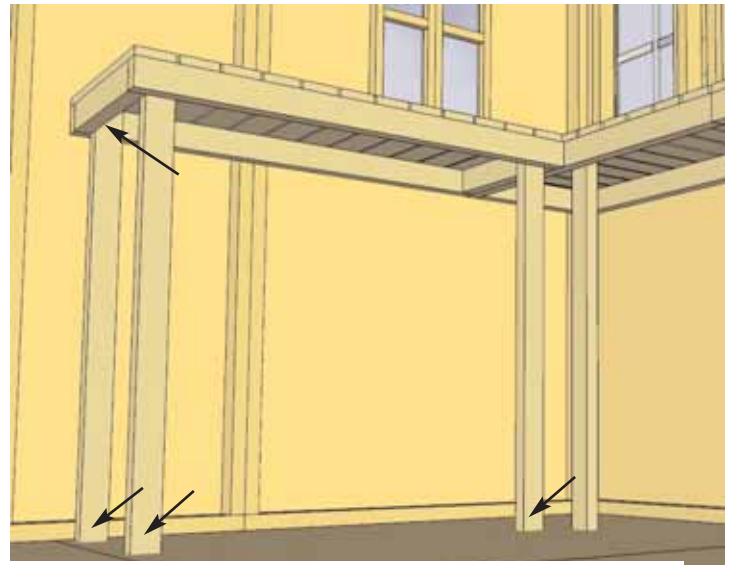
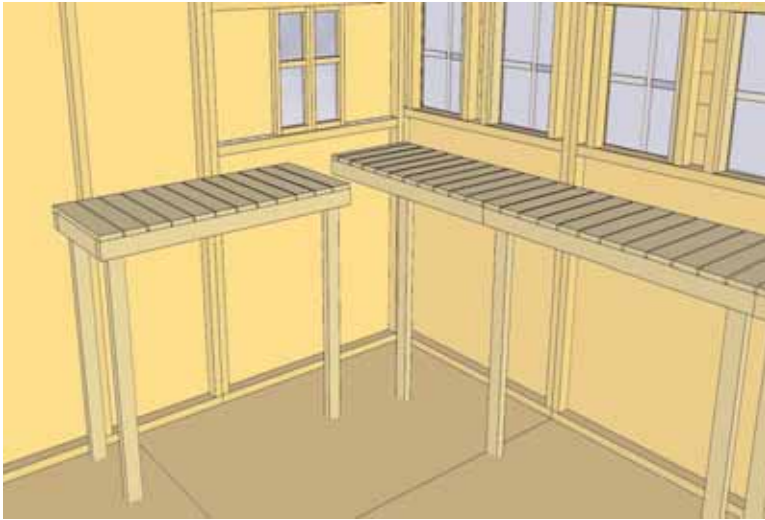

100. Locate 3rd Long Potting Shelf and 3 Legs. Attach Legs in front corners and outside rear corner with 2 - 2.5" screws/leg from underneath. Place in rear corner against Short Potting Shelf and attach together from underneath where framings meet with 2 - 2.5" screws. Attach Long Shelf into Wall Stud with 1 - 2.5" screw from underneath.

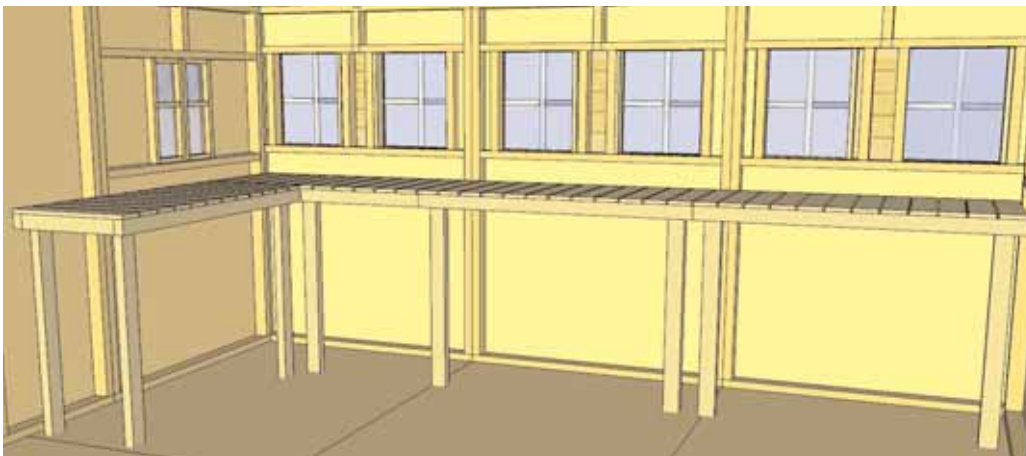

Completed
Potting Shelf
Setup.

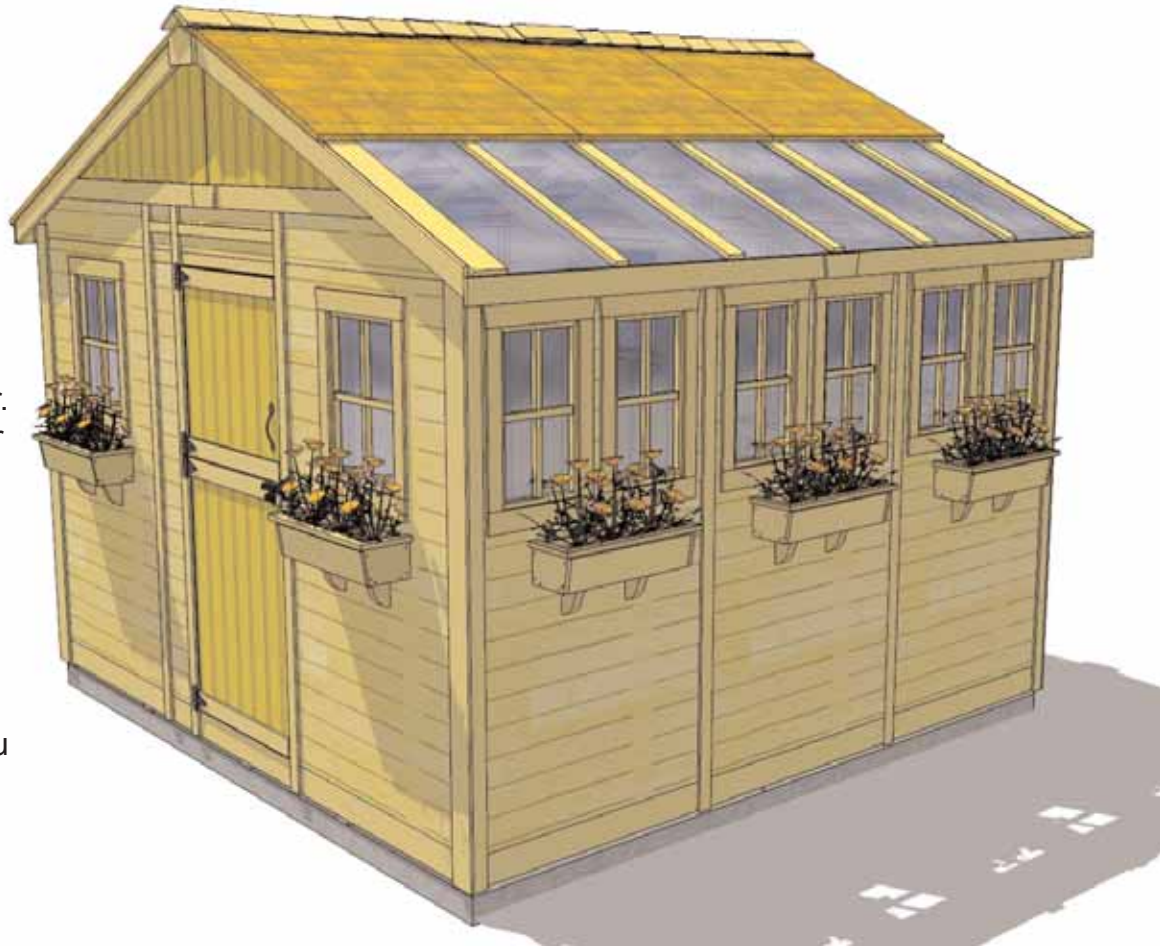

Note; Our Sheds are shipped as an unfinished product. If exposed to the elements, the western red cedar lumber will weather to a silvery-gray color. If you prefer to keep the cedar lumber looking closer to the original color, we suggest that you treat the wood with a good oil base wood stain. You may also wish to paint your new shed rather than stain it. In both cases we recommend that you consult with a paint and stain dealer in your area for their recommendations.

We hope your experience constructing our building has been both positive and rewarding.

We value your feedback and would like to hear back from you on how well we are doing in the following areas:

1. **Customer Service**
2. **On Time Shipping**
3. **Motor Freight Delivery**
4. **Quality of Materials**
5. **Assembly Manual**
6. **Overall Satisfaction.**



The materials contained in this Assembly Manual may be downloaded or copied provided that ALL copies retain the copyright and any other proprietary notices contained on the materials. No material may be modified, edited or taken out of context such that its use creates a false or misleading statement or impression as to the positions, statements or actions.

Please call, write or email us at:

Outdoor Living Today

Canadian Address
9393 287th Street
Maple Ridge, British Columbia
Canada V2W 1L1

United States Address
P.O. Box 96
Sumas, Washington
USA 98295