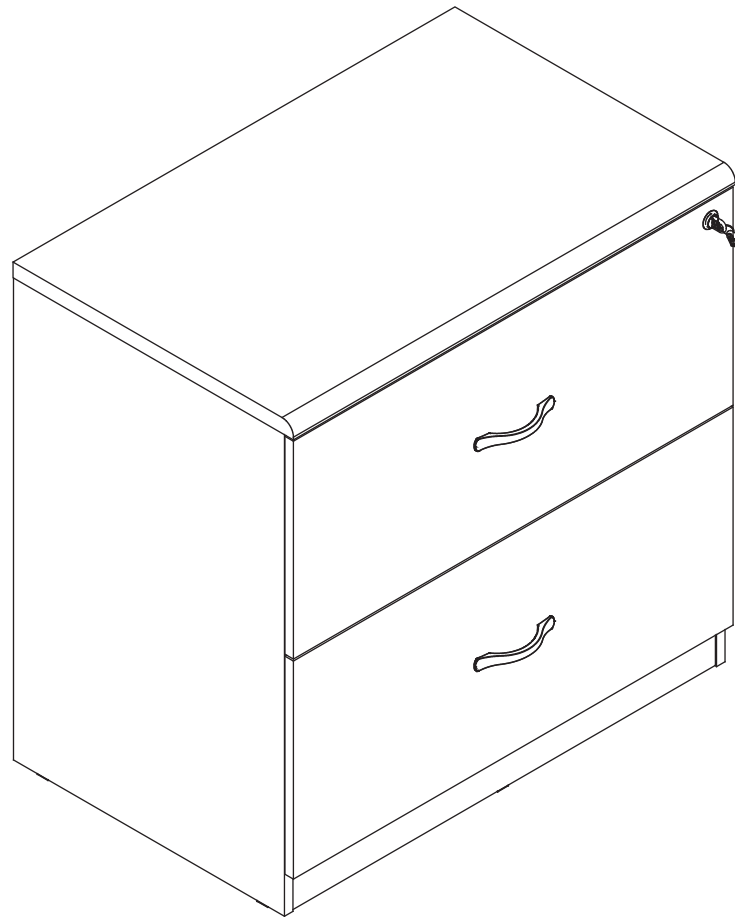




home & office
furniture

22112



Thank you for purchasing this quality product. Please be sure to check all packing material carefully for small parts which may have come loose inside the carton during shipment. Count all parts and hardware and compare with the parts list to be sure all parts are present. If any parts are missing or damaged, phone, fax or email to our Customer Service Department. For efficient and speedy service please indicate the model number and code letter of part(s) needed.

If you have any damaged or missing parts please contact us at:

OS Home & Office Furniture

1011a Gulf

Lamar, MO 64759

417 682 5522

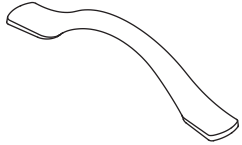
417 682 5524 fax

Osconsumerservice@sbcglobal.net

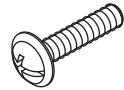
IMPORTANT NOTE: Follow instructions listed below in proper sequence as numbered to assure fast, easy and correct assembly.

hardware

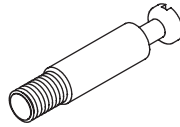
(P) x 2
drawer pull



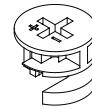
(Q) x 4
3/4"round-head screw



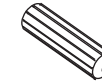
(R) x 10
big cam bolt



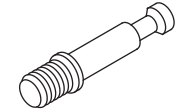
(S) x 10
big cam lock



(T) x 8
1 1/4"x 1/4"dia wood
dowel with ridges



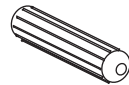
(U) x 10
small cam bolt



(V) x 10
small cam lock



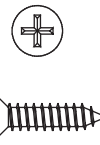
(W) x 24
1 1/4"x 3/8"dia wood
dowel with ridges



(X) x 4
three ball bearing slide



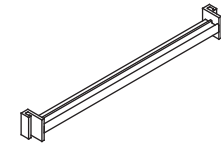
(Y) x 42
1/2"flat-head screw



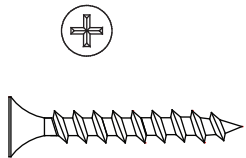
(Z) x 2
glue



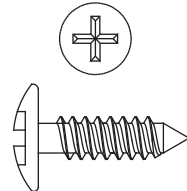
(Aa) x 4
plastic file hanger



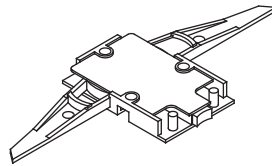
(Bb) x 10
1 3/8"flat-head screw



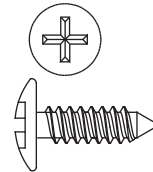
(Cc) x 2
1/2"round-head screw



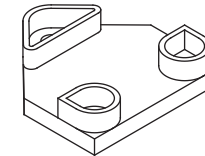
(Dd) x 1
anti-tip hardware



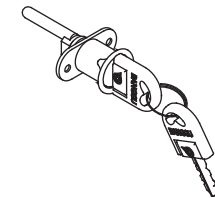
(Ee) x 14
9/16"round-head screw



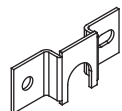
(Ff) x 2
plastic anti-tip hardware



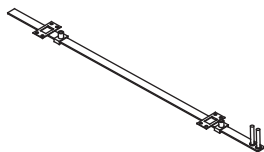
(Gg) x 1
lock



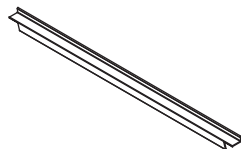
(Hh) x 2
lock plate



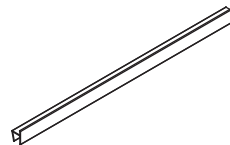
(Ii) x 1
lock bar



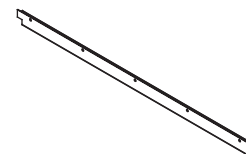
(Jj) x 4
plastic file hanger



(Kk) x 2
plastic file hanger

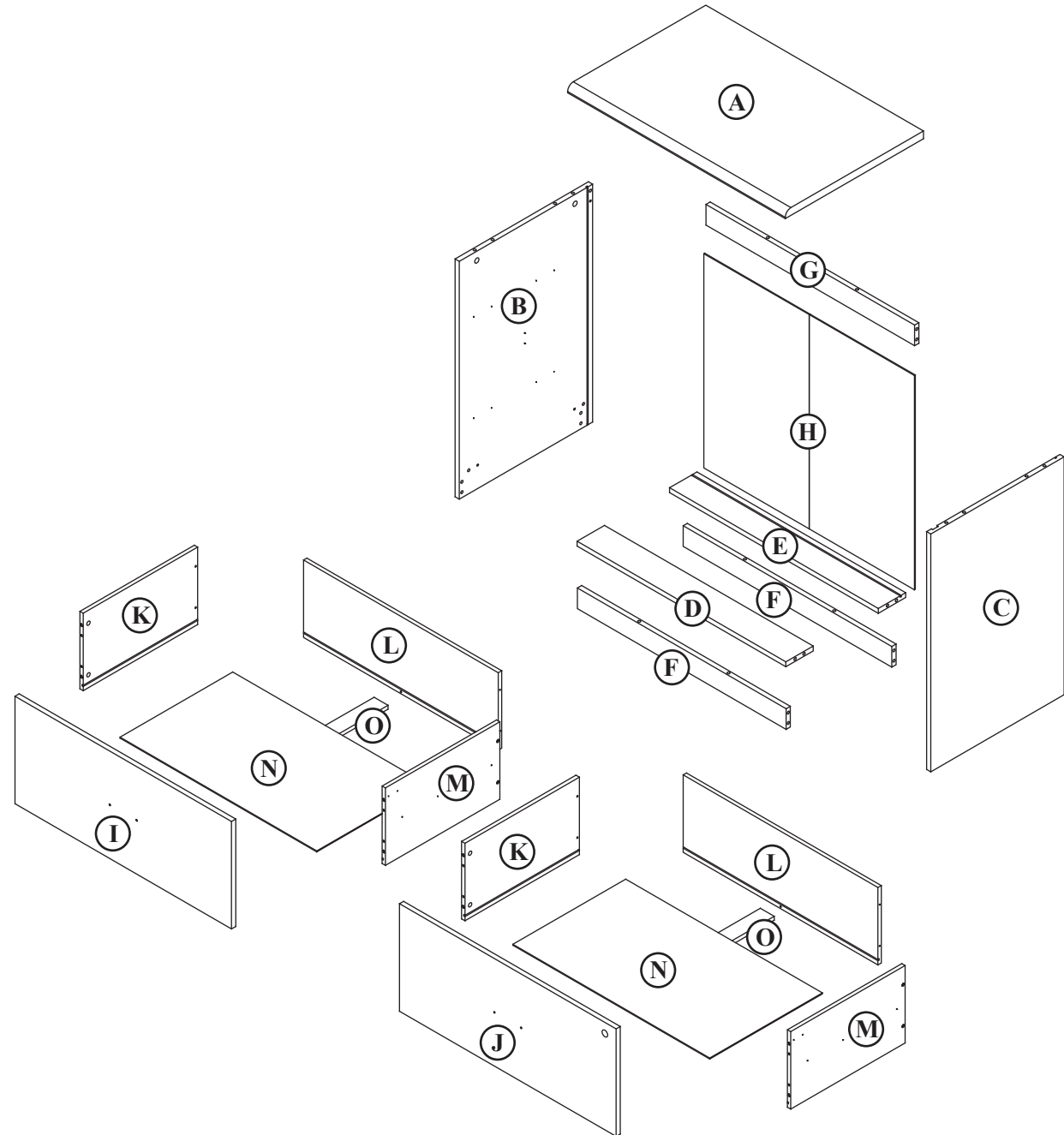


(Ll) x 2
plastic file hanger

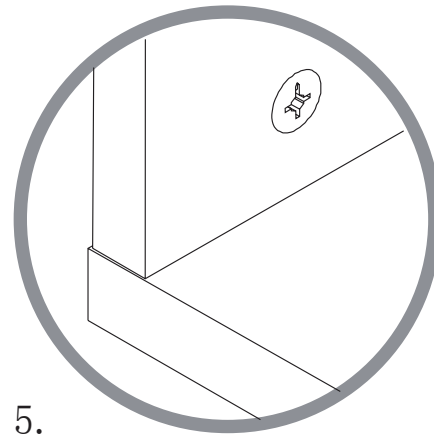
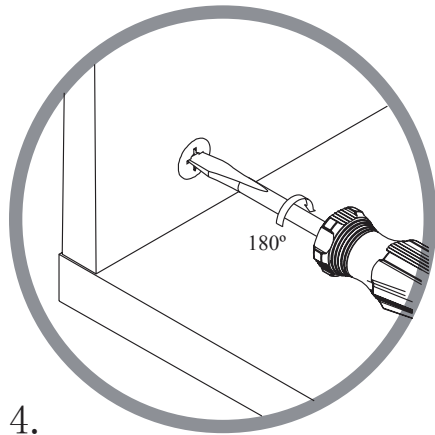
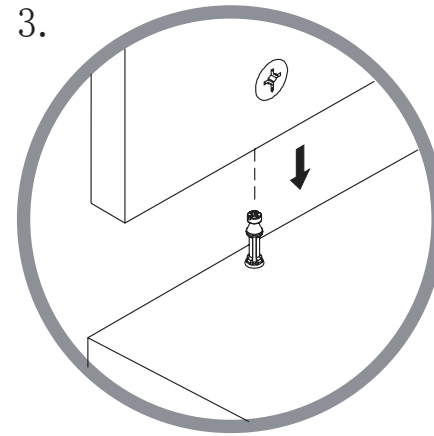
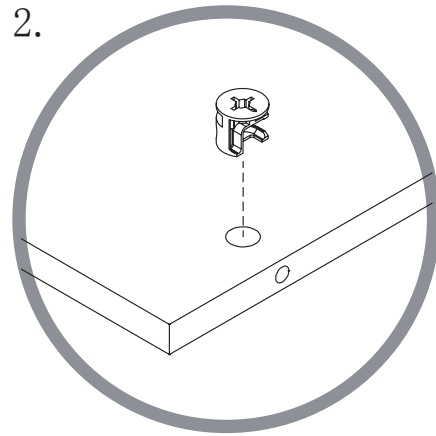
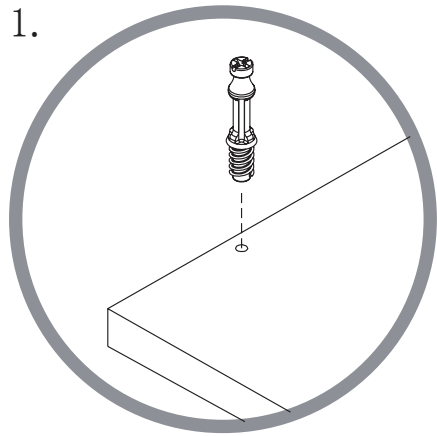


ITEM DESCRIPTION QUANTITY

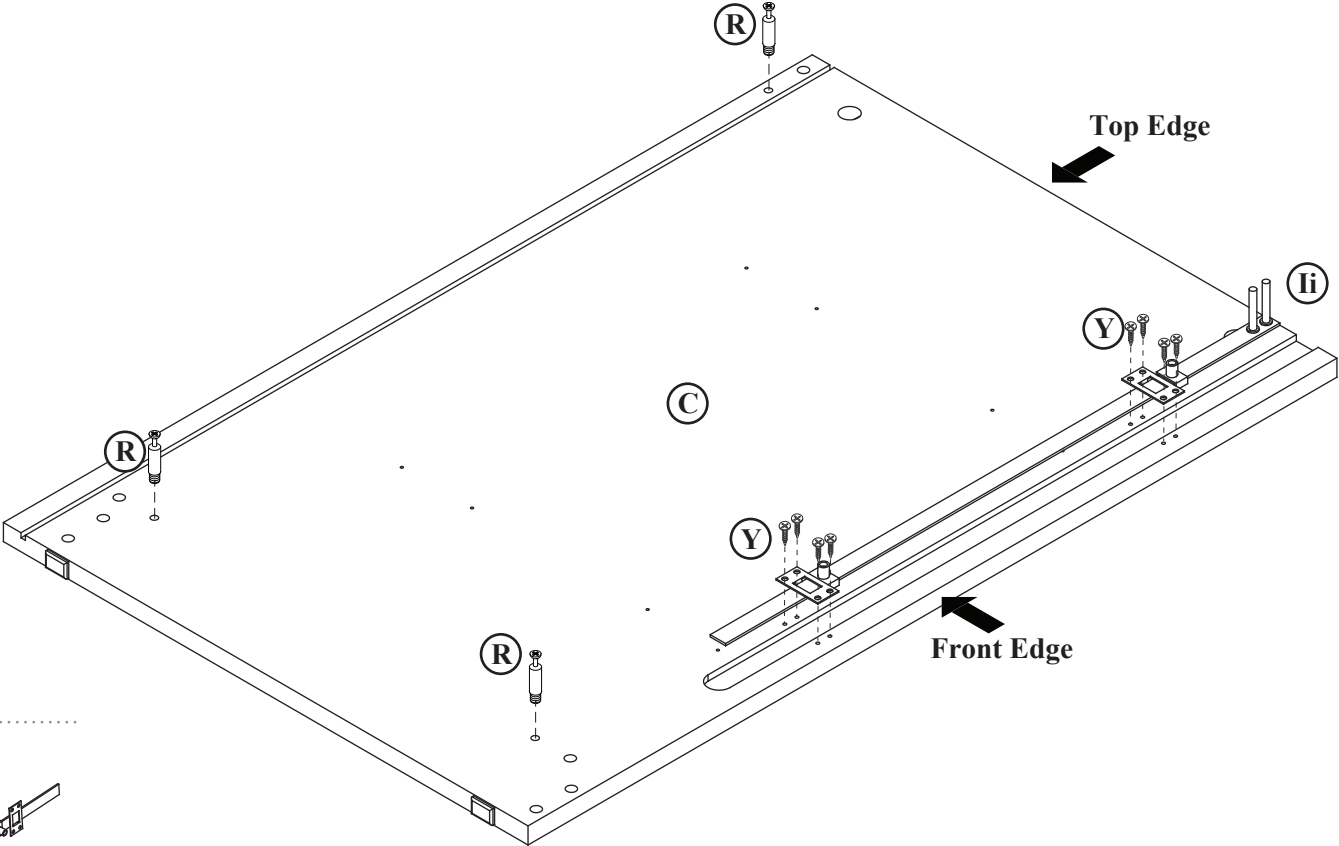
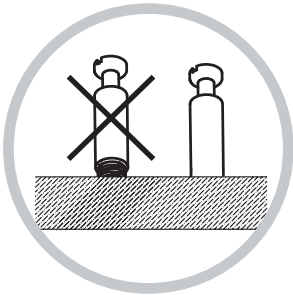
ITEM	DESCRIPTION	QUANTITY
A	top panel	1
B	left panel	1
C	right panel	1
D	bottom panel	1
E	bottom panel	1
F	bottom rail	2
G	back rail	1
H	back panel	1
I	lower drawer front	1
J	upper drawer front	1
K	drawer left	2
L	drawer back	2
M	drawer right	2
N	drawer bottom	2
O	drawer support rail	2
P	drawer pull	2
Q	3/4"round-head screw	4
R	big cam bolt	10
S	big cam lock	10
T	1 1/4"x 1/4" dia wood dowel with ridges	8
U	small cam bolt	10
V	small cam lock	10
W	1 1/4"x 3/8"dia wood dowel with ridges	24
X	three ball bearing slide	4
Y	1/2" flat-head screw	42
Z	glue	2
Aa	plastic file hanger	4
Bb	1 3/8" flat-head screw	10
Cc	1/2"round-head screw	2
Dd	anti-tip hardware	1
Ee	9/16"round-head screw	14
Ff	plastic anti-tip hardware	2
Gg	lock	1
Hi	lock plate	2
Ii	lock bar	1
Jj	plastic file hanger	4
Kk	plastic file hanger	2
Ll	plastic file hanger	2



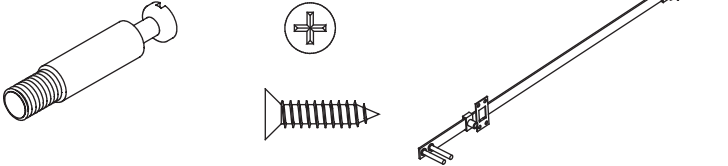
how to use the cam lock system



step 1.



- (R) x 3 big cam bolt
- (Y) x 8 1/2" flat-head screw
- (li) x 1 lock bar

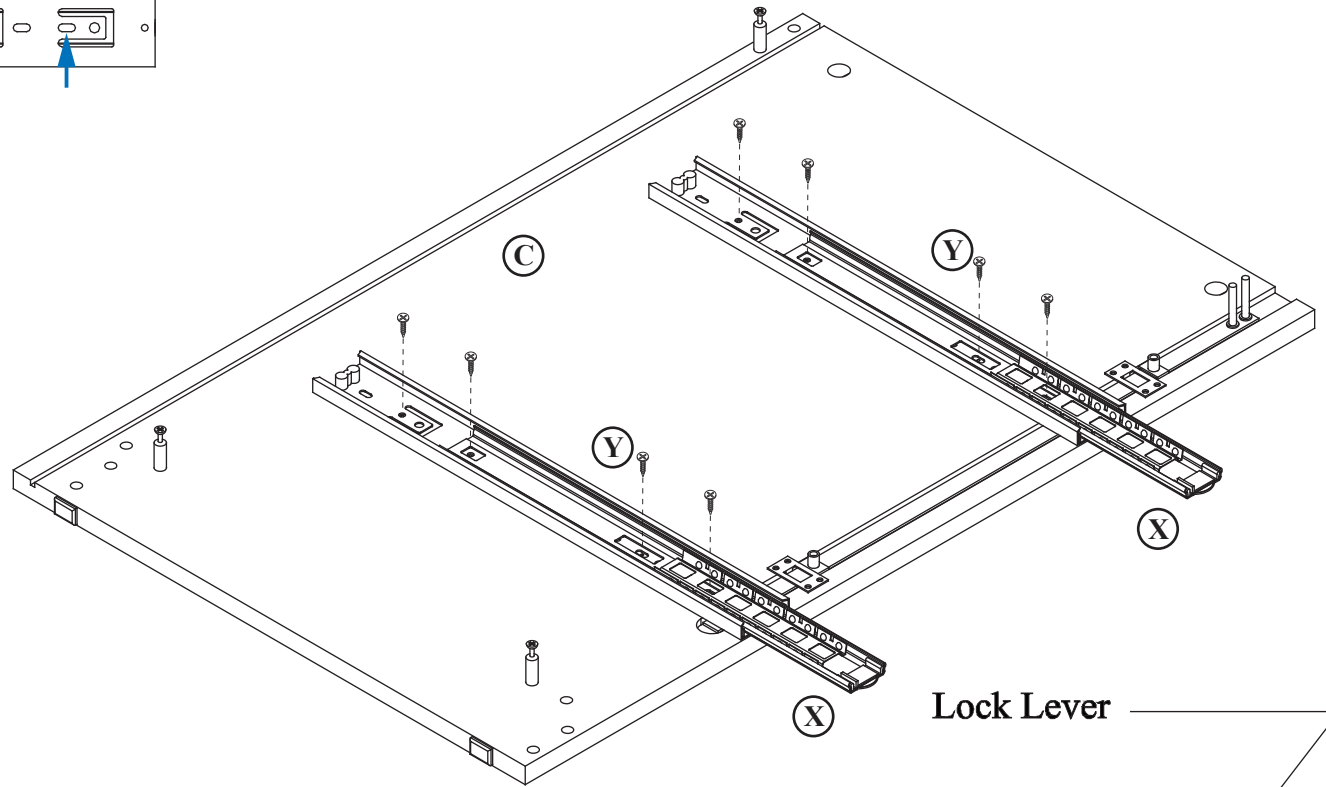


1. Install big cam bolts (R) into right panel C.
2. Install lock bar (li) using screws (Y).

step 2.

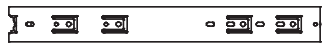


Diagram B



(X) x 2
three ball bearing slide

(Y) x 8
1/2" flat-head screw



Lock Lever

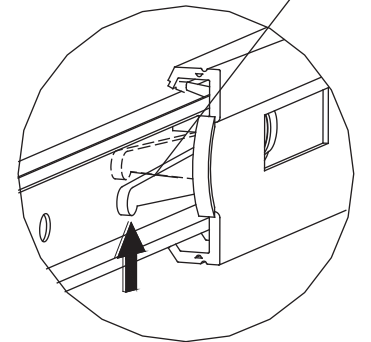


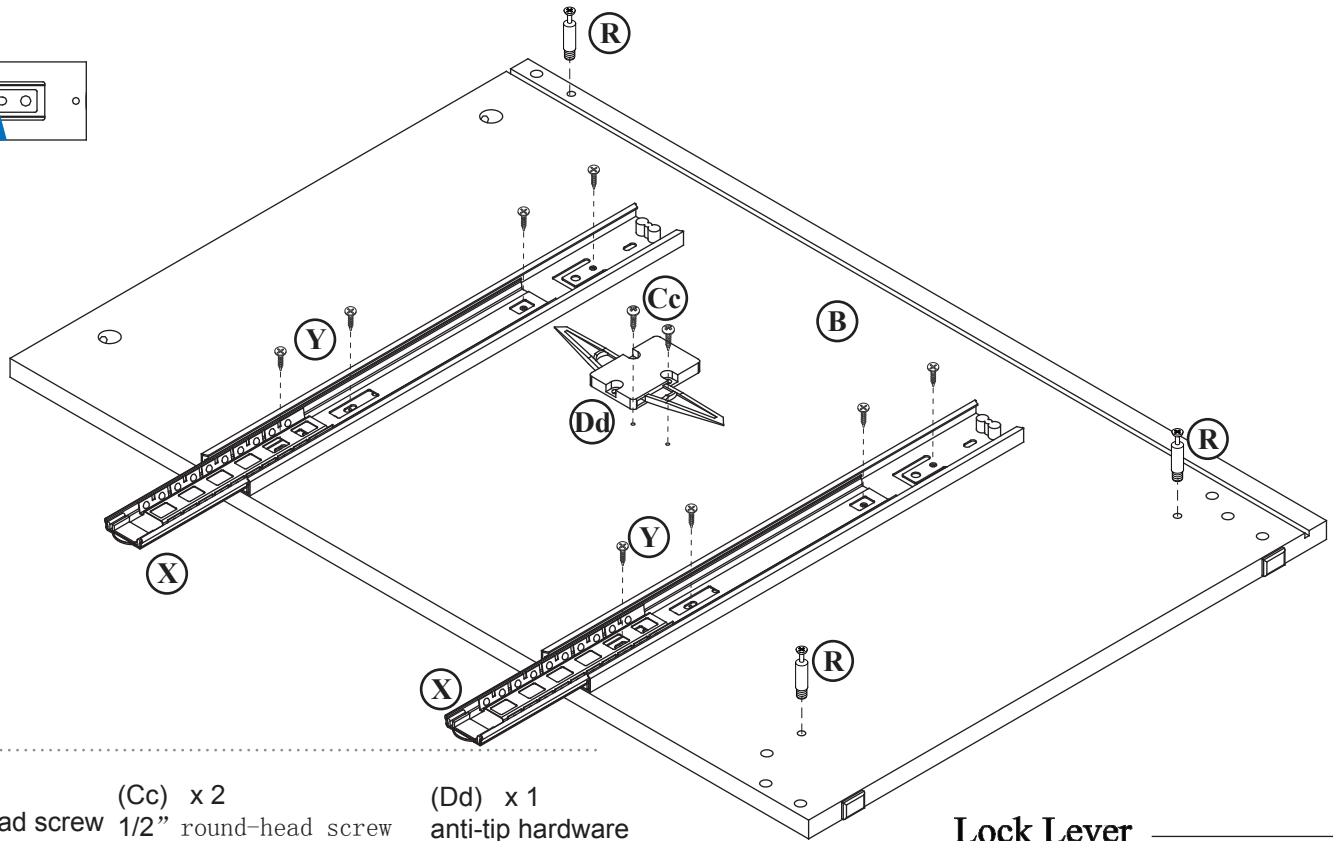
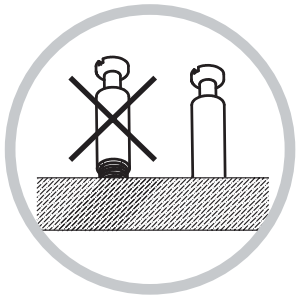
Diagram A

1. Separate the drawer slide by pressing lock lever as shown in diagram A.
2. Attach drawer slide to panel C using the holes noted in diagram B.

step 3.



Diagram B



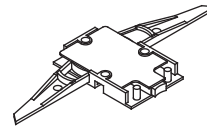
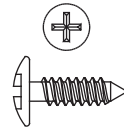
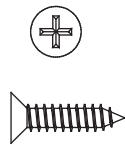
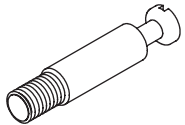
(R) x 3
big cam bolt

(X) x 2
three ball bearing slide

(Y) x 8
1/2" flat-head screw

(Cc) x 2
1/2" round-head screw

(Dd) x 1
anti-tip hardware



Lock Lever

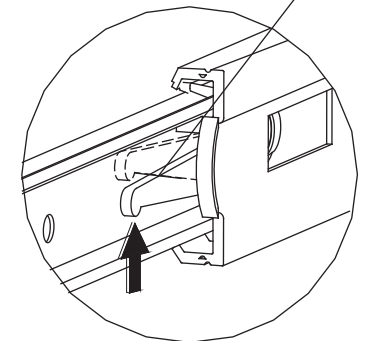
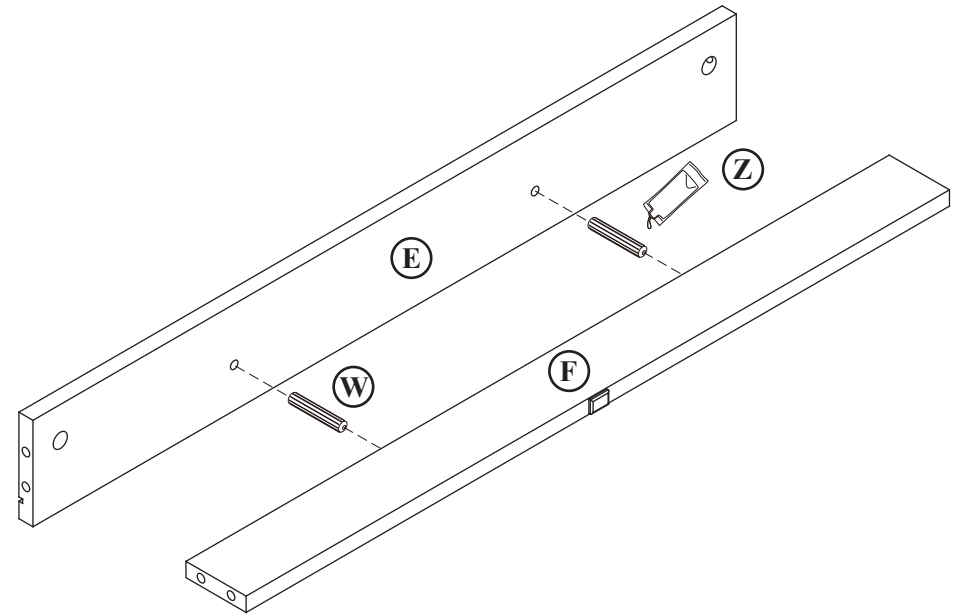
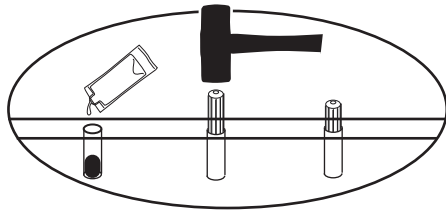


Diagram A

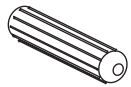
1. Attach big cam bolts (R) to left panel (B).
2. Attach drawer slides to panel (B) using the holes noted in diagram B.
3. Attach anti tip hardware (Dd) using screws (Cc).

step 4.



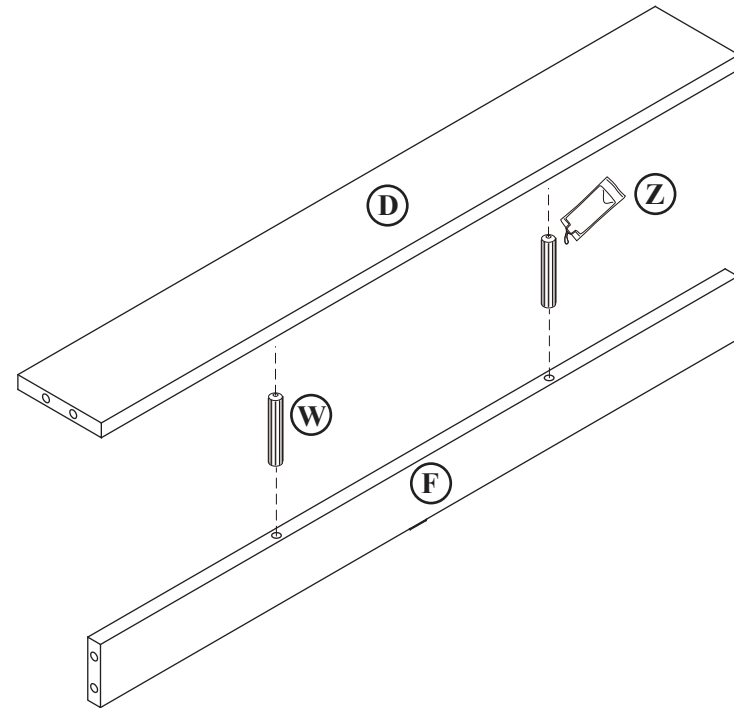
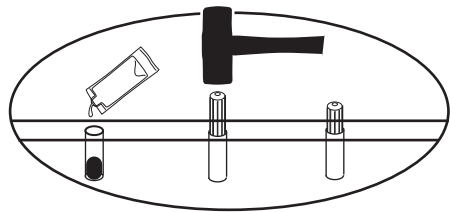
(W) x 2
1 1/4" x 3/8" dia wood
dowel with ridges

(Z) glue



1. Attach parts E and F using dowels & glue.

step 5.



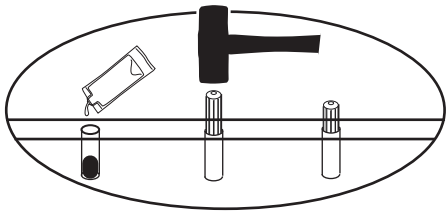
(W) x 2
1 1/4"x 3/8" dia wood
dowel with ridges

(Z) glue

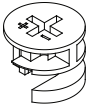


1. Attach parts D and F using dowels & glue.

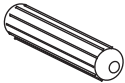
step 6.



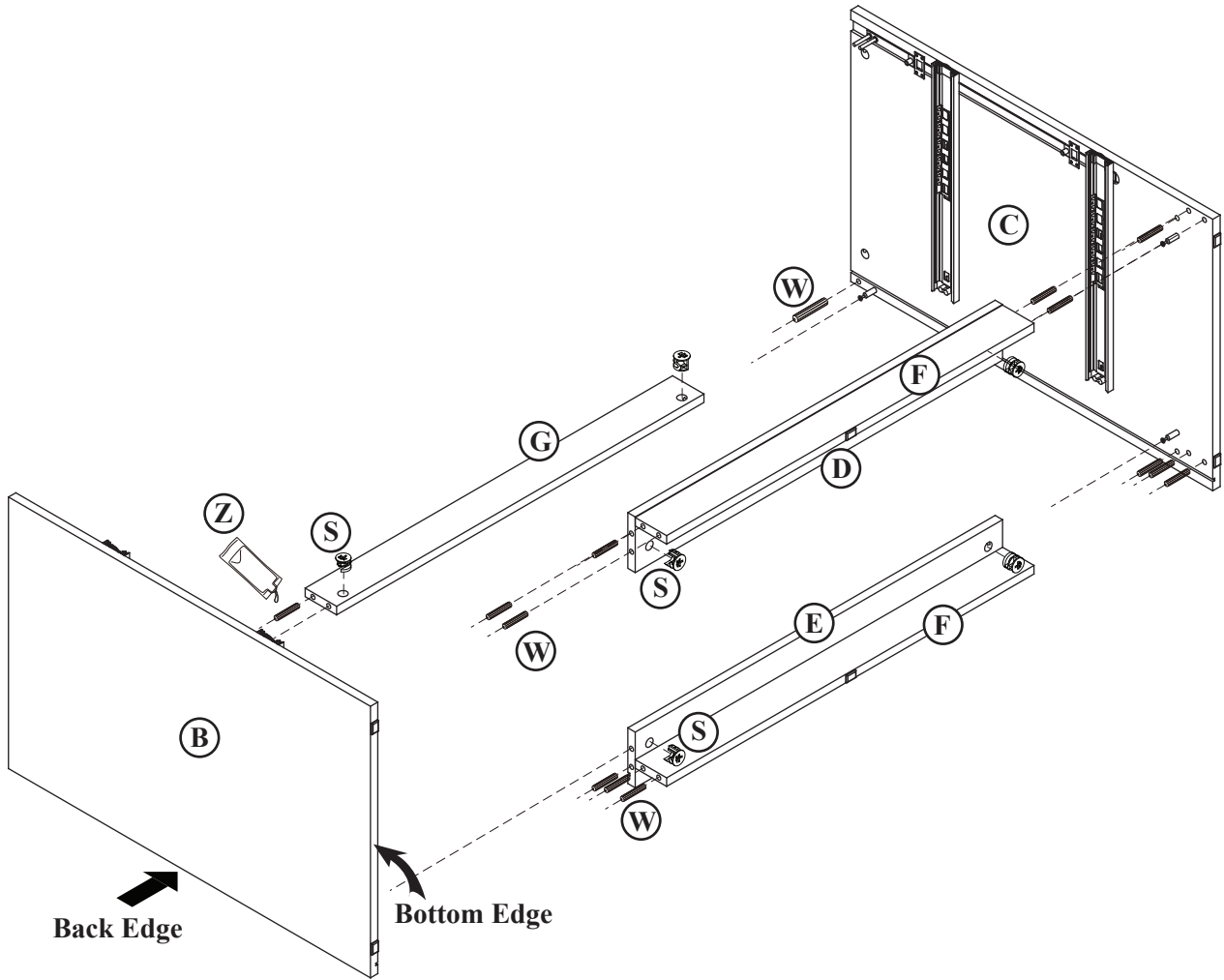
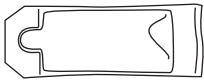
(S) x 6
big cam lock



(W) x 14
1 1/4" x 3/8" dia wood
dowel with ridges

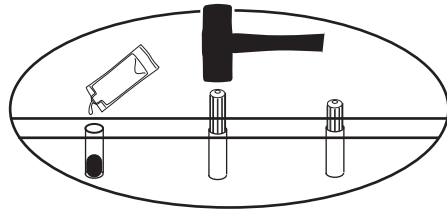
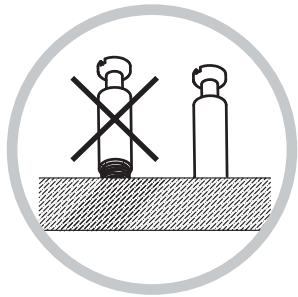


(Z) glue



1. Glue dowels into both ends of parts E, F, G and D.
2. Place big cam locks (S) into both ends of parts D, E and G.
3. Carefully assemble as shown, tightening cam locks as you go.

step 7.

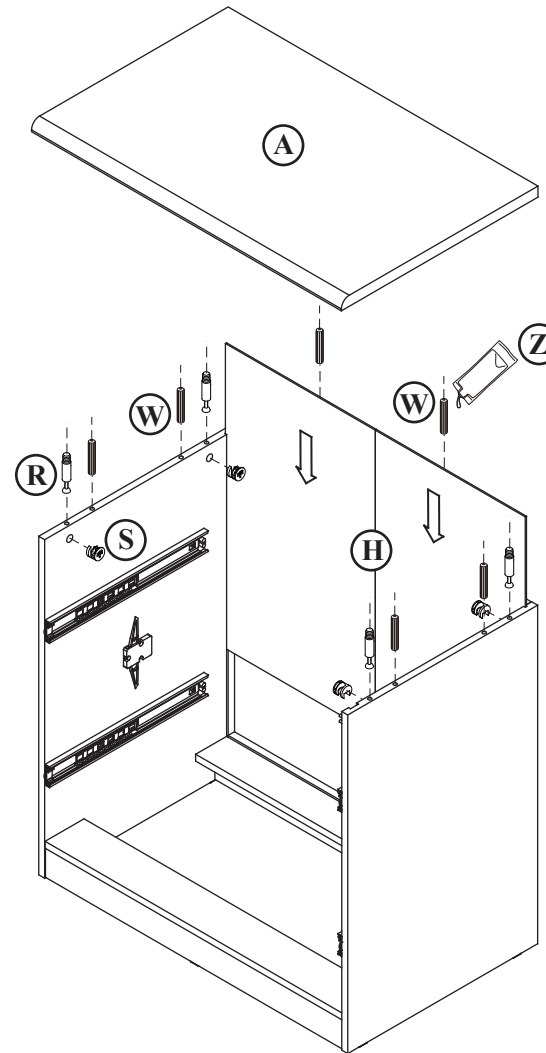
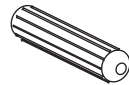
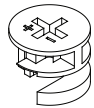
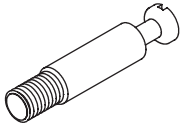


(R) x 4
big cam bolt

(S) x 4
big cam lock

(W) x 6
1 1/4" x 3/8" dia wood
dowel with ridges

(Z) glue



1. Slide back panel into grooves.
2. Insert big cam bolts (R) and glue dowels (W) into underside of top panel A.
3. Insert big cam locks (S) and a little glue into the top edge of left panel (B) and right panel (C).
4. Place top panel (A) into place and tighten cam locks.

step 8.

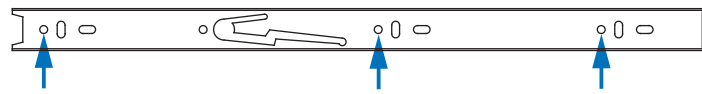
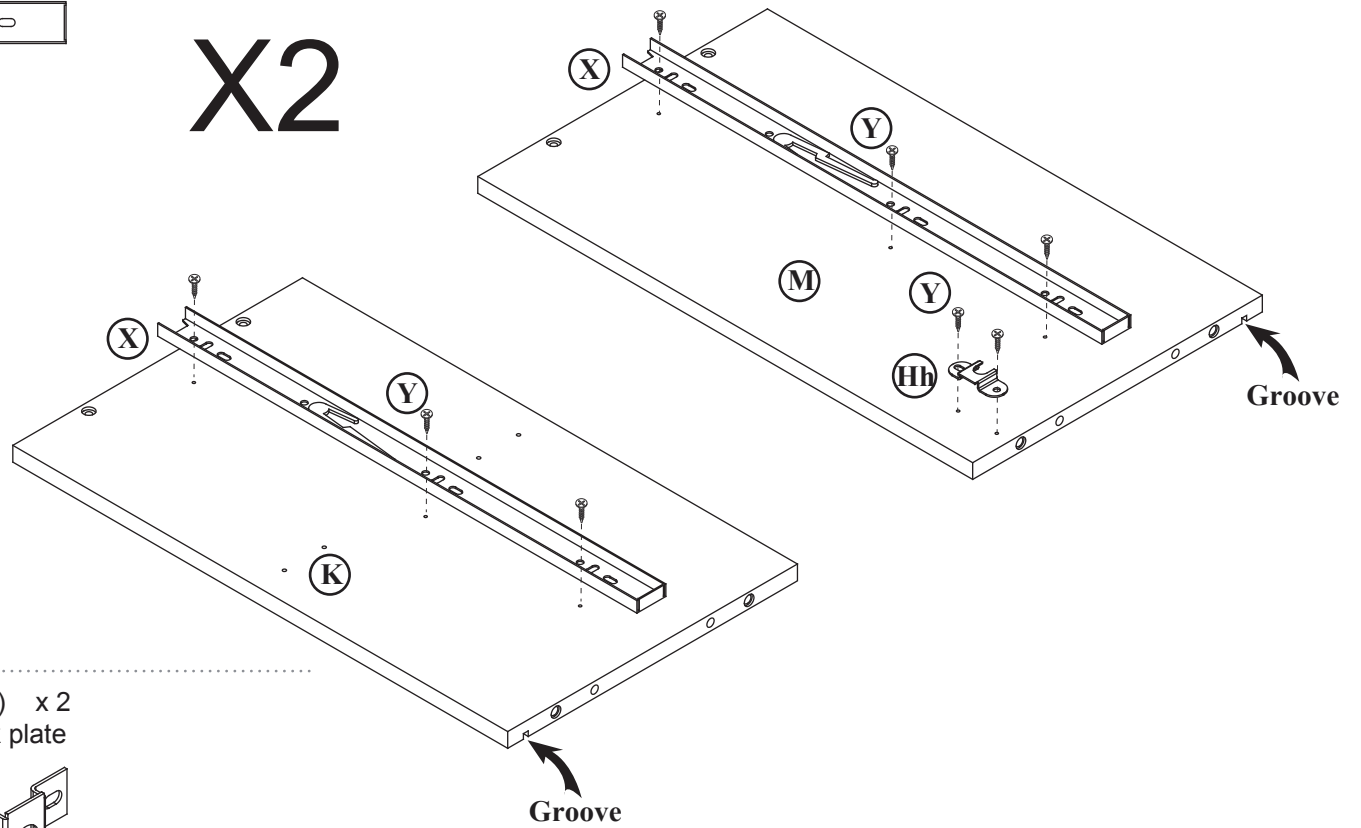


Diagram C

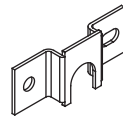
X2



(X) x 4
three ball bearing slide

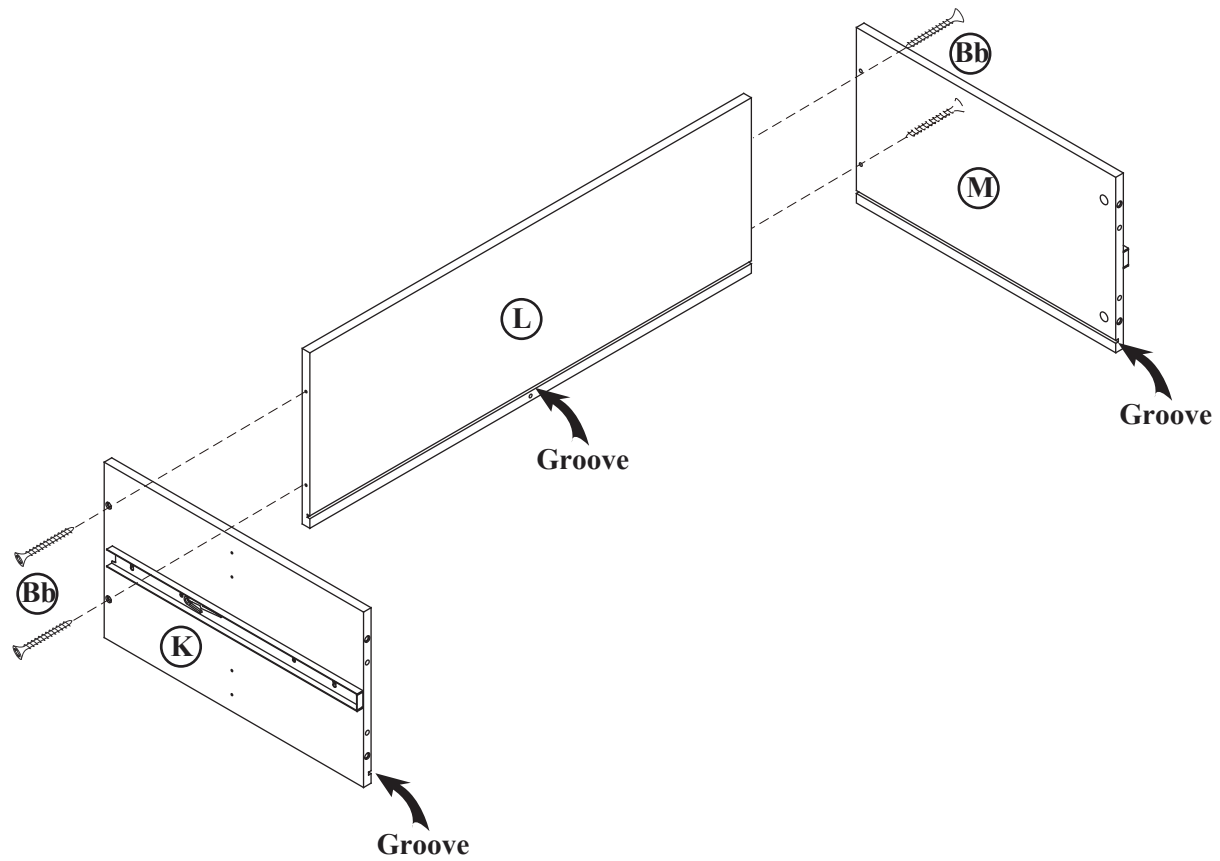
(Y) x 16
1/2" flat-head screw

(Hh) x 2
lock plate



1. Attach drawer slides to drawer left (K) and drawer right (M) using screws (Y) using the holes noted in diagram C.
2. Attach lock plate (Hh) to drawer right (M) as shown.
3. Repeat process for remaining left and right drawer sides.

step 9.

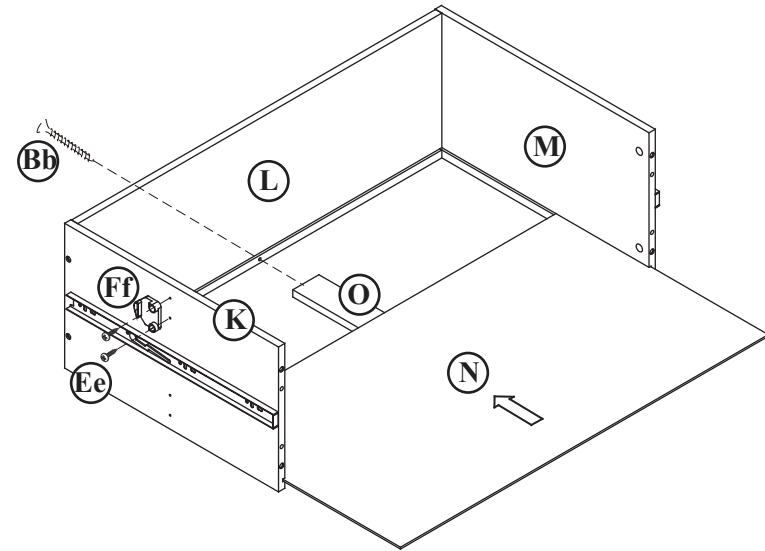
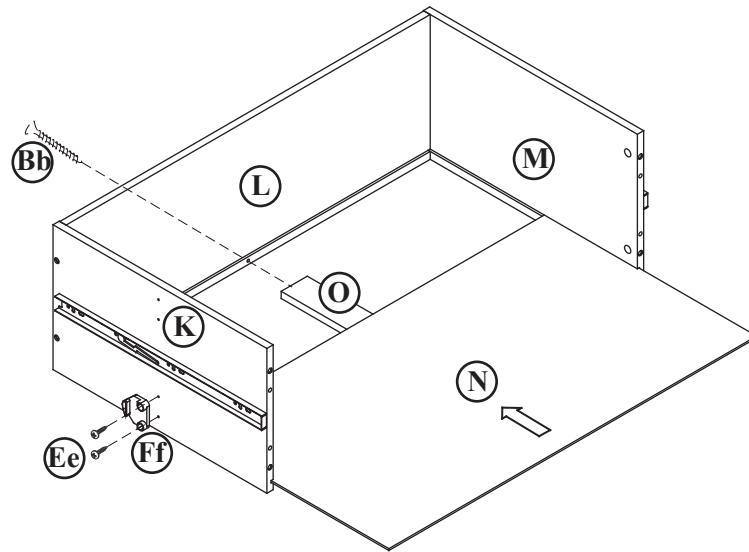


(Bb) x 8
1 3/8" flat-head screw



1. Attach parts K and M to drawer back (L) using screws (Bb).

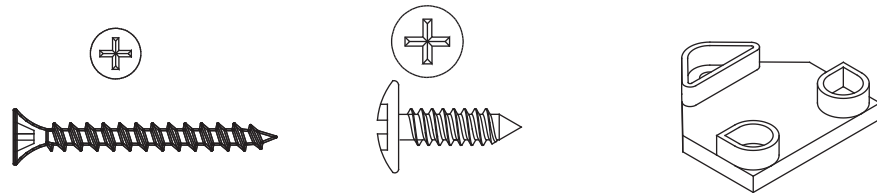
step 10.



(Bb) x 2
1 3/8" flat-head screw

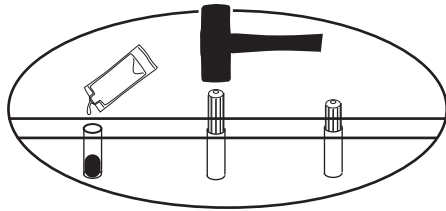
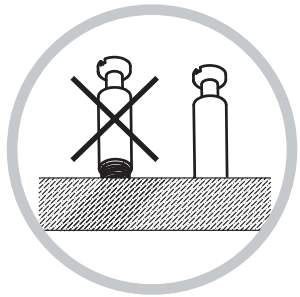
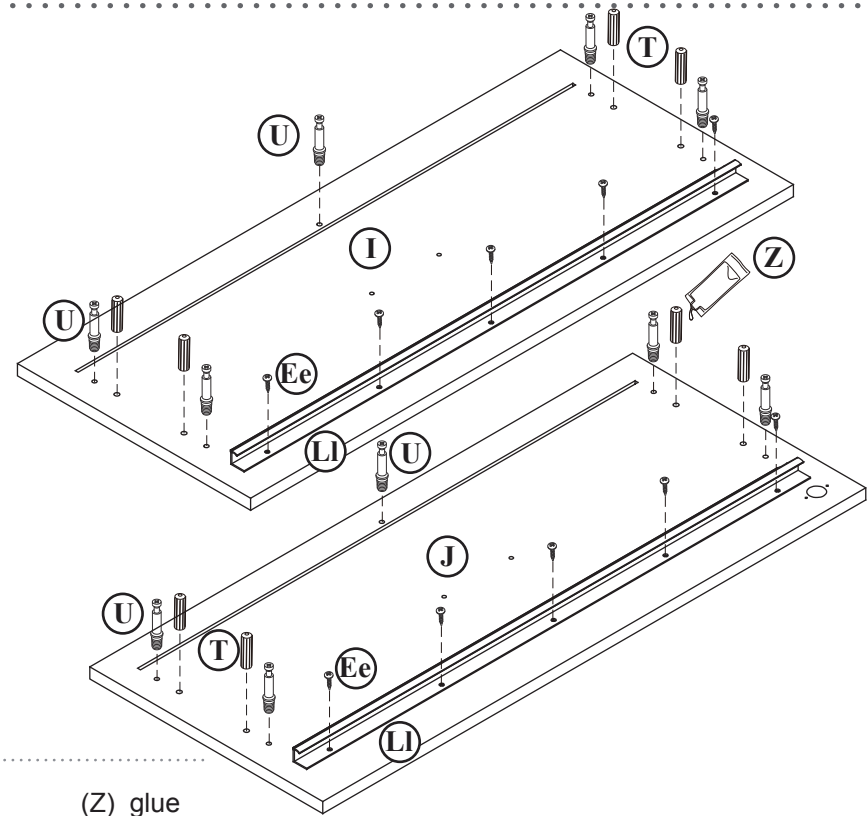
(Ee) x 4
9/16" round-head screw

(Ff) x 2
plastic anti-tip hardware

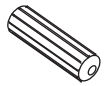


1. Attach drawer support rail (O) to drawer back (L) using screw (Bb).
 2. Slide drawer bottom (N) into grooves.
 3. Attach plastic anti tip hardware (Ff) to drawer front (K) using screw (Ee).
- * Note, part (Ff) goes below the slide on one drawer and above the slide on the other drawer.

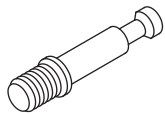
step 11.



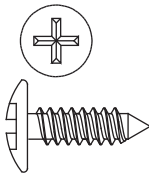
(T) x 8
1 1/4"x 1/4" dia wood
dowel with ridges



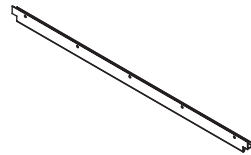
(U) x 10
small cam bolt



(Ee) x 10
9/16 " round-head screw



(Ll) x 2
plastic file hanger

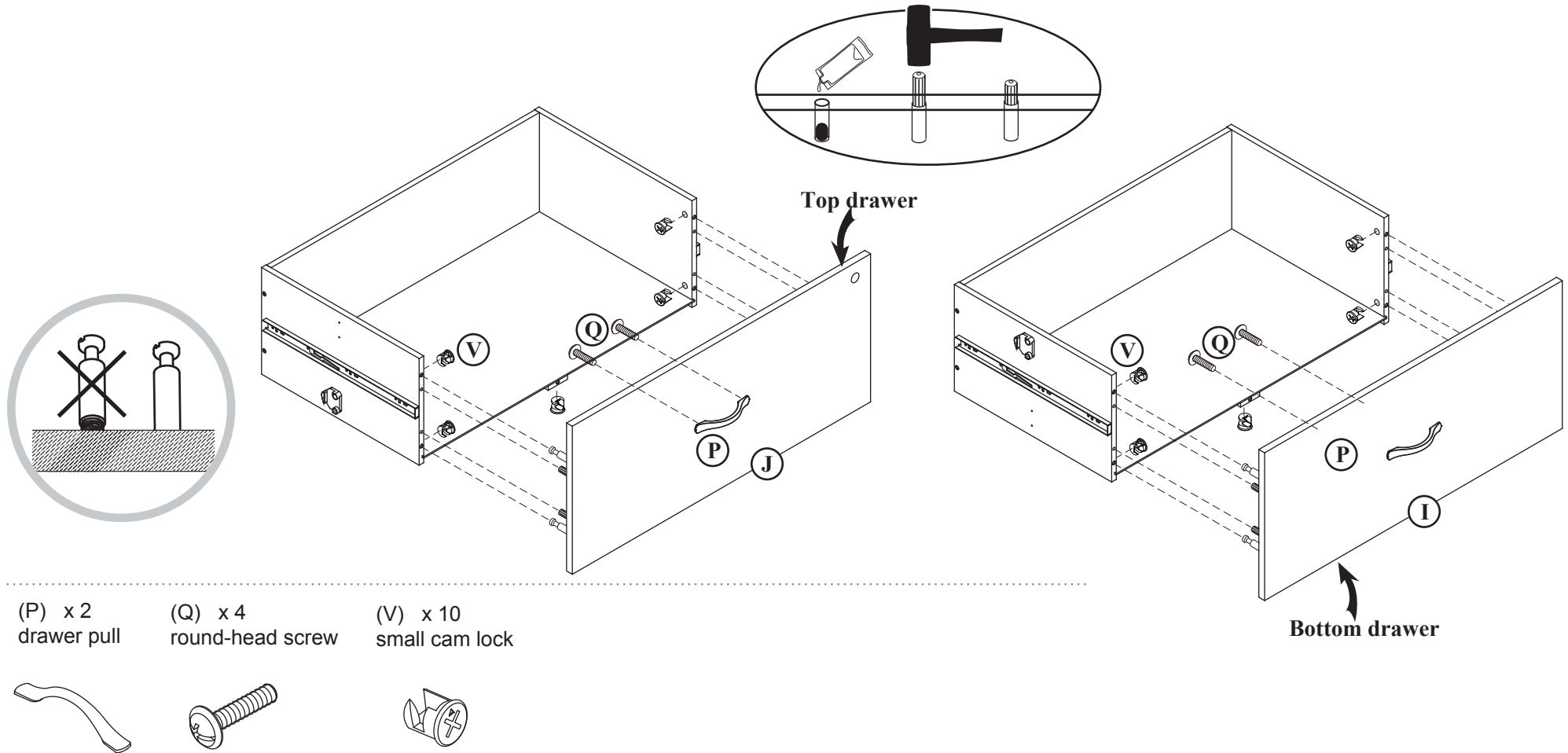


(Z) glue



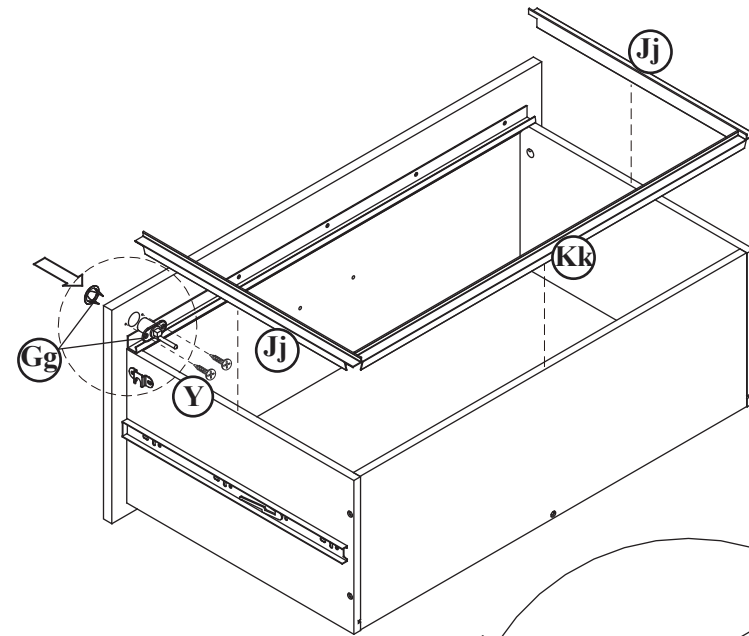
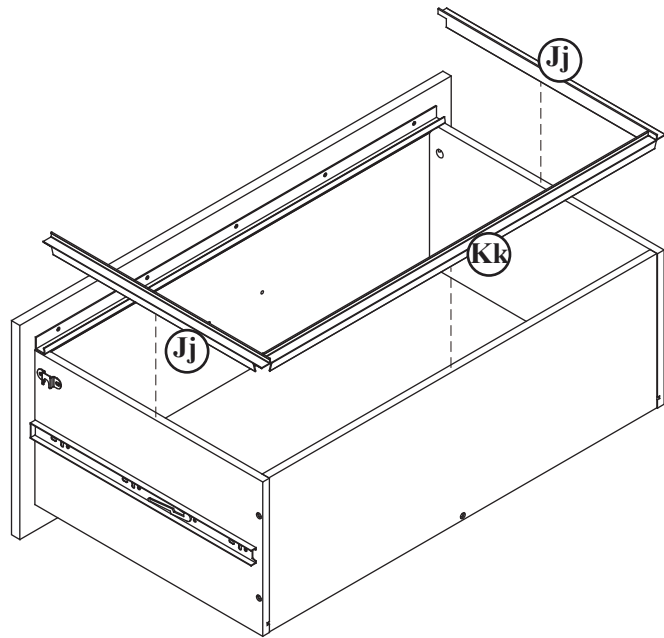
1. Install glue and small dowels (T) to drawer fronts (I) and (J).
2. Attach plastic file hanger (Ll) to drawer front.
3. Install small cam bolts (U) to drawer fronts (I) and (J).

step 12.



1. Attach drawer pull (P) to front with screw (Q).
2. Install small cam lock (U) into drawer sides.
3. Attach top drawer front (J) to drawer assembly with plastic anti tip hardware below the slide.
4. Carefully tighten all 5 small cam locks.
5. Attach bottom drawer front (I) to drawer assembly with plastic anti tip hardware above the slide.
6. Carefully tighten all 5 small cam locks.

step 13.



(Y) x 2
1/2" flat-head screw

(Gg) x 1
lock

(Jj) x 4
plastic file hanger

(Kk) x 2
plastic file hanger

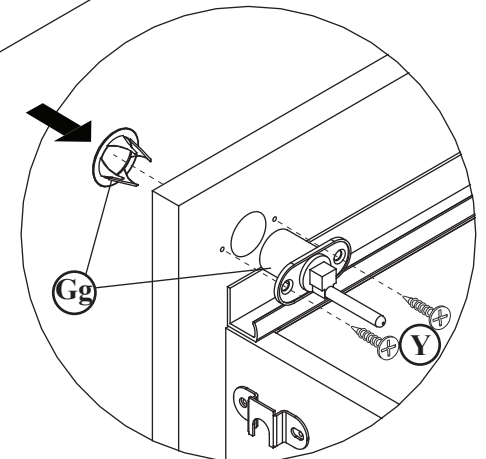
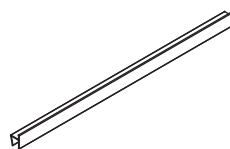
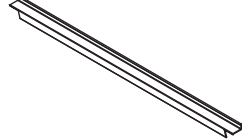
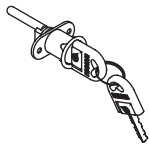
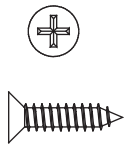
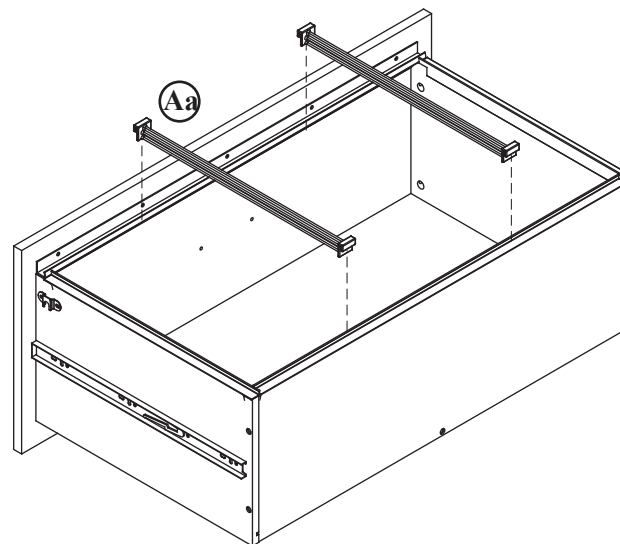
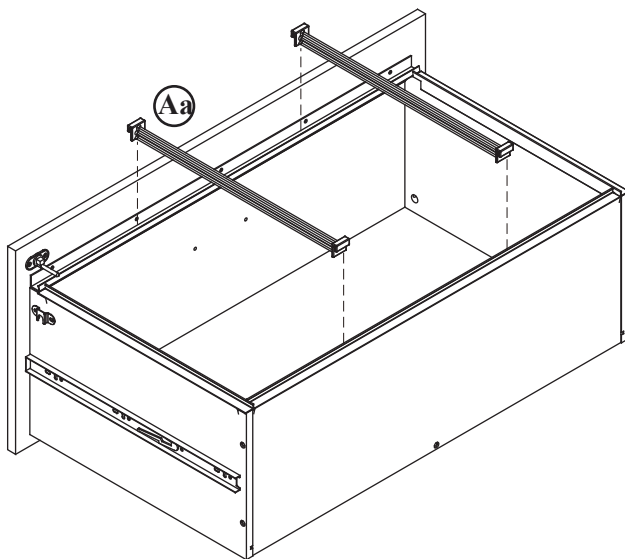


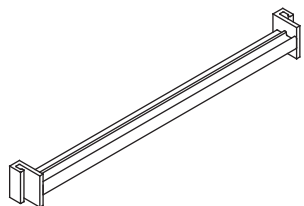
Diagram D

1. Remove washer from lock (Gg) and attach with screws (Y) per diagram D.
2. Install plastic file hanger (Jj) and (Kk) as shown.

step 14.



(Aa) x 4
plastic file hanger



1. Install plastic file hanger (Mm) as shown.

step 15.

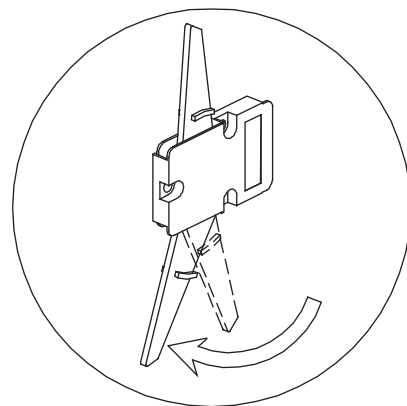
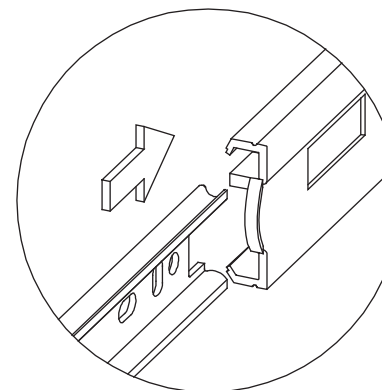
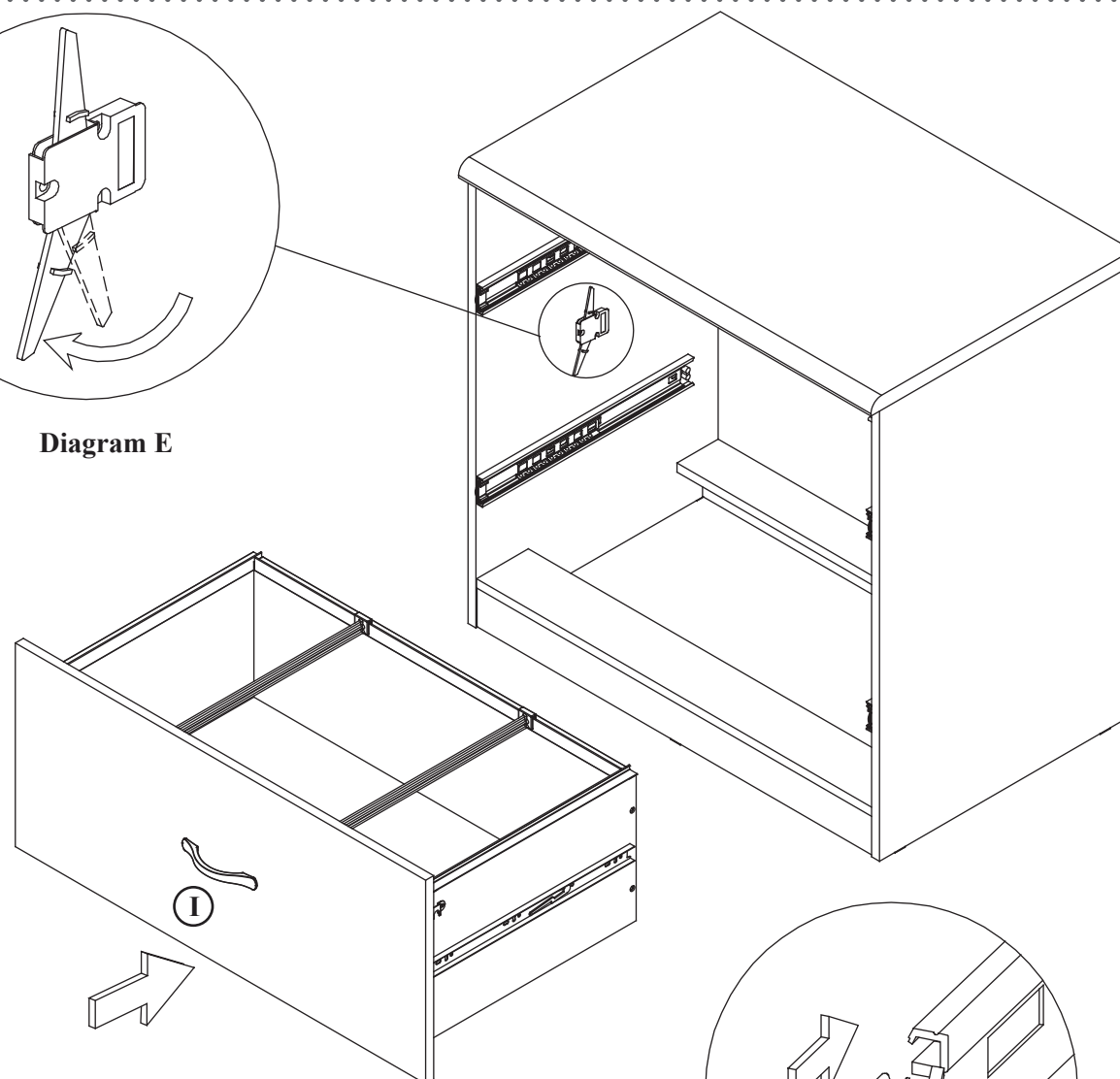


Diagram E



1. Swing bottom tab of anti tip hardware (Dd) to the front as shown in diagram E.
2. Slide the bottom drawer into the corresponding slides on the cabinet.

step 16.

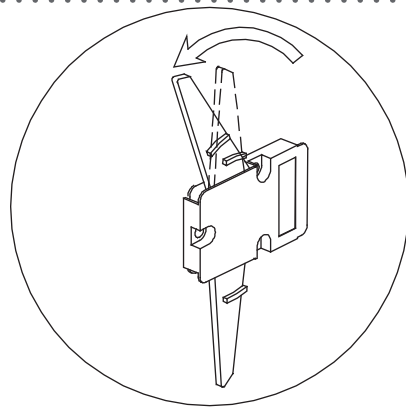
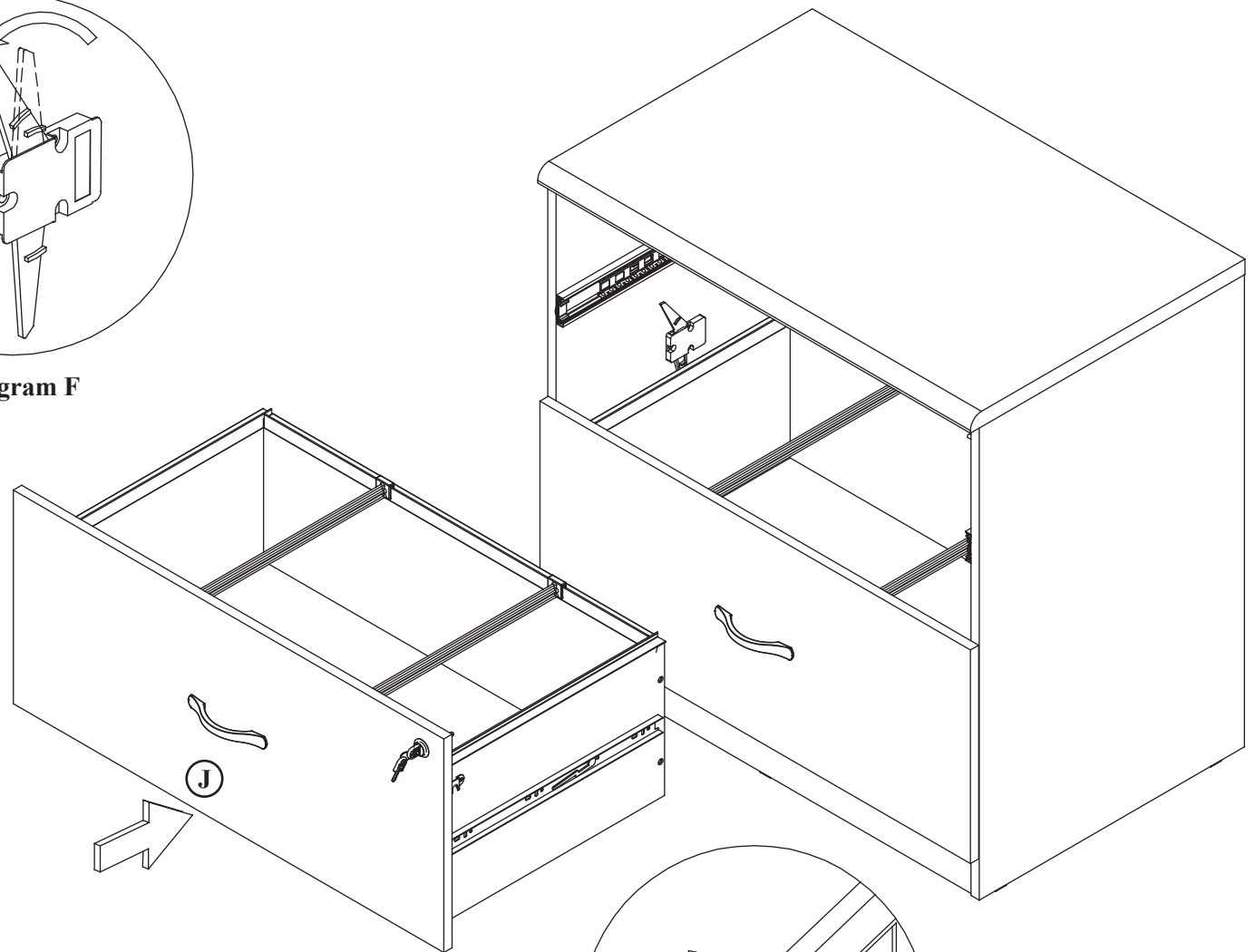


Diagram F



1. Swing the tab of anti tip hardware (Dd) to the front as shown in diagram F.
2. Slide the top drawer into the corresponding slides on the cabinet.

