

Keep this instruction manual for future use.



Division of Shamrock Industries, Inc.  
7001 Wooster Pike  
Medina, OH 44256  
1-877-716-2757 (U.S. Only)  
or 1-330-722-5033

 **Foundations<sup>®</sup>**

**Duo<sup>™</sup> Stroller**

**Double Tandem Stroller**

***ASSEMBLY & USE INSTRUCTIONS***

For use with children  
whose:

**Weight is:**

40 lbs. (18.1 kg)  
or less.

**Height is:**

40 inches (102 cm)  
or less.



Read all instructions *BEFORE* assembly and *USE* of product.

**KEEP INSTRUCTIONS FOR FUTURE USE.**

## **WARNING**

Failure to follow these warnings and assembly instructions could result in serious injury or death.

### **Avoid Serious Injury To Children From Falling Or Sliding Out:**

- **ALWAYS** use a harness to restrain each child.
- Snugly adjust harness around each child.
- **NEVER** leave children unattended, even when sleeping. Always keep children in view.
- **DO NOT** allow children to climb on stroller or stand in seat.

### **Avoid Serious Injury To Children:**

- **DO NOT** allow children to sit or stand in storage basket.
- **DO NOT** place any child weighing more than 40 lbs. (18.1 kg) or taller than 40 inches (102 cm) in this stroller.
- Use caution when pushing stroller near traffic or in highly congested areas.
- **DO NOT** use stroller on stairs or escalators with children in it.
- **DO NOT** lift stroller by arm bar.

### **Avoid Loss Of Control Of Stroller:**

- **ALWAYS** use front wheel swivel locks when pushing stroller on uneven terrain.
- Use caution when pushing stroller on uneven terrain or hills.
- **ALWAYS** set parking brake when the stroller is stopped.
- **NEVER** leave stroller unattended on a hill or incline even when parking brake is set.

### **Avoid Injury From Stroller Tipping Over:**

- **DO NOT** allow children to climb into stroller unassisted, or to play or hang onto stroller.
- **DO NOT** overload stroller as it can become unstable.
- **DO NOT** carry more than 2 children, one per seat or place extra parcels or goods in or on the stroller.
- **DO NOT** add package carrying accessories or hang items from stroller
- **DO NOT** place more than 15 lbs. (6.7kg) in storage basket.
- **ALWAYS** distribute weight as evenly as possible in each seat of the stroller.

### **Avoid Pinch Injury:**

- Keep fingers clear of hinged joints when folding and unfolding stroller.
- When making adjustments, always ensure all children's body parts are clear of any moving parts.

## **Assembly Instructions**

- *Adult assembly required. No tools required.*
- Read all instructions before ASSEMBLY and USE of Stroller.
- Unpack carton, remove packing materials, including polybag. Identify and check all parts. If parts are missing or damaged, call Foundations® Consumer Services at 1-877-716-2757 (U.S. Only) or 1-330-722-5033.

## **WARNING**

- **Plastic bags can cause suffocation. Keep plastic bag away from children. Remove and discard plastic bag.**

## **Assembly Assistance**

Foundations® strives for the highest quality in our products but occasionally a missing part or problem can occur during assembly.

If any parts are missing or broken or you need assistance with assembly, **DO NOT** return the product to your dealer. Call Foundations® for assistance at 1-877-716-2757 (U.S. Only) or 1-330-722-5033 (Monday through Friday, 9:00 a.m.– 4:00 p.m. Eastern Time). Please have the Stroller model number and manufacture date located on the inside surface of left arm rest near rear seat back available when you call or write us at: Foundations®, 7001 Wooster Pike, Medina, OH 44256.

## Duo™ Stroller Parts

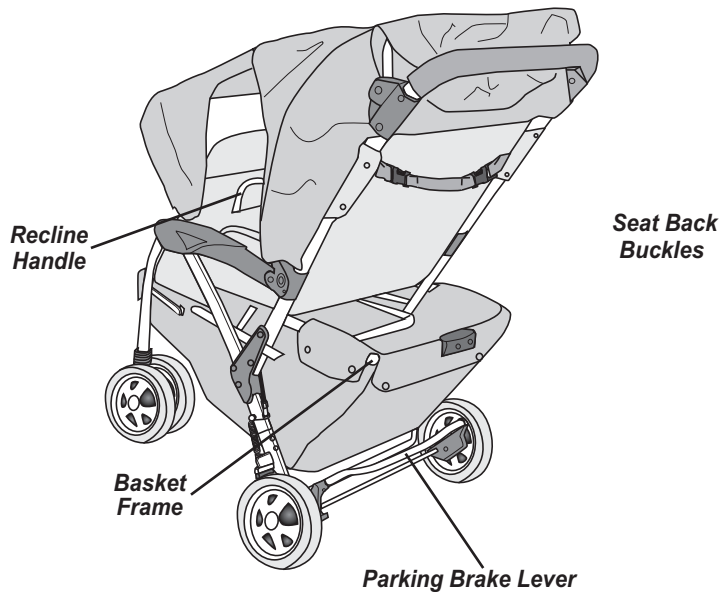
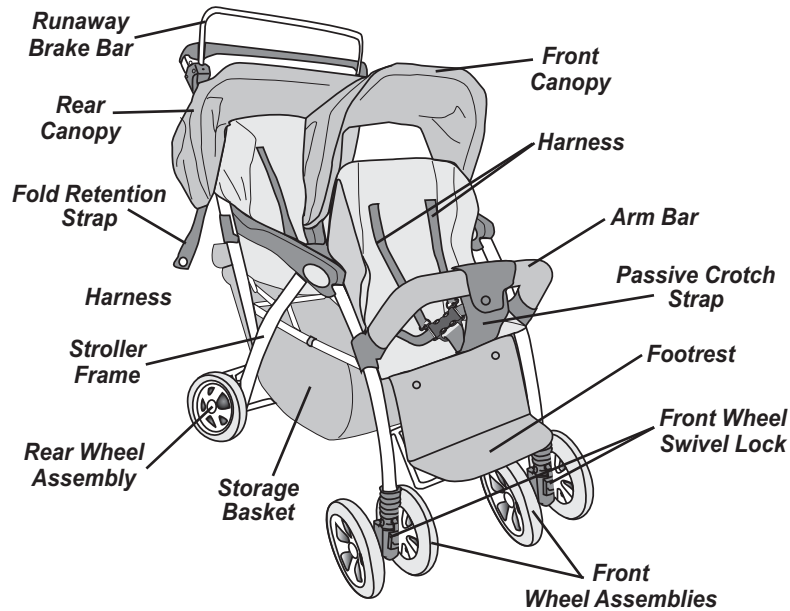

## Parts List

### PARTS LIST

Part Description	Quantity
A. Stroller Frame	1
B. Rear Wheel Assembly	1
C. Front Wheel Assembly	2
D. Arm Bar	1
E. Front Canopy	1
F. Basket Tube	1

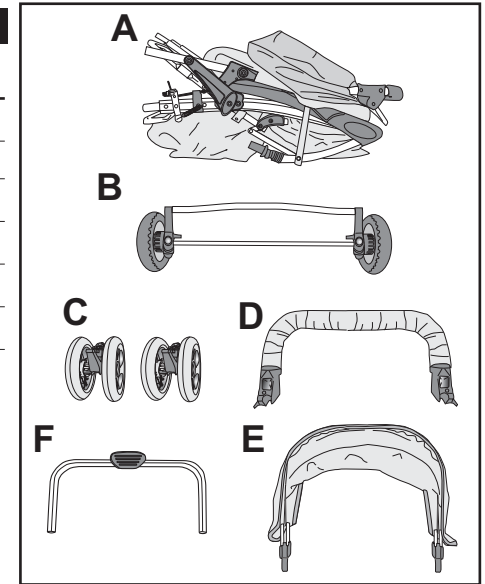

## STEP 1 - Basket Assembly

1. Place folded stroller down on the floor with the footrest facing down.
2. Line up open ends of **Rear Basket Tube** ① with ends of **Basket Tube** ② and slide onto **Rear Basket Tube** (Fig. 1).
3. Depress **Metal Spring Buttons** on both sides of the **Basket Tube** and slide **Rear Basket Tube** in until metal spring buttons snap through the holes on the **Rear Basket Tube** (Fig. 2).
4. Pull out on rear basket tube to check that snaps are locked in place.
5. Fold fabric sides over **Basket Tube** and snap in place (Fig. 3).

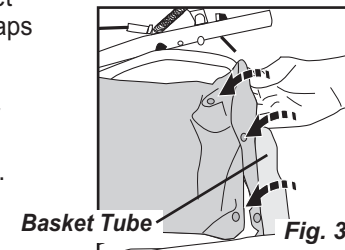
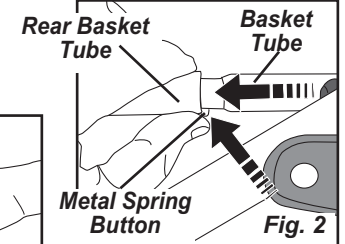
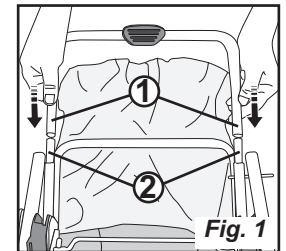

## STEP 2 - Rear Wheel Assembly

1. Turn stroller over on its back so that the footrest is facing up.
2. With parking brake lever facing down and openings in **Rear Wheel Assembly Sleeves** up, align and slide **Rear Wheel Assembly Sleeves** onto both rear leg tubes (**Fig. 1**).
3. After **Rear Wheel Assembly Sleeves** are started onto the rear leg tubes, move parking brake lever down into the locked position.
4. Slide **Rear Wheel Assembly Sleeves** up rear legs until spring buttons snap into hole in **Rear Wheel Assembly Sleeves**.

Pull out on **Rear Wheel Axle** to be sure **Rear Wheel Assemblies** are securely snapped to each rear leg.

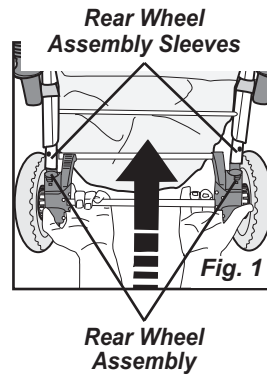

## STEP 3 - Front Wheel Assembly

1. Position front wheel assembly with large opening and swivel lock toward front leg sleeve.
2. Slide **Front Wheel Assembly** onto front leg sleeve until it snaps in place (**Fig. 1**).  
Pull out on **Front Wheel Assembly** to be sure it is securely snapped to the front leg.
3. Repeat for other **Front Wheel Assembly**.

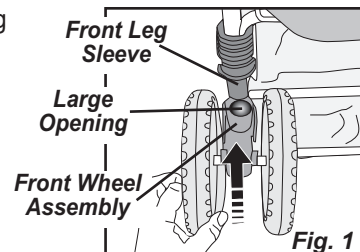

## STEP 4 - Arm Bar Assembly

1. Unfold stroller (see Unfolding Stroller section).
2. Assemble Arm Bar (see Arm Bar Operation section).

## STEP 5 - Front Canopy Assembly

1. Position front canopy with taller tube toward front of stroller.
2. Push end of **Canopy Frame** into canopy slot located on inside of outer armrest behind front seat (**Fig. 1**).
3. Repeat for opposite side of Canopy Frame.

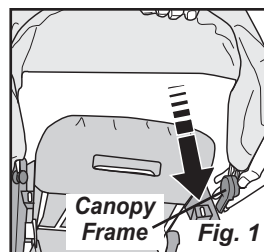

## STEP 6 - Securing Rear Canopy Sides

1. Place flap over side of handle (**Fig. 1**).

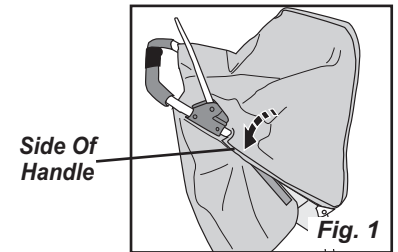

2. Press top and bottom flaps together to secure hook and loop fabric fastener (**Fig. 2**).

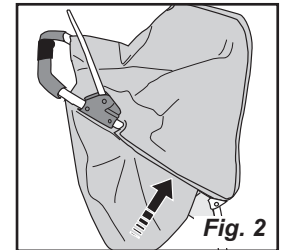

Repeat steps 1 through 2 for opposite side of canopy.

## Unfolding Stroller

1. To unfold stroller:

Check to be sure parking brake is in the locked position before unfolding stroller.

- A. With folded stroller standing up on wheels, locate **Fold Retention Strap**. Press stroller frame together and pull **Fold Retention Strap** off **Pin** on stroller frame (**Fig. 1**).
- B. Standing at stroller handle, place your toes under **Rear Basket Frame** and lift up on basket with your toes and pull handle up and back until handle locks in position (**Fig. 2**).
- C. Check that stroller is locked in the open position.
  - Lift up on handle.
  - Handle should maintain it's position and be rigid, it should not flex upward on either side.

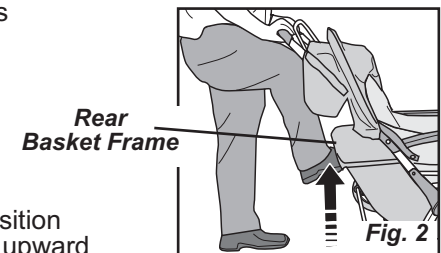
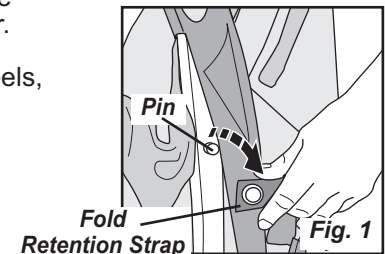

## Folding Stroller

### 1. To fold stroller:

- A. Push parking brake lever down to lock brakes.
- B. Place all seat backs in upright position.
- C. Squeeze fold lock slide on right side to unlock and slide red **Fold Lock Slides** on both sides of stroller handle toward handle grip (**Fig. 1**).
- D. Push handle forward to fold stroller.

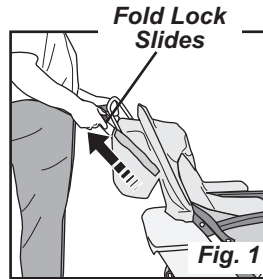

- E. Press folded stroller together and secure with **Fold Retention Strap** by placing **Fold Retention Strap** over **Pin** on stroller frame (**Fig. 2**).

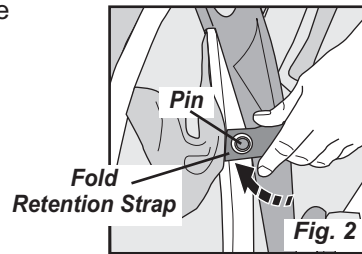

## Stroller Operation & Use

### Securing Children:

# ! WARNING !

### Avoid Serious Injury To Children From Falling Or Sliding Out:

- **ALWAYS** use a harness to restrain each child.
- **Snugly** adjust harness around each child.
- **NEVER** leave children unattended, even when sleeping. **Always** keep children in view.
- **DO NOT** allow children to climb on stroller or stand in seat.

1. With harness unbuckled, place child in seat.
2. Secure child with harness by placing **Shoulder and Waist Belts** over shoulders and over thighs. Snap buckle tongues into crotch strap buckle (**Fig. 1**).
3. Snugly adjust each strap by pulling on the free end of the strap and moving slide adjuster along strap (**Fig. 2**).

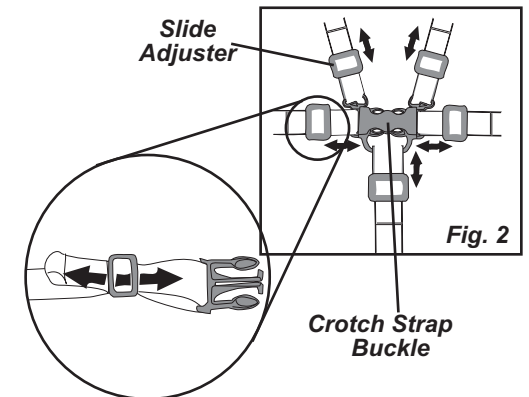
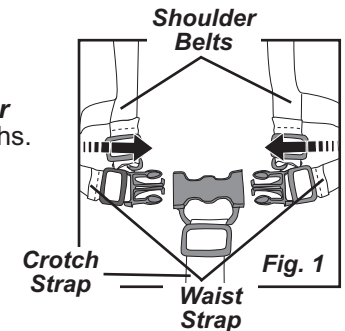

## Stroller Operation & Use (continued)

### Seat Back Recline:

**NOTE:** All seat backs must be in the upright position when folding stroller.

#### Front seat back:

##### To lower seat back:

1. Pull seat back **Recline Handle** up (**Fig. 1**).
2. Lower seat back to recline position and release seat back recline handle.

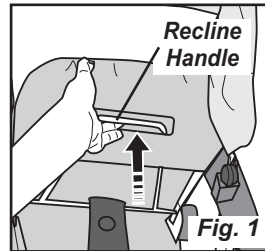

##### To raise seat back:

1. Pull seat back recline handle up.
2. Push seat back up and forward to upright position and release seat back recline handle.
3. Check that seat back is locked.

#### Rear seat back:

##### To lower seat back:

1. While holding seat back up, release both **Seat Back Buckles** (**Fig. 2**).
2. Lower seat back into reclined position.

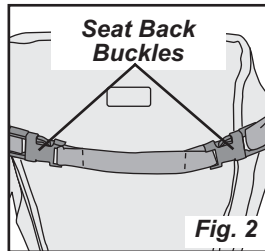

##### To raise seat back:

1. Push seat back up and forward to upright position and fasten both **Seat Back Buckles** (**Fig. 2**).

### Front Canopy Operation:

##### To remove front canopy:

1. Press retainer tab in and lift canopy frame up on one side of stroller (**Fig. 1**).
2. Repeat step 1 for other side of stroller.

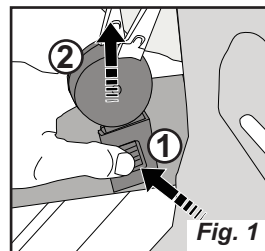

##### To attach front canopy:

1. Push end of **Canopy Frame** into slot on inside of armrest (**Fig. 2**).
2. Repeat for opposite side of Canopy Frame.

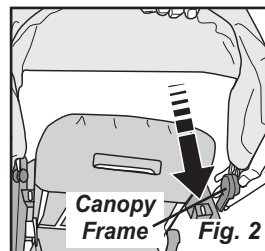

## Stroller Operation & Use (continued)

### Front Wheel Swivel Lock Operation:

#### To lock front wheel swivel:

1. Rotate front wheel assembly until it is straight back and swivel lock is aligned with swivel lock track (**Fig. 1**).
2. Push swivel lock up over swivel lock track until it snaps into place.
3. Check that front swivel is securely locked by pushing side to side on front wheel assembly.
4. Repeat steps 1 through 3 for the other front wheel assembly.

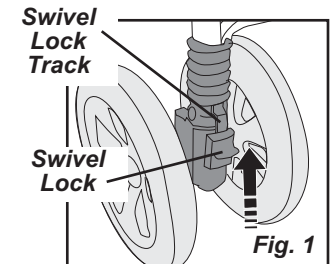

#### To unlock front wheel swivel:

1. Push swivel lock down until it is free of the swivel lock track (**Fig. 2**).
2. Repeat step 1 for the other front wheel assembly.

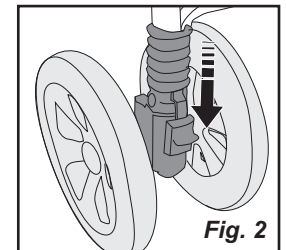

### Parking Brake Operation:

#### To lock parking brake:

1. Press down on parking brake lock bar on the rear wheel assembly (**Fig. 1**).
2. Check that wheels are locked.

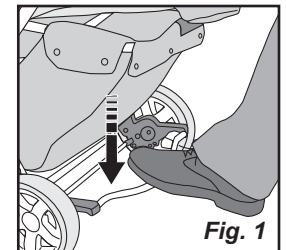

#### To unlock parking brake:

1. Lift parking brake lock bar up (**Fig. 2**).

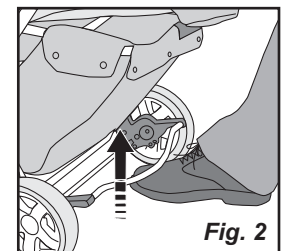

## Stroller Operation & Use (continued)

### Runaway Brake Operation:

To release runaway brake:

1. Pull runaway brake bar back and hold runaway brake bar against stroller handle while pushing stroller (**Fig. 3**).

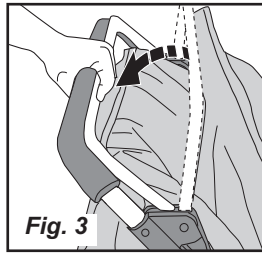

To apply runaway brake:

1. Release runaway brake bar (**Fig. 4**).

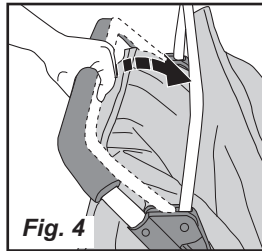

## Stroller Operation & Use (continued)

### Arm Bar Operation:

To remove arm bar:

1. Unfasten snap on front passive crotch strap.
2. Pull arm bar clamp out away from stroller to unlock arm bar from stroller frame (**Fig. 1**).
3. Push down and pull out on arm bar to remove it from stroller frame.

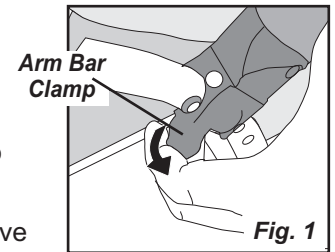

To attach arm bar:

1. Unfold stroller (see Folding and Unfolding Stroller section).
2. With Foundations® logo up, position **Arm Bar Assembly** onto front leg tubes between arm bar stops and snap onto front leg on both sides (**Fig. 1**).
3. Lock Arm Bar to stroller frame by pushing **Arm Bar Clamp** in toward stroller (**Fig. 2**).
4. Repeat step 3 for opposite end of Arm Bar.
5. Place **Passive Crotch Strap** in center of Arm Bar and secure snap (**Fig. 3**).

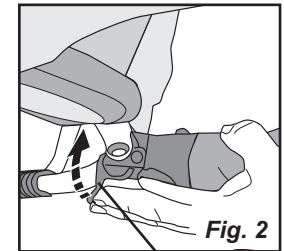
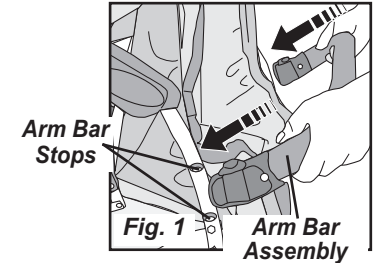

Arm Bar Clamp

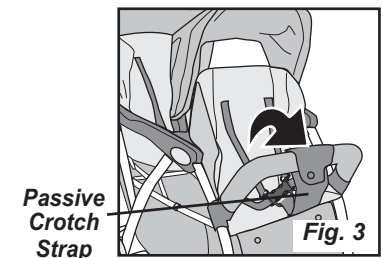

## Stroller Maintenance And Adjustments

### Runaway Brake Operation And Adjustment

*Runaway brake should be periodically checked for proper operation.*

To check for proper operation of hand brake:

**NOTE:** DO NOT check for proper operation of runaway brake while any children are in stroller.

- Release the brake and push the stroller at a walking pace on a flat level surface.
- While walking, release the stroller handle and hand brake bar.
- The stroller should stop almost immediately without turning, if it does not the runaway brake **MUST** be adjusted. To adjust the runaway brake follow the steps below:

#### To adjust runaway brake:

1. Using an adjustable wrench, loosen the **Jam Nut** on the runaway brake cable adjustment bolt (**Fig. 5**).
2. Using an adjustable wrench, turn the runaway brake **Cable Adjustment Bolt** clockwise to tighten brake or counter-clockwise to loosen brake on that side.
3. While holding runaway brake cable adjustment bolt, use an adjustable wrench to tighten jam nut.
4. Repeat steps 1 through 3 on opposite side of stroller.

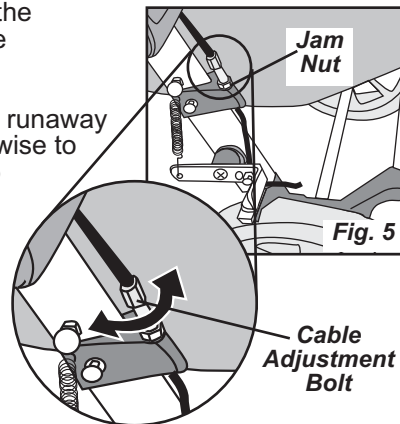

**NOTE:** It is important that both sides are adjusted equally so that the stroller will not turn when runaway brake is applied.

5. Recheck runaway brake for proper operation, see "To Check For Proper Operation Of Runaway Brake" section.
6. If the stroller still does not stop quickly or turns when runaway brake is applied, repeat steps 1 through 5.

**NOTE:** If problems persist call Foundations® for replacement parts or assistance.

## Stroller Maintenance And Adjustments (continued)

### Cleaning seat pad:

- Surface wash small spots with mild solution of soap and water. Do not use bleach.
- Rinse with water to remove soap solution.

### Cleaning stroller:

1. Surface wash stroller frame, plastic parts and fabric with mild solution of soap and water. Do not use bleach. Wipe surfaces with water to remove soap solution.
2. Wipe or air dry.

## One Year Limited Warranty

Foundations® warrants this product to be free from all defects in material and workmanship when used according to the manufacturer's instructions to the original owner for a period of one year from date of purchase. The warranty does not apply to damage caused by product alteration, normal wear and tear, misuse or abuse of the product. Keep your sales receipt as a record of the date of purchase. For replacement parts or warranty issues, please contact Foundations® as we are better able to serve you. **DO NOT** return the product to your retailer or distributor.

If you need assistance, call or write:  
Foundations®, 7001 Wooster Pike, Medina, OH 44256  
Telephone: 1-877-716-2757(U.S. Only) or 1-330-722-5033  
Fax: 1-330-722-5037