







Hardware List (included in GT247)



	2 PCS Keys For File Drawer Lock		4 PCS Machine Bolts(1-1/4")
	2 PCS Long(1-1/4")Flat Head wood Screws		4 PCS Wooden Dowel (ø8x25)
	8 PCS Short(1") Flat Head Wood Screws		
	4 PCS Long(1-1/4")Round Head wood Screws		

GT247T Parts List

E	DESK TOP	1 PC
---	----------	------

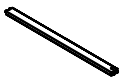
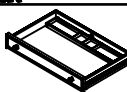

GT247B Parts List

A	PEDESTAL	1 PC	B	SIDE PANEL	1 PC	C	BACK PANEL	1 PC
								
D	CROSS BAR	1 PC	F	DROP FRONT CENTER DRAWER	1 PC			
								

Instructions:

1. Move the pedestal (A) and side panel (B) to the desired location.
2. Align the back panel (C) to pedestal (A) and side panel (B), insert and tighten (1-1/4") Machine Bolts (4PCS) and (1-1/4") Round Head Wood Screws (4PCS).
3. Connect the center cross bar (D) to the pedestal (A) and side panel (B), tighten with (1-1/4") flat head wood screws(2 PCS).
4. Insert two wood dowels (4pcs) in the pedestal (A) and side panel (B).

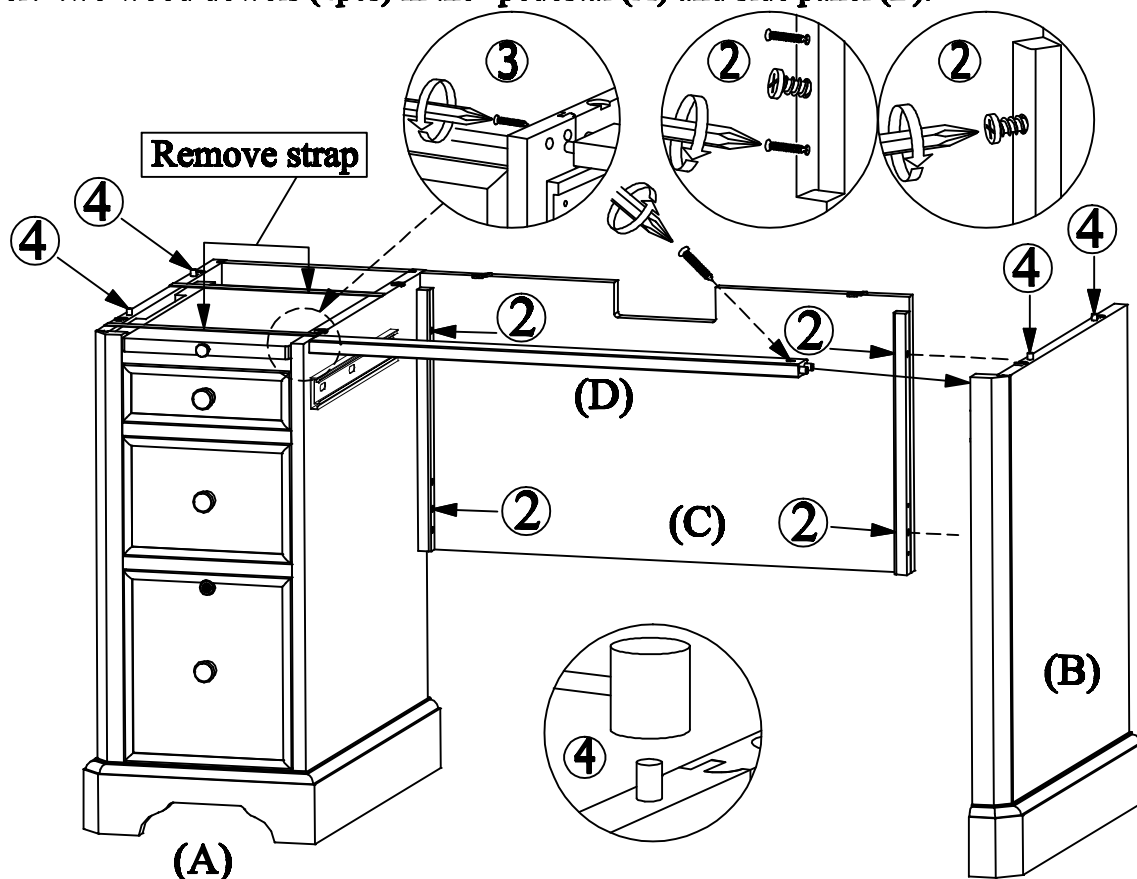

5. Loosen the screw to adjust metal figure 8 (8 PCS) of its direction of the panel .

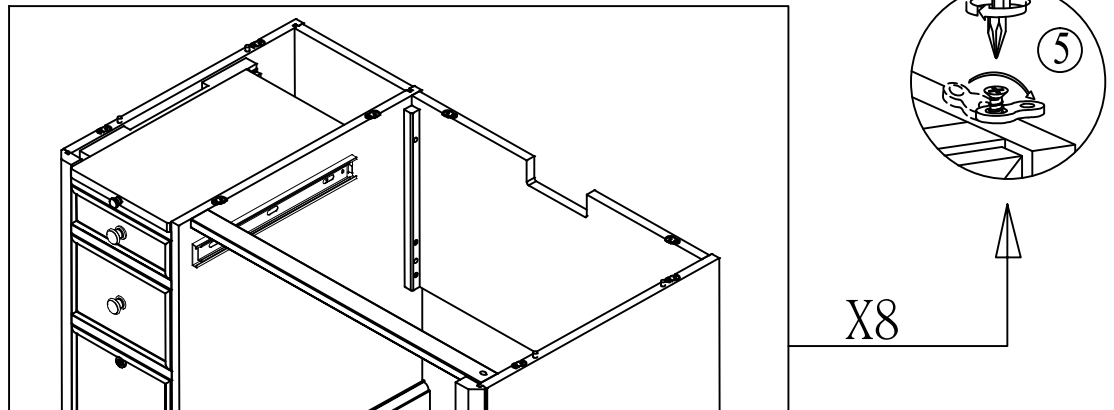

6. Place the desk top (E) on the bases face up and make sure the dowels are aligned properly.

7. Insert **Short (1") flat head wood screws (8 PCS)** through the metal figure 8 to connect desk top (E) and base.

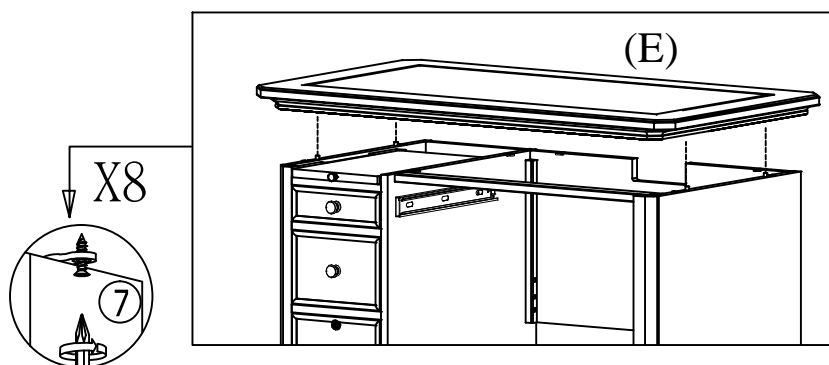

8. Insert the drop front center drawer (F) in place.

Important:

(Be sure to move the ball bearing retainer all the way to the front of the glide and carefully slide the rails into the glides and ball bearing retainer.)

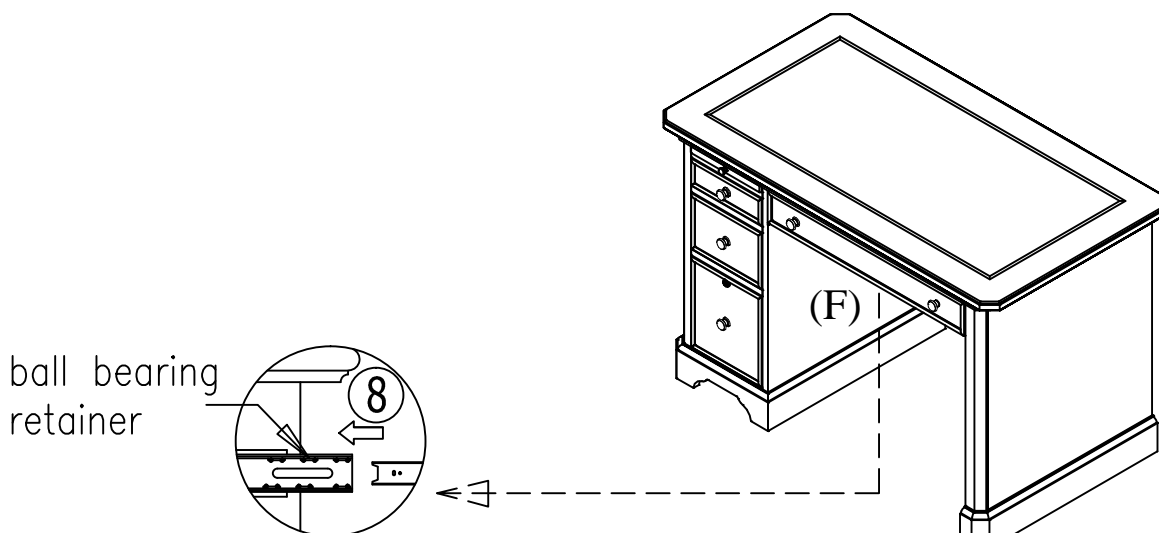

Assembly is now complete.