

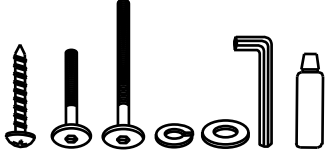

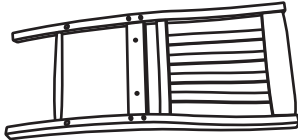



Assembly Instructions

DQT145224

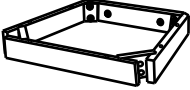
RAKE BACK BARSTOOL

PARTS LIST

PART NO	FIGURE	DESCRIPTION	Q'TY
DQT145224-01		Hardware Bag	1 Pce
DQT145224-02		Chair Back	1 Pce
DQT145224-03		Wood Seat	1 Pce
DQT145224-04		Seat Frame	1 Pce
DQT145224-05		Front Leg (Right)	1 Pce
DQT145224-06		Front Leg (Left)	1 Pce
DQT145224-07		Side Stretcher (Right / Left)	2 Pcs
DQT145224-10		Front Stretcher (Short)	1 Pce

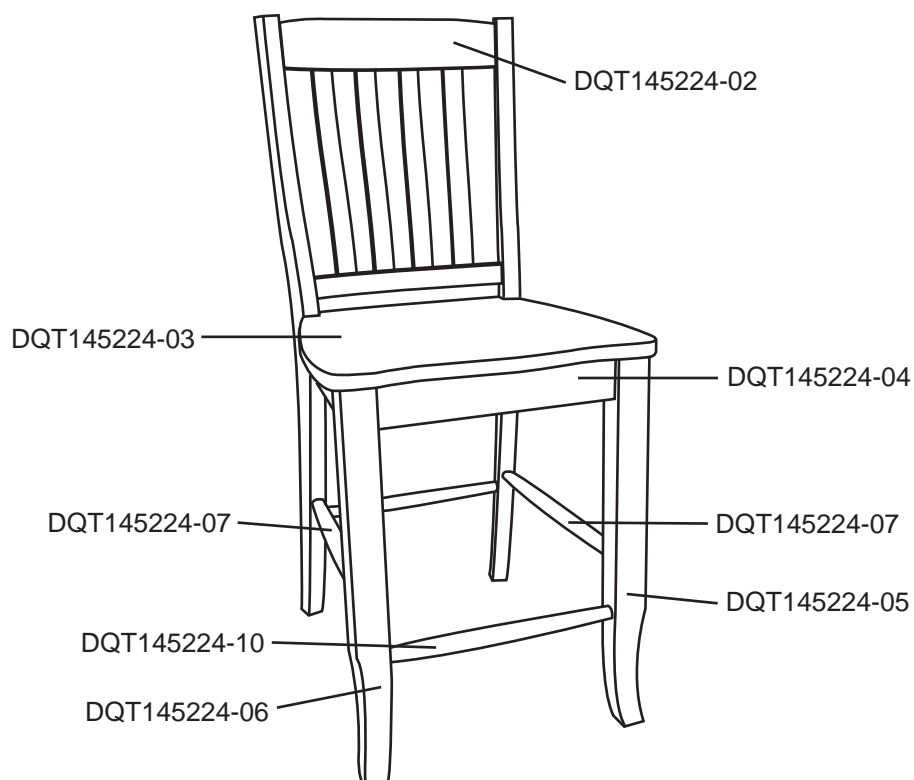







Assembly Instructions

DQT145224

RAKE BACK BARSTOOL

HARDWARE PARTS:

						
Pan Head Screw 6 pcs	(Short) JCBC Bolt 2 pcs	(Long) JCBC Bolt 8 pcs	Lock Washer 10 pcs	Flat Washer 10 pcs	Allen Key 1 pce	Glue 1 pce

ASSEMBLY:

1. Position the chair back on a soft surface such as a carpet. Place the box system assembly (Hardseat is pre-attached to the seat frame in assembly) on to the middle rail of the chair back with the dowel fully inserted into the pre-drilled hole.
 - 1.1. Insert **JCBC Bolt (Long)** through a **Lock Washer** and a **Flat Washer** into the pre-drilled holes on the apron frame at rear corners.
 - 1.2. Insert the **JCBC Bolt (Short)** through a **Lock Washer** and a **Flat Washer** into the pre-drilled holes on the apron frame at rear rail.
2. Apply **Glue** to all the pre-drilled holes before attaching all stretchers. Insert each side stretcher into pre-drilled holes on both of the rear legs, make sure that screw holes on the stretcher are facing down. Insert the front stretcher into the pre-drilled holes on the front legs. Place the assembled front legs to corner block of the frame, and insert side stretcher into the legs.
 - 2.1. Insert the **JCBC Bolt (Long)** through a **Lock Washer**, a **Flat Washer** and the pre-drilled holes of corner block into the pre-drilled holes on the front leg, tighten the **JCBC Bolt** with **Allen Key** provided. But do not fully tighten the bolts yet.
 - 2.2. Insert **Pan Head Screw** into front stretcher and side stretcher through the pre-drilled holes, tighten with screw driver. (Not Provided)

STEP 1

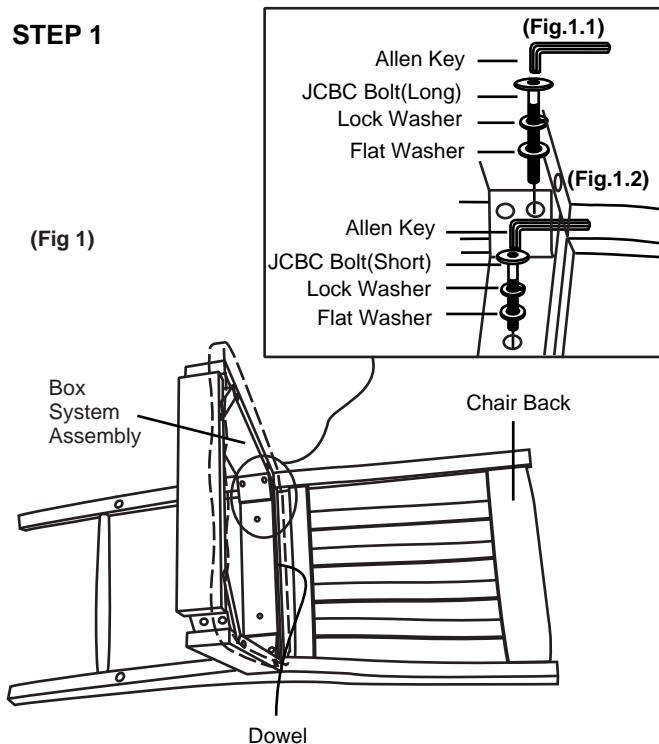

STEP 2

Apply Glue and insert stretcher with screw holes facing down.

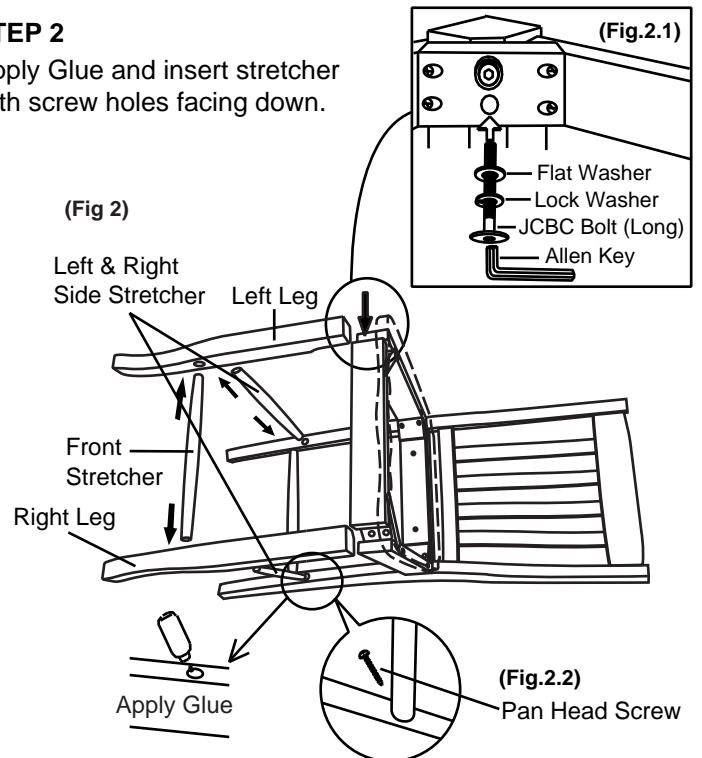

STEP 3

Turn the chair upright. Check its balance and tighten all screws and bolts to complete the assembly.

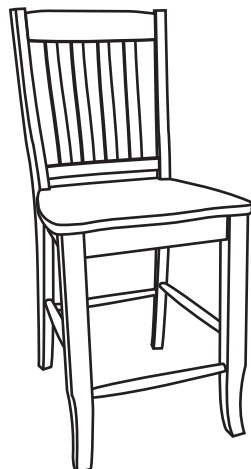

CARE INSTRUCTION

- ~ Be sure to use the same type of polish consistently. Your furniture will appear cloudy or streaky if oil based or wax based polishes are interchanged.
- ~ Spray your furniture surface evenly. Wipe in a circular motion with a soft clean cloth.