



All products are trademarks of Nostalgia Products Group, LLC.
Worldwide design & utility patented or patents pending.
© 2012 Nostalgia Products Group, LLC.

www.nostalgiaelectrics.com

(rev. 10/04/12)



KRS2100
SERIES

Kegorator™

Instruction Manual



Make everyday a party!
Visit www.nostalgielectrics.com for more fun products.

CONTENTS

IMPORTANT PRECAUTIONS	3
IMPORTANT SAFEGUARDS	3
INTRODUCTION	5
PARTS & ASSEMBLY	6
WASHERS	6
REGULATOR	8
INSTALLING THE CASTERS	9
INSTALLING THE GUARDRAIL	9
CO ₂ & TAP TOWER INSTALLATION	10
TAPPING THE BEER KEG	13
HOW TO OPERATE	13
HELPFUL TIPS	14
CLEANING & MAINTENANCE	15
RETURNS & WARRANTY	16

SAFETY

Your safety and the safety of others is very important.

We have provided many important safety messages in this manual and on your appliance. Always read and obey all safety messages.



This is the safety alert symbol.

This symbol alerts you to potential hazards that can kill or hurt you and others.

All safety messages will follow the safety alert symbol.

All safety messages will tell you what the potential hazard is, tell you how to reduce the chance of injury, and tell you what can happen if the instructions are not followed.

Appliance Specifications:

115V 60Hz 1.47A (max amps = 6A) UL Approved

IMPORTANT PRECAUTIONS

1. NEVER use an abrasive sponge, cloth or scouring pad on this appliance.
2. NEVER leave appliance unattended while in use.
3. Unplug unit from outlet when not in use and during cleaning.
4. DO NOT operate this appliance with a damaged cord or plug, or if the appliance ever malfunctions.
5. DO NOT clean any parts of this appliance in a dishwasher.
6. Keep out of reach of children.
7. This appliance is NOT A TOY.
8. Unsupervised young children and cognitively challenged individuals should never operate this appliance.
9. Young children should be supervised while in proximity of the appliance to ensure their safety.

SAVE THESE INSTRUCTIONS!

IMPORTANT SAFEGUARDS

Basic safety precautions should always be followed when using electrical appliances, including the following:

1. Use this appliance only for its intended purpose as described in this instruction manual.
2. This appliance must be properly assembled according to the assembly instructions in this manual before it is used. See the Parts & Assembly section for more details.
3. This appliance must be connected to a proper electrical outlet with the correct electrical supply.
4. Proper grounding must be ensured to reduce the risk of shock and/or fire. DO NOT cut or remove the grounding plug. If you do not have a three-prong outlet in the wall, have a certified electrician install the proper outlet.
5. Never unplug your appliance by pulling on the power cord. Always grasp the plug firmly and pull straight out from the outlet.
6. Immediately replace worn power cords, power outlets and loose plugs.
7. To reduce the risk of electric shock or fire, do not use extension cords or adapters to connect the unit to an electrical power source.
8. Unplug your appliance before cleaning or making any repairs.
9. We suggest that a certified technician perform the service if for any reason this product requires service.
10. This appliance should not be recessed or built into an enclosed cabinet. It is designed for freestanding assembly only.
11. Do not operate your appliance in the presence of explosive fumes.
12. Do not tamper with the controls.

13. Do not operate this appliance when parts are missing or broken.
14. Do not use this appliance for commercial use.
15. This appliance is designed for indoor use only and should not be used outdoors.
16. To reduce is the risk of injury, do not allow children to play in or on the appliance. Close supervision is necessary when the appliance is used near children.
17. The appliance door must be closed during operation. Do not leave the door open when children are near the dispenser.
18. DO NOT not attempt to operate this unit with a damaged cord or plug. DO NOT roll the KEGORATOR™ with loaded beer kegs onto carpet floor.
19. This appliance is not intended for use by young children or cognitively challenged individuals without supervision.
20. This appliance is NOT A TOY!
21. Young children should be supervised to ensure that they do not play with this appliance.



Before discarding your old appliance, remove the door from its hinges so that children may not easily become trapped inside.

CO₂ (Carbon Dioxide) Gas

1. CO₂ gas can be dangerous! CO₂ cylinders contain high-pressure compressed gas, which can be hazardous if not handled properly. Make sure you read and understand all the procedures for the CO₂ cylinders before installation.
2. Always connect the CO₂ cylinder to a regulator! Failure to do so may cause an explosion resulting in possible death or injury when the cylinder valve is opened.
3. Never connect the CO₂ cylinder directly to the beer keg.
4. Always follow the correct procedures when changing the CO₂ cylinder.
5. Never drop or throw a CO₂ cylinder.
6. Always keep CO₂ cylinders away from heat. Store extra cylinders in a cool place (preferably 70° F). Secure fasten with a chain in an upright position when storing.
7. **ALWAYS** ventilate and leave the area immediately if CO₂ leakage has occurred.
8. There are two safety devices in the pressure system in the form of a valve. One safety feature is on the CO₂ bottle. The second is on the regulator.
9. Never attempt to refill CO₂ cylinder yourself.

NOTE: If the refrigerator has been placed in a horizontal or tilted position for any period of time wait 8 hours before plugging the unit in.

INTRODUCTION

To ensure that your KEGORATOR™ works to the maximum efficiency for which it was designed, keep it in a location where there is proper air circulation and electrical outlets. Choose a location where the KEGORATOR™ will be away from heat and will not be exposed to direct sunlight.

- The KEGORATOR™ is designed for **indoor use only**. It should not be used outdoors.
- The KEGORATOR™ is designed to be freestanding and should not be placed in a built-in or recessed area.
- The KEGORATOR™ comes with a 2.5 lb. CO₂ bottle, which should be able to dispense four 15 gallon kegs of beer.
- KEGORATOR™ capacity: 4.6 cu. ft.
- KEGORATOR™ unit dimensions: L 20.25" x W 25.75" x H 48.50"
- The following dimensions are recommended for clearances around the KEGORATOR™:
 Sides ¾" (19 mm)
 Back 1" (25 mm)
- KEGORATOR™ unit weight: 77.6 lbs

Compatible Keg Types

The KEGORATOR™ can hold one Full Size Keg, or one Pony Keg, or two 5-Gallon Kegs. **DOES NOT** fit non-standard keg sizes.

NOTE: Keg Coupler fits D-Sankey Keg Valves. Attaching the Keg Coupler will add height to the Keg.

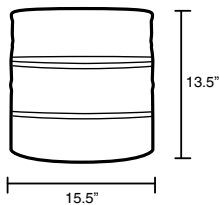

¼ Barrel Pony Size
(7-8 Gallons)

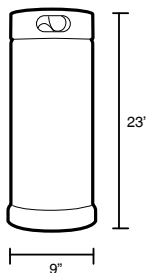

5 Gallon D System

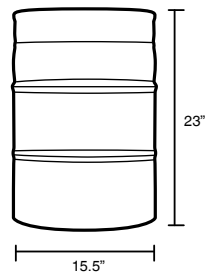

½ Barrel Full Size
(14-16 Gallons)

PARTS & ASSEMBLY

Read assembly instructions carefully before installing the KEGORATOR™. If still unsure whether the KEGORATOR™ has been properly installed after assembly is complete, it is recommended that you contact a qualified installer.

Allow the KEGORATOR™ to stand in an upright position for about 8 hours before turning on the power. Once the unit is laid on its side, the coolant in the refrigeration unit is shifted. The coolant in the refrigeration unit needs to stabilize before the power is turned on.

WASHERS

Most washers are already attached to the KEGORATOR™. Extra washers are included and are in a plastic bag. They are labeled below. Refer to parts diagram and corresponding numbers to see where the washers belong.



#1 Bottom of
Coupler (outside)
(38mm)



#1 Bottom of
Coupler (middle)
(22mm)



#1 Bottom
of Coupler (center)
(19mm)



#3 Coupler Washer
(18mm)



#4 CO₂ Rubber
Directional Washer



#18 CO₂ Tank Band



#19 CO₂ Line to
Regulator
(7mm)



#21 CO₂ Line
to Coupler (10mm)



#25 Beer Tap
Washer (22mm)

Parts

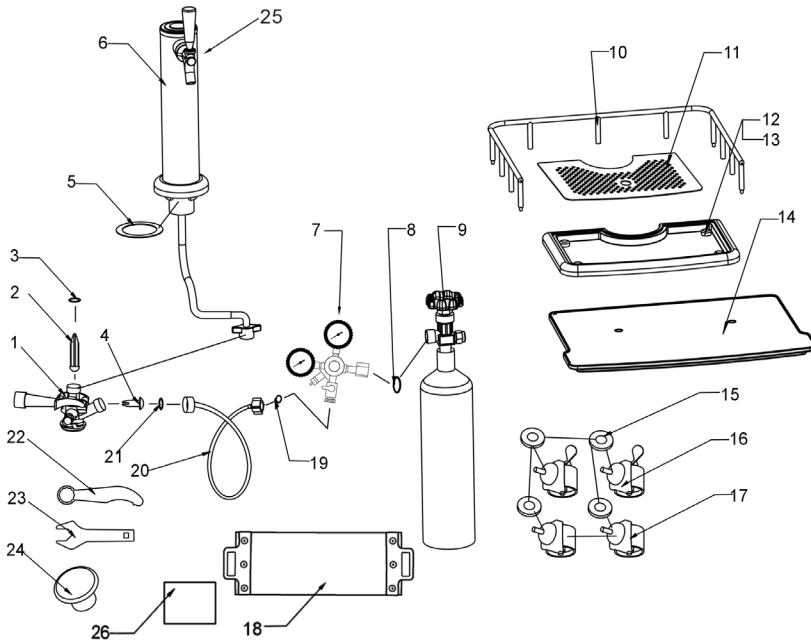

#1 Keg Coupler (Fits D-Sankey Keg Valves) Qty. 1	#2 Backflow Stopper Qty. 1	#3 Rubber Washer Qty. 1	#4 CO ₂ Rubber Directional Washer Qty. 1
#5 Beer Tower Washer Qty. 1	#6 Beer Tap/Hose Assembly Qty. 1	#7 CO ₂ Regulator Qty. 1	#8 High Pressure Washer, White Nylon Qty. 1
#9 CO ₂ Tank Valve Qty. 1	#10 Guard Rail Qty. 1	#11 Drip Tray Grate Qty. 1	#12 Drip Tray Pan Qty. 1
#13 Rubber Foot Qty. 4	#14 Keg Base Board Qty. 1	#15 Metal Washer Qty. 4	#16 Front Casters with Locking Mechanism Qty. 2
#17 Rear Casters Qty. 2	#18 CO ₂ Tank Band Qty. 1	#19 Air Hose Wing Nut Washer Qty. 1	#20 Air Hose Qty. 1
#21 Air Hose Connector Washer Qty. 1	#22 Beer Tap Wrench Qty. 1	#23 Regulator Plug Qty. 1	#24 Beer Tower Hole Qty. 1
#25 Beer Tapper & Handle Qty. 1	#26 Extra Washers & Parts		

REGULATOR

The Double Regulator works the CO₂ Tank and measures PSI (pounds per square inch), as well as the volume of the CO₂ gas in the Cylinder. Set Output Pressure Gauge between 8-12 PSI for a nice, frothy head.

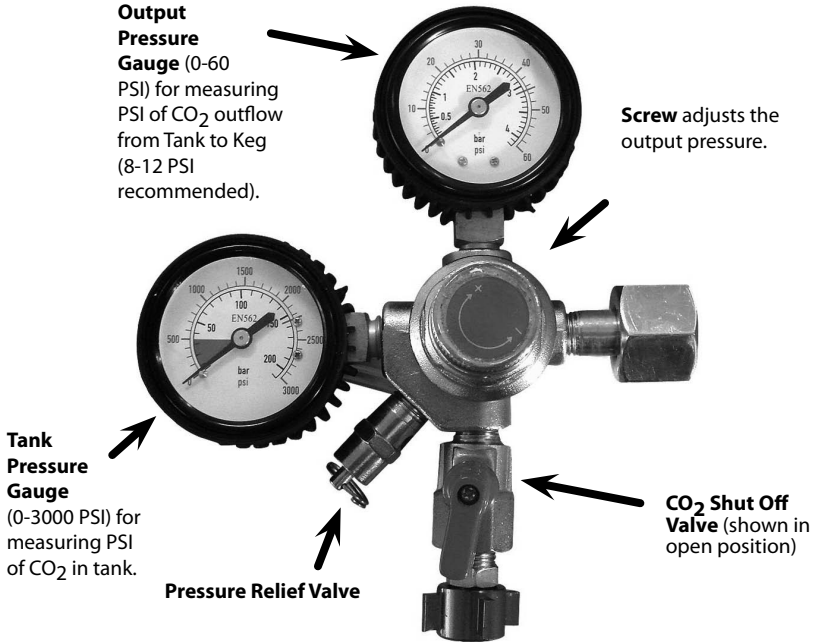

1. Close the Shut Off Valve on the Double Regulator, and open the CO₂ Tank Valve (#9) completely.
2. Unlock Screw using Allen Wrench (included). Slowly turn the Double Regulator adjustment screw until the desired pressure is shown on the Output Pressure Gauge (8-12 PSI). Turning clockwise will increase the output pressure, and turning counter-clockwise will decrease the output pressure.
3. Once desired pressure is reached, you may re-lock Screw using Allen Wrench.
4. Open the CO₂ Shut Off Valve on the Double Regulator to allow gas flow from the Double Regulator to the Keg Coupler. You will hear the keg pressurizing. The output needle will drop momentarily until the pressure has equalized. Then the needle will return to the point you set it at.
5. The Keg Coupler is designed with a pressure relief valve (PRV). Pull the ring on the PRV briefly to allow gas to vent. This will permit gas to flow through the Double Regulator and help obtain a more accurate reading on the Output Pressure Gauge.
6. Re-check the output pressure on the Double Regulator, and if necessary re-adjust using step #2 until the desired pressure is shown. It is always wise to follow up any adjustment to the Double Regulator with a brief pull of the PRV ring to ensure an accurate output reading.

INSTALLING THE CASTERS

Follow the steps below to install the Casters.

Note: Two of the Casters include locking mechanisms to ensure the unit does not slide on hard floors. These two locking Casters should be fastened at the front end of the unit, with the unlocked Casters fastened on the rear end.

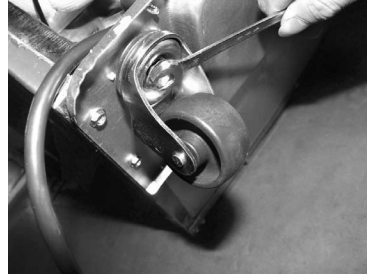

1. Empty the inside of the cabinet completely and lay the KEGORATOR™ down on it's side. We recommend that you place a piece of cardboard or cloth underneath the cabinet to prevent dents or scratches.
2. Place washers over Caster bolts, then insert the Casters into the holes on the bottom corners of the cabinet. Tighten each Caster by turning the nut clockwise with a wrench (not provided in the kit).
3. Once all four Casters have been tightened, stand the cabinet in its upright position.

INSTALLING THE GUARDRAIL

Follow the steps below to install the Guardrail.

1. Place the Guardrail on top of the KEGORATOR™
2. Align all holes of the Guardrail with the holes on the top of the KEGORATOR™
3. Secure the Guardrail to the KEGORATOR™ by placing inside corresponding holes.

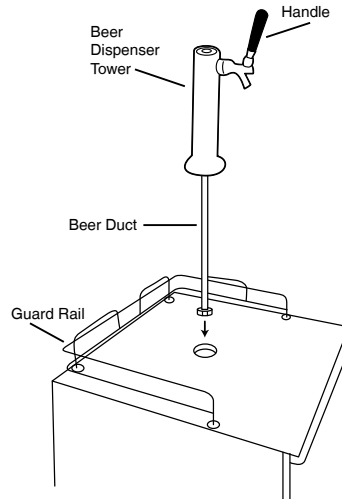

CO₂ & TAP TOWER INSTALLATION

You must read and understand the steps below for the CO₂ assembly before installation. When you purchase the first keg of beer, you must also have your CO₂ cylinder filled at your local supplier. CO₂ tanks can be refilled at locations such as welding supply shops, party stores, or wherever kegs are purchased.

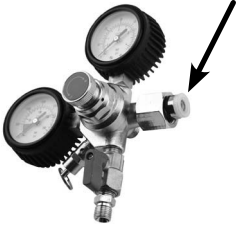

STEP 1

Make sure white nylon High Pressure Washer (already installed) is attached to CO₂ Double Regulator.



STEP 2

Use Wrench to attach Double Regulator to CO₂ Tank connector.



STEP 3

Remove spring from inside the Keg Coupler. If spring is not present, go on to **Step 4**.

STEP 4

Make sure Backflow Stopper is inserted in the Keg Coupler (the Backflow Stopper goes in with rounded side down).

STEP 5

After the Backflow Stopper has been inserted, remove the three parts above.

(cont. on next page)

STEP 6

The CO₂ Rubber Directional Washer goes back into the Keg Coupler.



STEP 7

Connect the CO₂ line from the Double Regulator to the Keg Coupler.

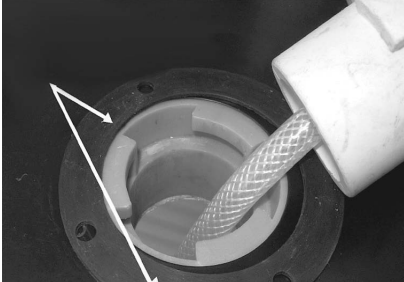

STEP 8

Place the Beer Tower Washer (#5) over the hole. Place the Tap Tower on the KEGORATOR™ and feed the hose line through the hole in the top of the KEGORATOR™

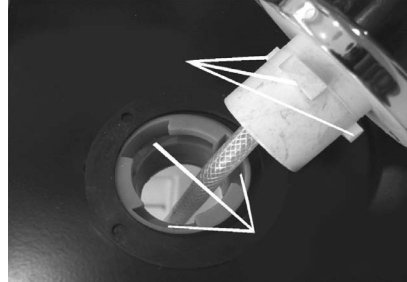

STEP 9

Make sure the notches in the Tap Tower fit into the holes in the top of the KEGORATOR™ Tighten the Tap Tower by twisting until it locks in place.



STEP 10

Place Coupler Washer (#3) on top of the Keg Coupler.



STEP 11

After the Tap Tower has been placed on the KEGORATOR™ and the hose line feeds through the bottom, attach the wing nut to the Keg Coupler.

Complete CO₂ Tank Installation

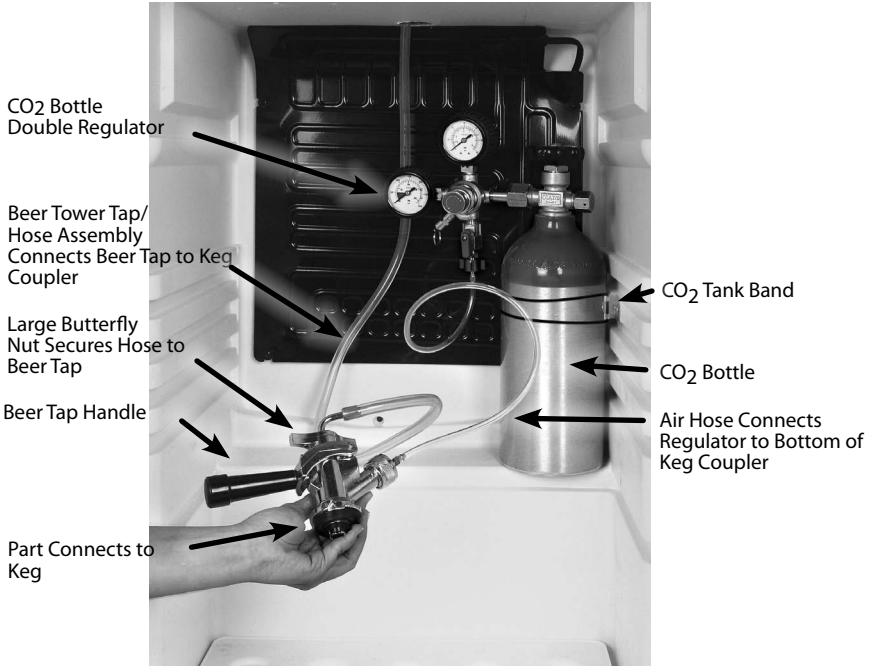



DANGER!
CO₂ can be dangerous! CO₂ cylinders contain high-pressure gas, which can be hazardous if handled improperly. They must be handled with care.

Location of Temperature Gauge

The temperature gauge is located in the lower left-hand corner in the back of the KEGORATOR™

MAX= Increases Coolness / **MIN**= Decreases Coolness / **OFF** = Turns Off



TAPPING THE BEER KEG

(SINGLE VALVE-TYPE KEG)

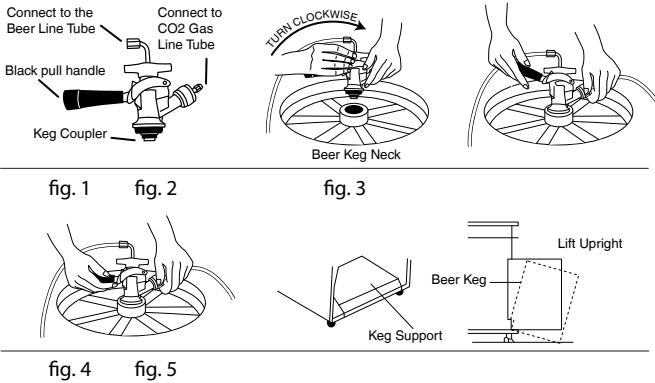

Follow these steps below to tap the Beer Keg.

1. Make sure the black pull handle of the Keg Coupler is in the closed (up) position before installing it on the keg (Fig. 1). Insert the Keg Coupler into the locking neck of the Beer Keg and turn clockwise until it locks into position (Fig. 2). This means that it is secured to the Beer Keg.
2. Make sure the Beer Tower Faucet is in the closed (handle pointing straight back) position before connecting the Keg Coupler to the Keg (Fig. 3). To secure the tank connection, pull the Keg Coupler handle out and push down until it locks into position. Listen for the “click” of the pull handle when it shifts into the final downward position (Fig. 4). This will open the beer and CO₂ gas valves. The Keg is now tapped.
3. Carefully tilt the Keg and rest the edge on the Keg Base Board on the bottom of the Interior Cabinet. Slide the Beer Keg slowly, ensuring that it is properly located (Fig. 5) and carefully close the door.

HOW TO OPERATE

Follow the steps below to dispense beer.

1. Make sure that the KEGORATOR™ is plugged in properly to a 120V, 60Hz, 15 Amps grounded AC outlet.
2. Place the drip tray under the beer faucet to avoid messes from excess beer.
3. Open the beer faucet by pulling the tap towards you to dispense the beer. If for any reason the beer does not come out of the tap, please refer to the **Tapping the Beer Keg** section.
4. Increase the pressure if the beer runs too slowly (see Regulator section).
5. Hold the glass steady at a 45° angle. When it is $\frac{2}{3}$ full, straighten the glass. Proper foam should be a tight creamy head and the collar on an average glass should be $\frac{3}{4}$ " to 1" high, ideally.

HELPFUL TIPS

- It is recommended that you flush the hoses with water prior to first use to remove any dust and debris from shipping.
- Only open the CO₂ Tank ¼ turn to begin with and then use the regulator to adjust to desired pour. If it is not enough, continue to open the CO₂ Tank by ¼ turn and use regulator until desired setting is reached.
- It is normal to see condensation form on the faucet. It is caused by the difference in temperature between the cold beer and the inside of the faucet when beer is flowing through the line.
- If your CO₂ Tank Band breaks during assembly, it is recommended to use a bungee cord to secure CO₂ Tank.
- Humidity can cause ice to build up inside the KEGORATOR™, so you will need to periodically defrost it. There is a hole in the back of the unit that will allow water to drain out of the KEGORATOR™.

Foamy Beer

Follow these steps to prevent foamy beer:

- Confirm the packing spring in the Coupler is removed and discarded. It is not to be placed inside the Coupler when unit is assembled.
 - Make sure there is only (1) Backflow Stopper inserted and it falls out easily if the Coupler is flipped over. If you have to force it out with a screwdriver, it is getting lodged in the Coupler. Try exchanging it with the replacement.
 - Confirm the beer lines are not kinked and are clean.
- To prevent foamy beer, you may need to bring down your pressure, even if it is below the recommended 8-12 PSI:
- Before lowering the pressure, close the CO₂ Shut Off Valve (turn to 9 o'clock position) and use the provided 1.5mm Allen Wrench to loosen the Allen Screw on the red +/- adjustment dial. This will restrict excess CO₂ from entering the keg.
 - Adjust the pressure down to 6 PSI. Lock the red +/- dial back in place by tightening with the Allen Wrench.
 - Pull the Release Valve on the Regulator to get an accurate reading of CO₂ pressure.
 - With the Shut Off Valve still closed, move down to your Coupler.
 - Pull the release valve on the Coupler to remove any excess CO₂ that may have been pushed into the keg at another point.
 - Once most or all has released, open the Shut Off Valve (6 o'clock position) and attempt to pour a beer.

This should prevent and/or correct foamy beer.

- Keep in mind that jostling a keg can create foamy beer.
- Temperature also may affect the beer, so be sure it is not too warm or too cold. 37 degrees F is an ideal temperature.
- A faulty valve on the keg itself may cause the Coupler to not seat well. Make sure all connections are secure and tightened (not just tightened by hand). Ensure all O-rings and Washers are intact and correctly placed. Confirm Directional Washer (#4) has a hole in it when pinched between the fingers.

CLEANING & MAINTENANCE

Follow the steps below to clean the keg tap and hoses. (see illustration below)

1. Turn off CO₂ completely before attempting to clean.
2. Remove the hose from the coupler and carefully twist the dispenser faucet off the top of the KEGORATOR™
3. Ensure that the dispenser handle is in the down position before flushing the hose. If this is not set correctly, water cannot flow through. Hold the open end of the hose under running water for 3-5 minutes, while the beer dispenser faucet drains into the sink. This will clear any excess beer that is trapped inside, helping to prevent any bacteria or mold that could accumulate inside.
4. In order to clean and remove any excess beer that may leak into the unit space inside the door, remove the black rubber insulation and wipe with a wet towel as needed.

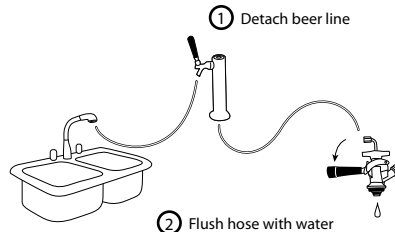

Follow the guidelines below to care for your KEGORATOR™ when not in use.

- Please adjust the temperature gauge to MIN in colder environments because this unit does not self-defrost and ice may build up inside the unit. The temperature gauge is located on the back side of the KEGORATOR™ inside the cut out area at the bottom to the lower left.
- Always rinse the beer line if you do not intend to use your KEGORATOR™ for a period of time. First, turn off the CO₂ and dispense beer until it stops. This will release pressure in the keg so that the coupler can safely be detached.
- To avoid permanent damage to the unit, never use sharp objects inside the KEGORATOR™

RETURNS & WARRANTY

SHOULD YOUR UNIT NOT WORK OR IF DAMAGED WHEN YOU FIRST TAKE IT OUT OF THE BOX, PLEASE RETURN IT TO THE PLACE OF PURCHASE IMMEDIATELY.

KEGORATOR™ / KRS2100 SERIES

Should you have any questions, please contact us via email or at the customer service number listed below between the hours of 8:00 AM and 5:00 PM, Monday through Friday, Central Standard Time.

Distributed by:

Nostalgia Products Group LLC
1471 Partnership Dr.
Green Bay, WI 54304-5685
Customer Service
Phone: (920) 347-9122
Web: www.nostalgiaelectrics.com

Customer Service Inquiry

To submit a Customer Service inquiry, go to www.nostalgiaelectrics.com and fill out the Customer Service Inquiry form and click the Submit button.

A representative will contact you as soon as possible.

This appliance is designed and built to provide many years of satisfactory performance under normal household use. The distributor pledges to the original owner that should there be any defects in material or workmanship during the first 90 days of purchase, we will repair or replace the unit at our option. Our pledge does not apply to damages caused by shipping, mishandling or unit being dropped. A product deemed defective either from manufacturing or being mishandled is up to the distributor's discretion. In order to obtain service under this warranty, please contact Nostalgia Products Group, LLC at the telephone number listed above or by filling out the Customer Service Inquiry Form located at www.nostalgiaelectrics.com.

This product is not recommended for use outside of North America. The warranty is void if products are exported outside of the USA, Canada or Mexico.

This warranty does not apply to re-manufactured merchandise.

Please read these instructions carefully. Failure to comply with these instructions, damages caused by improper replacement parts, abuse or misuse will void this pledge to you and is being made in place of all other expressed warranties.

For more information, visit us online at www.nostalgiaelectrics.com.

Like us on Facebook at www.facebook.com/NostalgiaElectrics.