

Failure to return this card will not diminish your warranty rights.

Copyright © 2011 All Rights Reserved

Please seal with tape. Do not staple.

FOLD LINE  
Seal with tape, DO NOT STAPLE

TAPE HERE

Please do not send products and other correspondence to this address

T C D



**BUSINESS REPLY MAIL**  
FIRST-CLASS MAIL PERMIT NO. 828 DENVER, CO

POSTAGE WILL BE PAID BY ADDRESSEE

**BUSH INDUSTRIES**  
**PO BOX 174364**  
**DENVER CO 80217-9852**

TAPE HERE

NO POSTAGE  
NECESSARY  
IF MAILED  
IN THE  
UNITED STATES

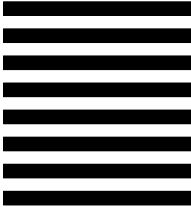

CUT LINE

**PLEASE RETAIN THIS FOR YOUR RECORDS**

You may need to refer to this information in case of warranty claim or for insurance purposes.

Date Purchased: \_\_\_\_\_

Store Name: \_\_\_\_\_

Model # \_\_\_\_\_

Product Description: \_\_\_\_\_

Register online at:  
[www.bushfurniture.com/register](http://www.bushfurniture.com/register)



FOLD LINE

MODEL: MY72717

Failure to return this card will not diminish your warranty rights.

A168172

When folded this is the  
OUTSIDE FLAP

We want to hear from you . . .

Register online at:

[www.bushfurniture.com/register](http://www.bushfurniture.com/register)

Or return this completed product registration card within the next 10 days to receive these important benefits:

**1. Customer Service**

Return your product registration within ten days. The sooner we have your information, the better we will be able to help you.

**2. Protect Your Product**

We will keep the model number and Bush product on file to help you refer to this information in the unlikely event you require replacement parts or need to file an insurance claim.

**3. Register Your Purchase**

Returning this registration card is the only way to guarantee that you will be notified by Bush of any issues that arise concerning this product.

YOUR PARTICIPATION IS GREATLY APPRECIATED  
Thank you for choosing Bush and for taking the time to register your product. Your participation will help us better serve you in the future.

If you have any comments or suggestions about our product, please write to:

**Consumer Service Department**  
One Mason Drive  
Jamestown, NY 14701  
1-800-950-4782  
[ConsumerService@BushIndustries.com](mailto:ConsumerService@BushIndustries.com)

TO SAVE POSTAGE AND TIME, PLEASE REGISTER ONLINE:  
[WWW.BUSHFURNITURE.COM/REGISTER](http://WWW.BUSHFURNITURE.COM/REGISTER)

**1. Product Numbers. You can use this form to register multiple products at one time.**

<b>Product Model Number</b>	<input type="text"/>
<b>Lot Code Number</b>	<input type="text"/>
<b>Product Model Number</b>	<input type="text"/>
<b>Lot Code Number</b>	<input type="text"/>
<b>Product Model Number</b>	<input type="text"/>
<b>Lot Code Number</b>	<input type="text"/>
<b>Product Model Number</b>	<input type="text"/>
<b>Lot Code Number</b>	<input type="text"/>
<b>Product Model Number</b>	<input type="text"/>
<b>Lot Code Number</b>	<input type="text"/>

T C D



**2. Contact Information.**

Mr.  Mrs.  Ms.

<b>First Name</b>	<input type="text"/>	<b>Initial</b>	<input type="text"/>	<b>Last Name</b>	<input type="text"/>
-------------------	----------------------	----------------	----------------------	------------------	----------------------

**E-mail**

<b>Street Address</b>	<input type="text"/>	<b>Apt. No.</b>	<input type="text"/>
-----------------------	----------------------	-----------------	----------------------

<b>City</b>	<input type="text"/>	<b>State/Province</b>	<input type="text"/>	<b>ZIP Code</b>	<input type="text"/>
-------------	----------------------	-----------------------	----------------------	-----------------	----------------------

Please take the time to answer these two brief survey questions.

**3. What three (3) factors most influenced your furniture purchase?**

- 1)  Quality
- 2)  Durability
- 3)  Affordability (lower price)
- 4)  Value for price
- 5)  Work surface size
- 6)  Storage space
- 7)  Product layout in your space
- 8)  Style/aesthetics
- 9)  Color/finish
- 10)  Warranty
- 11)  Brand name
- 12)  Product was in stock
- 13)  Fast delivery
- 14)  Ease of assembly
- 15)  Ease of transport
- 16)  Customer service support
- 17)  Space Planning service
- 18)  Delivery and installation service
- 19)  Other

**4. What was the main reason for this purchase?**

- 1)  Old furniture needed to be replaced
- 2)  New space/location
- 3)  New business
- 4)  Expanding business (new employees)
- 5)  New space plan to improve productivity
- 6)  Remodeling/redecorating
- 7)  Bought a new TV

I do not want to receive coupons, mailings, or other special offers.

Take advantage of these benefits. Register today!

- Expert customer service
- Exclusive product offers and special promotions
- Guaranteed replacement parts

**SAVE TIME!**

**REGISTER ONLINE.**

[www.bushfurniture.com/register](http://www.bushfurniture.com/register)

MODEL MY72717

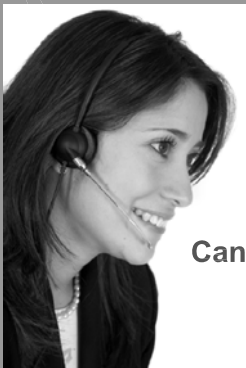

Can we help you ?

THE BUSH FURNITURE

# Difference

- QUALITY
- INNOVATION
- SERVICE
- VALUE

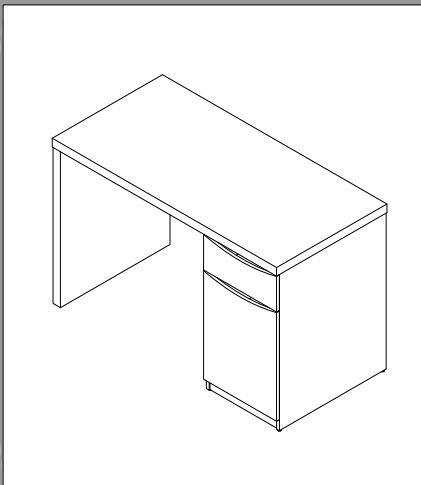

A170040



**Thank you for purchasing** this Bush Furniture product. We trust that you will be completely satisfied with your product for many years to come. Bush Furniture products are backed by a 1-year warranty and crafted with today's styles in mind for the way you work. **Do not return product to store - contact us first at 1-800-950-4782.**

**Merci d'avoir acheté** ce produit Bush Furniture. Nous sommes sûr que vous serez complètement satisfait de votre meuble pendant de nombreuses années. Les produits Bush Furniture sont garantis pendant 1 an et sont conçus dans les styles actuels tout en gardant à l'esprit votre façon de travailler. **Ne renvoyez pas le produit au magasin, contactez-nous d'abord au 1-800-950-4782.**

**Gracias por comprar** este producto de Bush Furniture. Confiamos que usted estará completamente satisfecho con su mueble por muchos años. Los productos de Bush Furniture tienen 1 año de garantía y son diseñados con los estilos de hoy en mente para la manera que usted vive. **No devuelva el producto a la tienda, primero comuníquese con nosotros al 1-800-950-4782.**





# IT'S AS EASY AS 1,2,3

## Assembly tips:

1. Read the instructions and become familiar with the parts.
2. Ensure this carton contains all parts, fasteners and hardware.
3. To protect floors, assemble the furniture on the carton.
4. An assistant may be helpful.
5. Use of power tools is not recommended.

## Conseils d'assemblage:

1. Lisez les instructions et familiarisez-vous avec les pièces.
2. Assurez-vous que le carton contient toutes les pièces, toutes les pièces de fixation et toute la quincaillerie.
3. Pour protéger vos sols, assemblez le meuble sur le carton.
4. Il peut être utile de vous faire aider.
5. L'utilisation d'outils électriques n'est pas recommandée.

## Consejos de Ensamblaje:

1. Lea las instrucciones y familiarícese con las partes.
2. Asegúrese de que esta caja contenga todas las piezas, los sujetadores y el equipo.
3. Para proteger el piso, ensamble el mueble en el carton.
4. Un asistente puede serle útil.
5. El uso de herramientas eléctricas no se recomienda.



M - F 8:30 a.m. - 7:30 p.m. ET  
(Except Holidays)

Bush Consumer Services  
One Mason Drive  
Jamestown, NY 14701  
ConsumerService@BushIndustries.com

1-800-950-4782 USA/CANADA

1-800-950-4782 MEXICO

Se habla español

Outside USA/CANADA/MEXICO

001-716-665-2510 Ext. 5900



## CONSUMER SERVICE YOU CAN DEPEND ON

Questions? Operators are standing by at our TOLL-FREE help line to assist you with assembly; and, if necessary, to quickly replace damaged/missing parts. Assistance is available 5 days a week. Simply have your store receipt, instruction manual, and part number/description ready when you call our TOLL -FREE help line. It's that easy.

UN SERVICE CLIENTELE SUR LEQUEL VOUS POUVEZ COMPTER  
Des questions? Des opérateurs sont prêts sur notre ligne d'assistance GRATUITE pour vous aider à l'assemblage et, si nécessaire, remplacer rapidement les pièces endommagées/manquantes. L'assistance est disponible 5 jours par semaine. Ayez simplement votre reçu de magasin, votre manuel d'instruction et le numéro de pièces/description à votre disposition lorsque vous appelez notre ligne d'assistance GRATUITE. C'est aussi simple que ça.

SERVICIO AL CONSUMIDOR CON EL QUE PUEDE CONTAR  
¿Preguntas? Los operadores están listos para ayudarlo con el ensamblaje a través de una línea de ayuda GRATUITA, y en caso de ser necesario, reemplazar de inmediato las piezas dañadas o faltantes. La asistencia está disponible los 5 días de la semana. Solamente tenga listos su recibo de compra, manual de indicaciones y número/descripción de la pieza al momento de llamarnos a la línea de ayuda GRATUITA, Es así de sencillo.

# IMPORTANT SAFETY INFORMATION



## WARNING

Do not move unit when loaded. Doing so could cause instability, product collapse, tip over, and/or serious injury.

---

No mueva la unidad cuando esté cargada. Hacerlo puede causar inestabilidad, que el producto se derrumbe, que se la caiga encima y/o heridas (golpes) serias.

---

Ne pas déplacer l'unité lorsqu'ell est chargée. Faire ainsi peut causer l'instabilité, l'effondrement ou le renversement du meuble et/ou des endommagements sérieux.



## WARNING

This product is designed and intended for use with computer, fax, and printer equipment only. Improper loading with television or other heavy equipment could cause instability, tip over, and/or serious injury.

---

Este producto esta diseñado solamente para el uso con computadores, faxes, e impresoras. Inapropiado uso al poner televisores u otro equipo pesado puede causar inestabilidad, rodamiento, y/o herida (golpes) serios.

---

Ce produit est uniquement conçu pour une utilisation avec un ordinateur, un télécopieur, ou une imprimante. Un chargement incorrect avec une télévision ou autre matériel lourd peut le rendre instable ou le renverser, et peut vous causer des endommagements sérieux.

# EXPLODED VIEW

MODEL MY72717

A [1]	W170041	I [1]	W170045
B [1]	W170042	J [1]	W167444
C [1]	W167437	K [1]	W170046
D [1]	W170043	L [1]	W170047
E [1]	W170044	M [1]	W170048
F [1]	W167440	N [1]	W167448
G [1]	W167441	O [1]	W170049
H [1]	W167442		

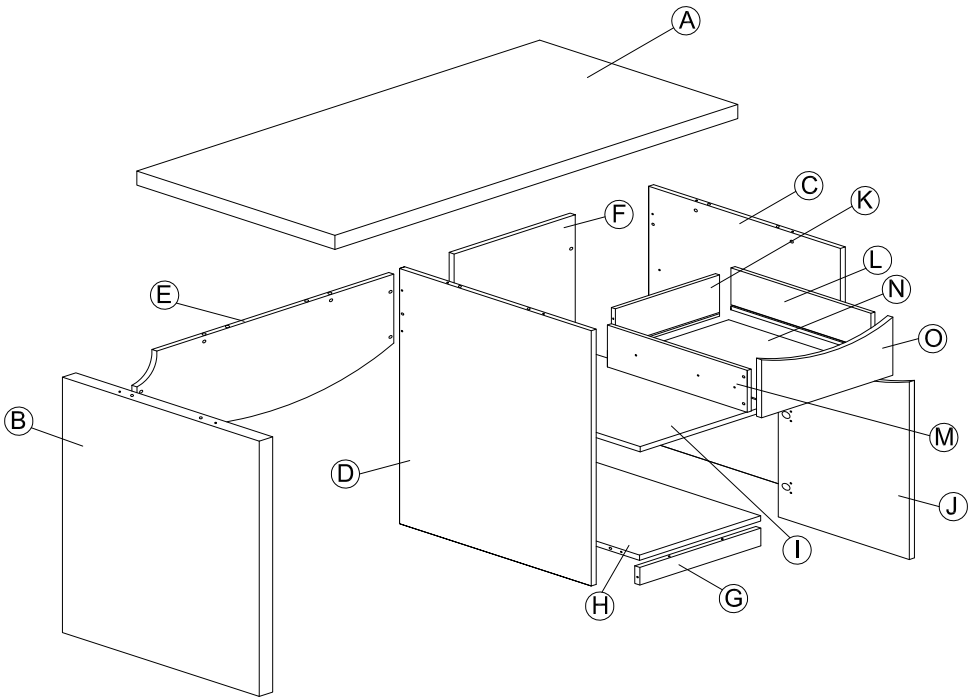
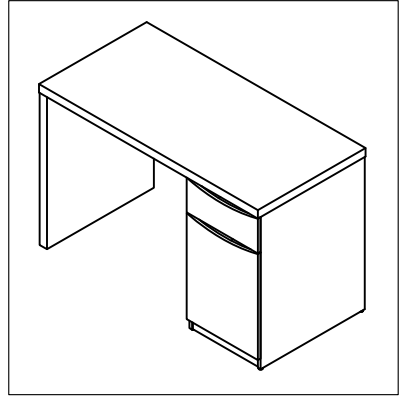

# FASTENERS

Fasteners are shown in actual size.

Los fijadores son demostrados en su tamaño actual.

Les attaches sont montrées dans l'échelle grandeur.

H159917

Quantity  
**22**

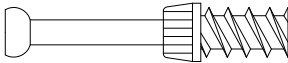

H159916

Quantity  
**22**

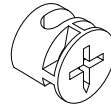

H35251

Quantity  
**4**

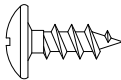

# 10 x 1/2"

H38169

Quantity  
**20**

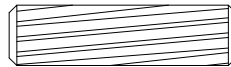

8x30mm

H101725

Quantity  
**18**

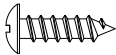

#6 x 1/2"

H167433

Quantity  
**4**

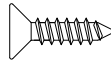

#6 x 9/16"

H160339

Quantity  
**6**

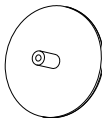

H167373

Quantity  
**2**



H23198

Quantity  
**4**

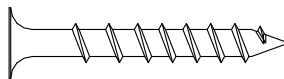

# 10 x 1-1/2"

# HARDWARE

H156359

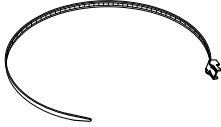

Quantity  
**2**

H157328



Quantity  
**2**

H166951



16"

Quantity  
**2**

H23604

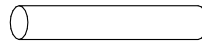

Quantity  
**4**

H149989



Quantity  
**2**

H126396



Quantity  
**4**

H20385

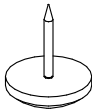

Quantity  
**6**

H100445



Quantity  
**2**

H170051

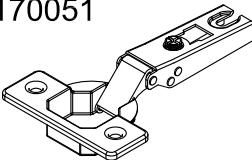

Quantity  
**2**

H170050

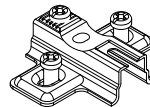

Quantity  
**2**



**Common assembly techniques.**  
**Técnica común de ensamblaje.**  
Techniques communes d'assemblage.

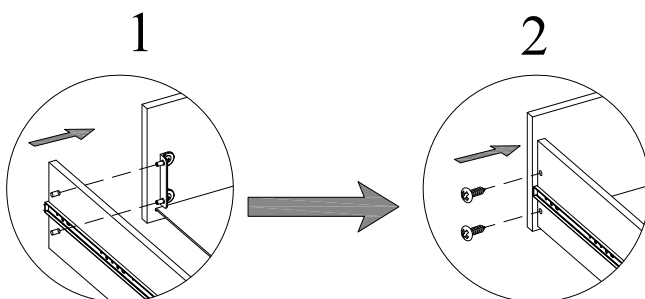
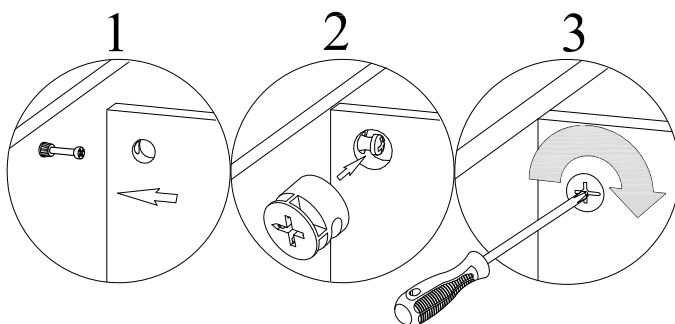
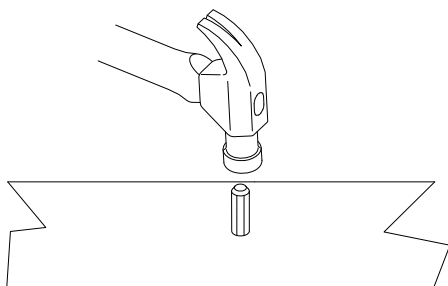

**Common assembly techniques.**  
**Técnica común de ensamblaje.**  
Techniques communes d'assemblage.

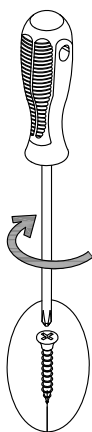

1

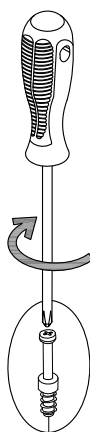
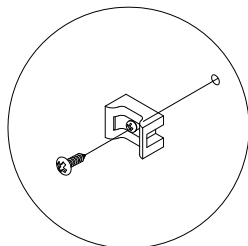

2

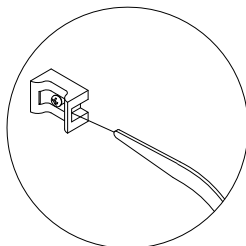

3

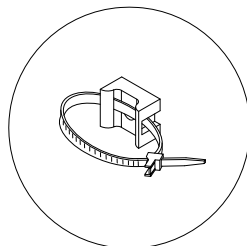

**Common assembly techniques.**  
**Técnica común de ensamblaje.**  
**Techniques communes d'assemblage.**

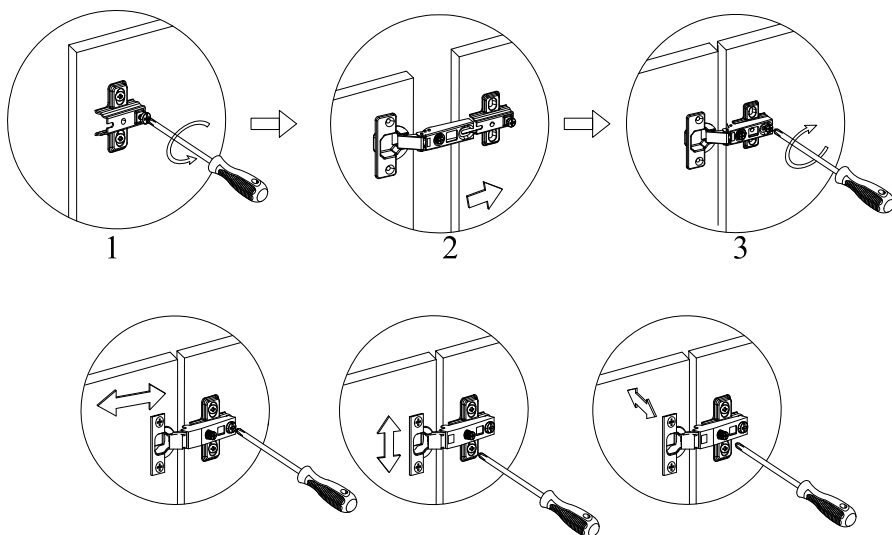



# STEP 2

H38169



[ 10 ]

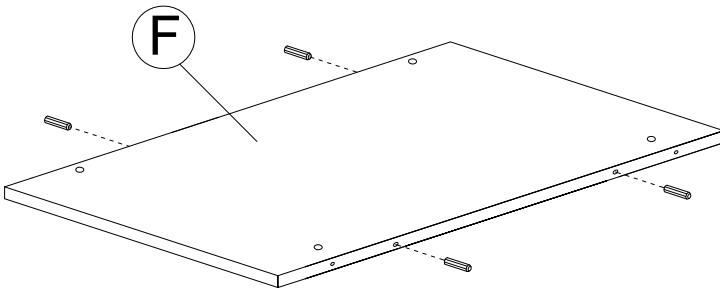
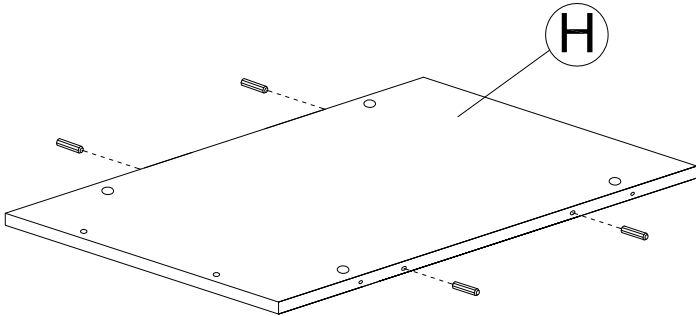
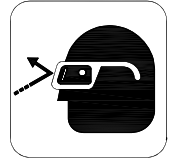
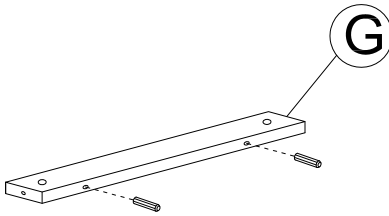

## STEP 3

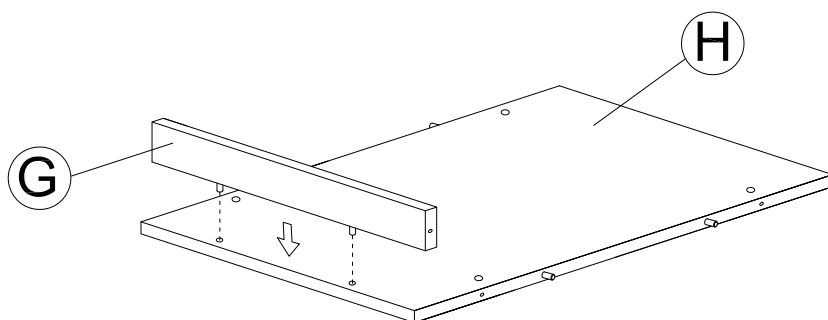

# STEP 4

H159916

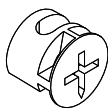

[ 3 ]

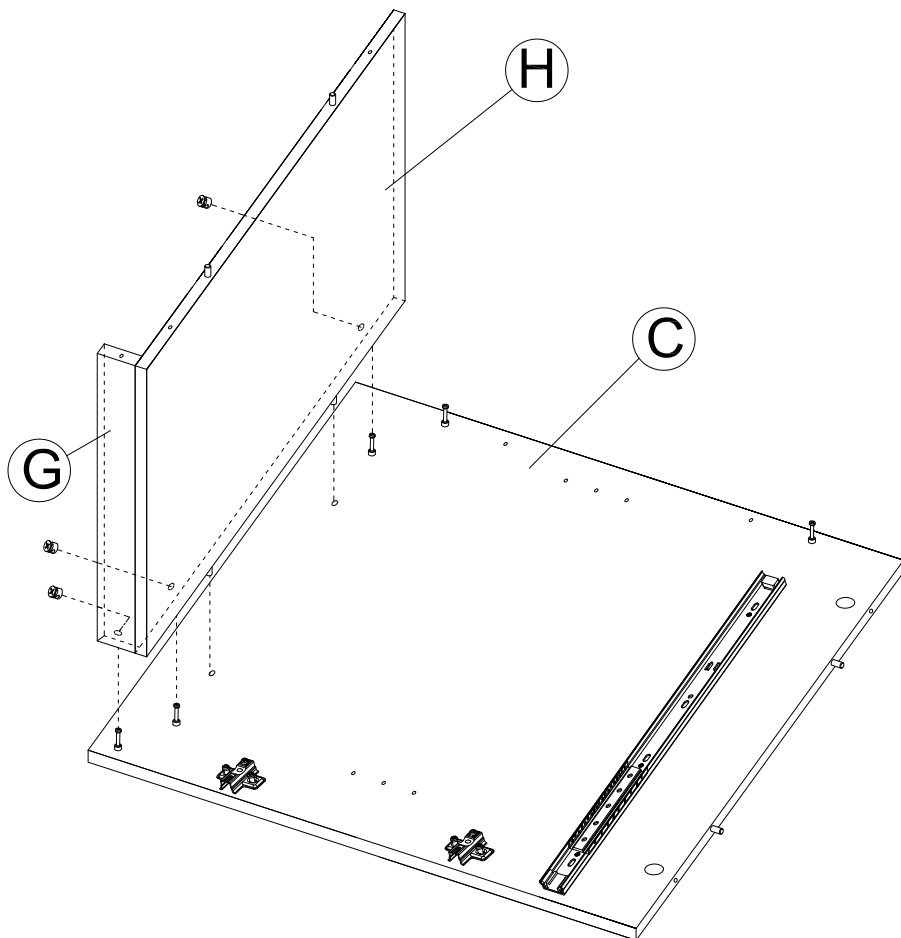

# STEP 5

H159916

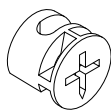

[ 2 ]

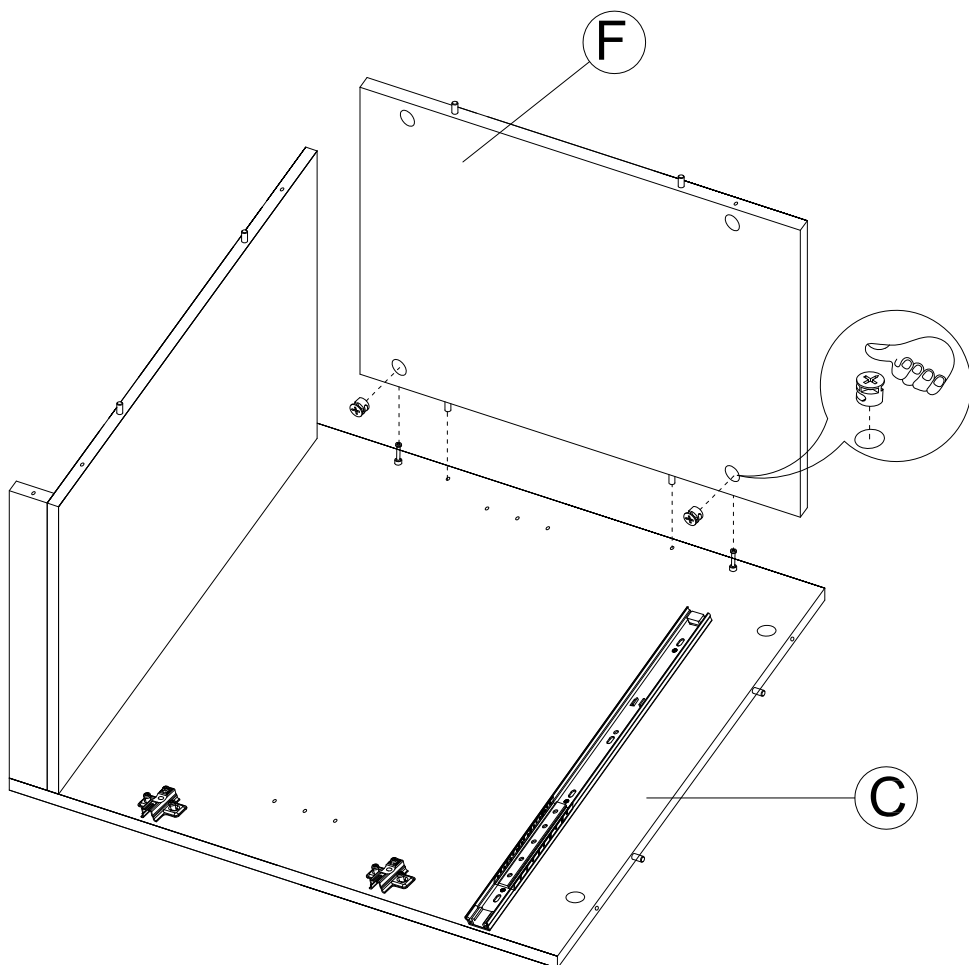



1 - 800 - 950 - 4782

A170040

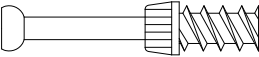

# STEP 6

H159917  [ 5 ] H38169  [ 2 ]

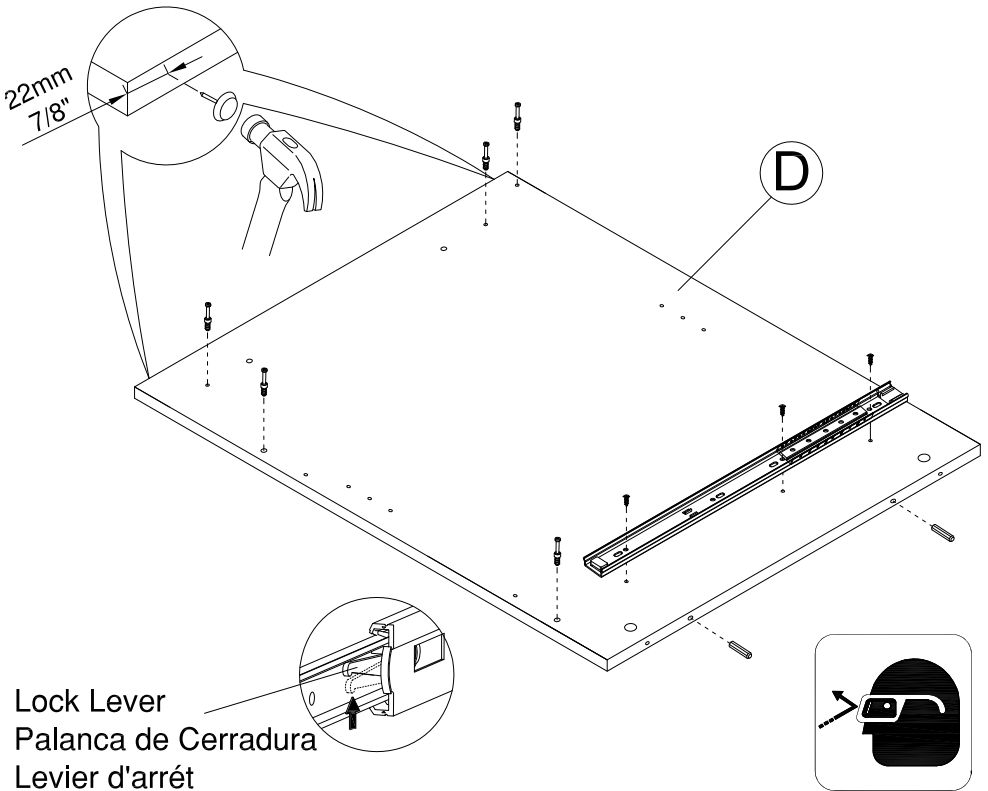

H101725  [ 3 ] H20385  [ 2 ]

H166951  [ 1 ]

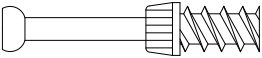

Move lock lever on the drawer runner as shown and separate drawer runner from drawer slide.  
Mueva Palanca de la Cerradura en la corredera como se muestra y separe la corredera del deslizable.  
Relever le Levier d'arrêt sur la coulisse pour tirer et séparez le coulisseau de la coulisse tel que montré.

# STEP 7

H159917  [ 2 ] H159916  [ 5 ]

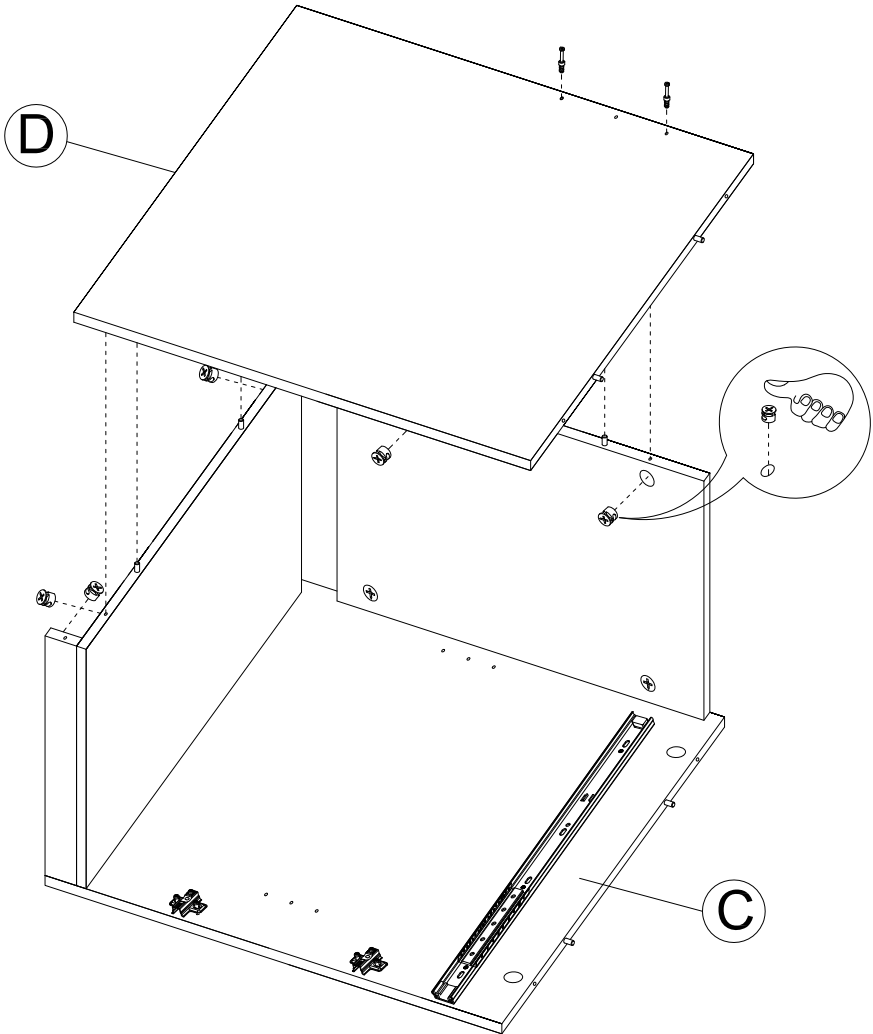

# STEP 8

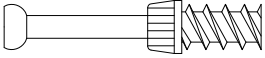
H159917  [ 2 ]

H20385  [ 2 ]

H38169  [ 6 ]

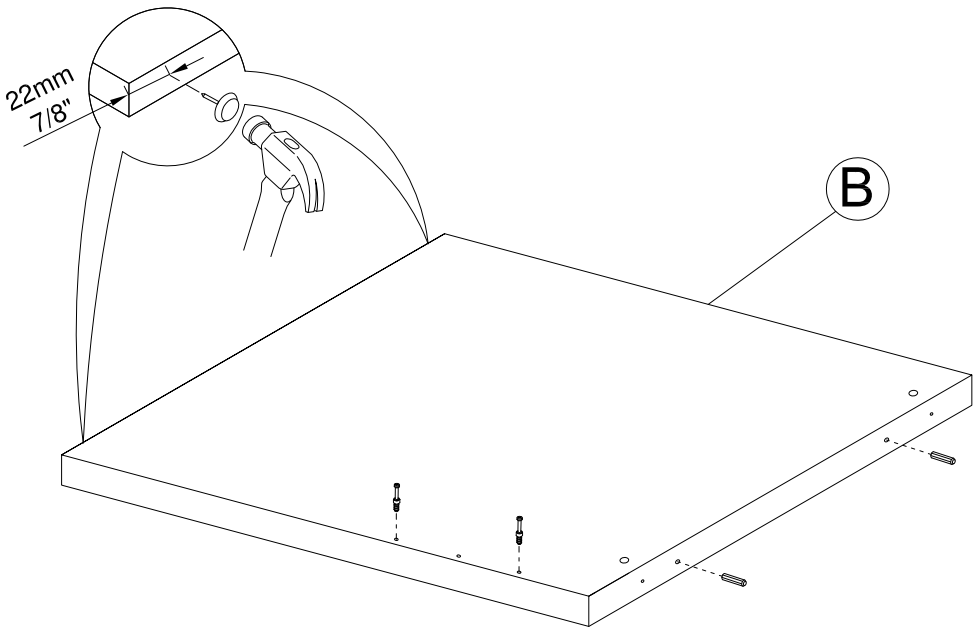
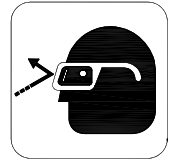
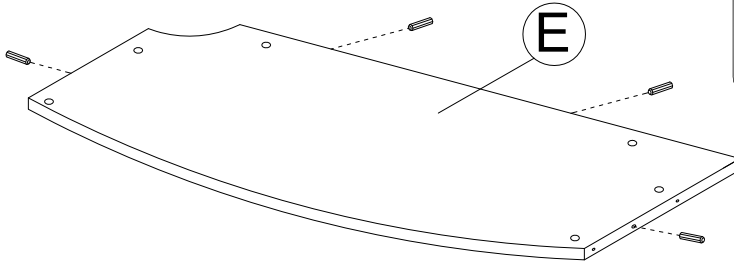

## STEP 9

H159916

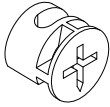

[ 4 ]

An assistant is required.  
Es necesario un ayudante.  
Un assistant est nécessaire.

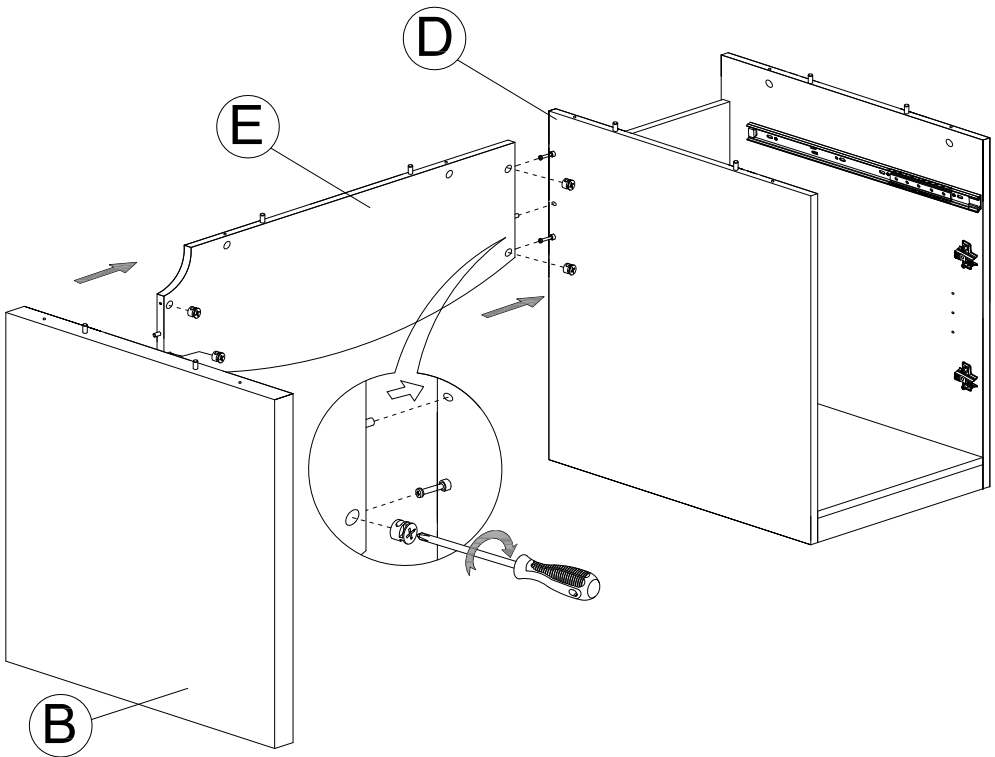

# STEP 10

H159917

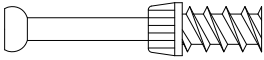

[ 8 ]

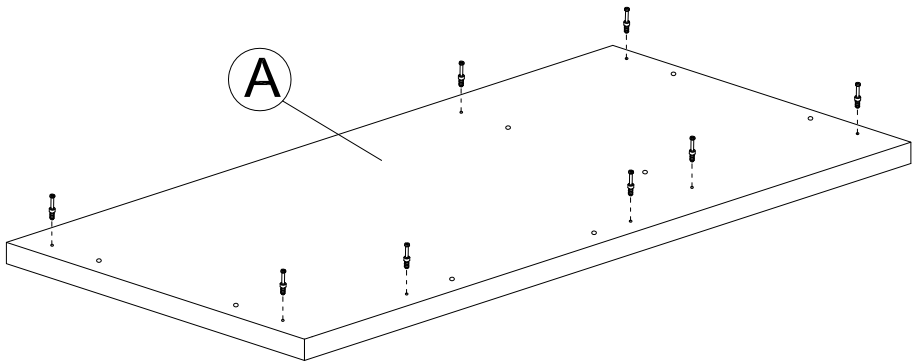

# STEP 11

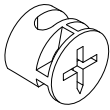
H159916  [ 8 ]

H160339  [ 6 ]

H167373  [ 2 ]

An assistant is required.  
Es necesario un ayudante.  
Un assistant est nécessaire.

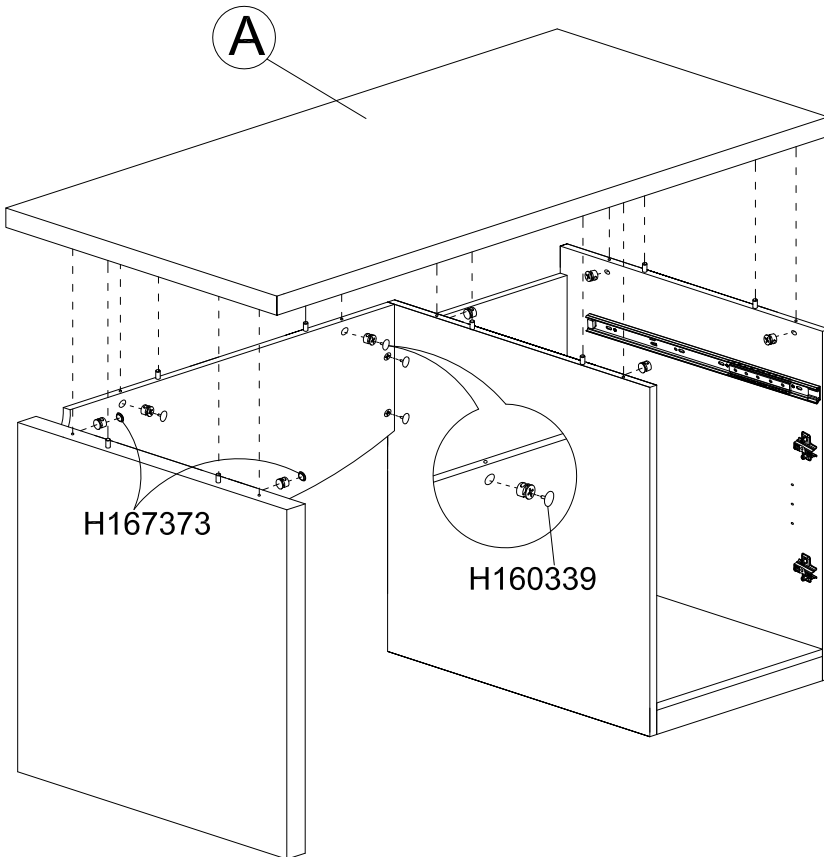

# STEP 12

H170051

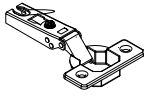

[ 2 ]

H149989



[ 2 ]

H167433

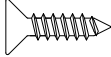

[ 4 ]

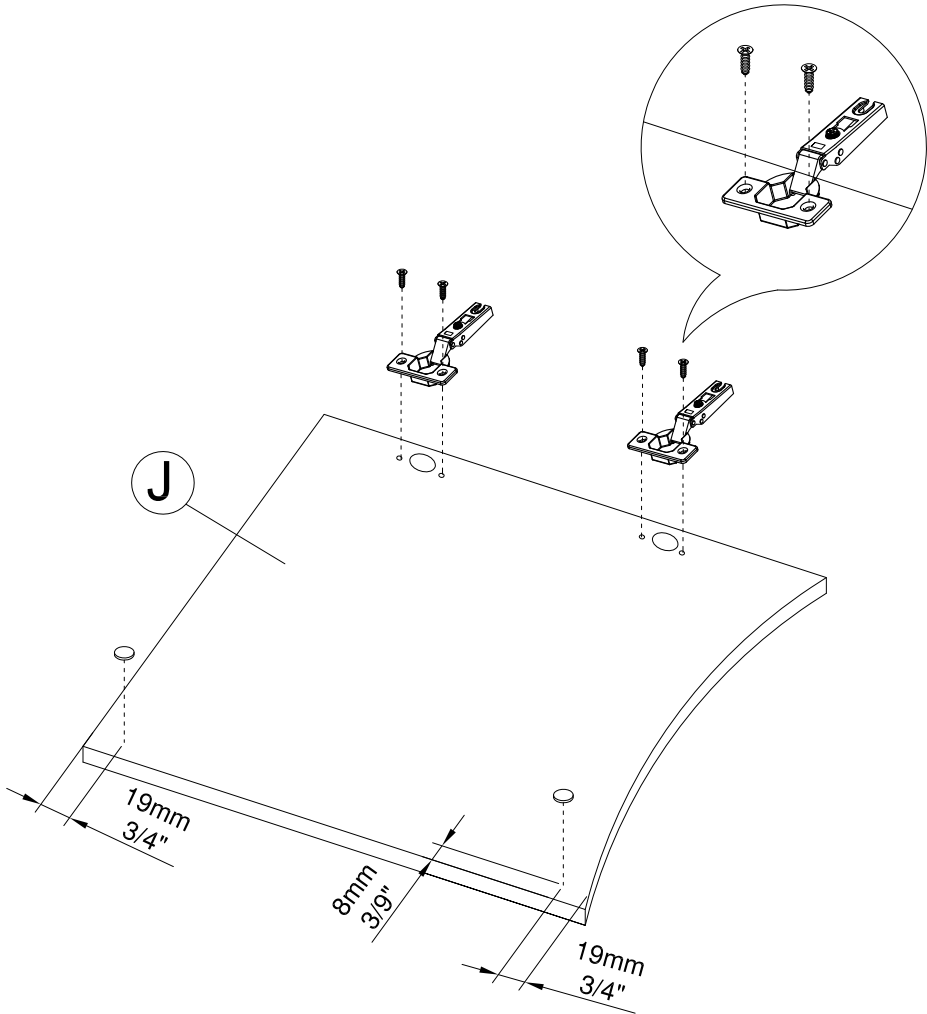

# STEP 13

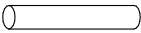
H23604  [ 4 ]

H126396  [ 4 ]

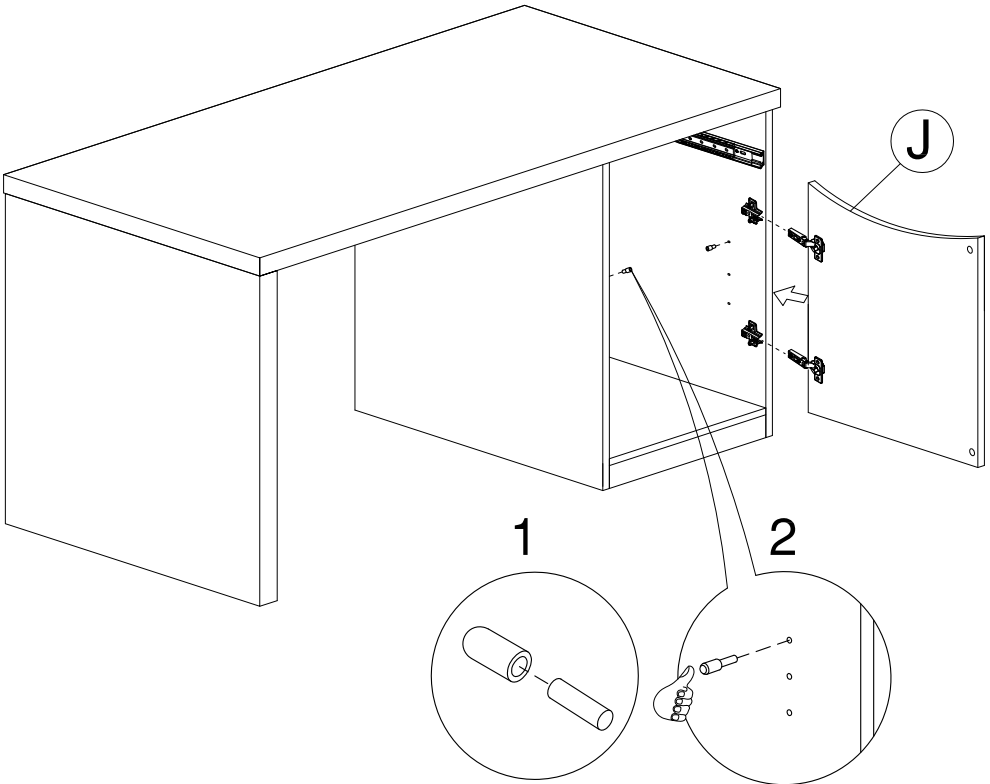
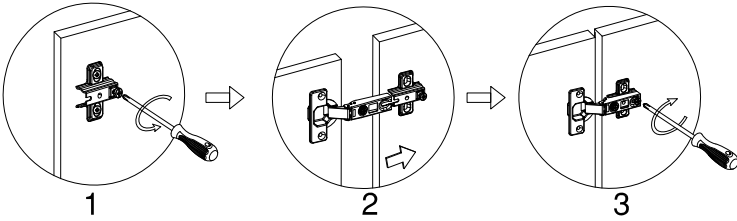



# STEP 14

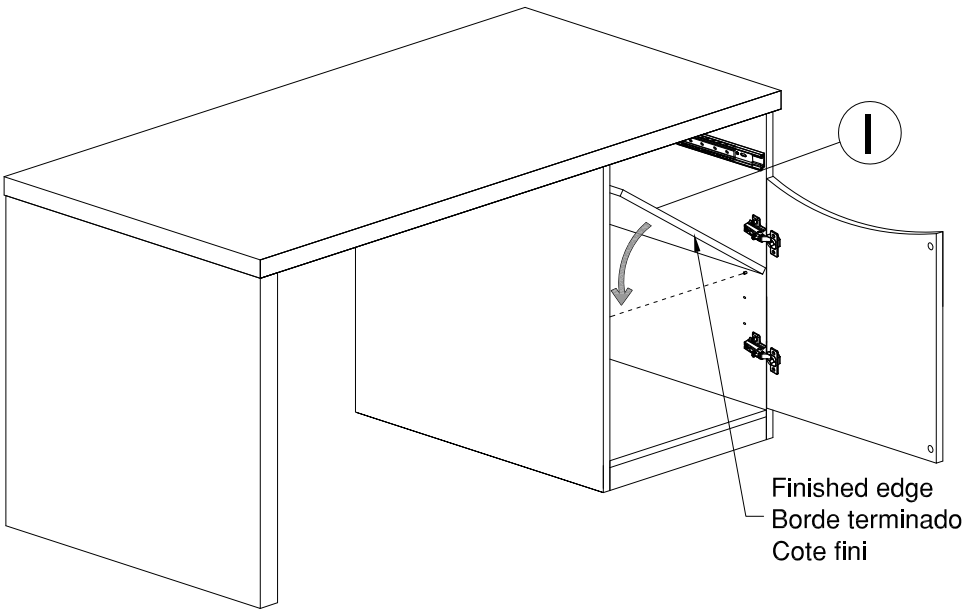
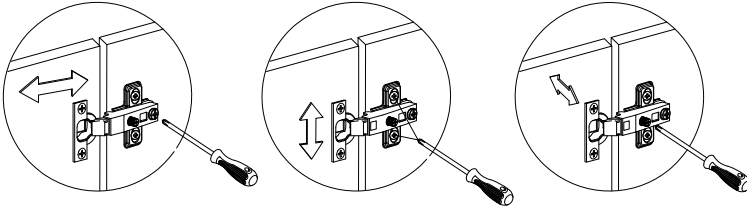

# STEP 15

H101725

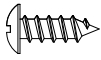

[ 6 ]

H35251

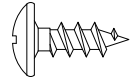

[ 4 ]

H166951

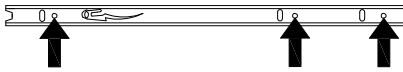

[ 2 ]

H100445

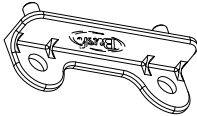

[ 2 ]

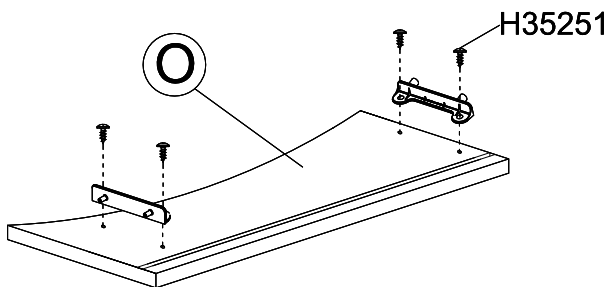
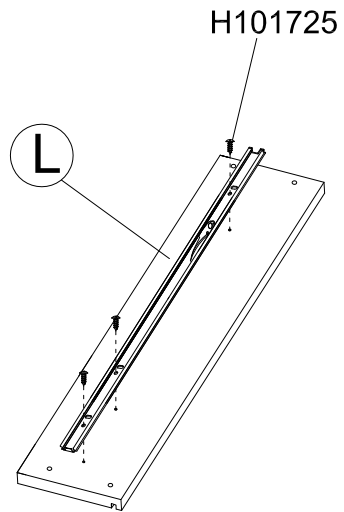
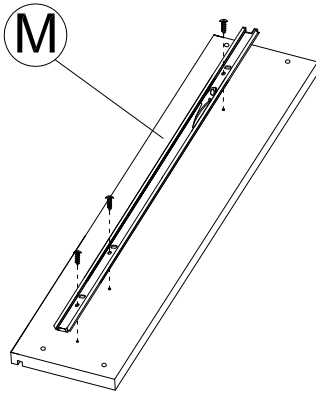

# STEP 16

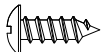
H101725  [ 4 ]

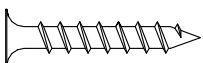
H23198  [ 4 ]

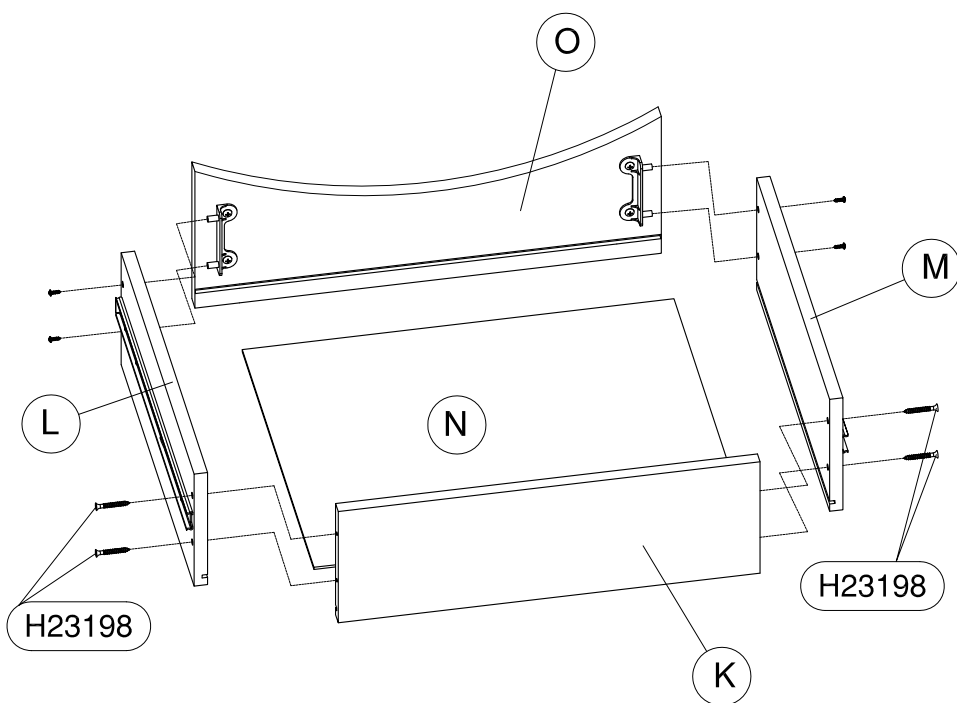

# STEP 17

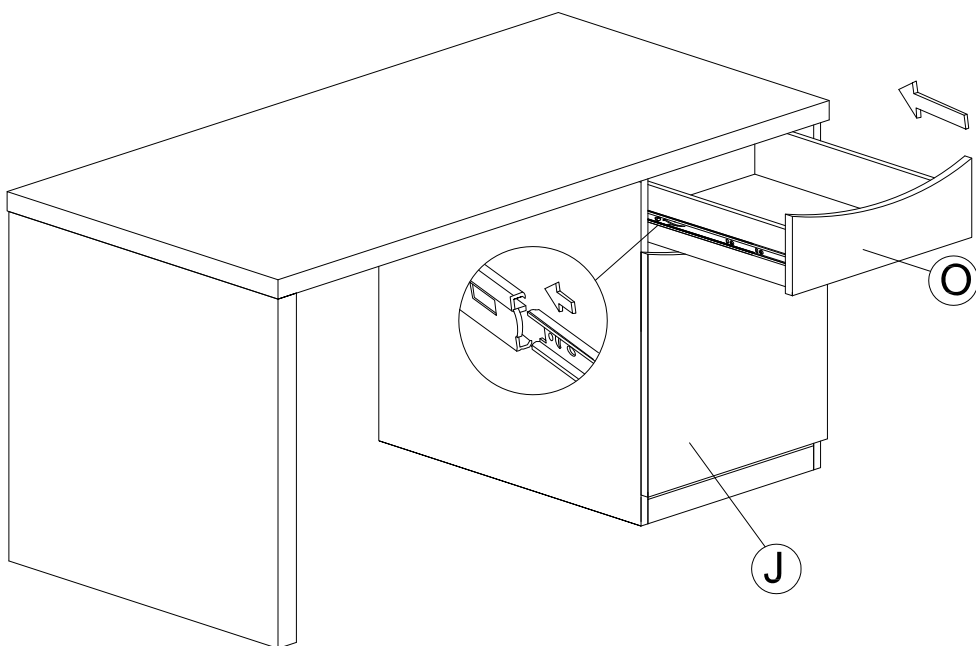

## STEP 18

- Move unit to final location.
- Coloque esta unidad en su posición permanente.
- Déplacez l'unité dans l'endroit final.

- Adjust drawer fronts as shown below.
- Ajuste la parte delantera de las gavetas según es indicado.
- Ajustez les façades de tiroir comme montré ci-dessous.

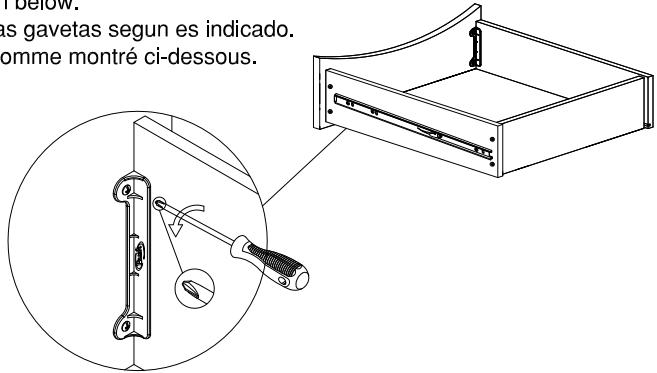

### STEP 1.

- Loosen screws on back of drawer front brackets as shown.
- Afloje los tornillos en la parte trasera de la gaveta según es indicado.
- Desserrez les vis dans les appuis en plastique sur le dos de l'avant de tiroir comme montré.

### STEP 2.

- Position drawer front as required.
- Ajuste la parte delantera de la gaveta según sea necesario.
- Placez l'avant de tiroir comme nécessaire.

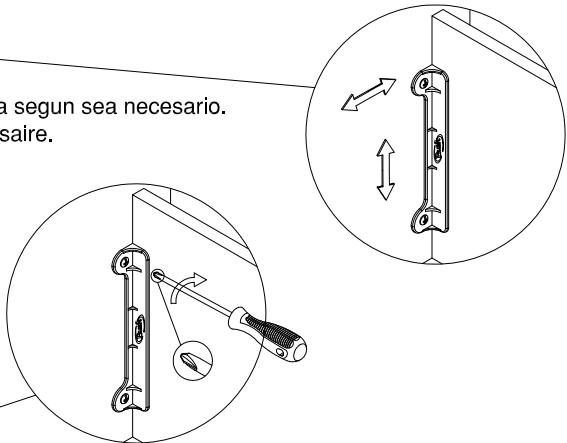

### STEP 3.

- Tighten screws while holding drawer front in position.
- Apriete los tornillos mientras sujeta la parte delantera de la gaveta en su posición permanente.
- Serrez les vis tout en tenant l'avant de tiroir en position.

# STEP 19

H101725

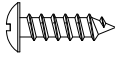

[ 2 ]

H156359

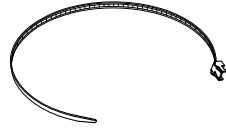

[ 2 ]

H157328



[ 2 ]

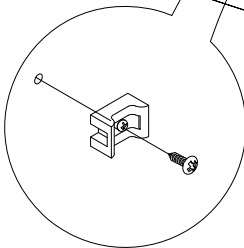
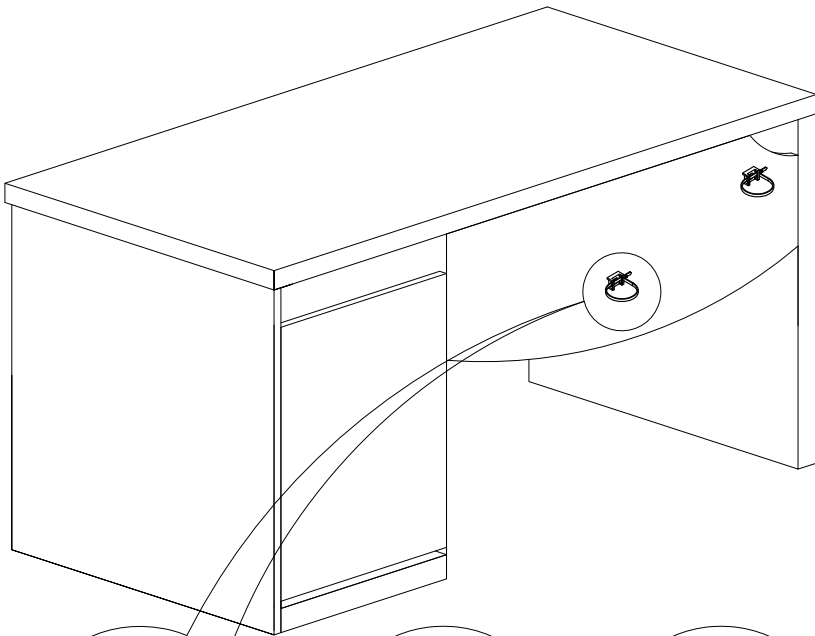

1

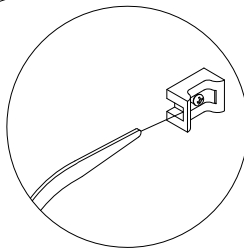

2

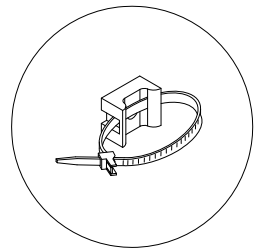

3

## STEP 20

### Maintenance Tip

It may be necessary to periodically open each drawer to its full extension. This will reset the drawer slides and allow for continued smooth operation.

### Información de Mantenimiento

Puede ser necesario el abrir cada gaveta a su máxima extensión periódicamente. Este procedimiento ayuda a recomponer las correderas de las gavetas, asegurando una operación libre.

### Conseil dentretien

Il faut de temps en temps ouvrir chaque tiroir jusqu'au bout.

Cela remboite les coulisses des tiroirs pour qu'elles continuent de fonctionner sans accroc.

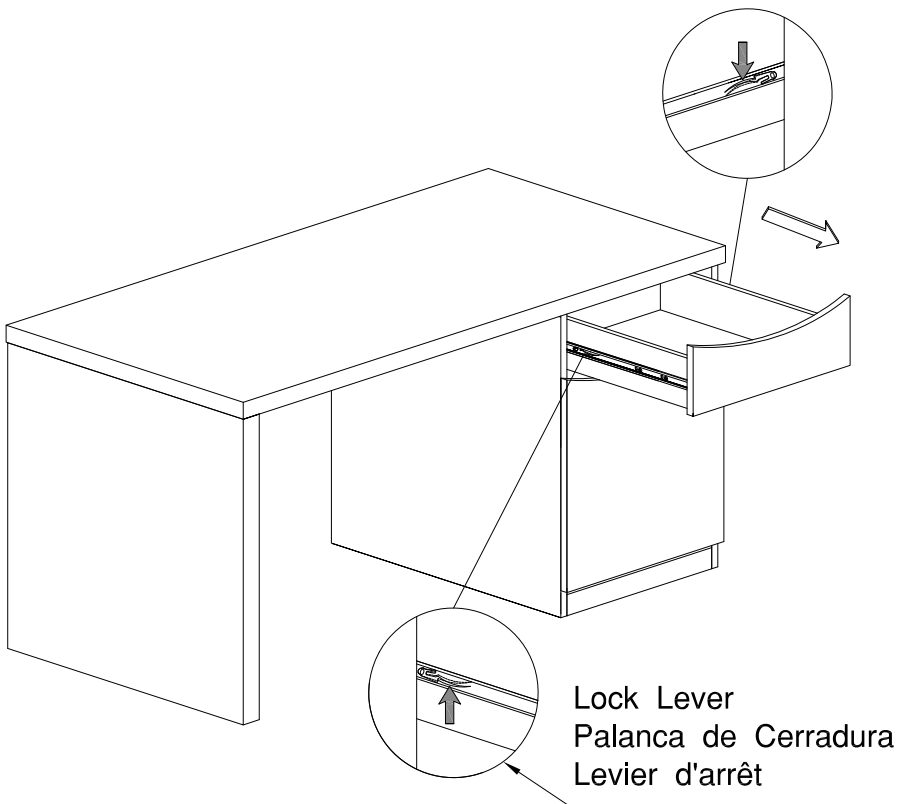

## STEP 21

Maximum Weight: 200 Lbs.  
Peso Máximo: 200 Libras  
Poids Maximum: 90.8 Kilogramme

Maximum Weight: 15 Lbs.  
Peso Máximo: 15 Libras  
Poids Maximum: 6.8 Kilogramme

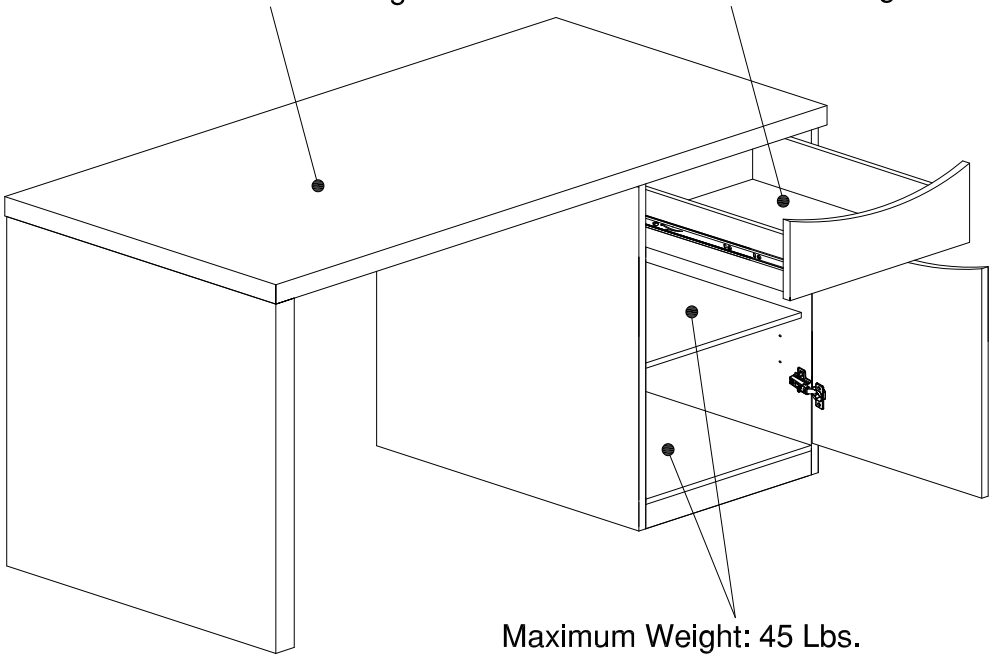

Maximum Weight: 45 Lbs.  
Peso Máximo: 45 Libras  
Poids Maximum: 20.4 Kilogramme



THIS PAGE INTENTIONALLY LEFT BLANK



# WARRANTY INFORMATION/INFORMATIONS POUR LA GARANTIE/INFORMACIÓN DE GARANTÍA

**BUSH FURNITURE'S WRITTEN WARRANTY TO YOU**  
In order to provide you with timely assistance, please thoroughly inspect your furniture for missing or defective parts immediately after opening the carton. To receive replacement or missing parts under this warranty, call our Consumer Service Department TOLL-FREE at 1-800-950-4782. Please have the Model, Part, and Lot Numbers found in the instruction manual available for your reference. You will also need your sales receipt or other proof of purchase. Replacement part(s) will be shipped to you at no charge with Bush Industries assuming all shipping and handling charges.

This Bush Furniture product is warranted to the original purchaser at the time of purchase and for a period of one year thereafter.

We warrant to you, the original purchaser, that our furniture and all its parts and components are free of defects in material or workmanship. "Defects", as used in this warranty, is defined as any imperfection which impairs the use of the furniture product.

Our warranty is expressly limited to the replacement of furniture parts and components. For one year after the date of purchase, Bush will replace any parts that are defective in material or workmanship.

This warranty applies under conditions of normal use. Our Bush Furniture products are not intended for outdoor use. This warranty does not cover: 1) defects caused by improper assembly or disassembly; 2) defects occurring after purchase due to product modification, intentional damage, accident, misuse, abuse, negligence or exposure to the elements; and 3) labor or assembly costs.

**IMPLIED WARRANTIES, INCLUDING THE WARRANTY OF MERCHANTABILITY, SHALL NOT EXTEND BEYOND THE DURATION OF THE WRITTEN WARRANTY STATED ABOVE, AND IN NO EVENT SHALL BUSH BE LIABLE FOR INCIDENTAL OR CONSEQUENTIAL DAMAGES RESULTING FROM USE OF THE PRODUCT.** Some states do not allow a limitation on how long an implied warranty lasts or the exclusion or limitation of incidental or consequential damages, so the above limitation and exclusion may not apply to you.

This warranty gives you specific legal rights. You may also have other rights that may vary from state to state.

**VOTRE GARANTIE BUSH FURNITURE**  
Afin de vous assister rapidement, veuillez inspecter votre mobilier en détail immédiatement après l'ouverture du carton en cas de pièces manquantes ou défectueuses. Pour recevoir une pièce de rechange ou manquante couverte par cette garantie, appelez notre département de service clientèle GRATUITEMENT au 1-800-950-4782. Veuillez tenir à disposition les numéros de modèle, de pièce et de lot qui se trouvent dans le manuel d'instruction pour votre référence. Vous aurez également besoin de votre reçu ou d'une autre preuve d'achat. La (les) pièce(s) de rechange vous sera (seront) envoyée(s) sans frais, Bush Industries se chargeant de tous les frais d'expédition.

Tout le produit Bush Furniture est garanti à l'acheteur original à partir de la date d'achat pour une période d'un an.

Nous vous garantissons, à vous l'acheteur original, que notre mobilier et toutes ses pièces et composants sont sans défaut de matériau ou de fabrication. Le terme "défauts" utilisé dans cette garantie, est défini comme étant toutes les imperfections qui compromettent l'utilisation du meuble.

Notre garantie est expressément limitée au remplacement des pièces et des composants du mobilier. Pendant un an après la date d'achat, Bush remplacera toute pièce défectueuse dans le matériau ou sa fabrication.

Cette garantie d'applique sous des conditions d'utilisation normale. Nos produits Bush Furniture ne sont pas destinés à être utilisés en plein air. Cette garantie ne couvre pas: 1) les défauts causés par un mauvais assemblage ou démontage, 2) les défauts ayant lieu après l'achat et dus à la modification du produit, des dommages intentionnels, des accidents, une mauvaise utilisation, un mauvais traitement, la négligence ou l'exposition aux éléments, et 3) les frais de main d'œuvre ou d'assemblage.

**LES GARANTIES TACITES, Y COMPRIS LA GARANTIE DE QUALITE MARCHANDE, NE S'ETENDRONT PAS AU-DELA DE LA DUREE ECRITE CITEE CI-DESSUS, ET BUSH NE SERA EN AUCUN CAS RESPONSABLE DES DOMMAGES ACCESSOIRES OU INDIRECTS RESULTANT DE L'UTILISATION DU PRODUIT.** Certains états ne permettent pas d'appliquer une limite à la durée de la garantie tacite, ni une exclusion ou limitation des dommages accessoires ou indirects; dans ce cas les limitations ou exclusion ci-dessus peuvent ne pas s'appliquer à vous.

Cette garantie vous donne des droits légaux spécifiques. Il se peut que vous ayez également d'autres droits qui peuvent varier d'un état à l'autre.

Garantía Escrita de Bush Furniture para usted  
Para brindarle asistencia oportuna, por favor, verifique detalladamente que a su mueble no le falte o tenga piezas defectuosas inmediatamente después de abrir la caja. Para recibir un reemplazo o la parte faltante bajo esta garantía, llame a nuestro Departamento de Servicio al Consumidor GRATIS al 1-800-950-4782. Sírvase traer los números de modelo, parte y lote que se encuentran en el manual de instrucciones disponible para su referencia. Además, necesitará el recibo de su compra u otra prueba de compra. La(s) pieza(s) de reemplazo le será(n) enviada(s) sin cargo por Bush Industries asumiendo los gastos de envío y manipuleo.

Todo mueble de Bush Furniture es garantizado al comprador original al momento de la compra y por un periodo de un año en adelante.

Le garantizamos a usted, el comprador original, que nuestros muebles sus partes y componentes están libres de defectos en materiales o trabajo. "Defectos", según se usa en esta garantía, se define como una imperfección que perjudica el uso del producto mobiliario.

Nuestra garantía se limita expresamente al reemplazo de partes y componentes mobiliarios. Durante un año después de la fecha de compra, Bush reemplazará cualquier parte defectuosa en material o trabajo.

Esta garantía se aplica bajo condiciones de uso normal. Nuestros productos de Bush Furniture no son para uso en exteriores. Esta garantía no cubre: 1) defectos causados por un ensamblaje o desensamblaje inadecuado; 2) defectos que ocurran después de la compra debido a modificación del producto, daño intencional, accidente, mal uso, abuso, negligencia o exposición a los elementos; y 3) costos de trabajo o ensamblaje.

**LAS GARANTÍAS IMPLICADAS, INCLUYENDO LA GARANTÍA DE COMERCIABILIDAD, NO SE EXTENDERÁN MÁS ALLÁ DE LA DURACIÓN DE LA GARANTÍA ESCRITA MENCIONADA, Y EN NINGÚN CASO BUSH SERÁ RESPONSABLE POR DAÑOS INCIDENTALES O CONSIGUIENTES COMO RESULTADO DEL USO DEL PRODUCTO.** Algunos estados no permiten una limitación sobre el tiempo de duración de la garantía implícada o la exclusión o limitación de daños incidentales o consiguientes, de manera que la limitación y exclusión mencionadas pueden no aplicarse para usted.

Esta garantía le otorga derechos legales específicos. Puede también tener otros derechos que pueden variar según los estados.

## PLEASE RETAIN THIS FOR YOUR RECORDS / VEUILLEZ CONSERVER CECI POUR VOS ARCHIVES POR FAVOR CONSERVE ESTE DOCUMENTO PARA SUS REGISTROS

You may need to refer to this information in case of warranty claim for insurance purposes.  
Il se peut que vous ayez besoin de ces informations en cas de réclamation de garantie pour votre assurance.  
Puede necesitar referirse a esta información, en caso de algún reclamo de la garantía con fines relacionados al seguro.

Date Purchased/Date d'achat/Fecha de la Compra: \_\_\_\_\_

Store Name/Nom du magasin/Nombre de la Tienda: \_\_\_\_\_

Model #/Modèle #/Modelo #: \_\_\_\_\_

Product Description/Description du produit/Descripción del Producto: \_\_\_\_\_

Lot Code: \_\_\_\_\_