

MODEL EX45670



Can we help you ?

THE Bush Furniture

Difference

- QUALITY
- INNOVATION
- SERVICE
- VALUE

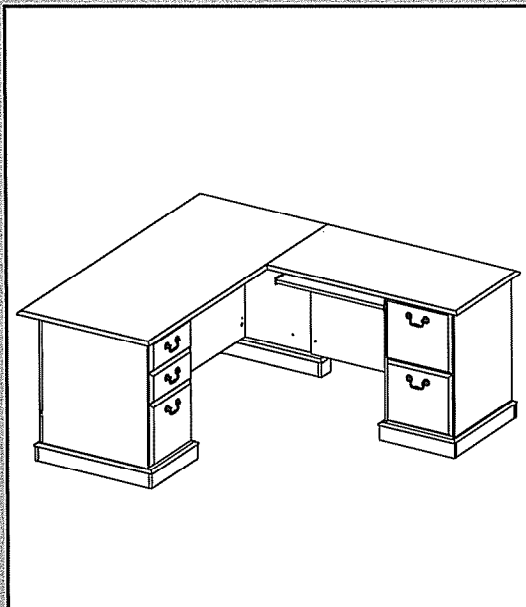

A166351



Thank you for purchasing this Bush Furniture product. We trust that you will be completely satisfied with your product for many years to come. Bush Furniture products are backed by a 10-year warranty and crafted with today's styles in mind for the way you work. Do not return product to store - contact us first at 1-800-950-4782.

Merci d'avoir acheté ce produit Bush Furniture. Nous sommes sûr que vous serez complètement satisfait de votre meuble pendant de nombreuses années. Les produits Bush Furniture sont garantis pendant 10 an et sont conçus dans les styles actuels tout en gardant à l'esprit votre façon de travailler. Ne renvoyez pas le produit au magasin, contactez-nous d'abord au 1-800-950-4782.

Gracias por comprar este producto de Bush Furniture. Confiamos que usted estará completamente satisfecho con su mueble por muchos años. Los productos de Bush Furniture tienen 10 años de garantía y son diseñados con los estilos de hoy en mente para la manera que usted vive. No devuelva el producto a la tienda, primero comuníquese con nosotros al 1-800-950-4782.





IT'S AS EASY AS 1,2,3

Assembly tips:

1. Read the instructions and become familiar with the parts.
2. Ensure this carton contains all parts, fasteners and hardware.
3. To protect floors, assemble the furniture on the carton.
4. An assistant may be helpful.
5. Use of power tools is not recommended.

Conseils d'assemblage:

1. Lisez les instructions et familiarisez-vous avec les pièces.
2. Assurez-vous que le carton contient toutes les pièces, toutes les pièces de fixation et toute la quincaillerie.
3. Pour protéger vos sols, assemblez le meuble sur le carton.
4. Il peut être utile de vous faire aider.
5. L'utilisation d'outils électriques n'est pas recommandée.

Consejos de Ensamblaje:

1. Lea las instrucciones y familiarícese con las partes.
2. Asegúrese de que esta caja contenga todas las piezas, los sujetadores y el equipo.
3. Para proteger el piso, ensamble el mueble en el carton.
4. Un asistente puede serle útil.
5. El uso de herramientas eléctricas no se recomienda.



M - F 8:30 a.m. - 7:30 p.m. ET
(Except Holidays)

Bush Consumer Services
One Mason Drive
Jamestown, NY 14701
ConsumerService@BushIndustries.com

1-800-950-4782 USA/CANADA
1-800-950-4782 MEXICO
Se habla español
Outside USA/CANADA/MEXICO
001-716-665-2510 Ext. 5900



www.bushfurniture.com/workplacesolutions

CONSUMER SERVICE YOU CAN DEPEND ON

Questions? Operators are standing by at our TOLL-FREE help line to assist you with assembly; and, if necessary, to quickly replace damaged/missing parts. Assistance is available 5 days a week. Simply have your store receipt, instruction manual, and part number/description ready when you call our TOLL -FREE help line. It's that easy.

UN SERVICE CLIENTELE SUR LEQUEL VOUS POUVEZ COMPTER
Des questions? Des opérateurs sont prêts sur notre ligne d'assistance GRATUITE pour vous aider à l'assemblage et, si nécessaire, remplacer rapidement les pièces endommagées/manquantes. L'assistance est disponible 5 jours par semaine. Ayez simplement votre reçu de magasin, votre manuel d'instruction et le numéro de pièces/description à votre disposition lorsque vous appelez notre ligne d'assistance GRATUITE. C'est aussi simple que ça.

SERVICIO AL CONSUMIDOR CON EL QUE PUEDE CONTAR
¿Preguntas? Los operadores están listos para ayudarlo con el ensamble a través de una línea de ayuda GRATUITA, y en caso de ser necesario, reemplazar de inmediato las piezas dañadas o faltantes. La asistencia está disponible los 5 días de la semana. Solamente tenga listos su recibo de compra, manual de indicaciones y número/descripción de la pieza al momento de llamarnos a la línea de ayuda GRATUITA, Es así de sencillo.

IMPORTANT SAFETY INFORMATION



WARNING

This product is designed and intended for use with computer, fax, and printer equipment only. Improper loading with television or other heavy equipment could cause instability, tip over, and/or serious injury.

Este producto esta diseñado solamente para el uso con computadores, faxes, e impresoras. Inapropiado uso al poner televisores u otro equipo pesado puede causar inestabilidad, rodamiento, y/o herida (golpes) serios.

Ce produit est uniquement conçu pour une utilisation avec un ordinateur, un télécopieur, ou une imprimante. Un chargement incorrect avec une télévision ou autre matériel lourd peut le rendre instable ou le renverser, et peut vous causer des endommagements sérieux.



WARNING

Do not move unit when loaded. Doing so could cause instability, product collapse, tip over, and/or serious injury.

No mueva la unidad cuando esté cargada. Hacerlo puede causar inestabilidad, que el producto se derrumbe, que se la caiga encima y/o heridas (golpes) serias.

Ne pas déplacer l'unité lorsqu'elle est chargée. Faire ainsi peut causer l'instabilité, l'effondrement ou le renversement du meuble et/ou des endommagements sérieux.

EXPLODED VIEW

A [1]	W153443	K [1]	W153453	U [2]	W153463
B [1]	W153444	L [1]	W153454	V [1]	W153464
C [1]	W153445	M [3]	W153455	W [1]	W153465
D [1]	W153446	N [1]	W153456	X [1]	W153466
E [1]	W153447	O [3]	W153457	Y [1]	W153467
F [4]	W153448	P [6]	W153458	Z [1]	S153468
G [4]	W153449	Q [3]	W153459	AA [1]	W153469
H [2]	W153450	R [2]	W153460	BB [1]	W153470
I [1]	W153451	S [4]	W153461	CC [2]	W153471
J [1]	W153452	T [2]	W153462		

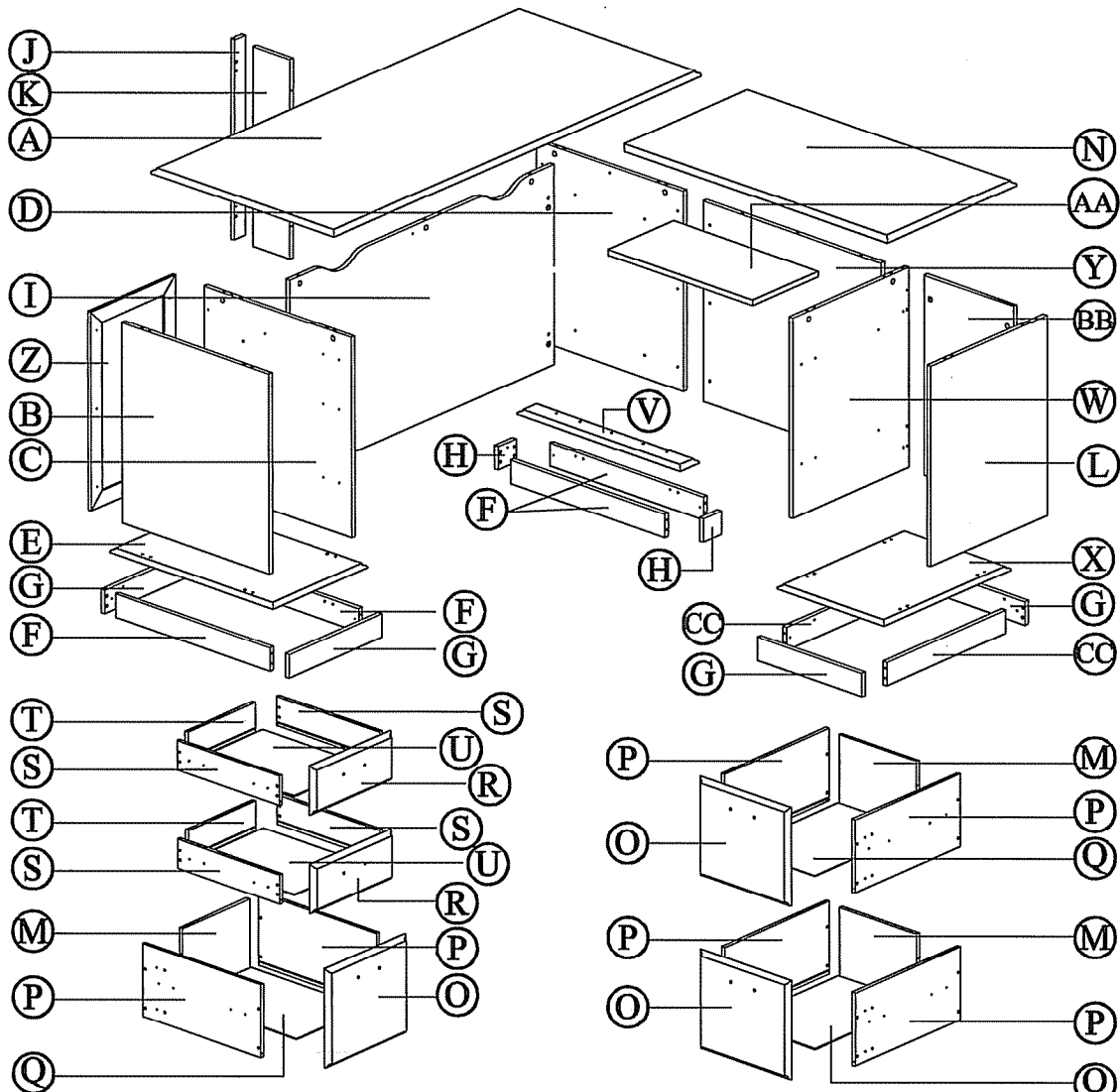
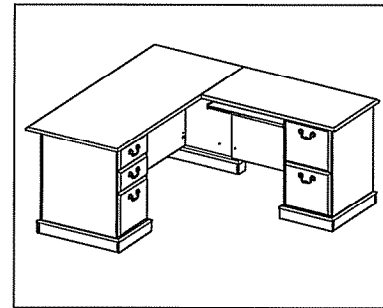

1 - 800 - 950 - 4782

A166351

FASTENERS

Fasteners are shown in actual size.

Los fijadores son demostrados en su tamaño actual.

Les attaches sont montrées dans l'échelle grandeur.

H153244

Quantity
52



8 x 30mm

H156821

Quantity
20



#10 x 1-1/4"

H158560

Quantity
3

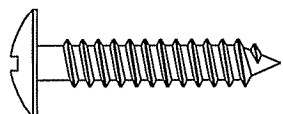

#10 x 1"

H156824

Quantity
60

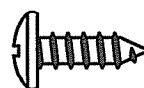

#6 x 1/2"

H156823

Quantity
72

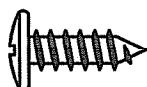

#8 x 1/2"

H158559

Quantity
10

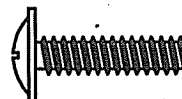

M4 x 16mm

H156849

Quantity
20

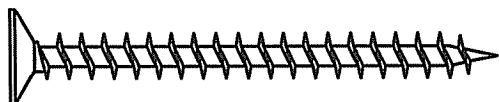

#10 x 2"

H159917

Quantity
21

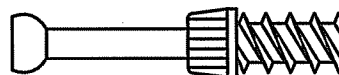

H156825

Quantity
24



#6 x 1/2"

H159916

Quantity
21

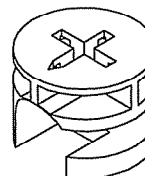

FASTENERS

Fasteners are shown in actual size.

Los fijadores son demostados en su tamaño actual.

Les attaches sont montrées dans l'échelle grandeur.

H157125

Quantity
19

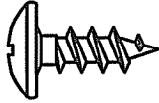

#10 x 1/2"

H157985

Quantity
11

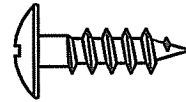

#10 x 5/8"

HARDWARE

H158961

Quantity
6

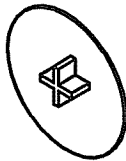

H150085

Quantity
5

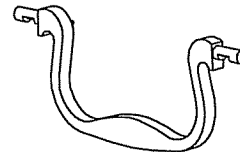

H150086

Quantity
10



H39922

Quantity
1

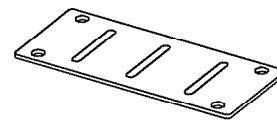

H158981

Quantity
1

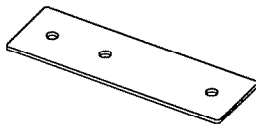

H100446

Quantity
6

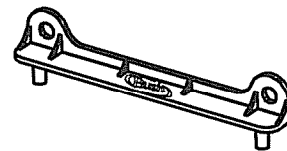

HARDWARE

H27145

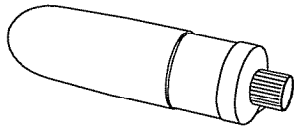

Quantity
2

H156829



Quantity
12

H156830

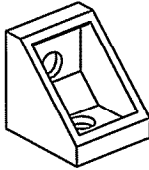

Quantity
36

H100444

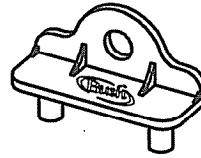

Quantity
4

H158031

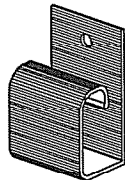

Quantity
3

Z92807

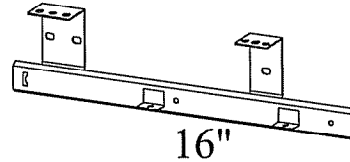

Quantity
1

Z92806

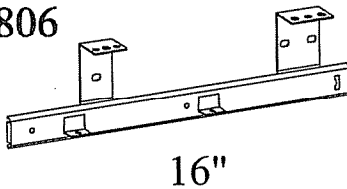

Quantity
1

Z89898

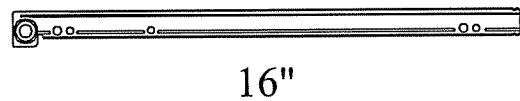

Quantity
2

Z89899

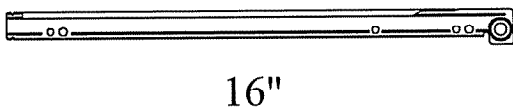

Quantity
2

Z89900

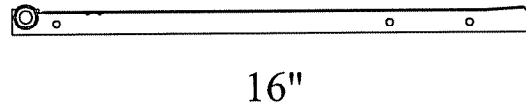

Quantity
2

Z89901

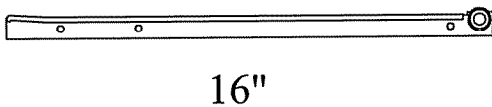

Quantity
2

Z38723

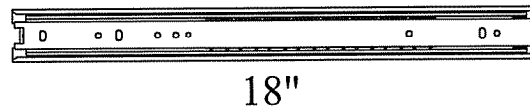

Quantity
6

HARDWARE

H153477

Quantity
6



480mm

H89793

Quantity
3



310mm

H153475

Quantity
3



308mm

Common assembly techniques.
Técnica común de ensamblaje.
Techniques communes d'assemblage.

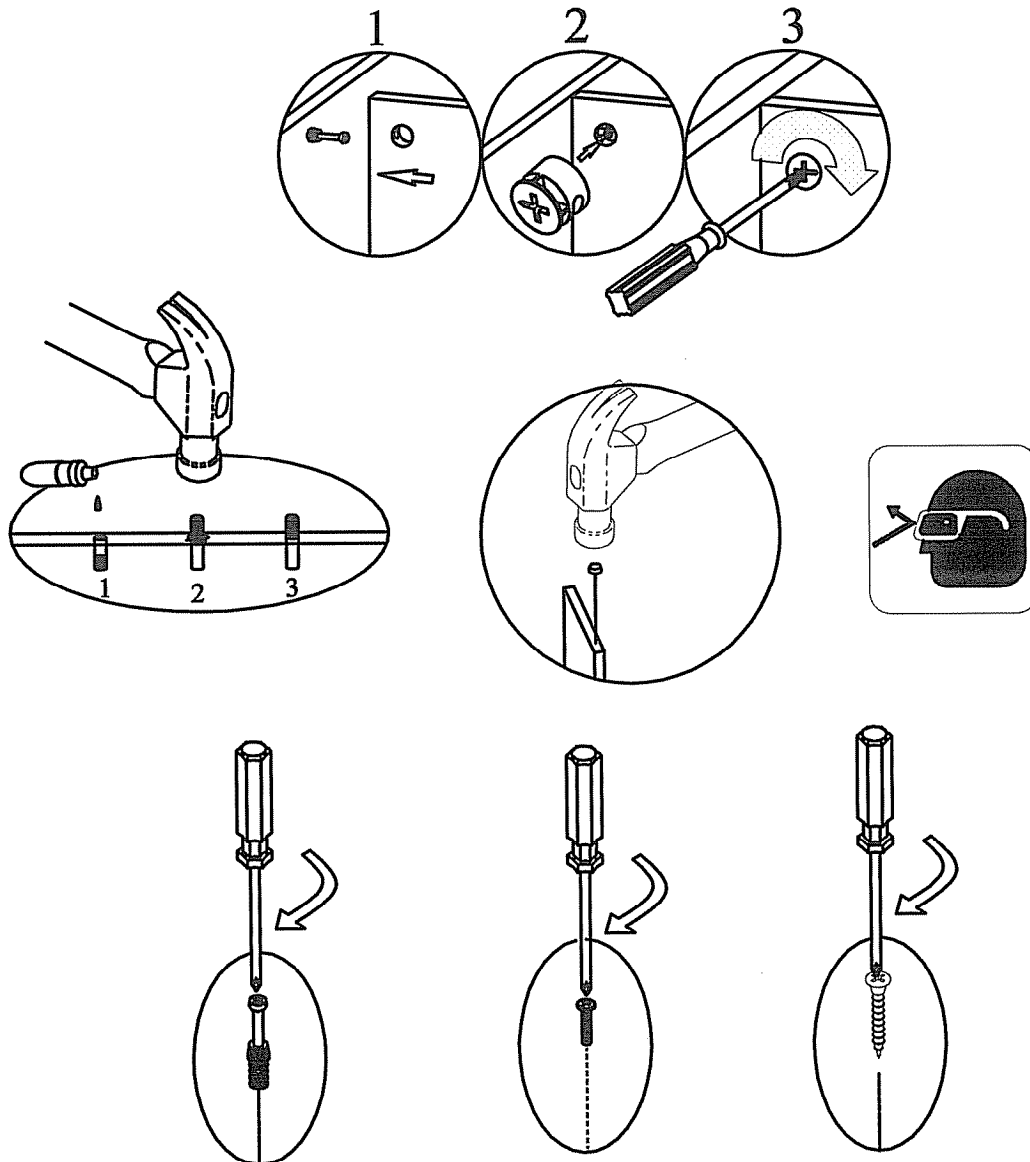

STEP 1

H153244  [8]

H156823  [12]

H156830  [12]

H27145 

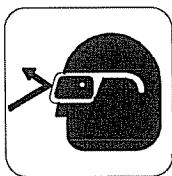
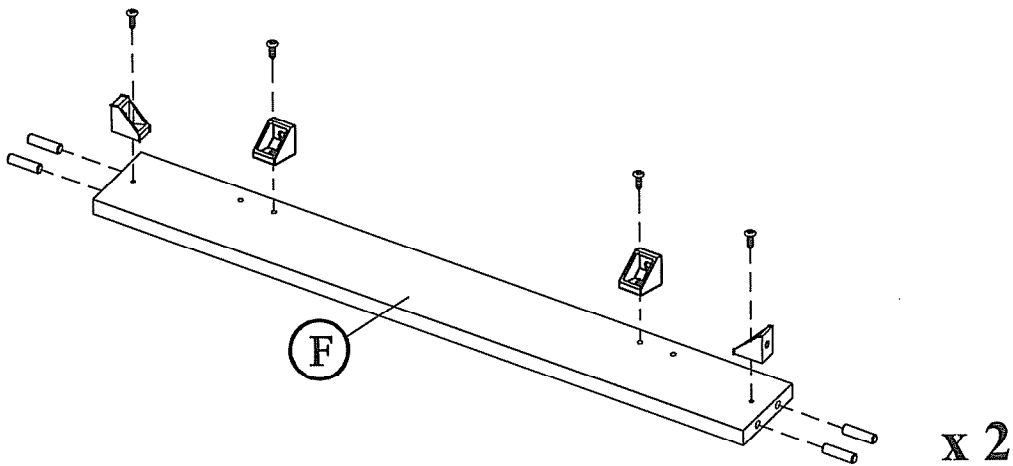
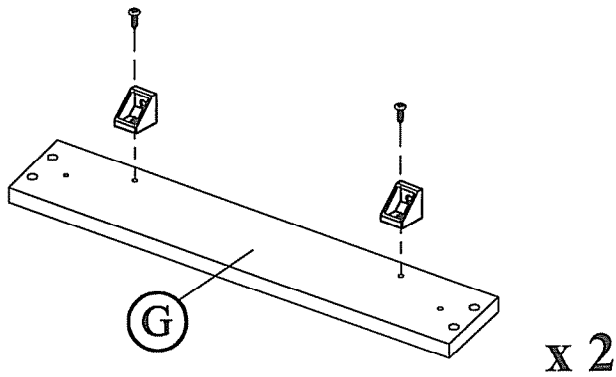

1 - 800 - 950 - 4782

A166351

STEP 2

H156829



[4]

H156823

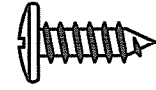

[12]

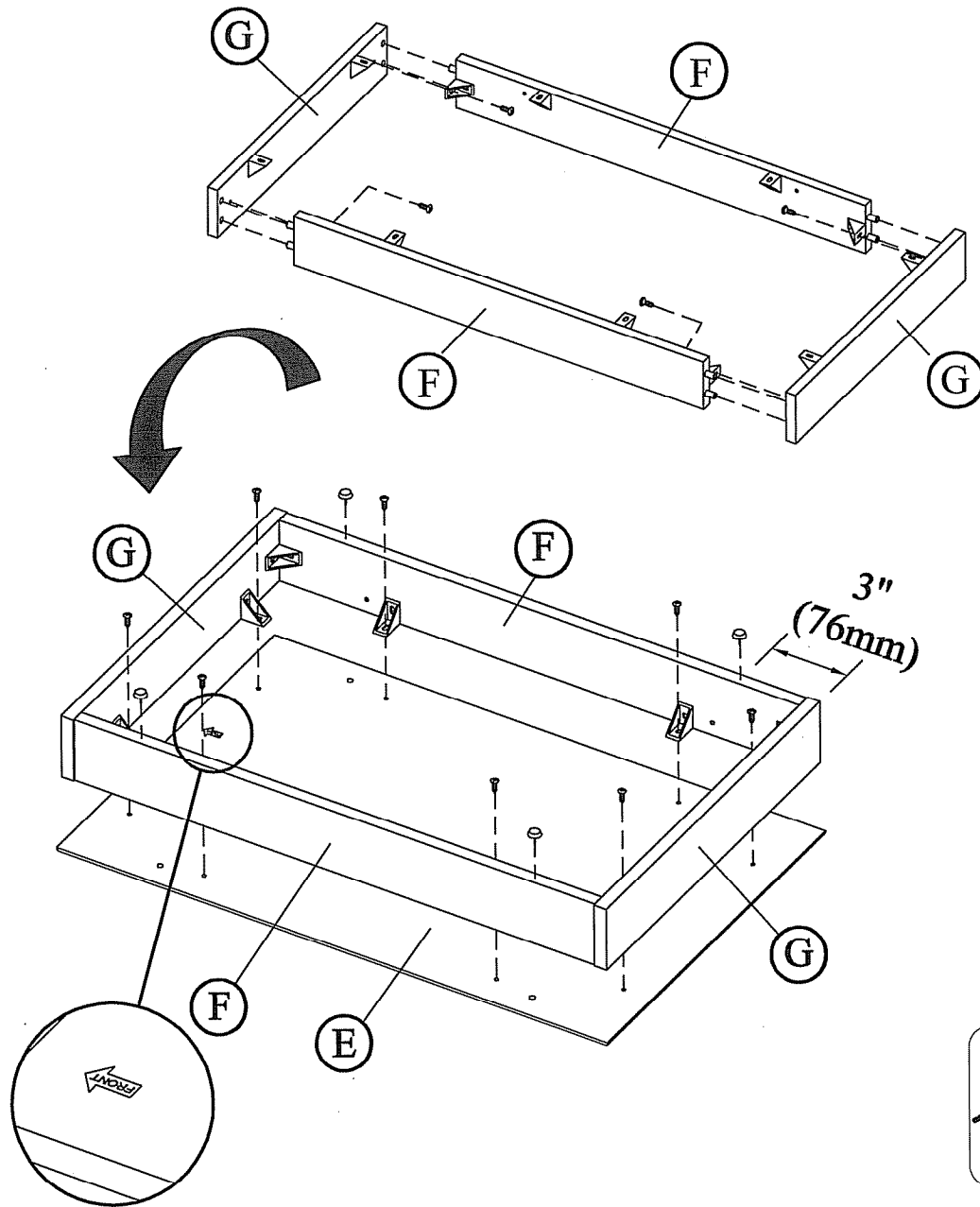

1 - 800 - 950 - 4782

A166351

STEP 3

H153244  [8]

H156823  [6]

H156830  [6]

H27145 

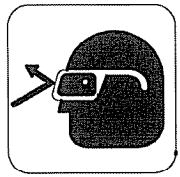
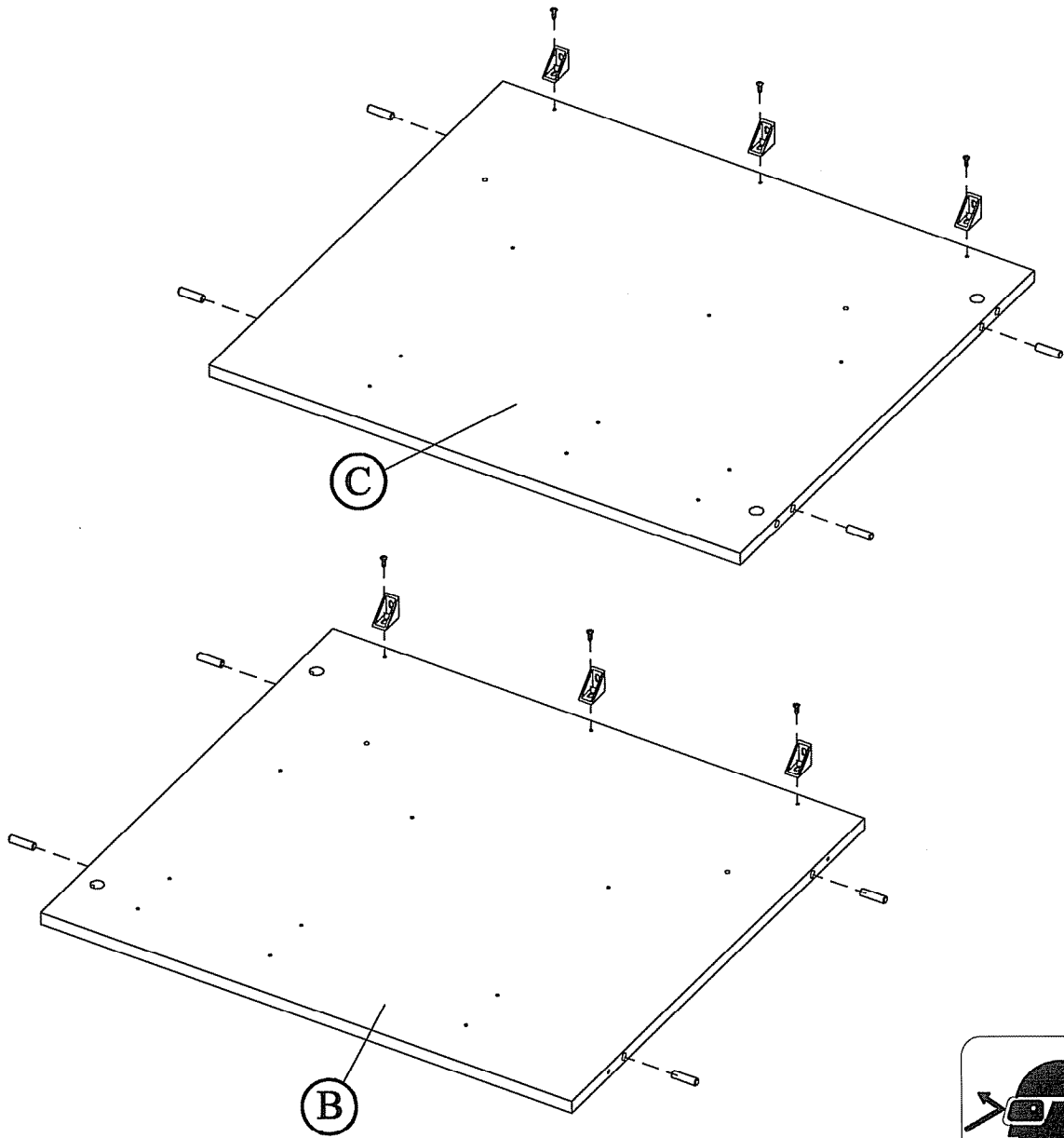

1 - 800 - 950 - 4782

A166351

STEP 4

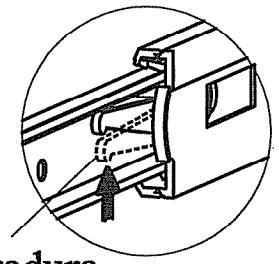
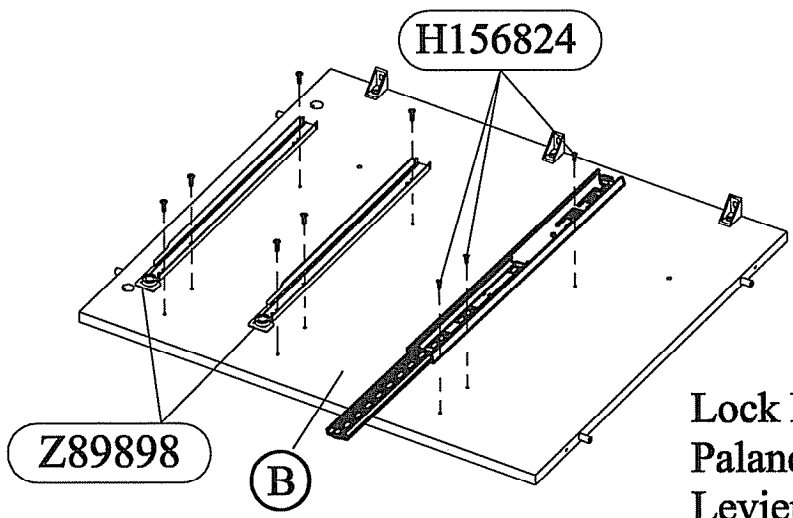
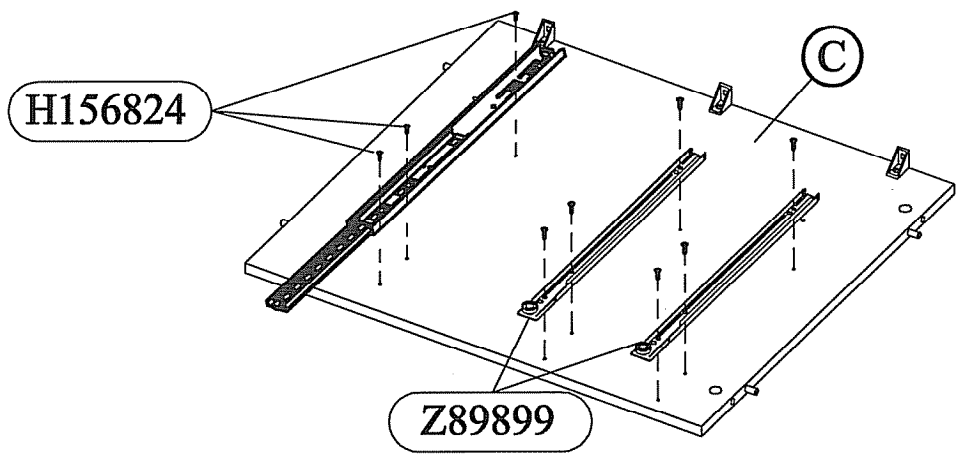
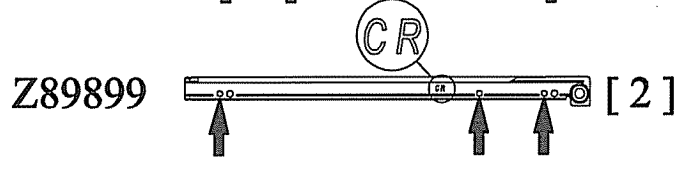
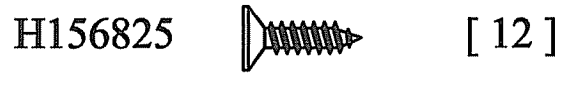
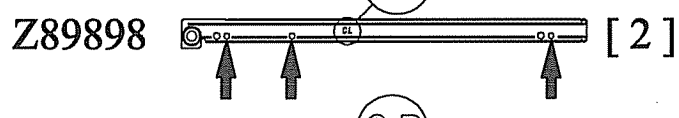
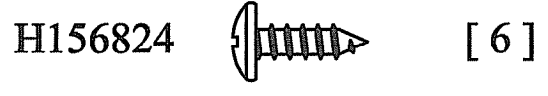
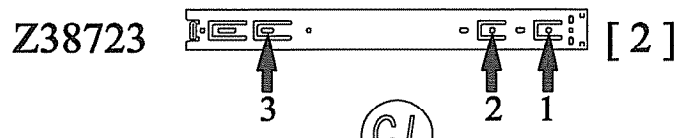

Lock Lever
 Palanca de Cerradura
 Levier d'arrêt

Move lock lever on the drawer runner as shown and separate drawer runner from drawer slide.
 Mueva Palanca de la Cerradura en la corredera como se muestra y separe la corredera del deslizable.
 Relever le Levier d'arrêt sur la coulisse pour tiror et séparez le coulisseau de la coulisse tel que montré.

1 - 800 - 950 - 4782

A166351

STEP 5

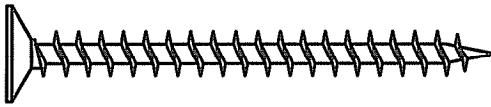
H156849  [4]

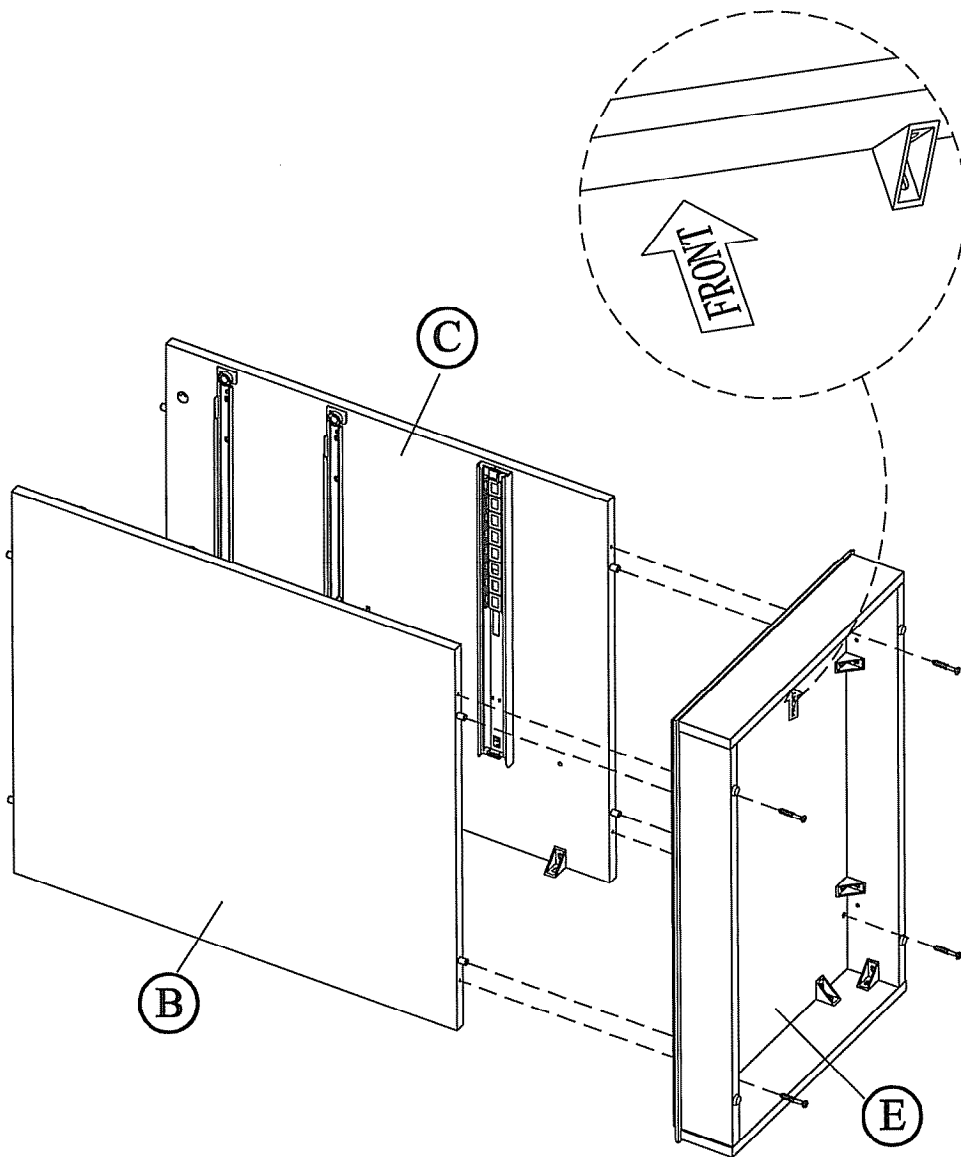

An assistant is required.
Es necesario un ayudante.
Un assistant est nécessaire.

 1 - 800 - 950 - 4782

A166351

STEP 6

H156823

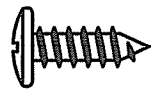

[6]

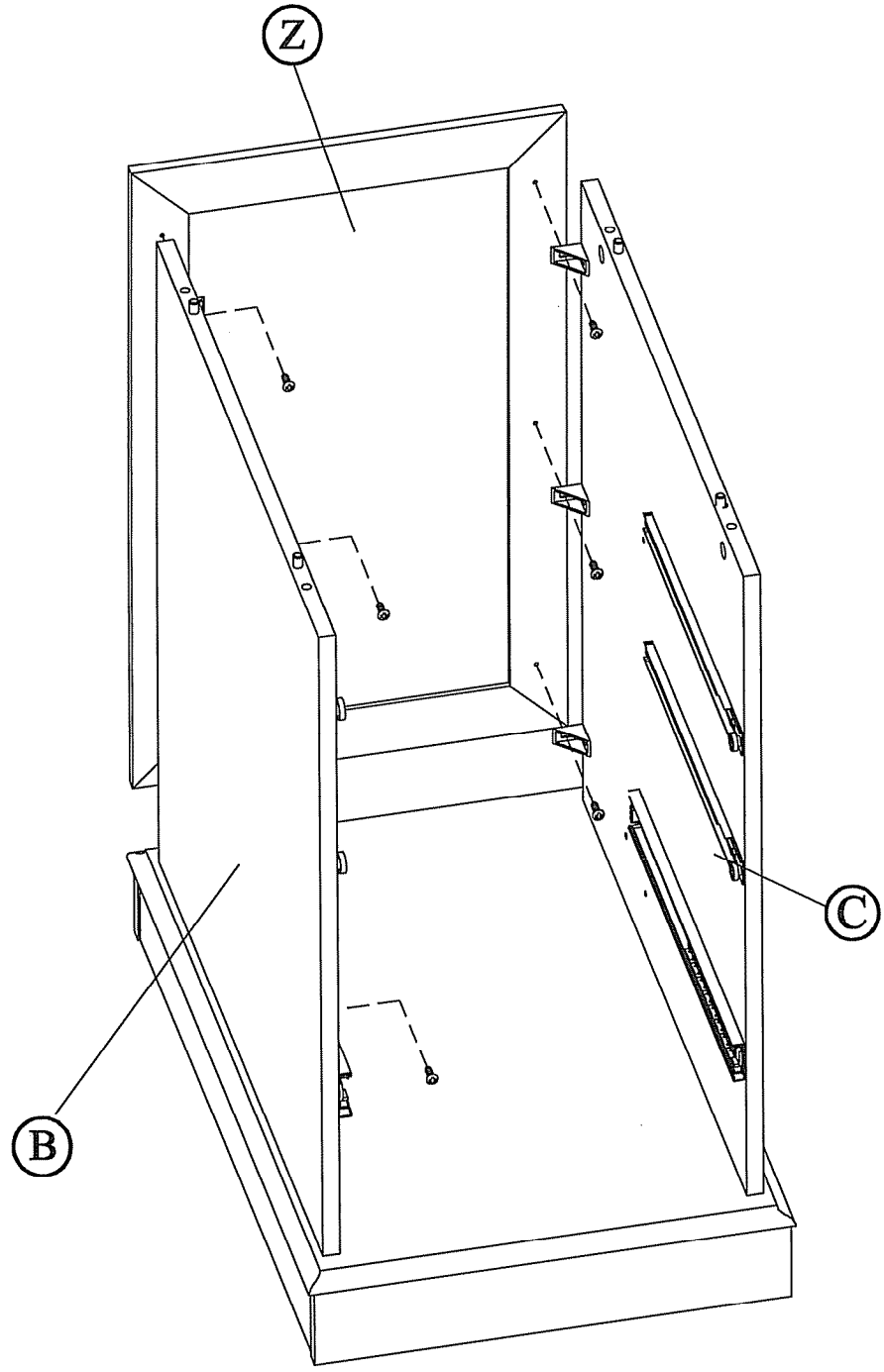



1 - 800 - 950 - 4782

A166351

STEP 7

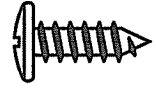
H153244  [8]

H156823  [12]

H156830  [12]

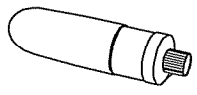
H27145 

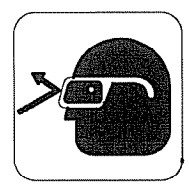
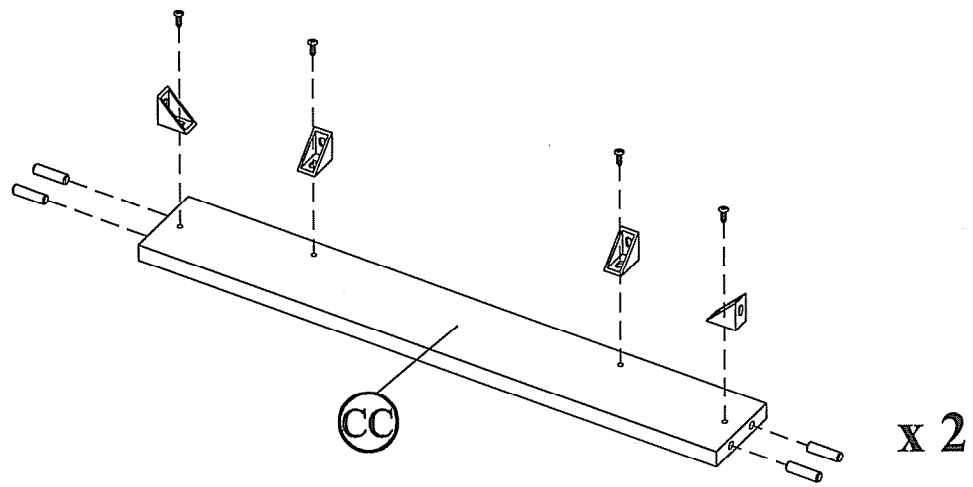
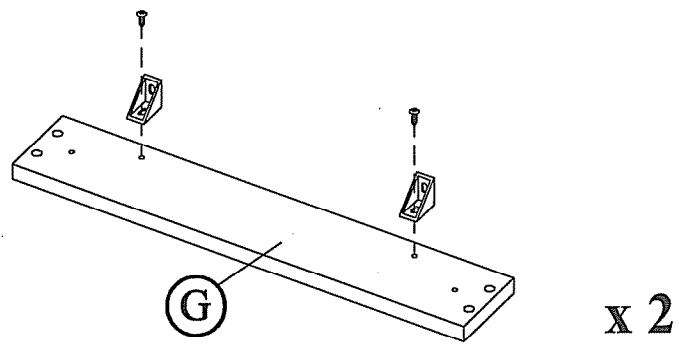

7 1 - 800 - 950 - 4782

A166351

STEP 8

H156829



[4]

H156823

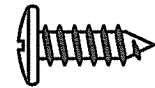

[12]

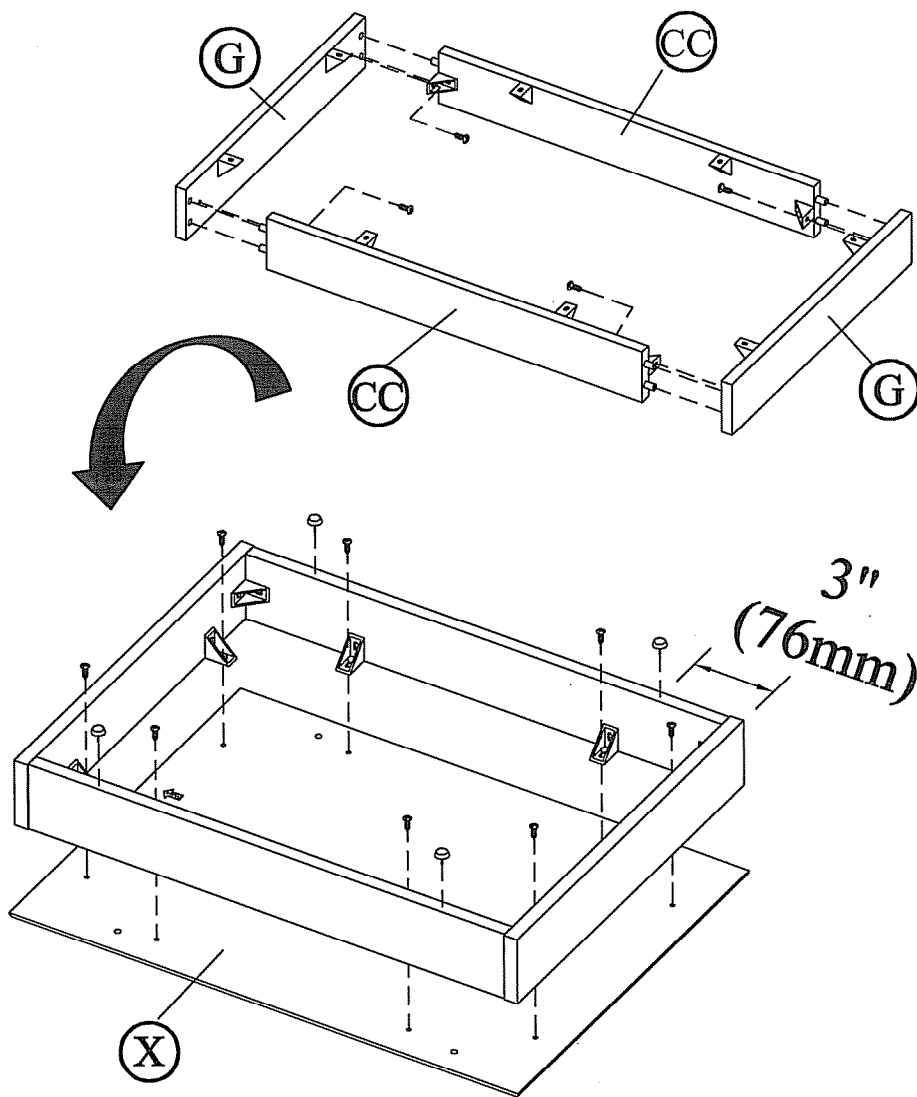

1 - 800 - 950 - 4782

A166351

STEP 9

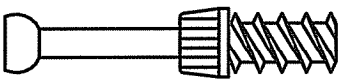
H159917  [4] H153244  [8]

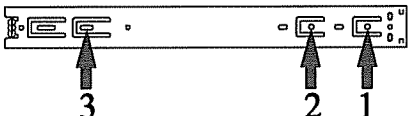
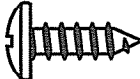
Z38723  [4] H156824  [12]

H27145 

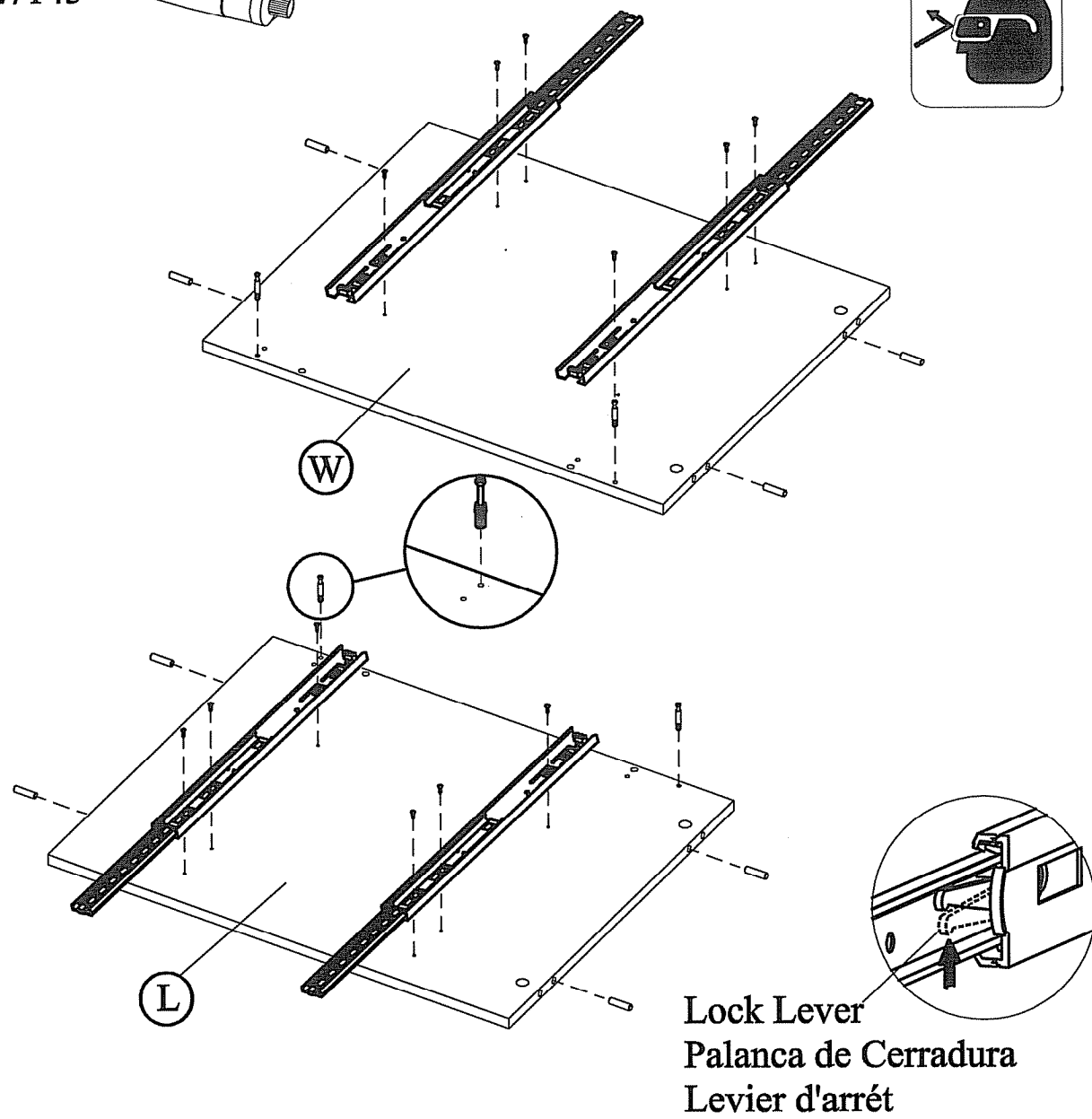
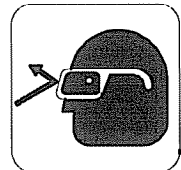

Move lock lever on the drawer runner as shown and separate drawer runner from drawer slide.
Mueva Palanca de la Cerradura en la corredera como se muestra y separe la corredera del deslizable.
Relever le Levier d'arrêt sur la coulisse pour tiror et séparez le coulisseau de la coulisse tel que montré.

 1 - 800 - 950 - 4782

A166351

STEP 10

H153244  [4]

H27145 

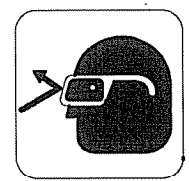
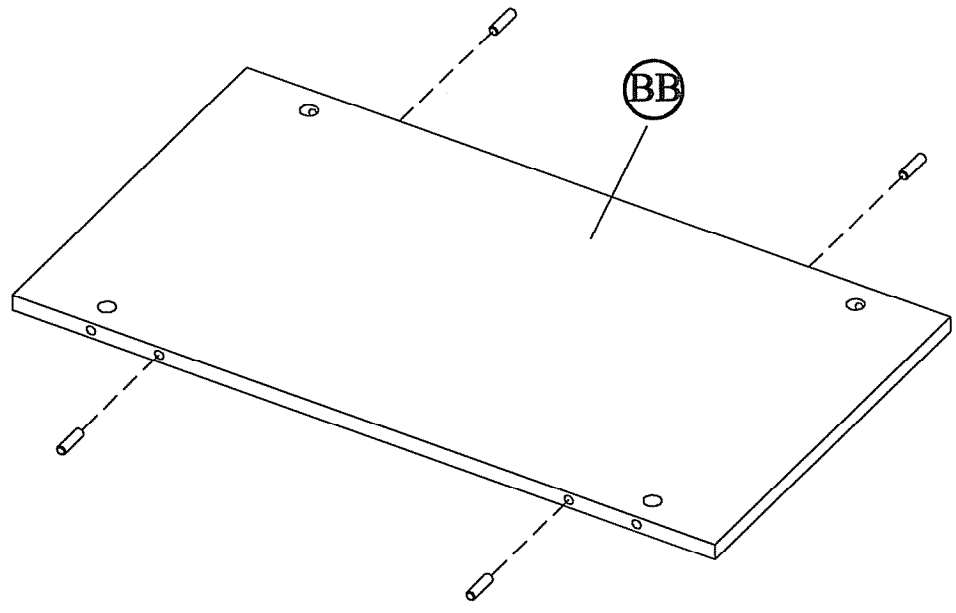

 1 - 800 - 950 - 4782

A166351

STEP 11

H159916

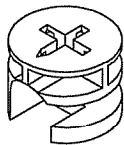

[2]

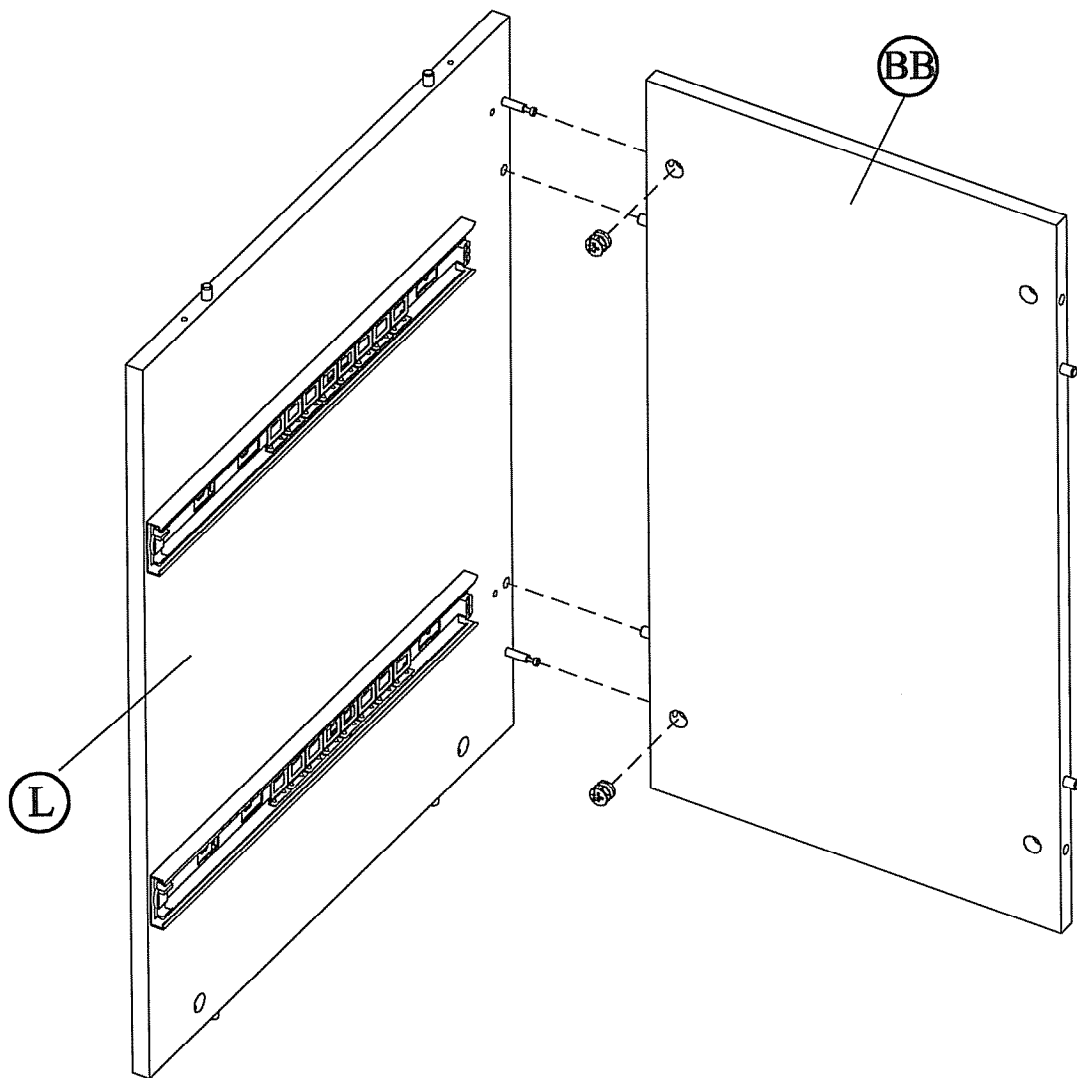

1 - 800 - 950 - 4782

A166351

STEP 12

H159916

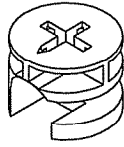

[2]

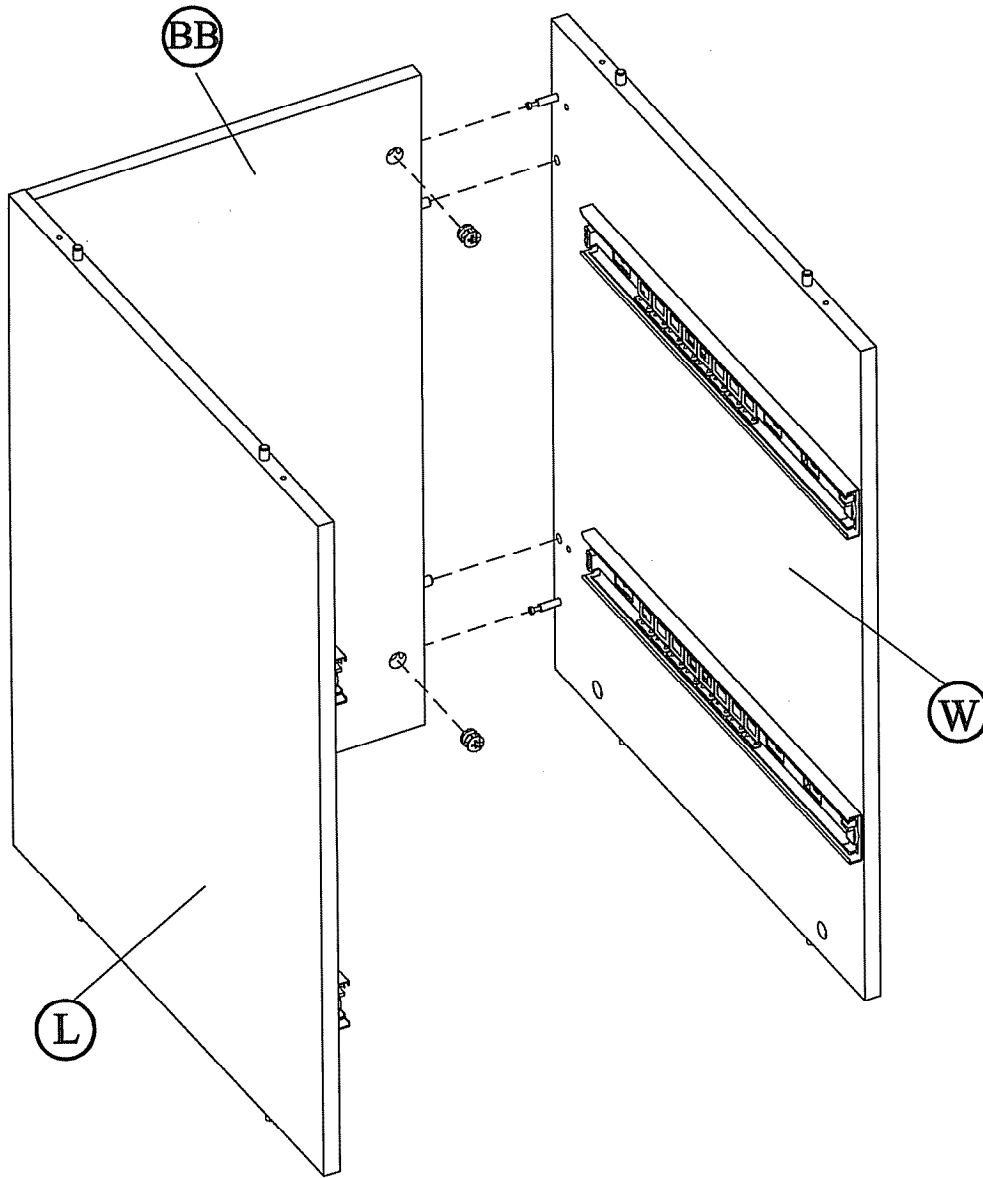

1 - 800 - 950 - 4782

A166351

STEP 13

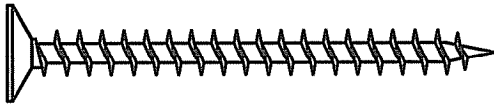
H156849  [4]

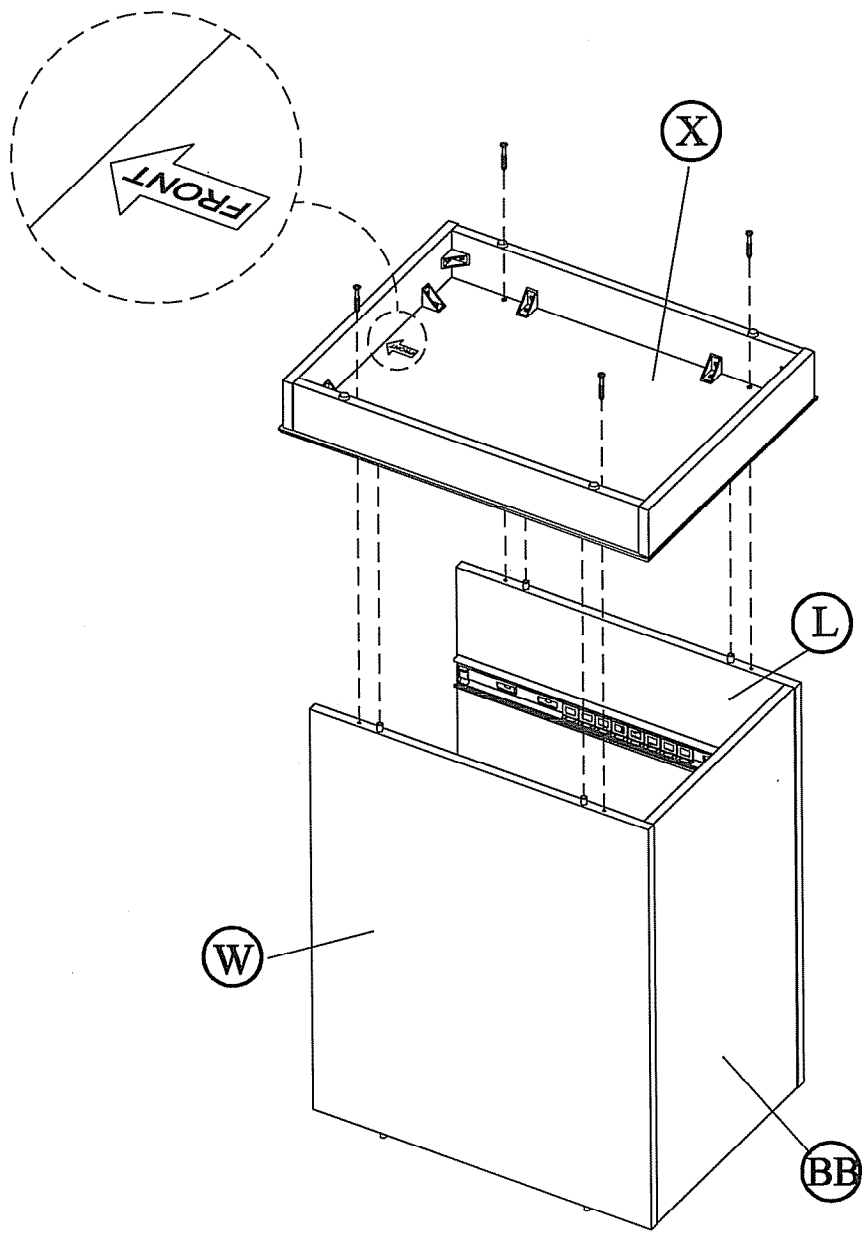



1 - 800 - 950 - 4782

A166351

STEP 14

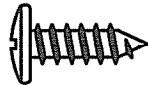
H153244  [8]

H156823  [6]

H156830  [6]

H27145 

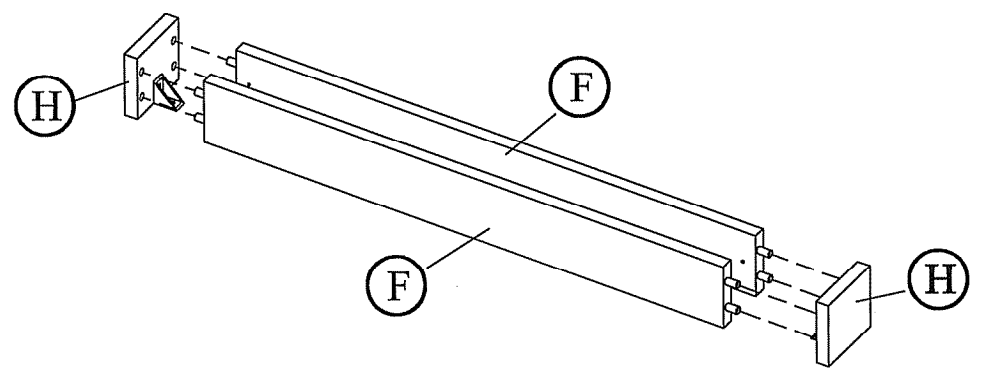
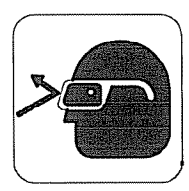
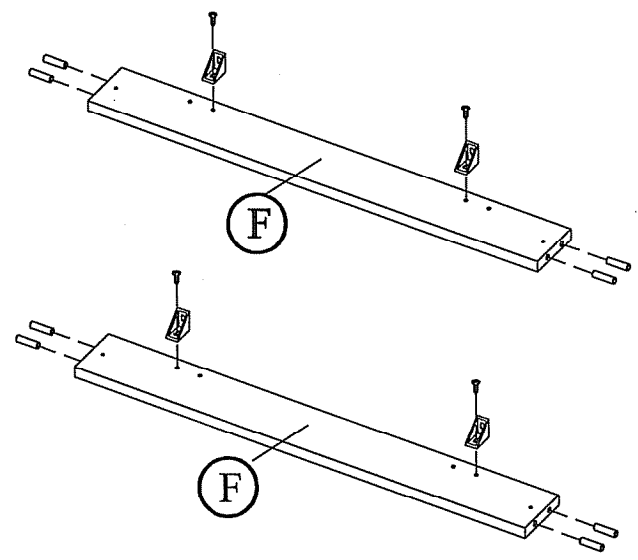
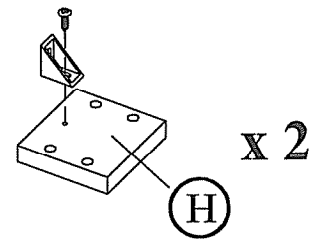

1 - 800 - 950 - 4782

A166351

STEP 15

H156823

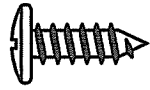

[6]

H156829



[4]

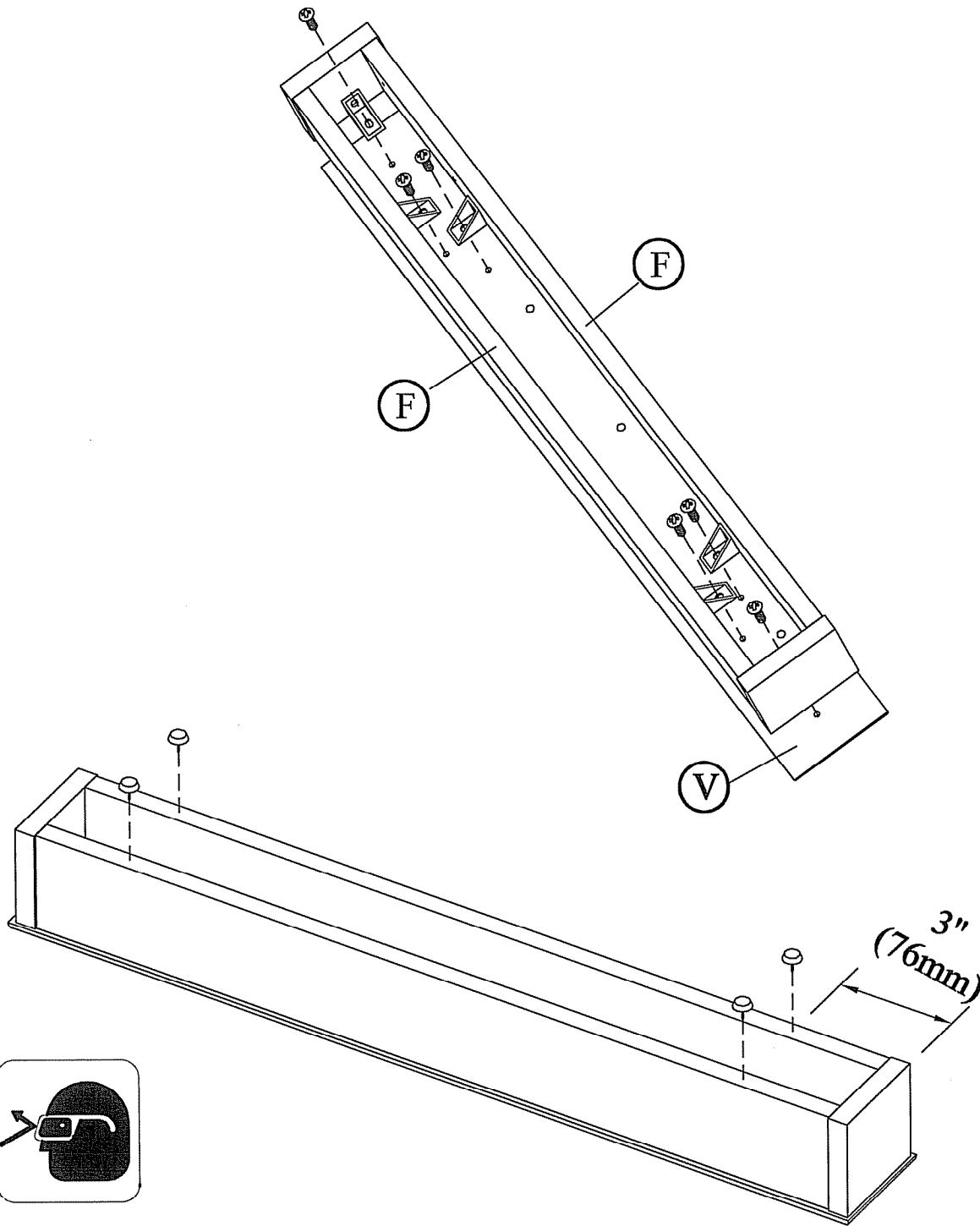

1 - 800 - 950 - 4782

A166351

STEP 16

H157125 

[12]

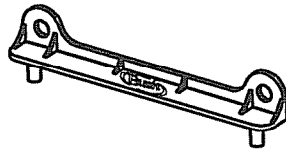
H100446 

[6]

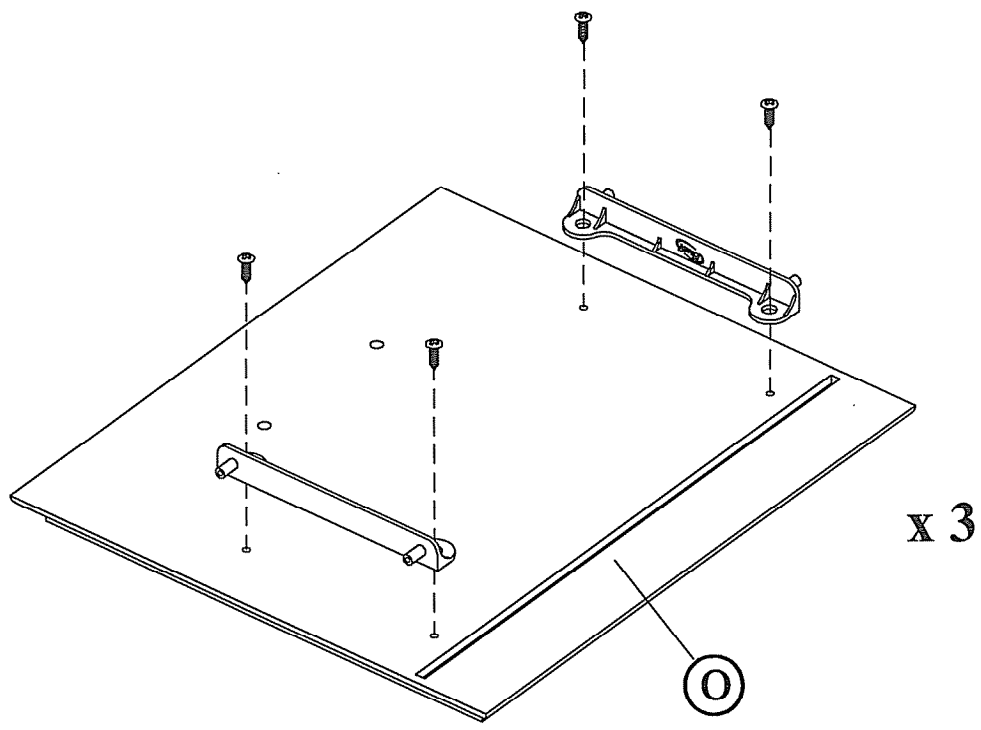

1 - 800 - 950 - 4782

A166351

STEP 17

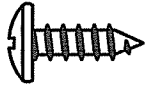
H156824  [18]

Z38723  [6]

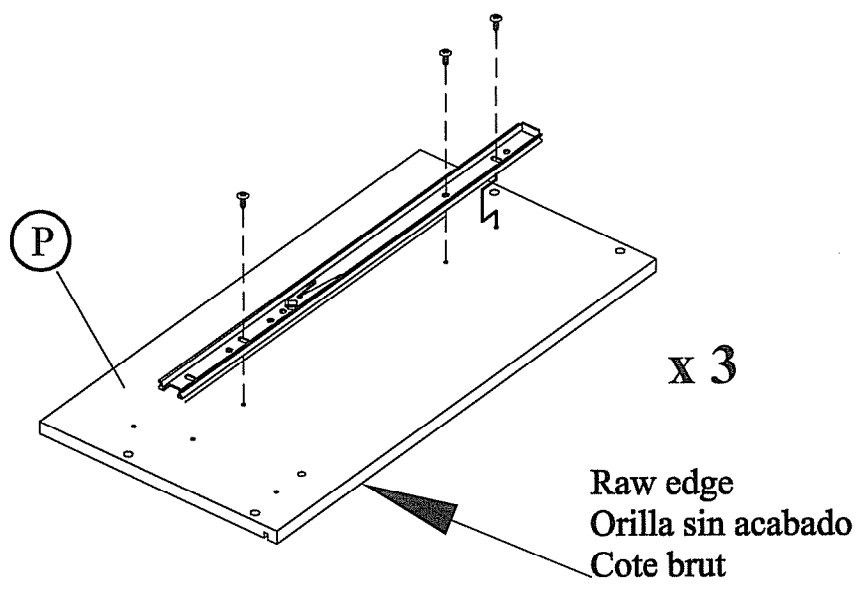
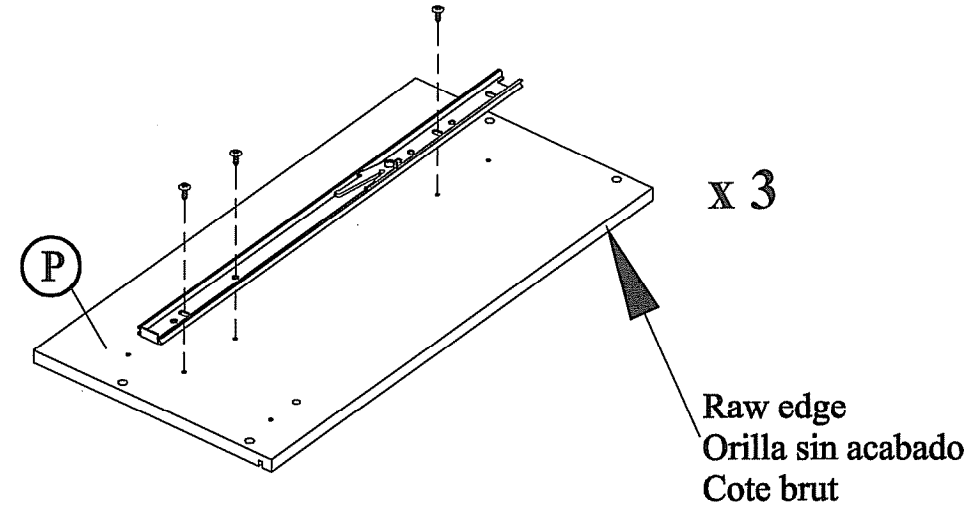

1 - 800 - 950 - 4782

A166351

STEP 18

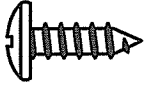
H156824 

[12]

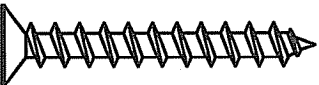
H156821  [12]

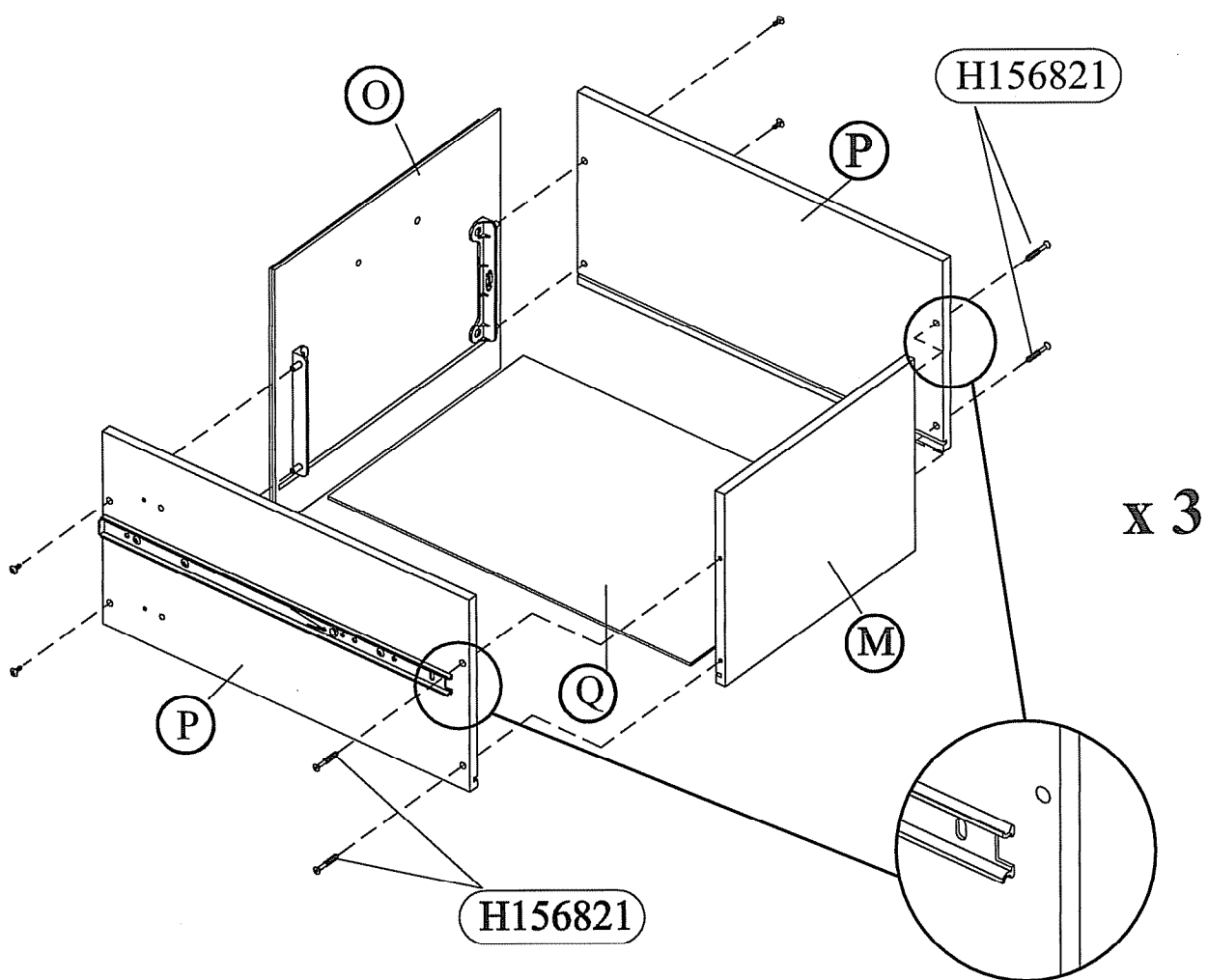

STEP 19

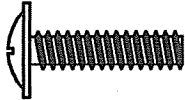
H158559  [6]

H150085

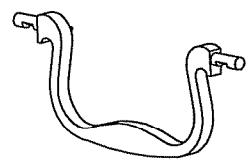

[3]

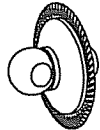
H150086  [6]

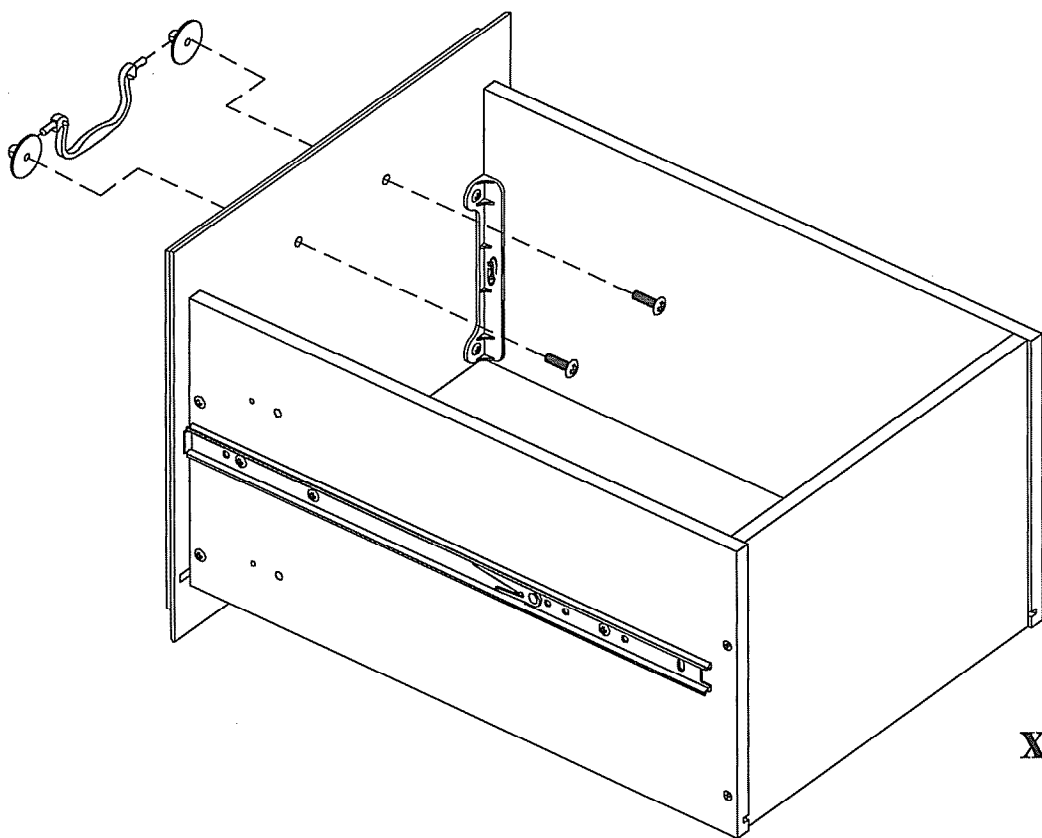

x 3

STEP 20

- H153477 [6] H153475 [3]
- H89793 [3]

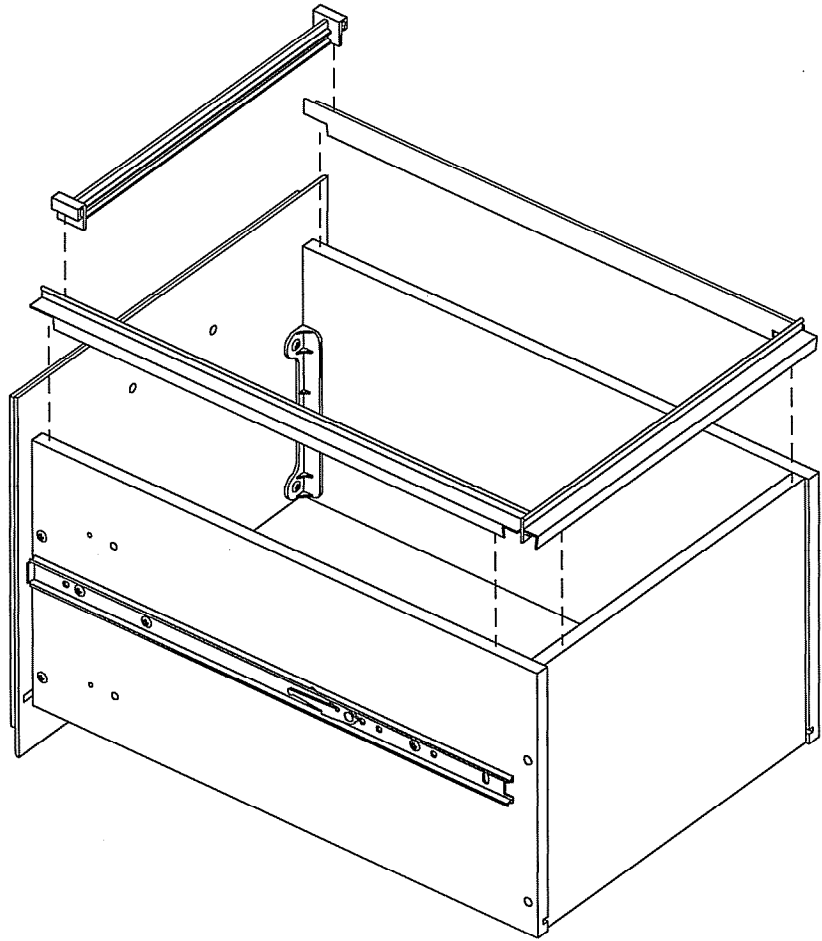

x 3

1 - 800 - 950 - 4782

A166351

STEP 21

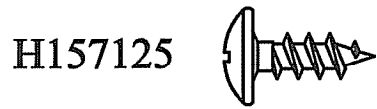

[4]

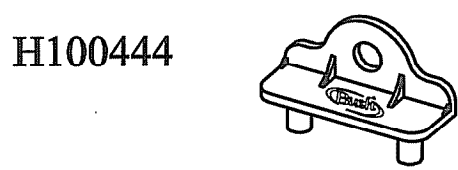

[4]

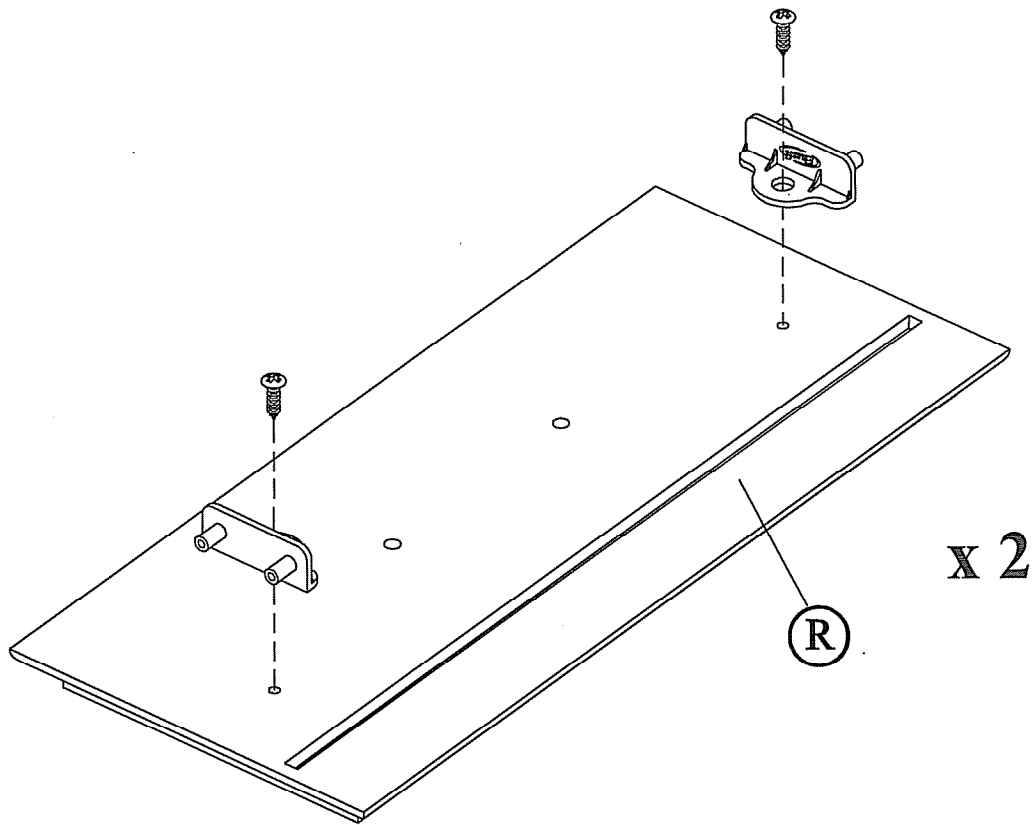

STEP 22

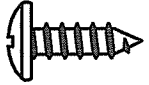
H156824 

[8]

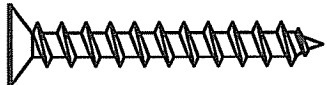
H156821  [8]

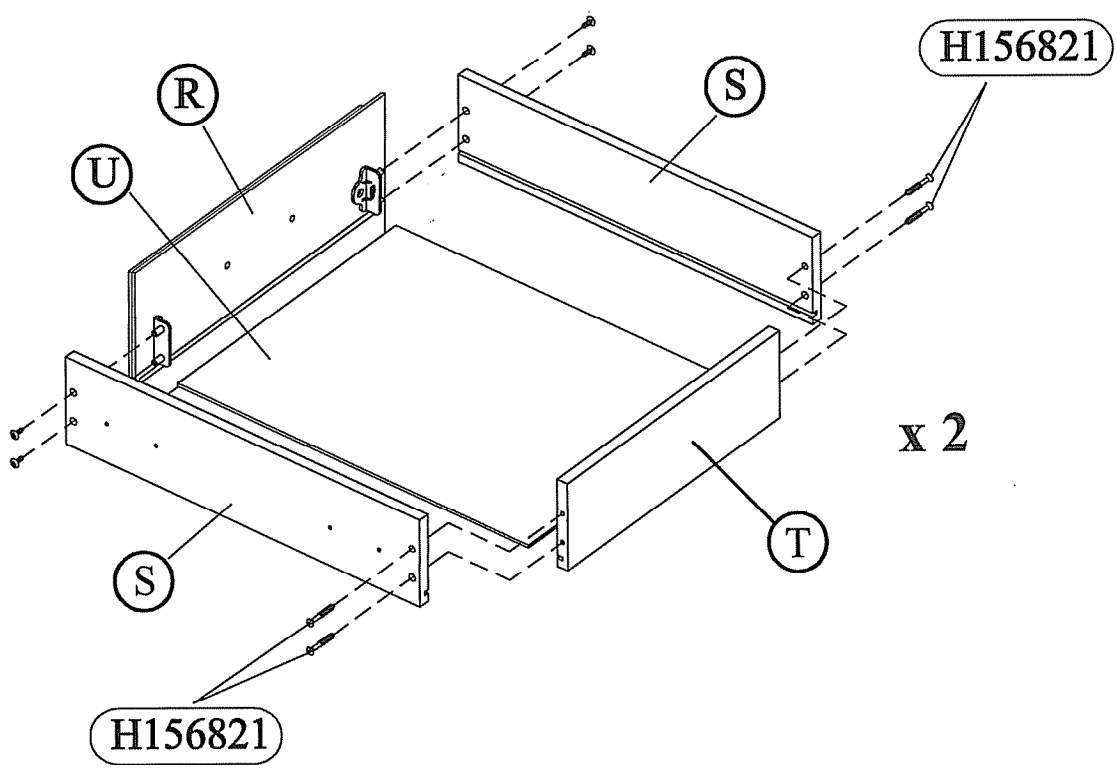

STEP 23

Z89900 [2] H156825 [12]

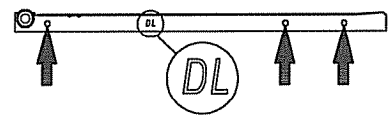

Z89901 [2]

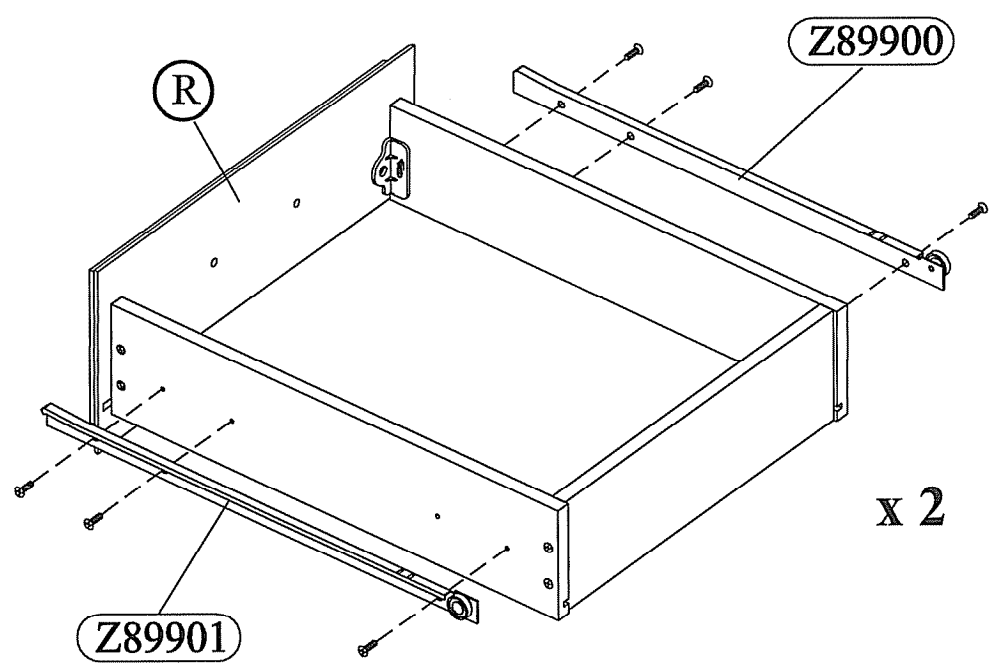
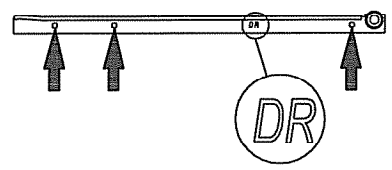

STEP 24

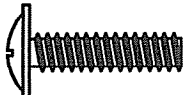
H158559  [4]

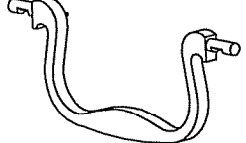
H150085  [2]

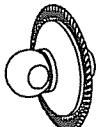
H150086  [4]

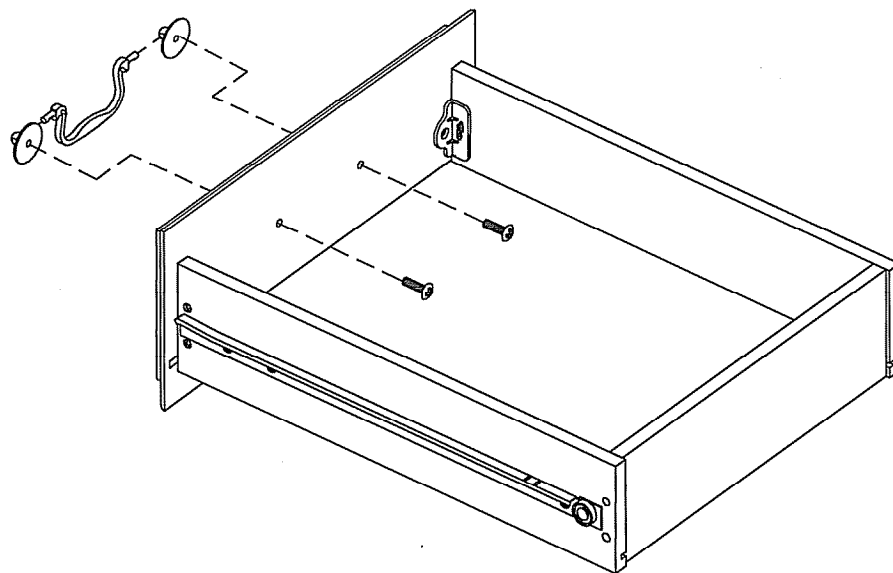

x 2

STEP 25

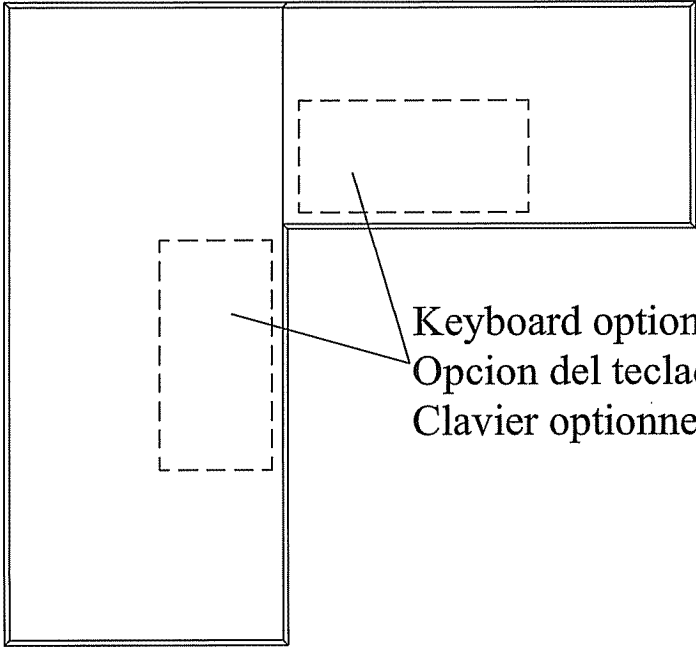

Go to step 26.
Proceda al paso 26.
Allez à l'étape 26.

Keyboard option
Opcion del teclado
Clavier optionnel

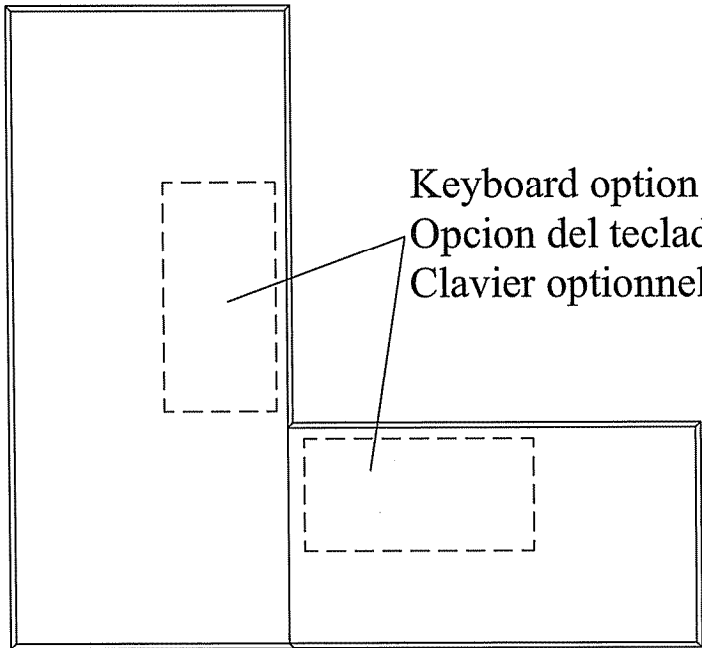

Keyboard option
Opcion del teclado
Clavier optionnel

Go to step 41.
Proceda al paso 41.
Allez à l'étape 41.

STEP 26

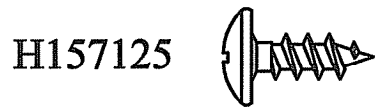

H157125

[1]

H158031



[1]

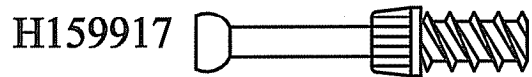

H159917

[2]

H153244



[2]

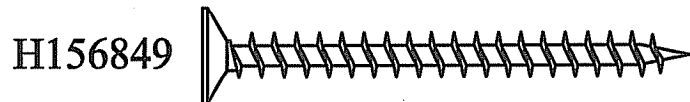

H156849

[5]

H27145



An assistant is required.
Es necesario un ayudante.
Un assistant est nécessaire.

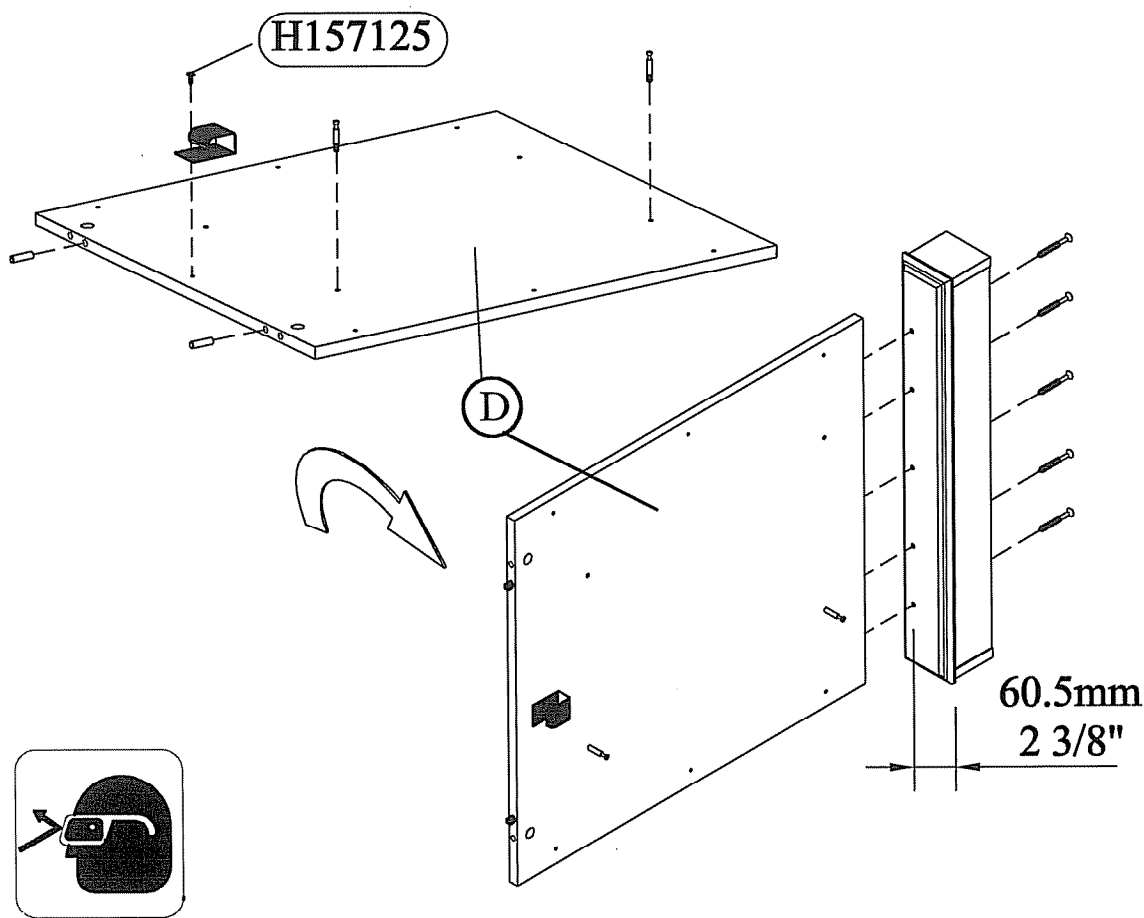

1 - 800 - 950 - 4782

A166351

STEP 27

H159916

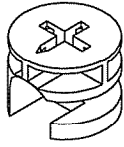

[2]

H158961



[2]

An assistant is required.
Es necesario un ayudante.
Un assistant est nécessaire.

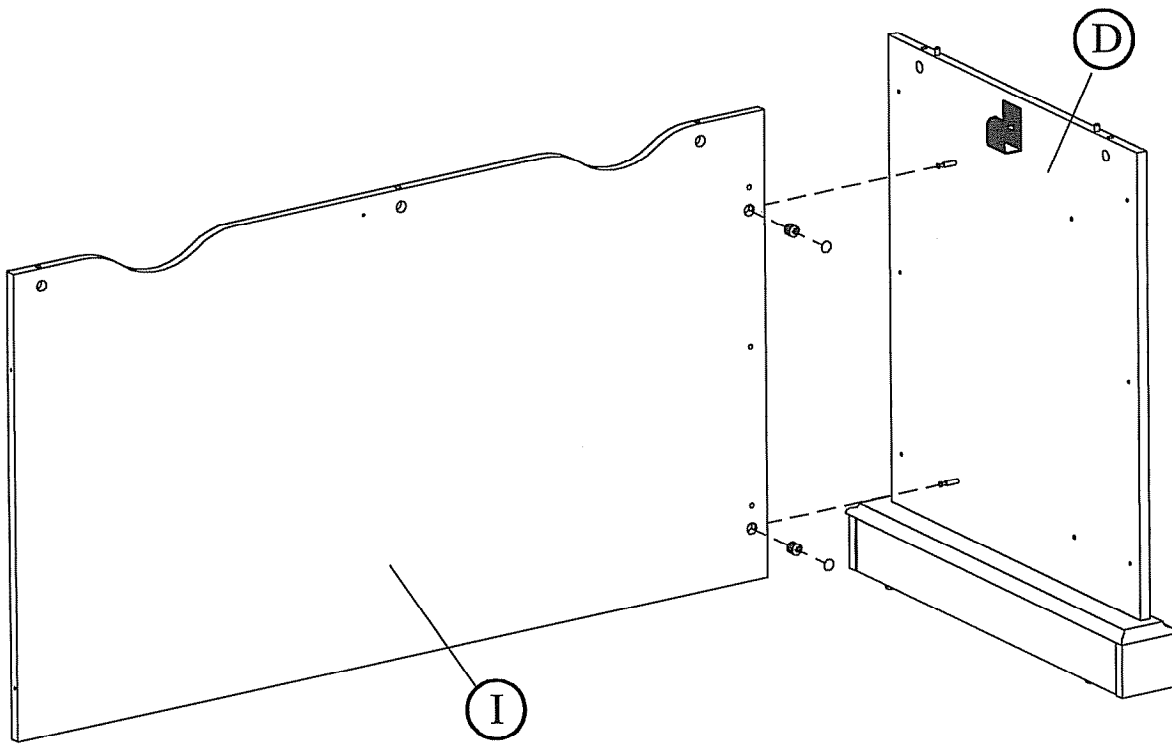

1 - 800 - 950 - 4782

A166351

STEP 28

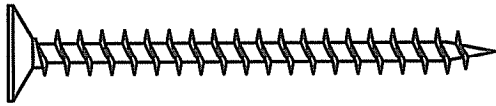
H156849  [2]

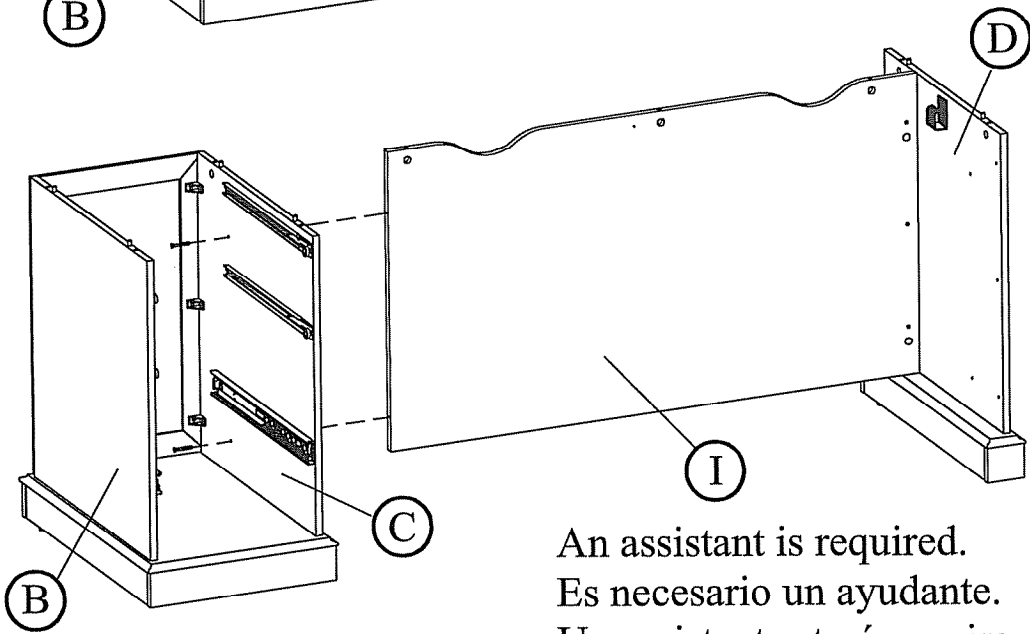
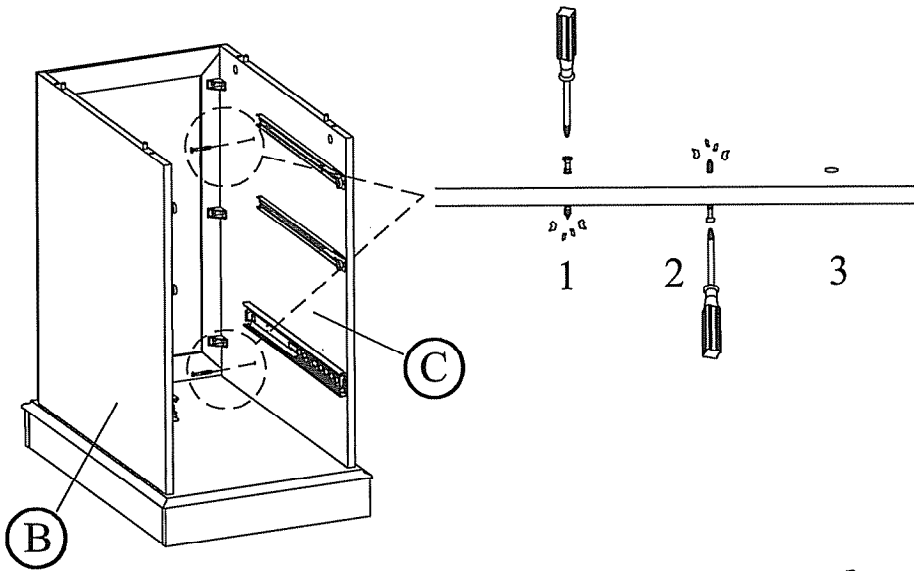

An assistant is required.
 Es necesario un ayudante.
 Un assistant est nécessaire.

1 - 800 - 950 - 4782

A166351

STEP 29

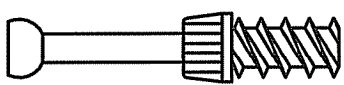
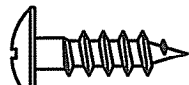
H159917  [9] H157985  [4]

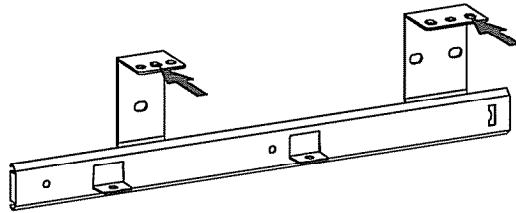
Z92806  [1]

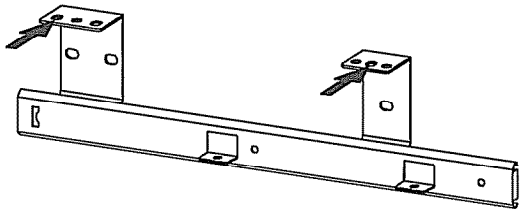
Z92807  [1]

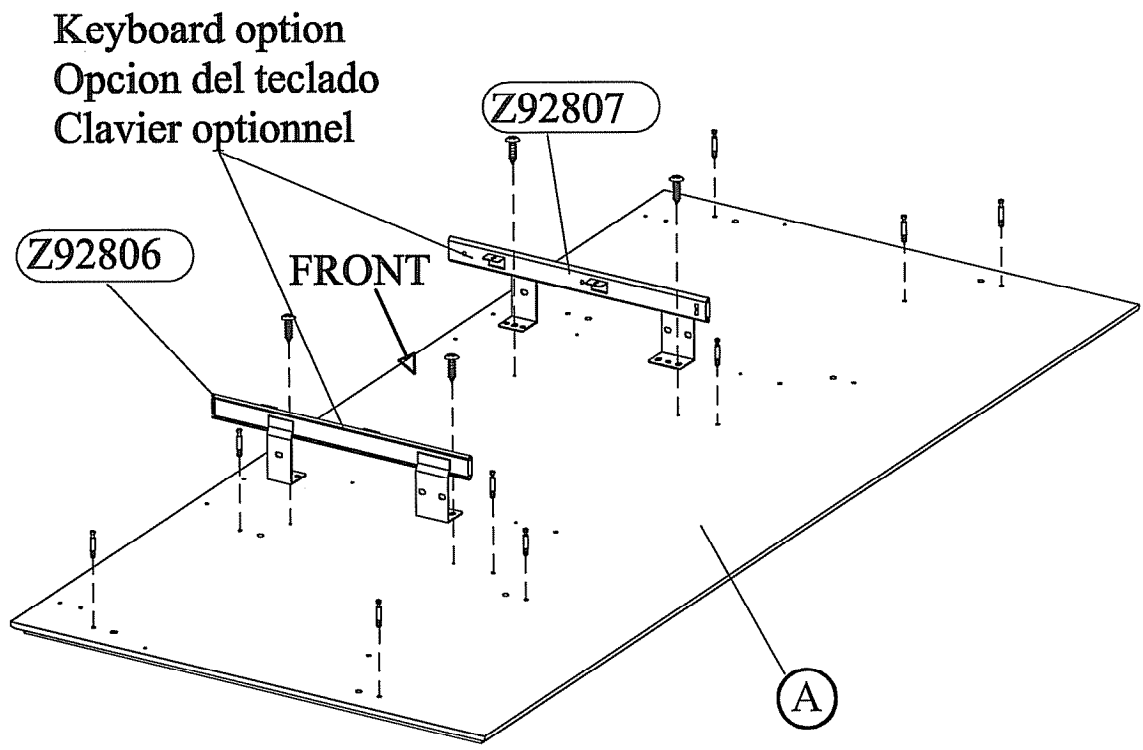

STEP 30

H159916

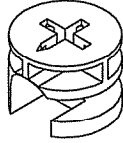

[9]

H158961



[4]

H157125

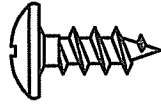

[1]

H158031



[1]

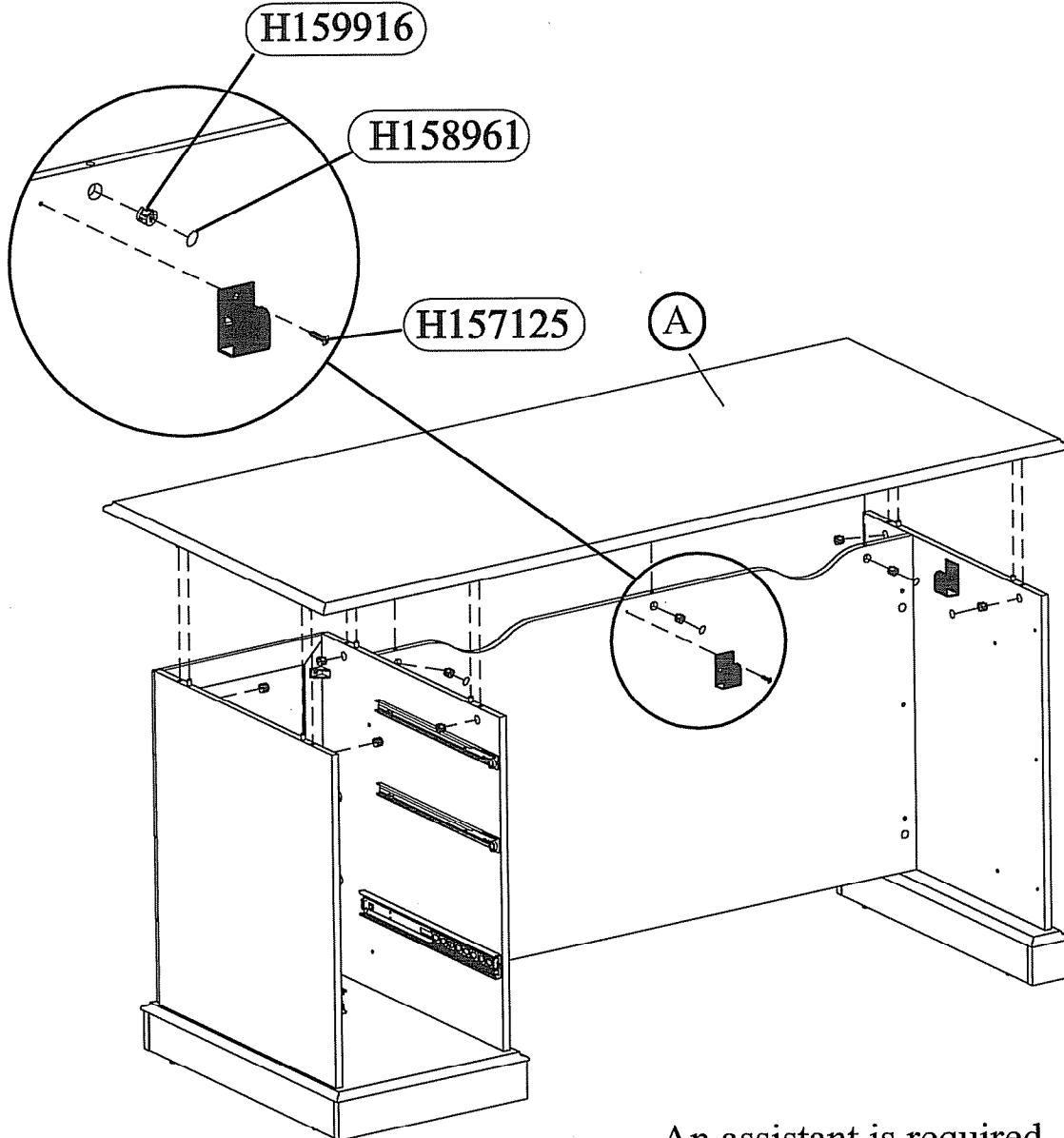



An assistant is required.
 Es necesario un ayudante.
 Un assistant est nécessaire.

1 - 800 - 950 - 4782

A166351

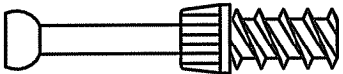
STEP 31

H159917  [2] H153244  [3]

H27145 

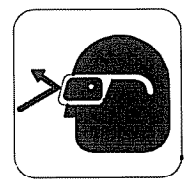
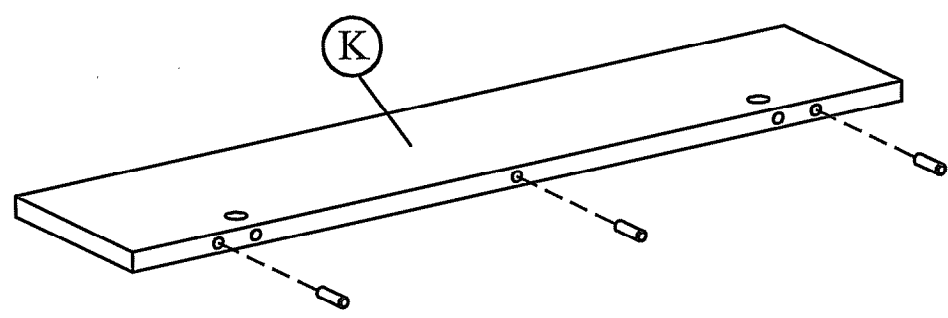
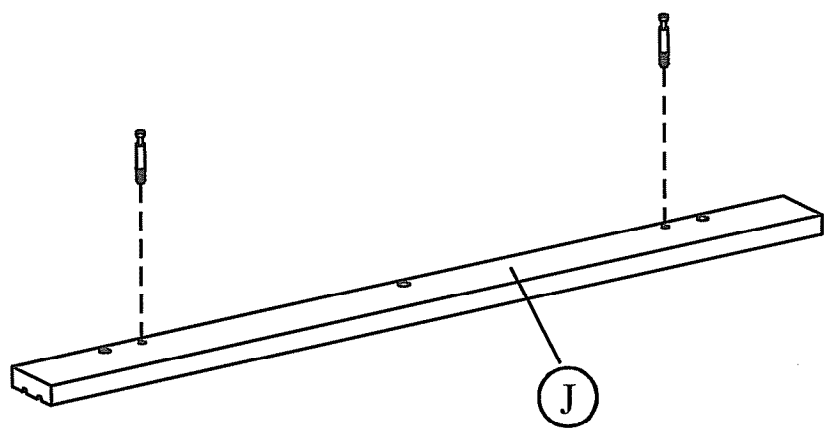

1 - 800 - 950 - 4782

A166351

STEP 32

H159916

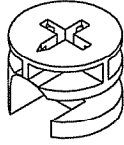

[2]

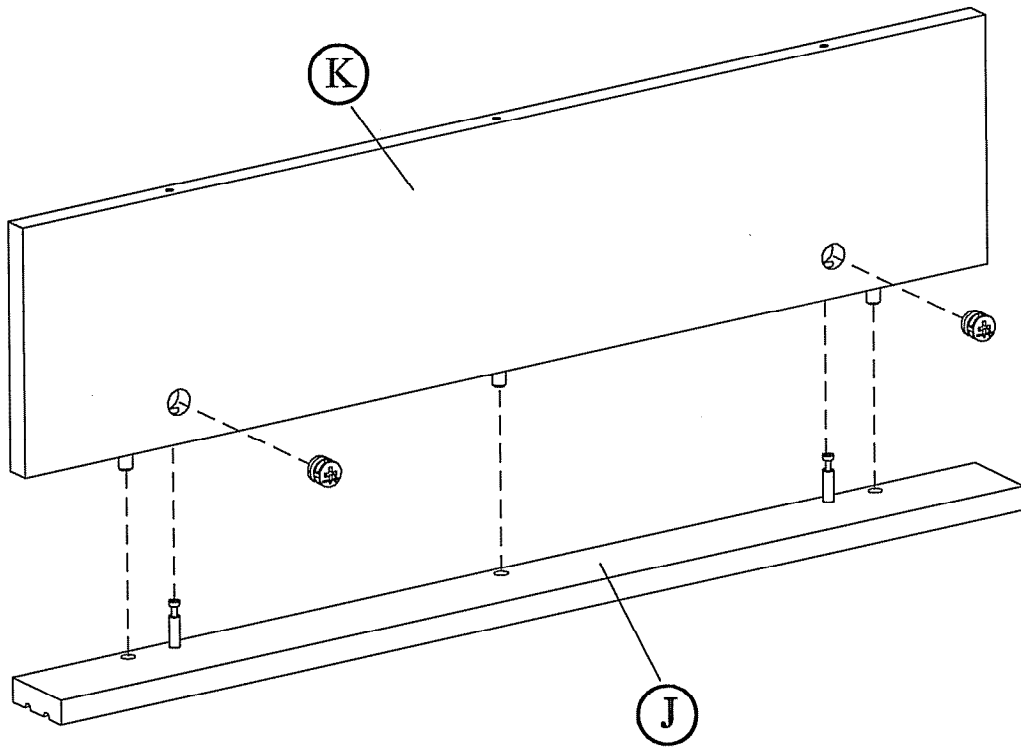

1 - 800 - 950 - 4782

A166351

STEP 33

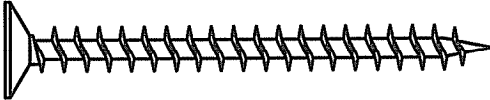
H156849  [3]

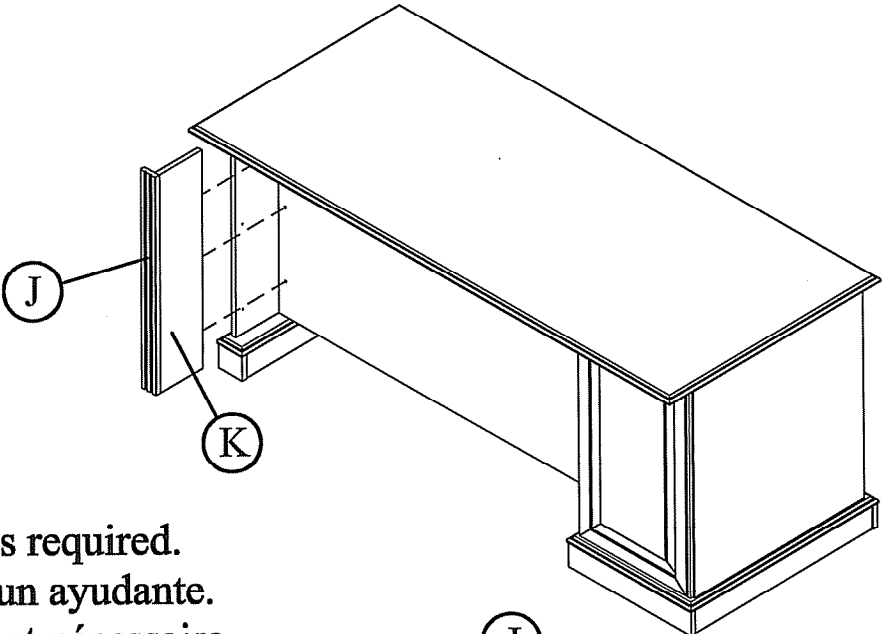

An assistant is required.
Es necesario un ayudante.
Un assistant est nécessaire.

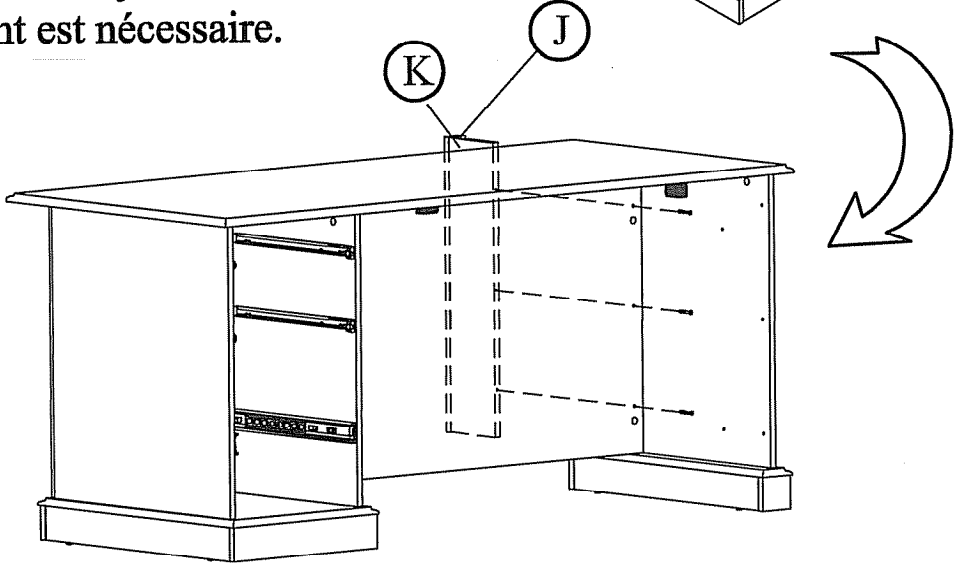

1 - 800 - 950 - 4782

A166351

STEP 34

H153244  [3]

H27145 

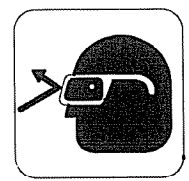
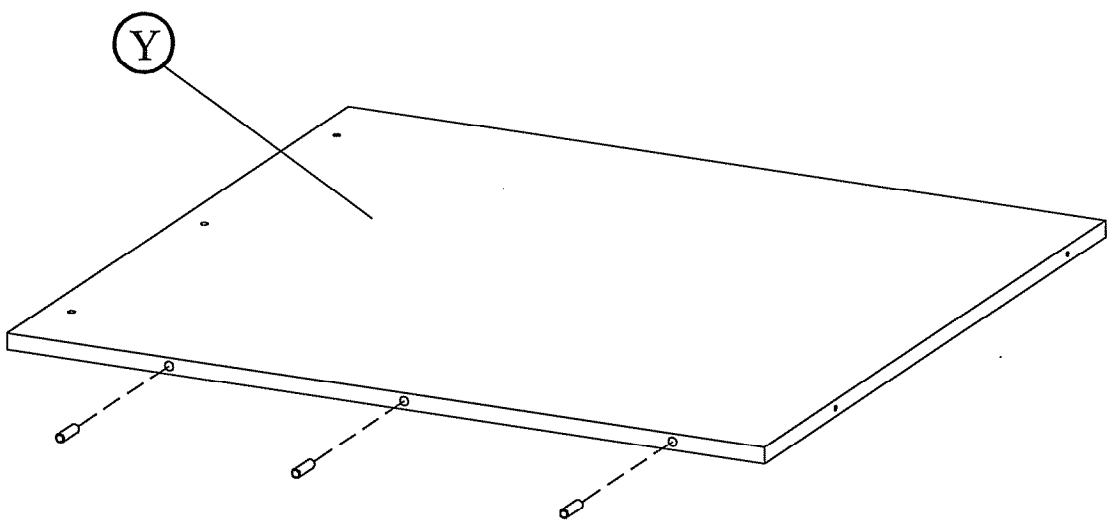

 1 - 800 - 950 - 4782

A166351

STEP 35

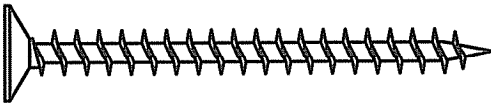
H156849  [2]

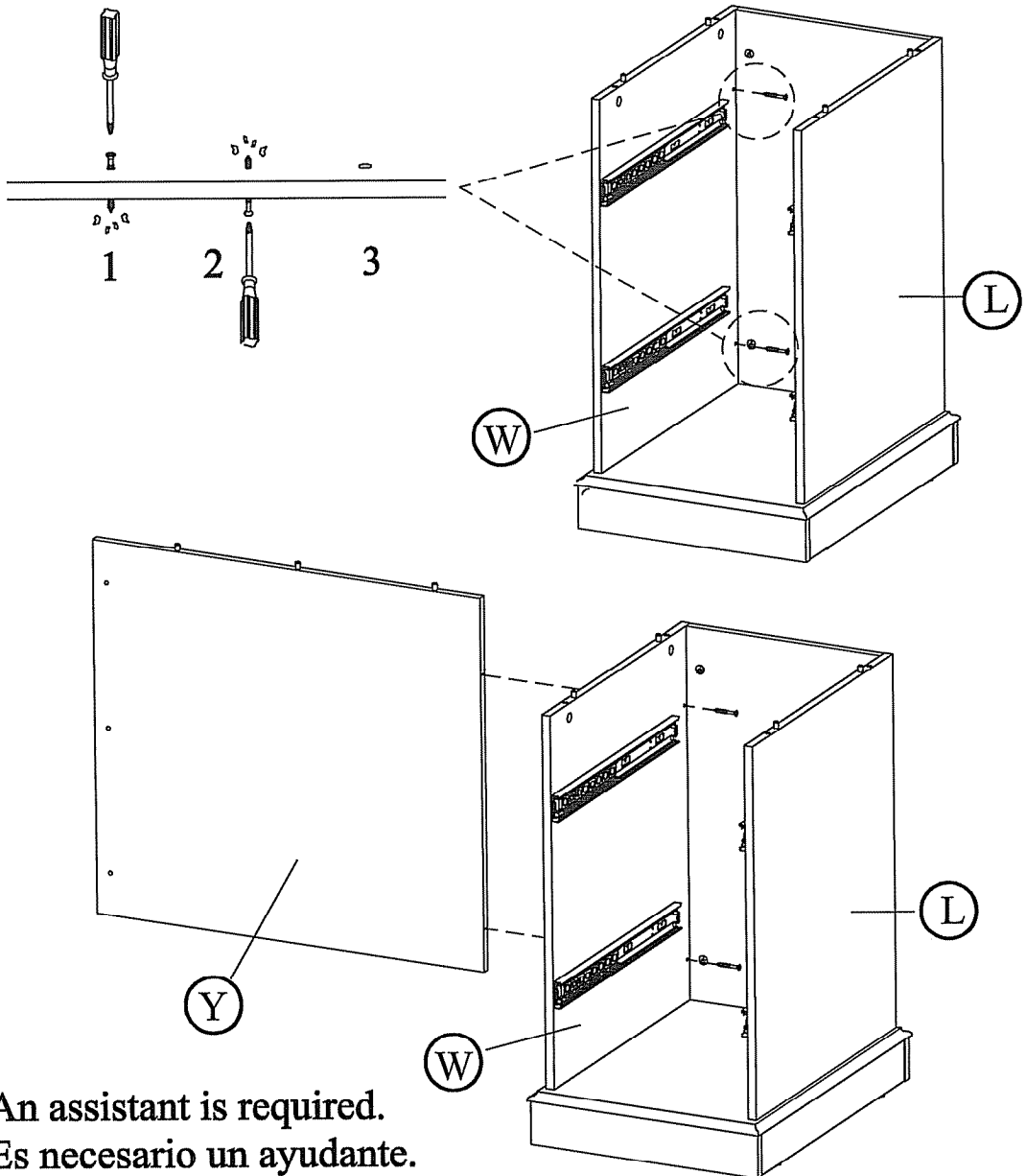

An assistant is required.
 Es necesario un ayudante.
 Un assistant est nécessaire.

1 - 800 - 950 - 4782

A166351

STEP 36

- | | | | | | |
|---------|--|-------|---------|--|-------|
| H159917 | | [4] | H157985 | | [7] |
| Z92806 | | [1] | H157125 | | [1] |
| Z92807 | | [1] | H158031 | | [1] |
| H39922 | | [1] | H158981 | | [1] |

Keyboard option
 Opcion del teclado
 Clavier optionnel

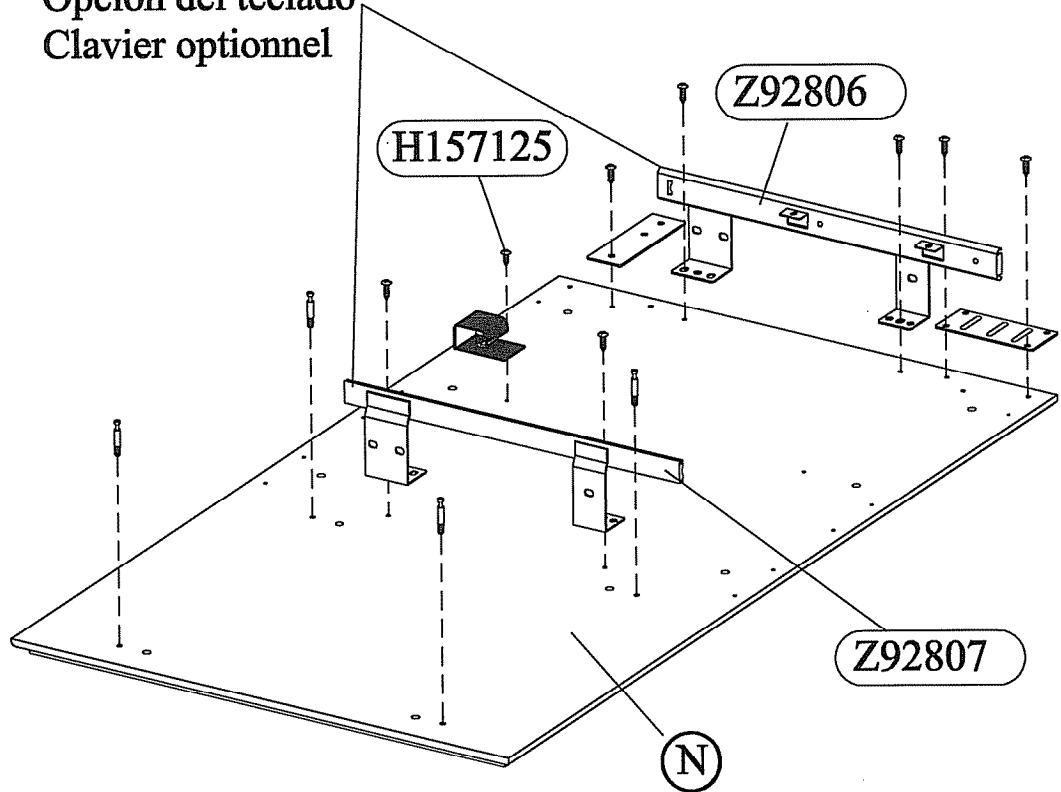

1 - 800 - 950 - 4782

A166351

STEP 37

H159916

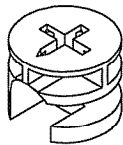

[4]

An assistant is required.
Es necesario un ayudante.
Un assistant est nécessaire.

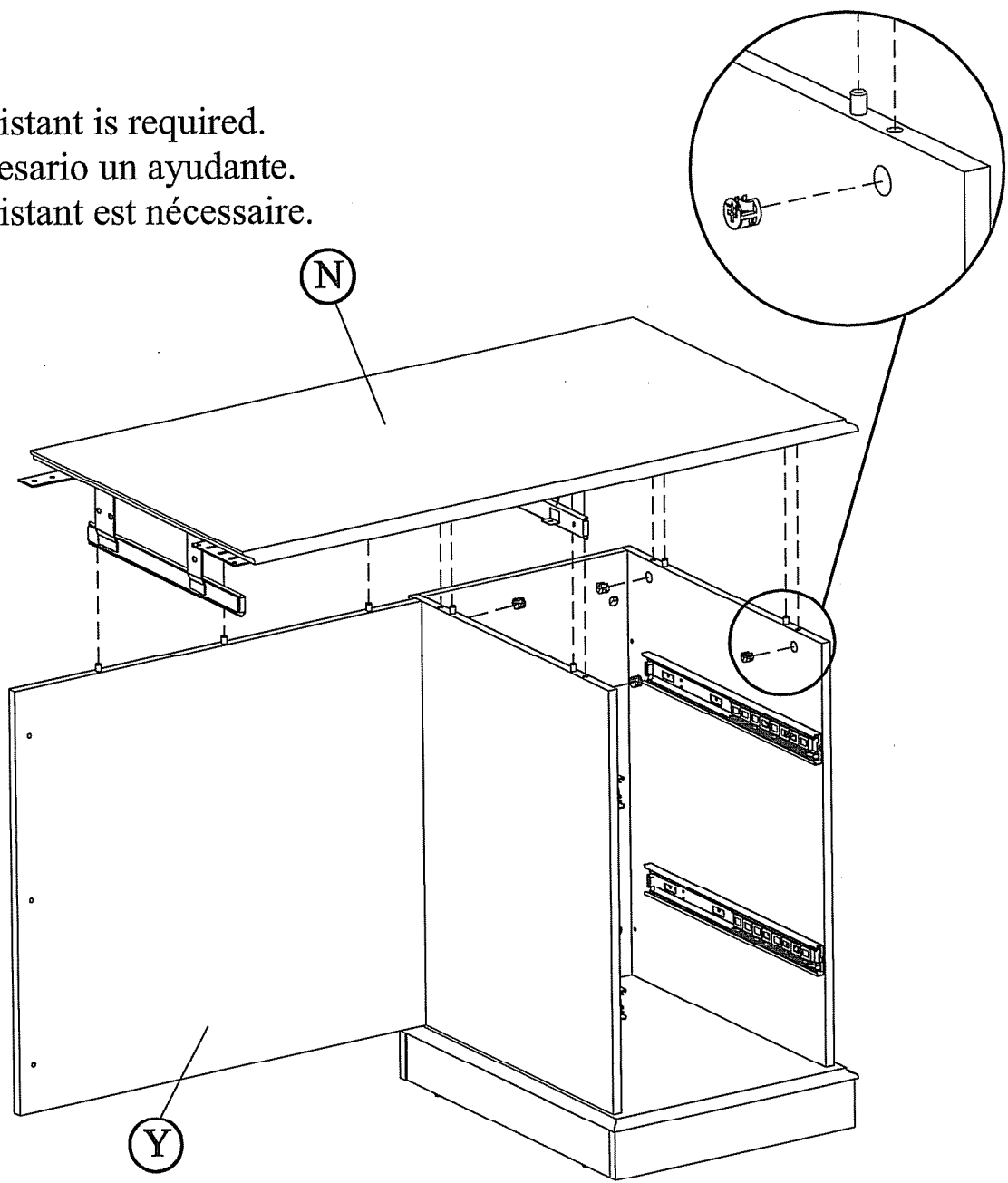

1 - 800 - 950 - 4782

A166351

STEP 38

H157985

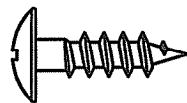

[4]

H158560

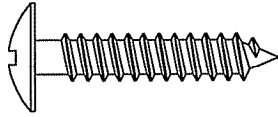

[3]

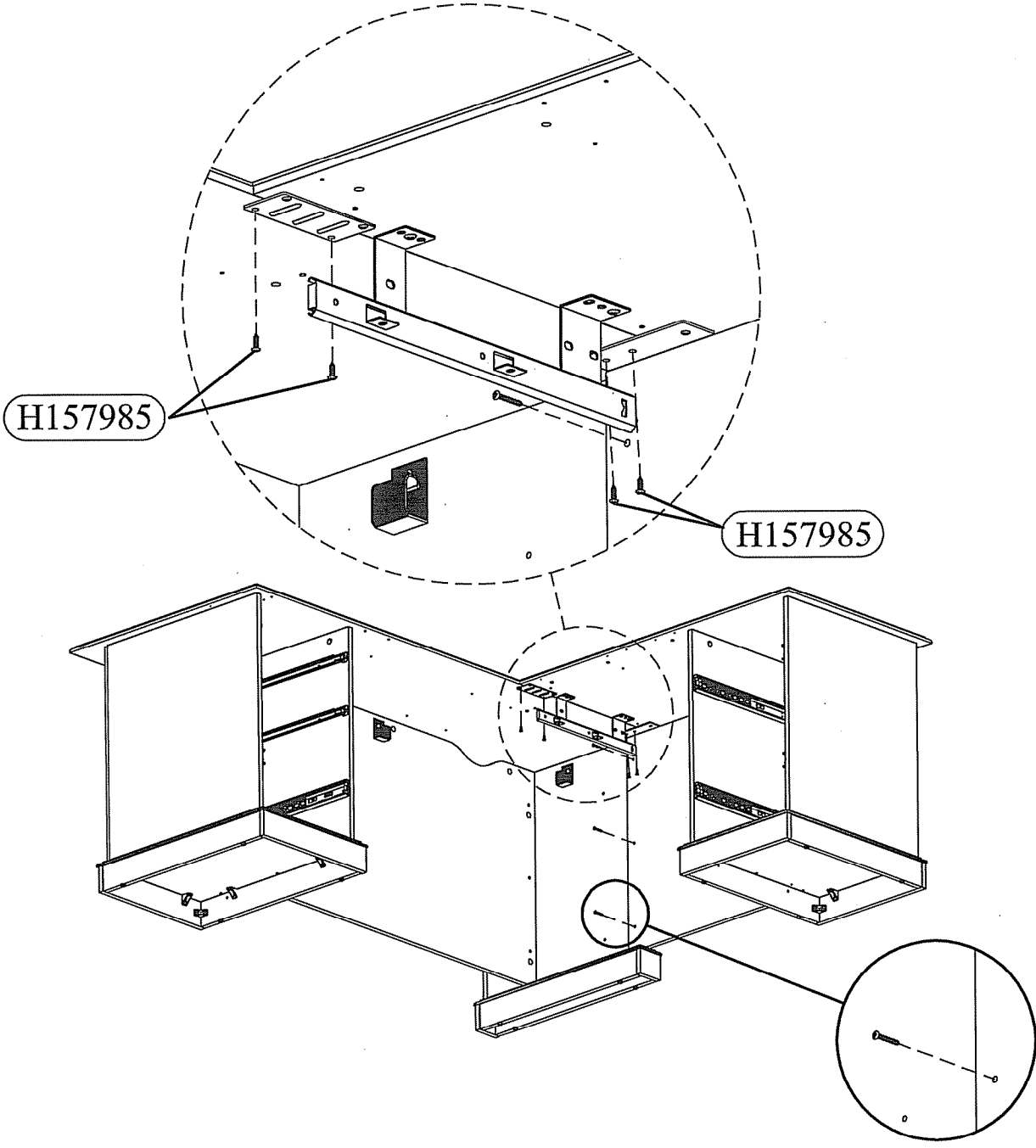

1 - 800 - 950 - 4782

A166351

STEP 39

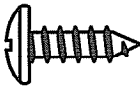
H156824  [4]

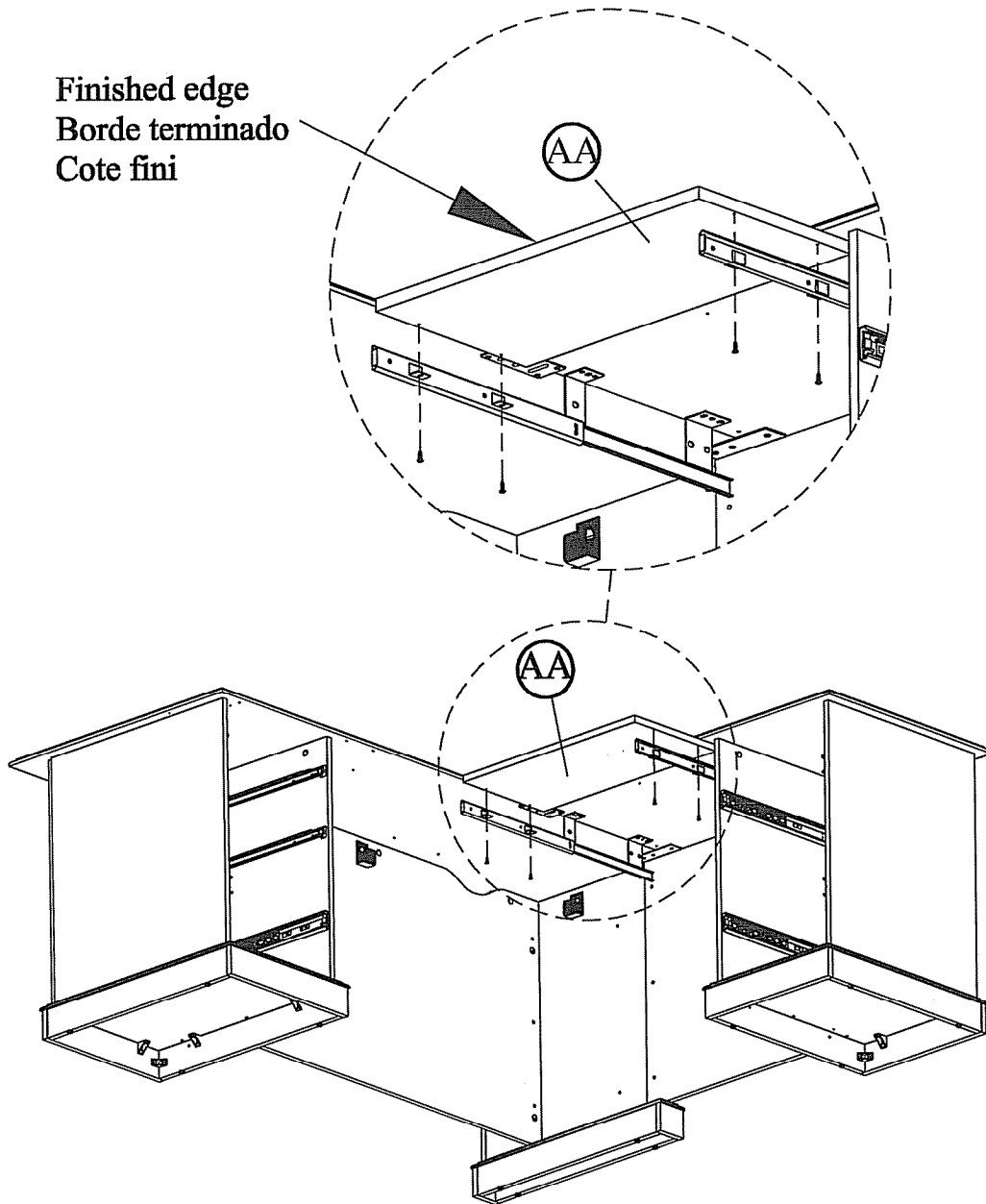

1 - 800 - 950 - 4782

A166351

STEP 40

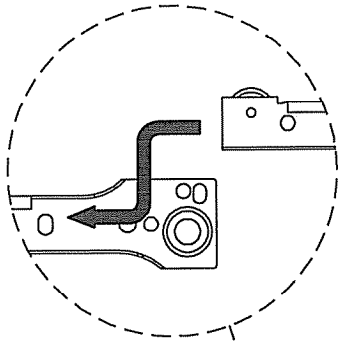

Keyboard option
 Opcion del teclado
 Clavier optionnel

Go to step 56.
 Proceda al paso 56.
 Allez à l'étape 56.

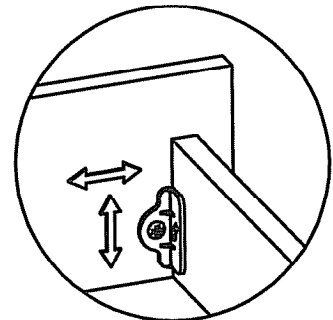
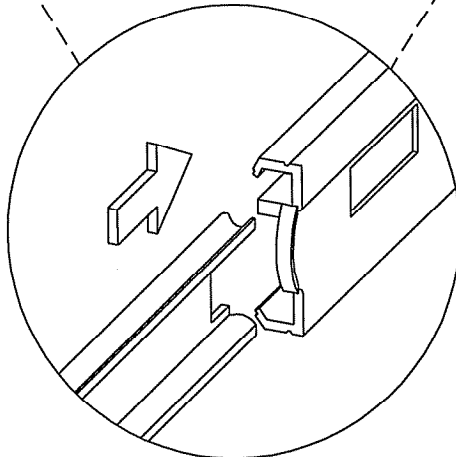
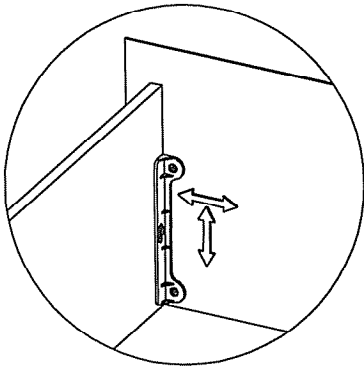
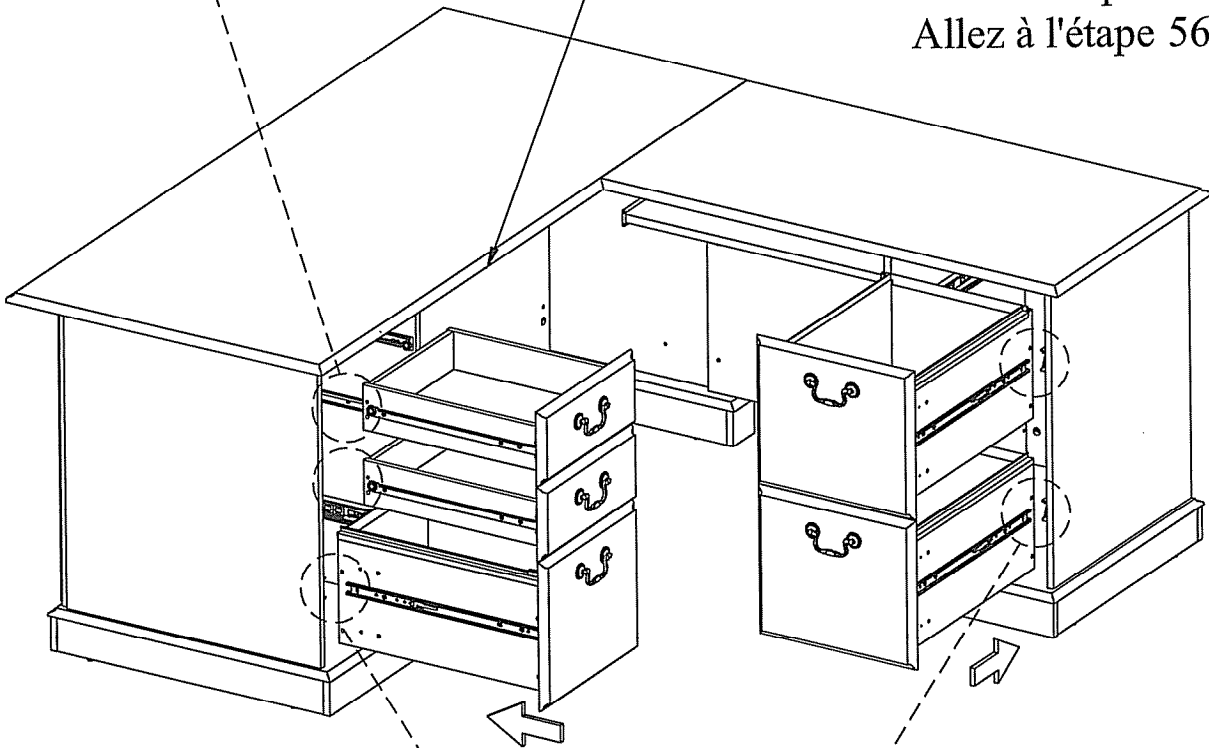

1 - 800 - 950 - 4782

A166351

STEP 41

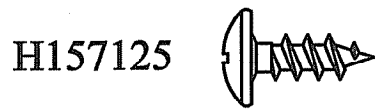

[1]

H158031



[1]

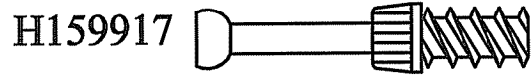

[2]

H153244



[2]

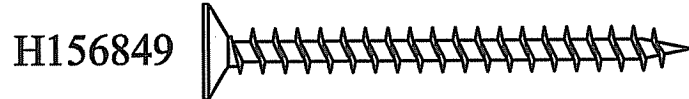

[5]

H27145

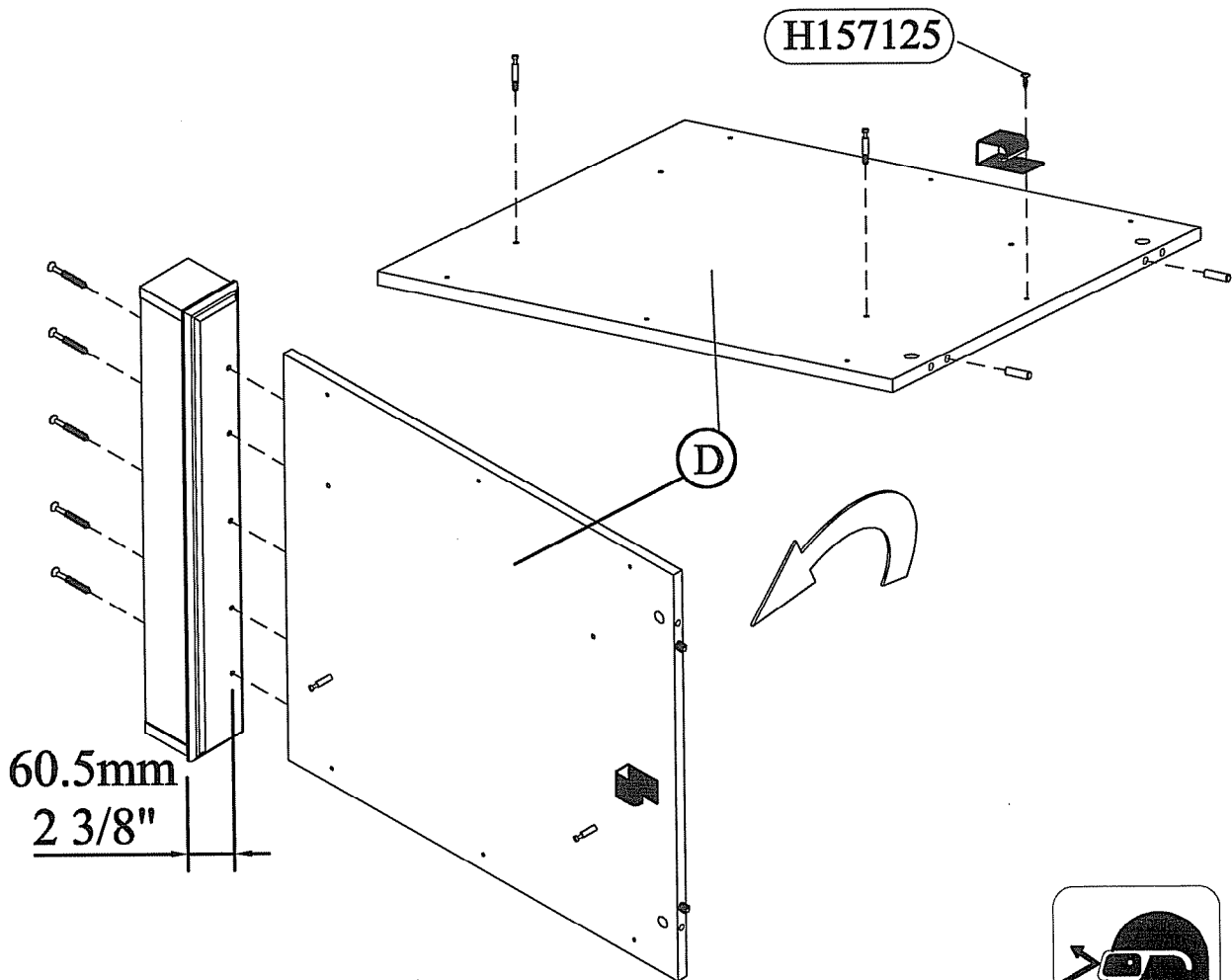

60.5mm
2 3/8"

An assistant is required.
Es necesario un ayudante.
Un assistant est nécessaire.

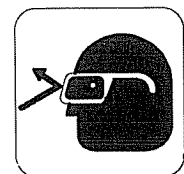

1 - 800 - 950 - 4782

A166351

STEP 42

H159916

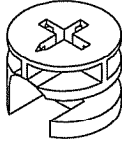

[2]

H158961

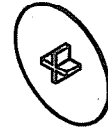

[2]

An assistant is required.
Es necesario un ayudante.
Un assistant est nécessaire.

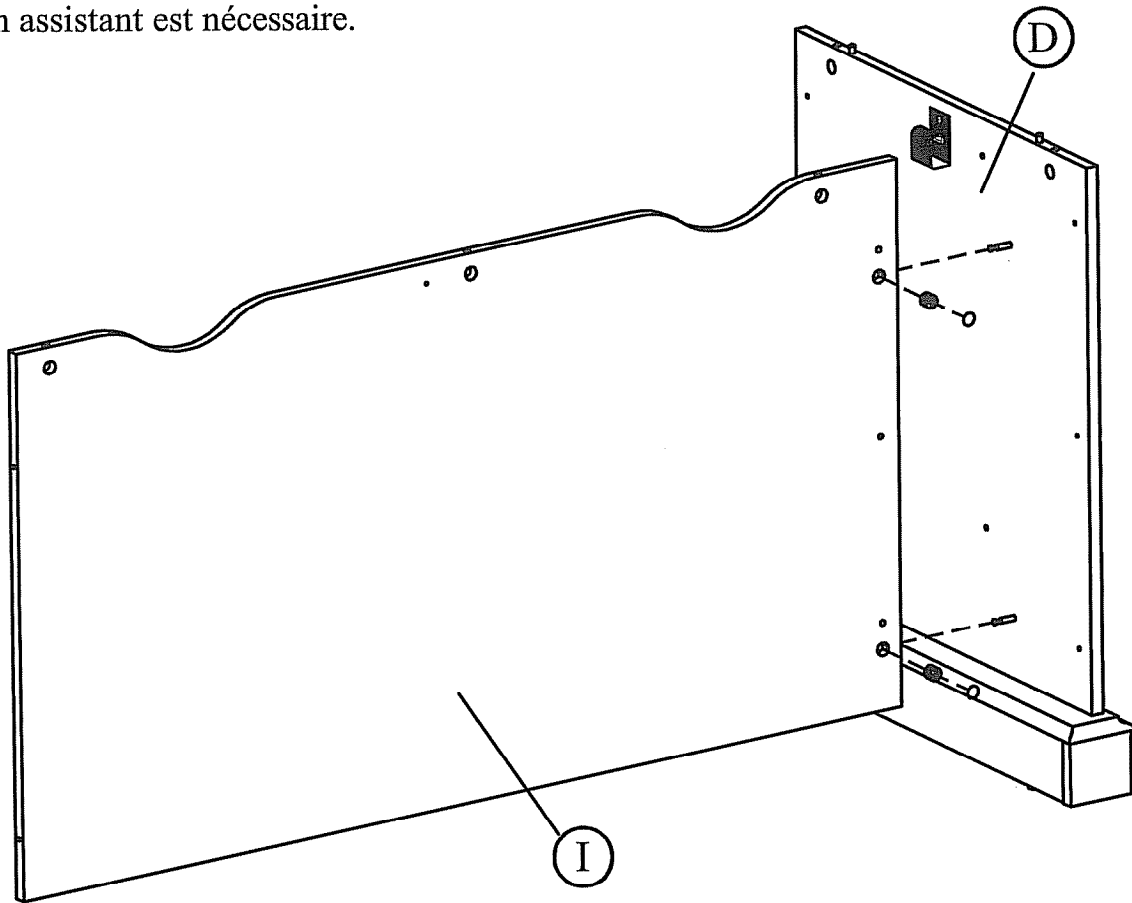

1 - 800 - 950 - 4782

A166351

STEP 43

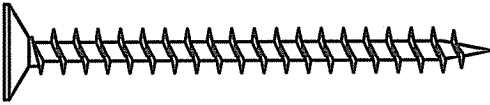
H156849  [2]

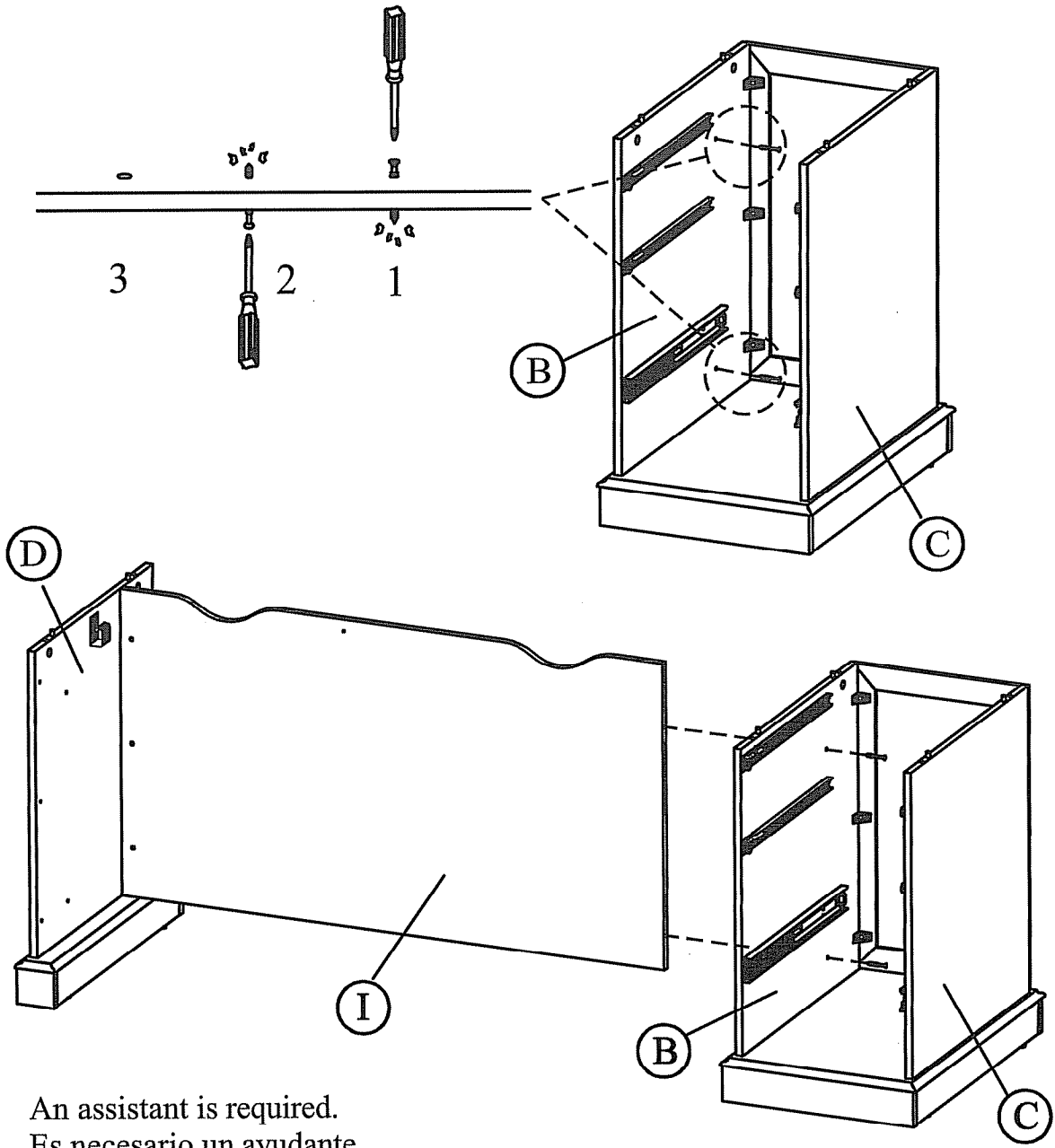

An assistant is required.
 Es necesario un ayudante.
 Un assistant est nécessaire.

 1 - 800 - 950 - 4782

A166351

STEP 44

H159917 [9] H157985 [4]

Z92806 [1]

Z92807 [1]

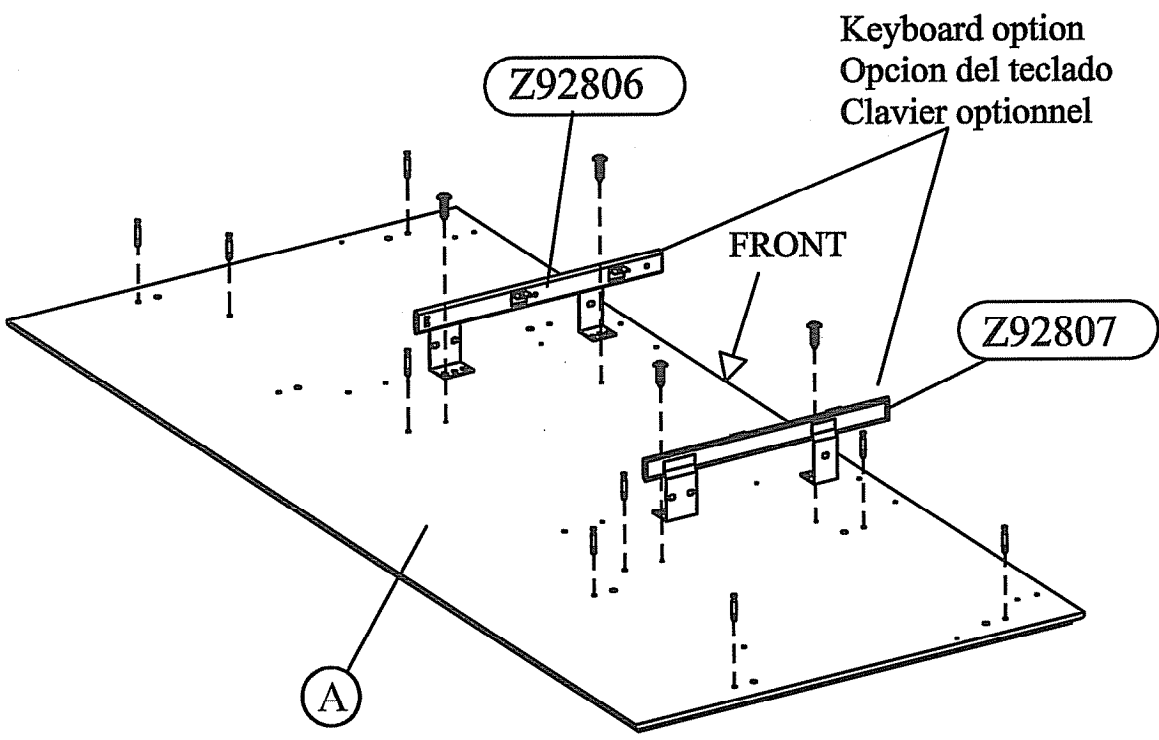

STEP 45

H159916

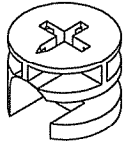

[9]

H158961



[4]

H157125

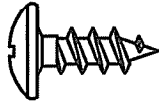

[1]

H158031



[1]

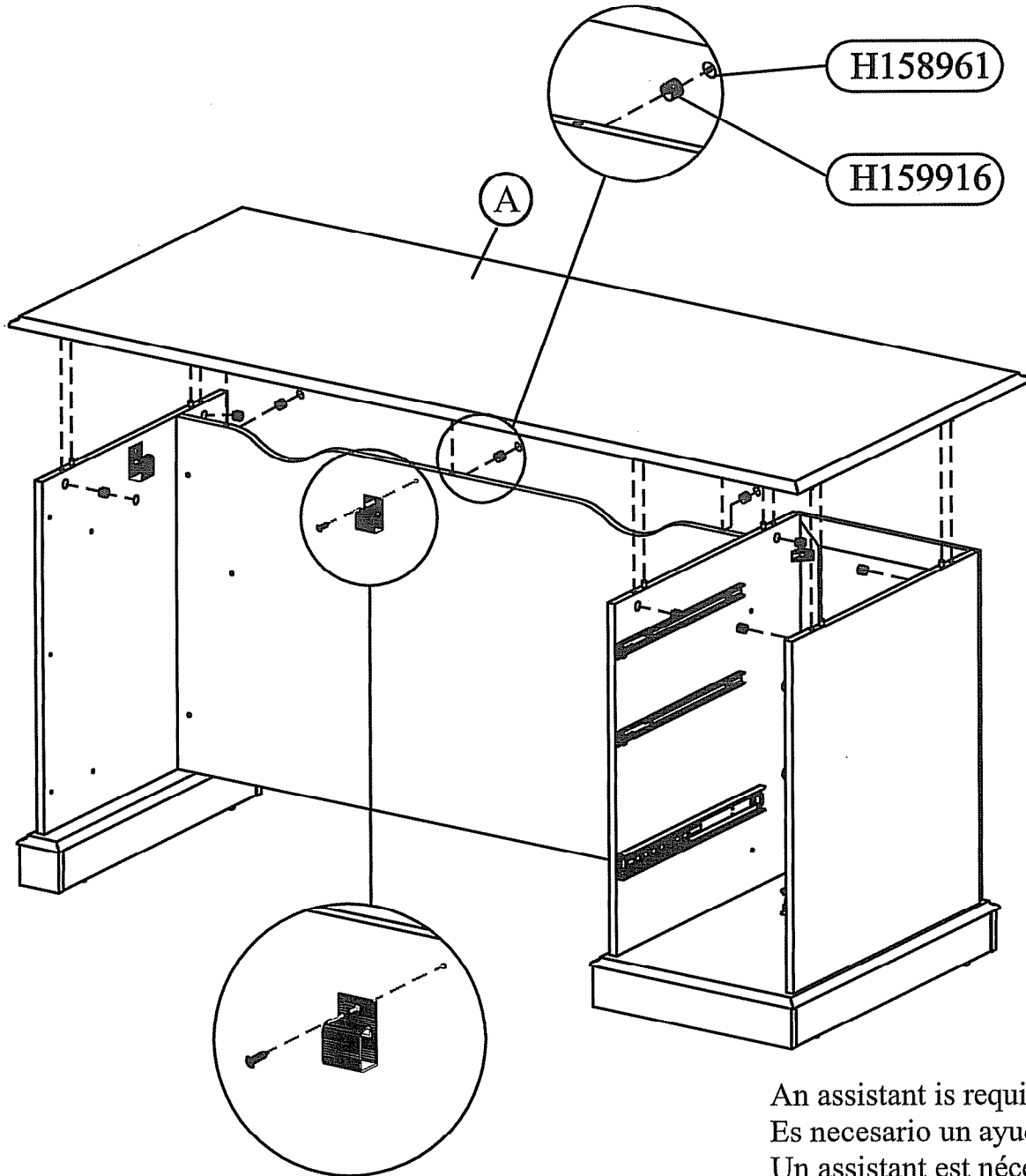



An assistant is required.
 Es necesario un ayudante.
 Un assistant est nécessaire

1 - 800 - 950 - 4782

A166351

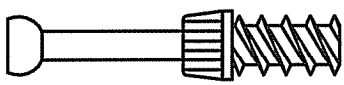
STEP 46

H159917  [2] H153244  [3]

H27145 

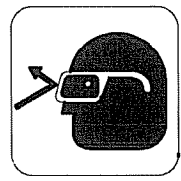
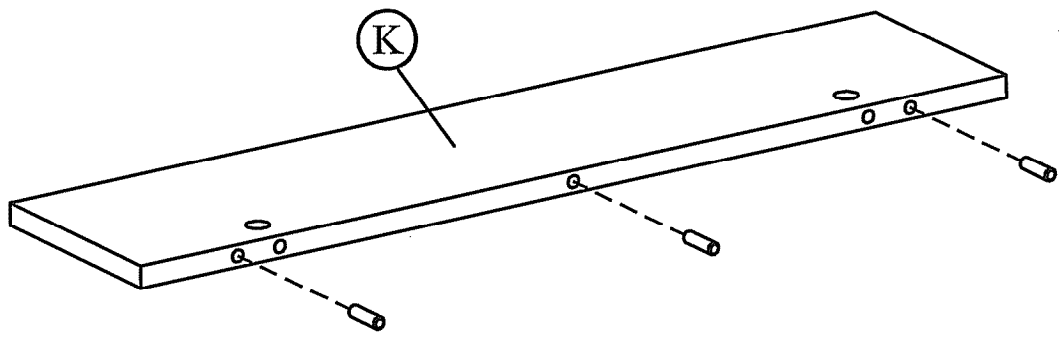
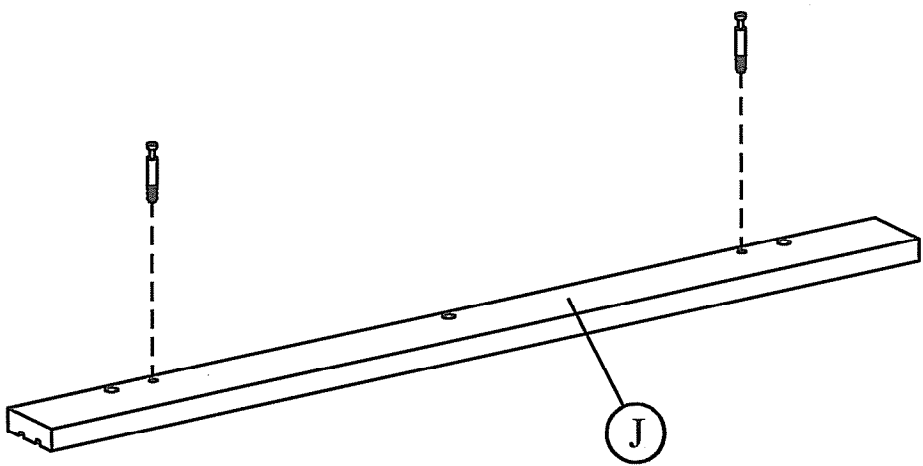

1 - 800 - 950 - 4782

A166351

STEP 47

H159916

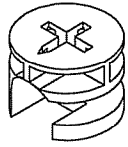

[2]

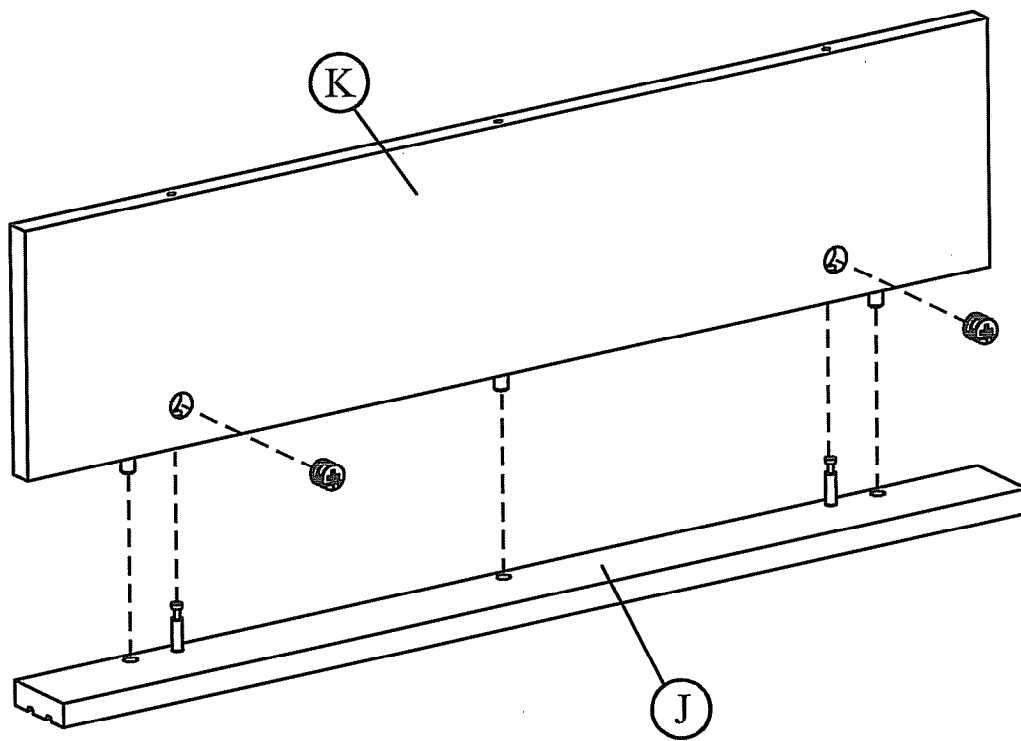

1 - 800 - 950 - 4782

A166351

STEP 48

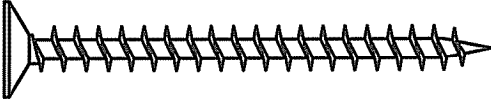
H156849  [3]

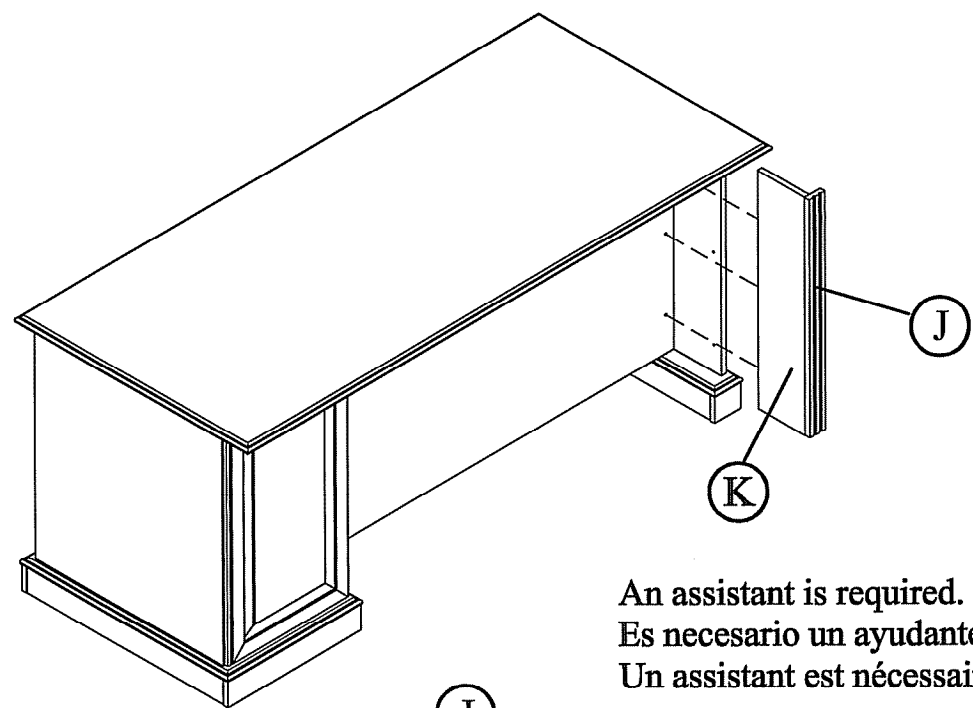

An assistant is required.
Es necesario un ayudante.
Un assistant est nécessaire.

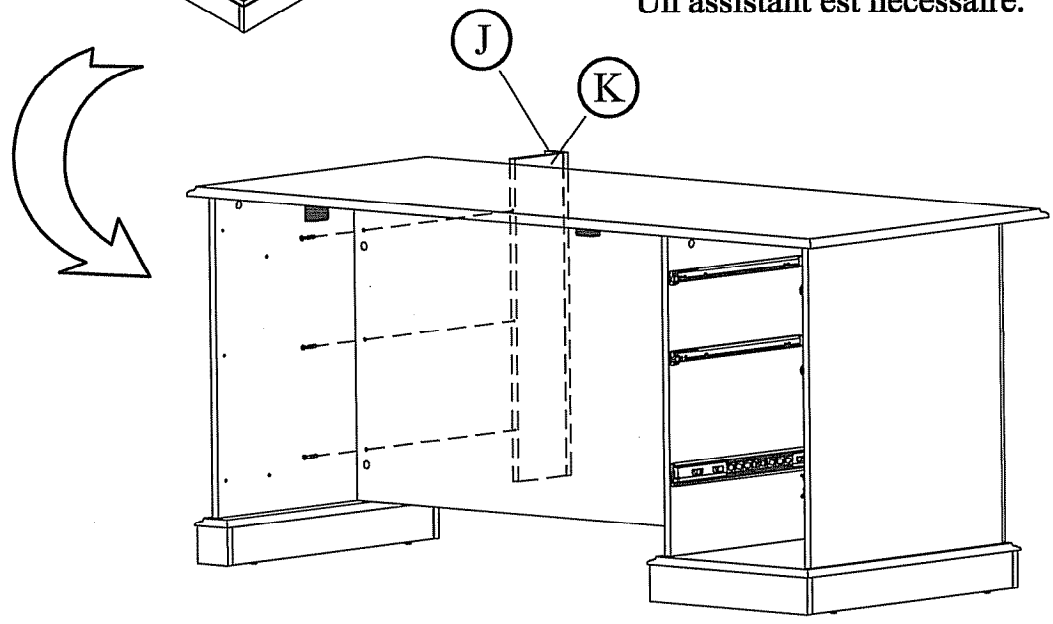

1 - 800 - 950 - 4782

A166351

STEP 49

H153244  [3]

H27145 

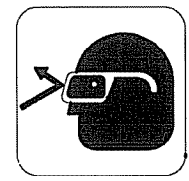
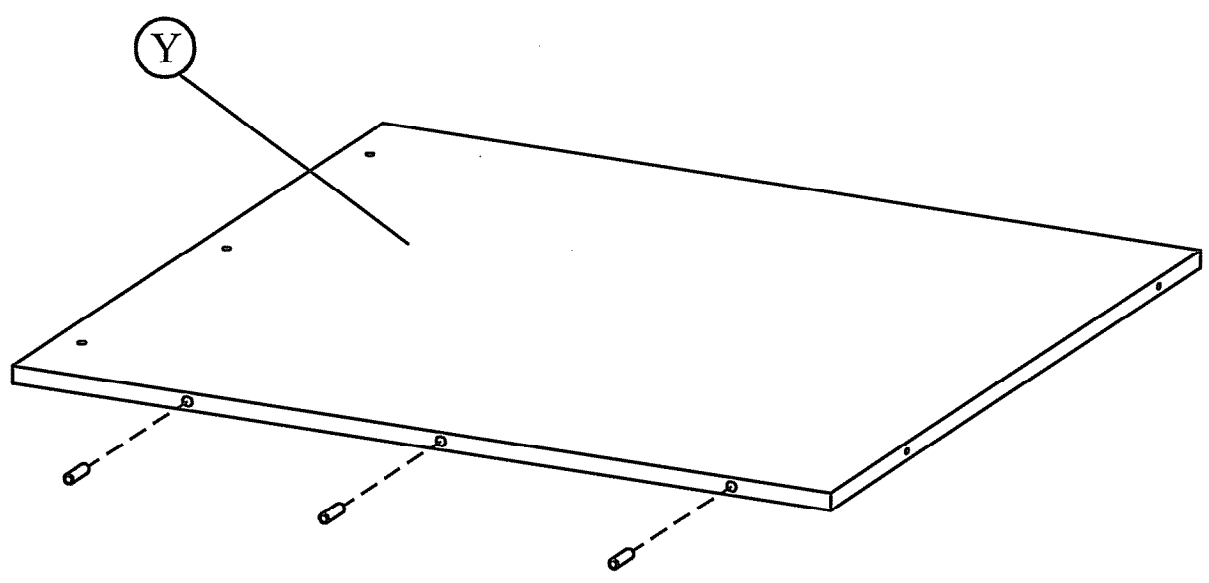

1 - 800 - 950 - 4782

A166351

STEP 50

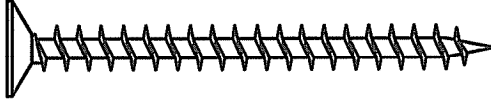
H156849  [2]

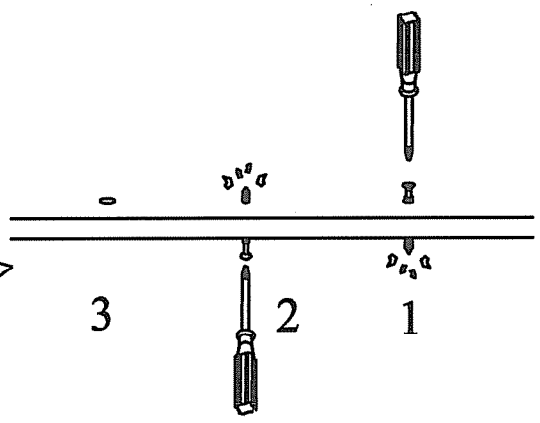
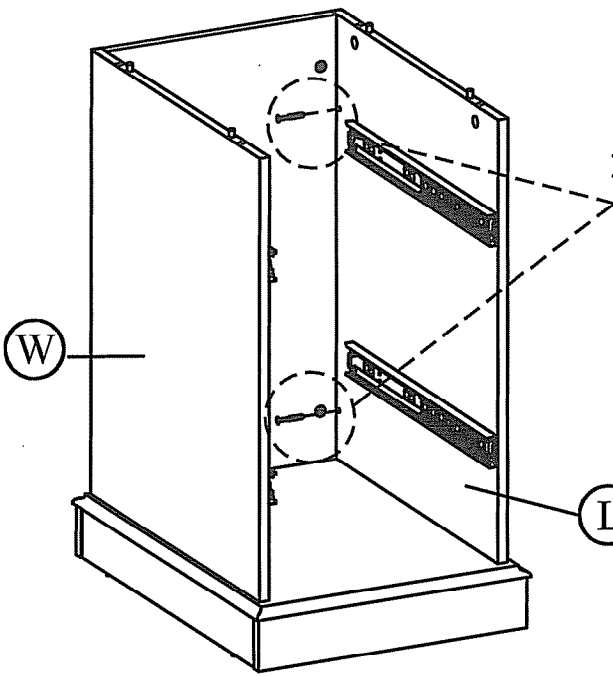

An assistant is required.
 Es necesario un ayudante.
 Un assistant est nécessaire.

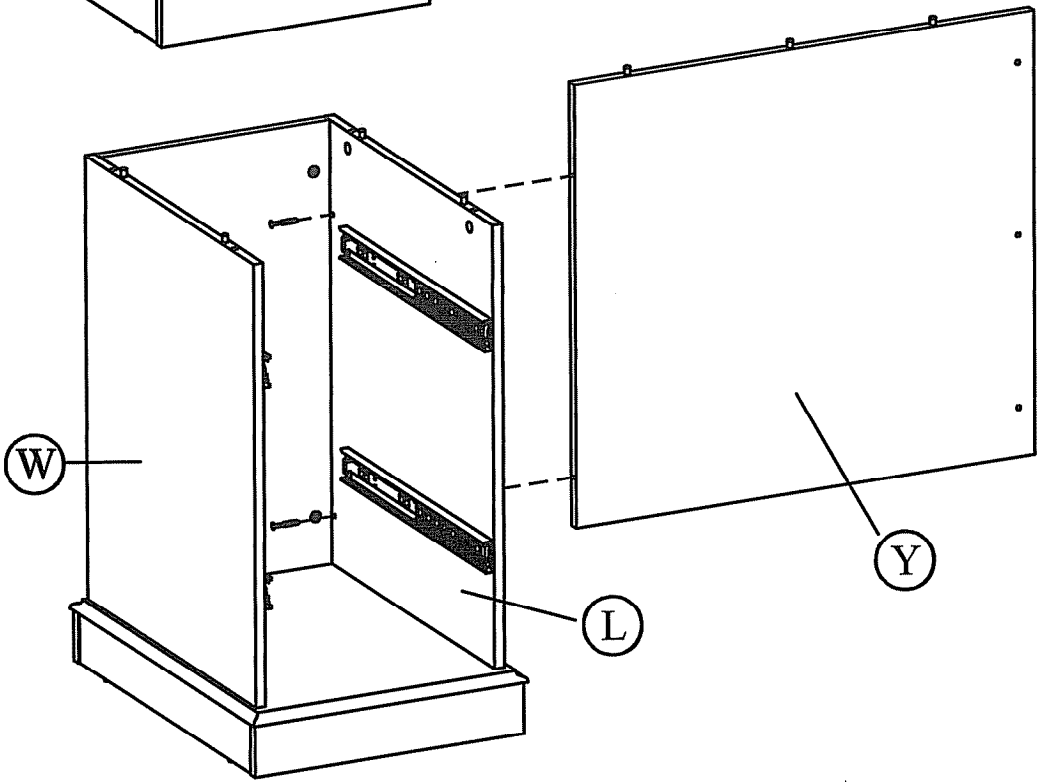

1 - 800 - 950 - 4782

A166351

STEP 51

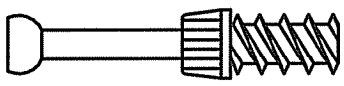
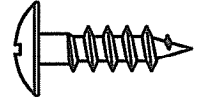
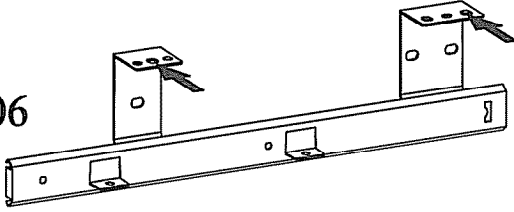
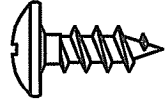
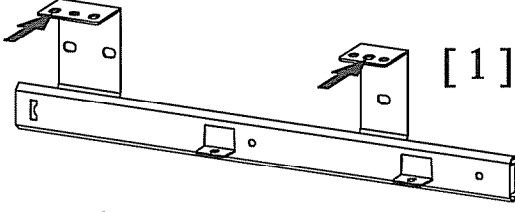
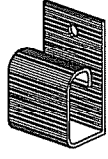
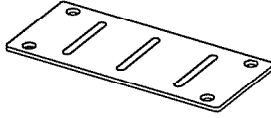
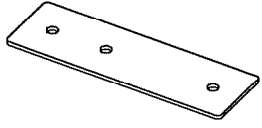
- H159917  [4] H157985  [7]
- Z92806  [1] H157125  [1]
- Z92807  [1] H158031  [1]
- H39922  [1] H158981  [1]

Keyboard option
 Opcion del teclado
 Clavier optionnel

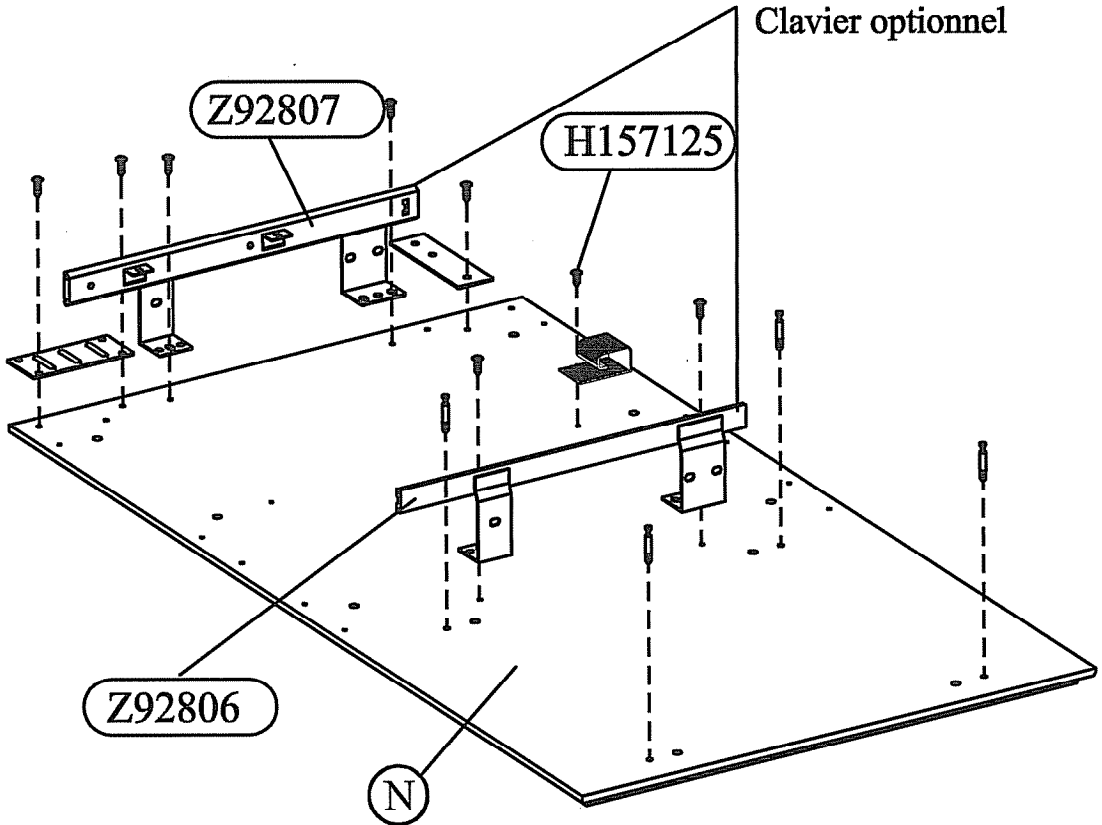

1 - 800 - 950 - 4782

A166351

STEP 52

H159916

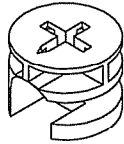

[4]

An assistant is required.
Es necesario un ayudante.
Un assistant est nécessaire.

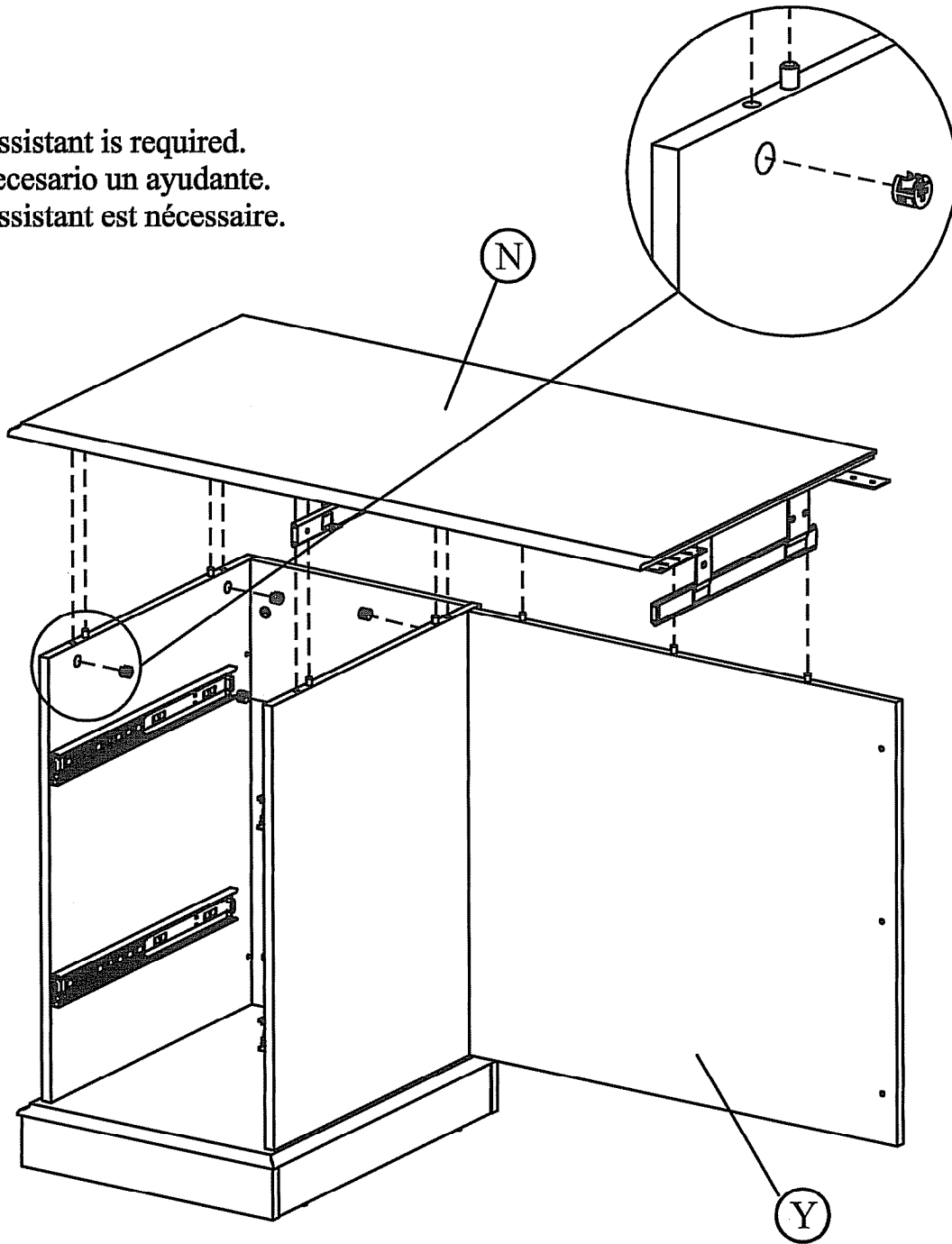

1 - 800 - 950 - 4782

A166351

STEP 53

H157985

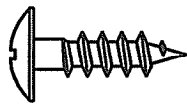

[4]

H158560

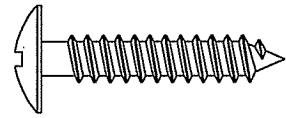

[3]

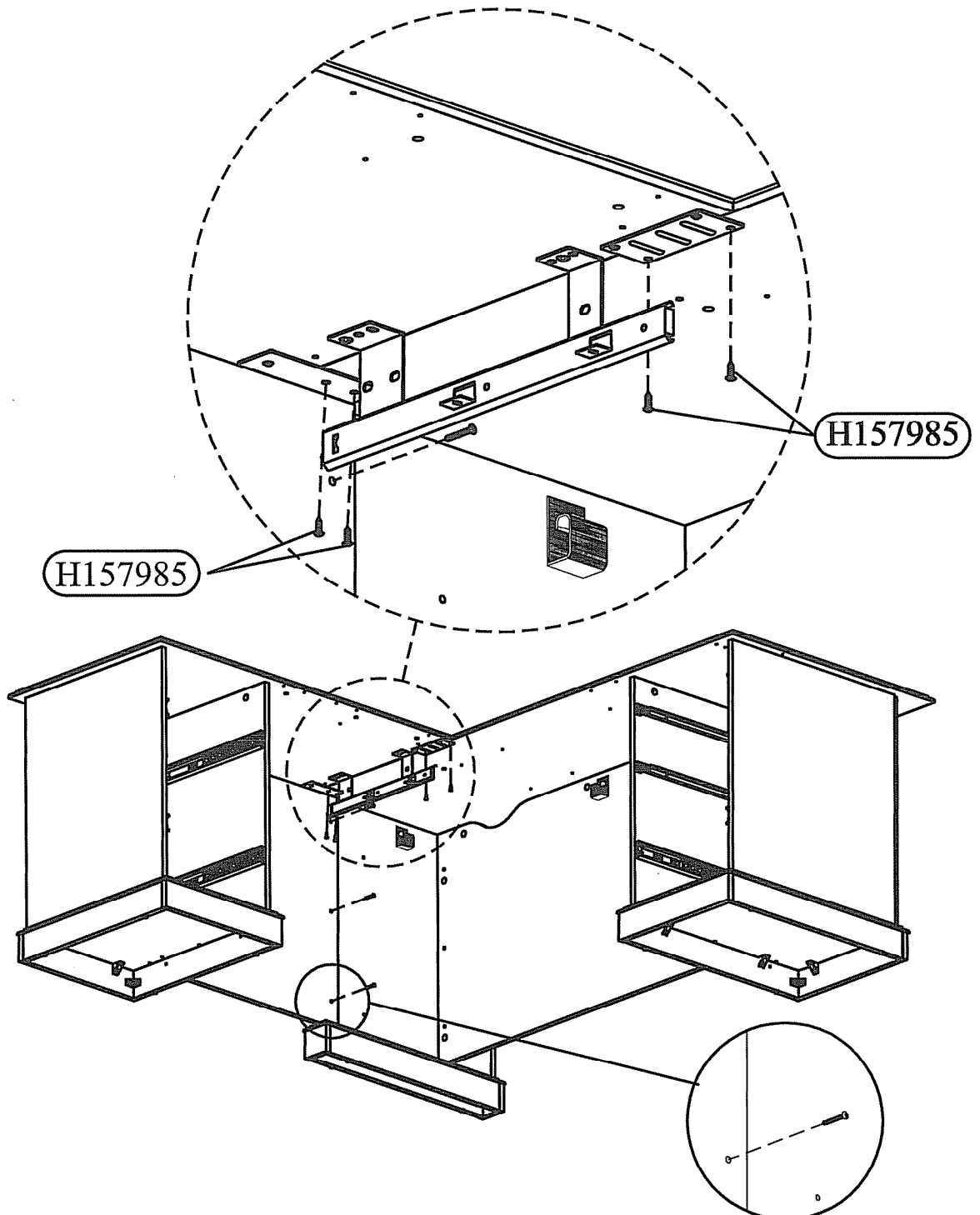

1 - 800 - 950 - 4782

A166351

STEP 54

H156824

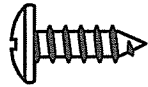

[4]

Finished edge
Borde terminado
Cote fini

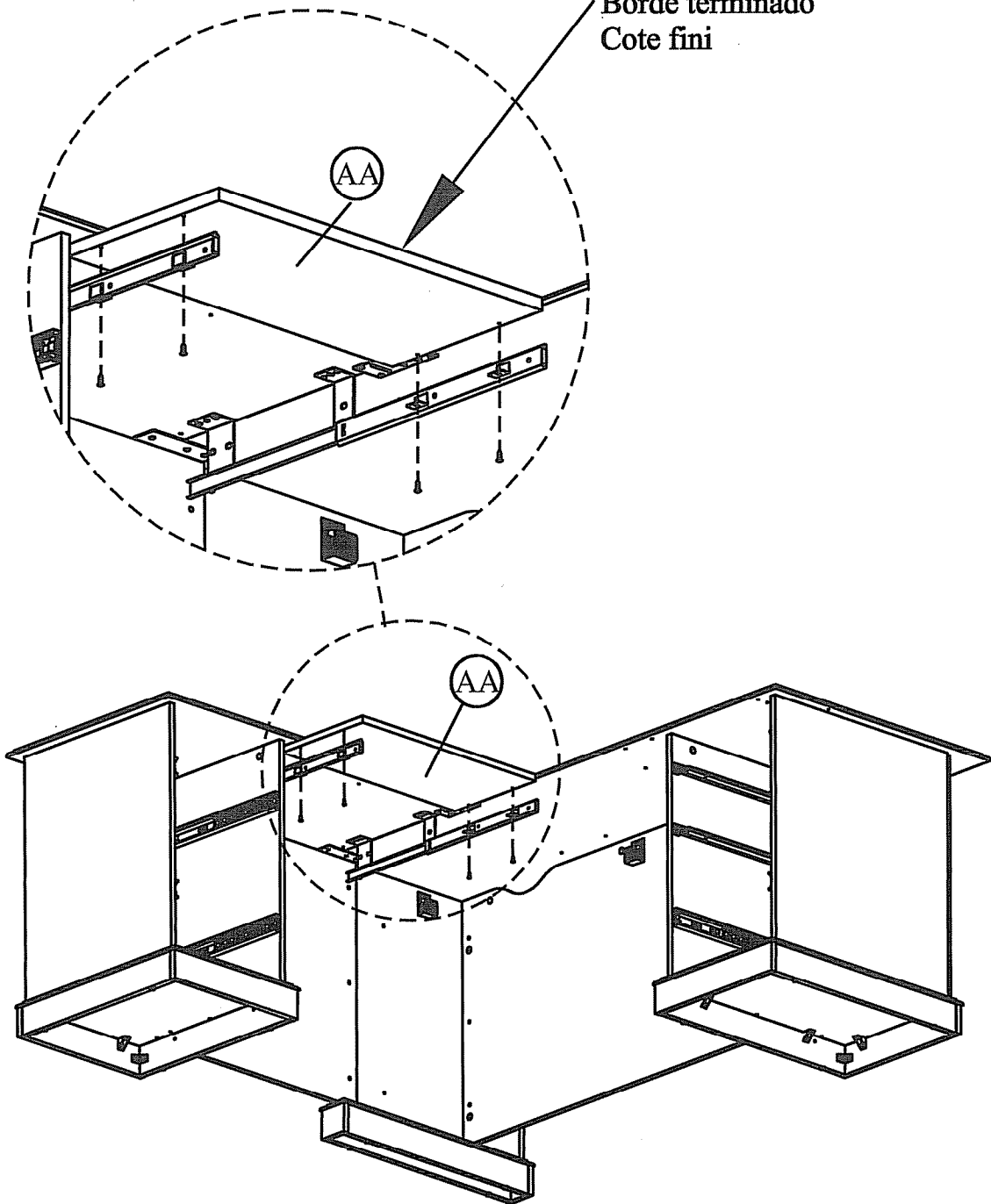

1 - 800 - 950 - 4782

A166351

STEP 55

Keyboard option
Opcion del teclado
Clavier optionnel

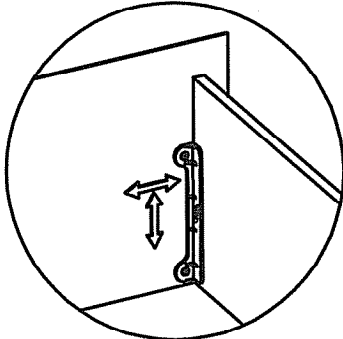
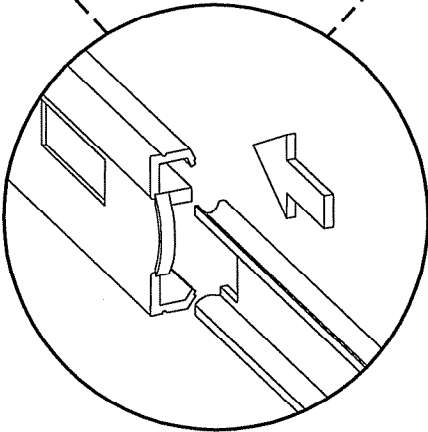
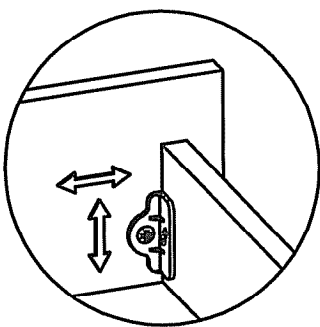
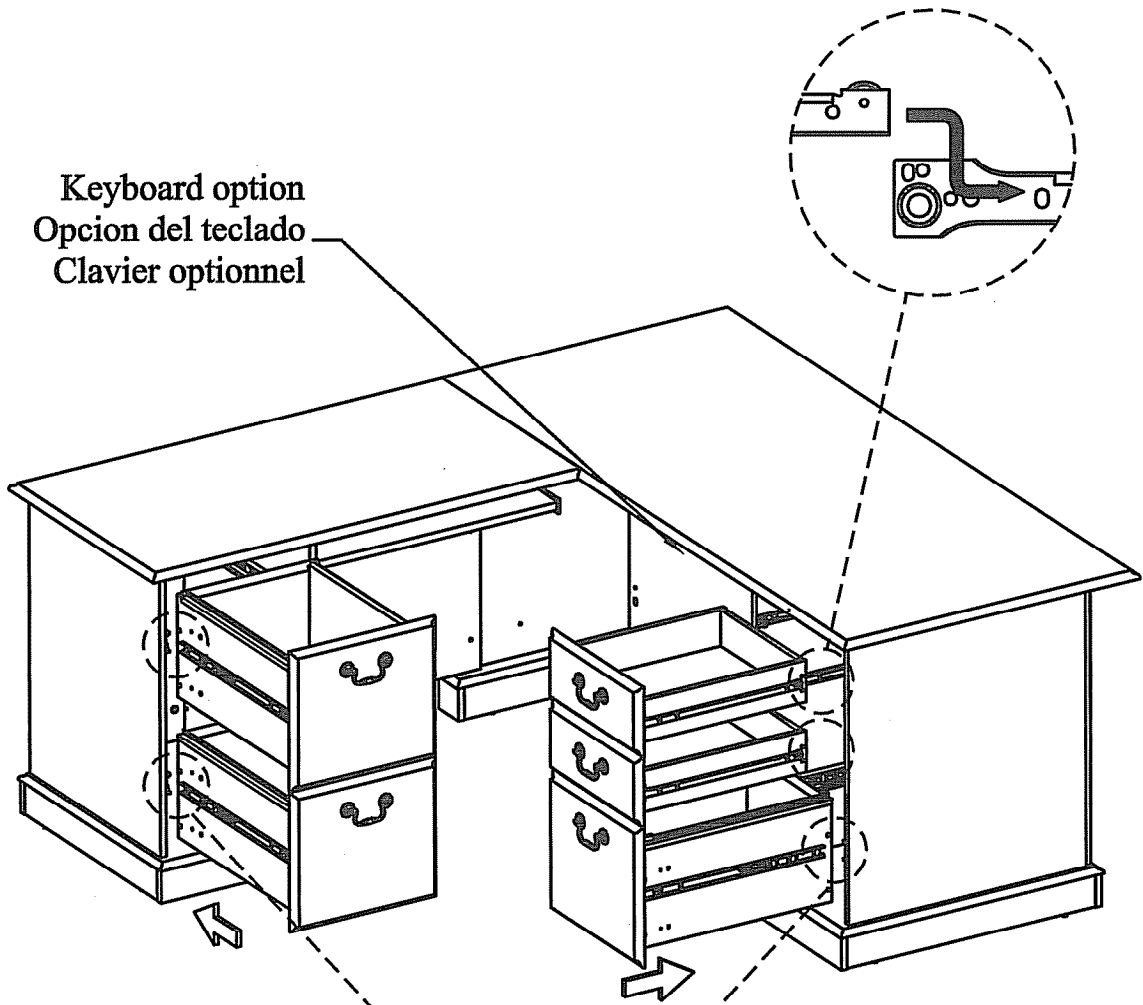

1 - 800 - 950 - 4782

A166351

STEP 56

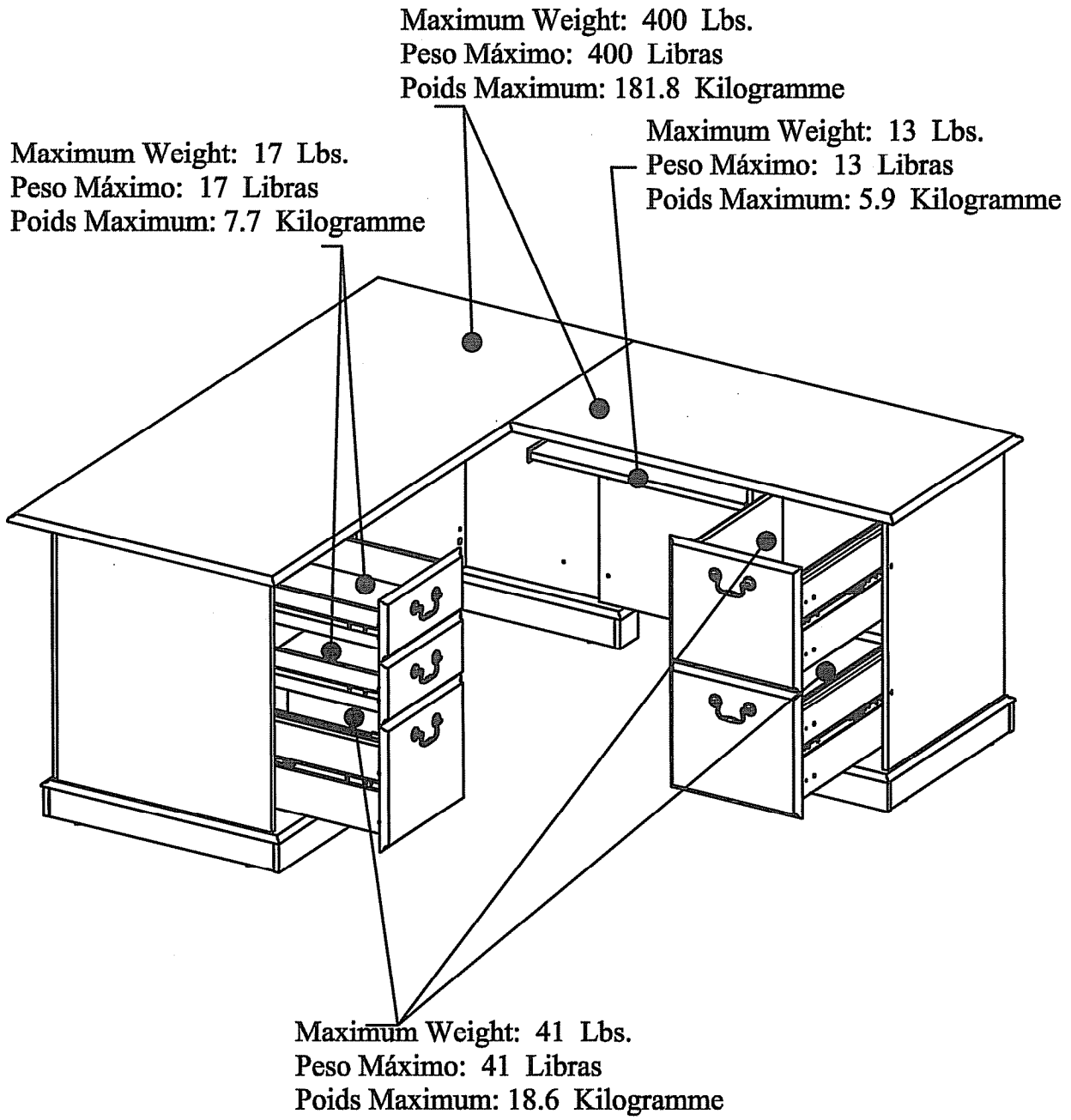

STEP 57

- Move unit to final location.
- Coloque esta unidad en su posición permanente.
- Déplacez l'unité dans l'endroit final.

- Adjust drawer fronts as shown below.
- Ajuste la parte delantera de las gavetas según es indicado.
- Ajustez les façades de tiroir comme montré ci-dessous.

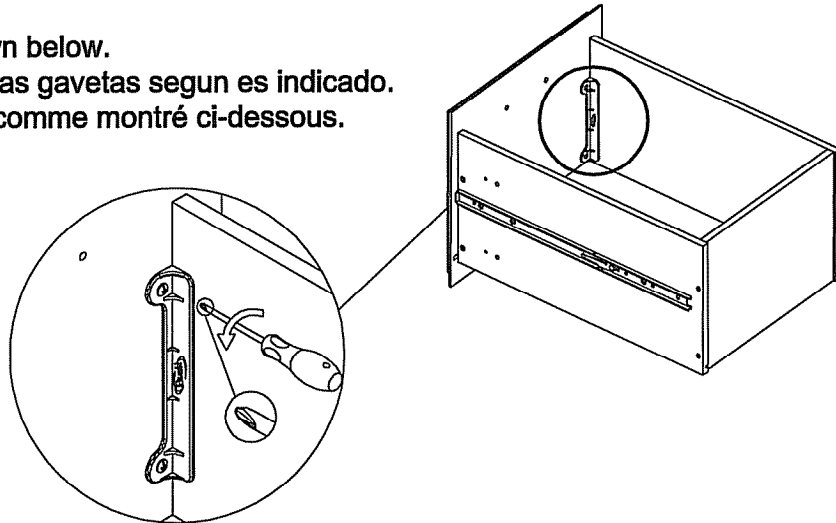

STEP 1.

- Loosen screws on back of drawer front brackets as shown.
- Afloje los tornillos en la parte trasera de la gaveta según es indicado.
- Desserrez les vis dans les appuis en plastique sur le dos de l'avant de tiroir comme montré.

STEP 2.

- Position drawer front as required.
- Ajuste la parte delantera de la gaveta según sea necesario.
- Placez l'avant de tiroir comme nécessaire.

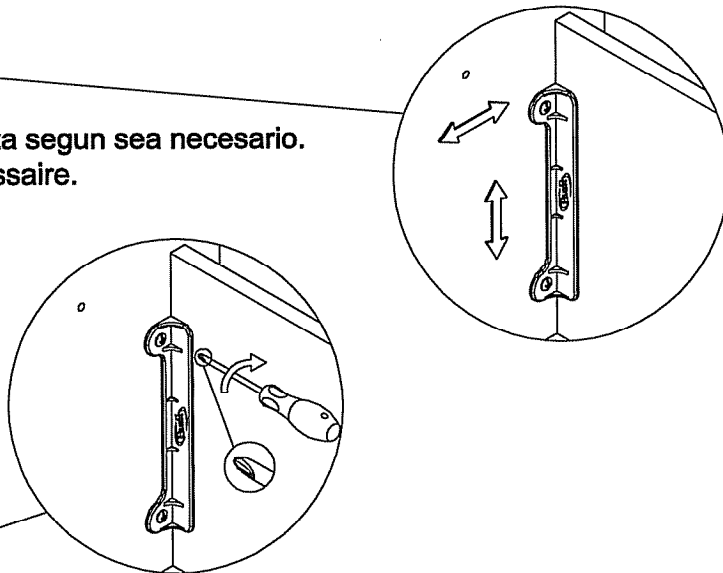

STEP 3.

- Tighten screws while holding drawer front in position.
- Apriete los tornillos mientras sujeta la parte delantera de la gaveta en su posición permanente.
- Serrez les vis tout en tenant l'avant de tiroir en position.