

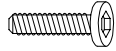







Components and Hardware List

<p>M5/16" x 1-1/2" Allen Head Bolt</p>  <p>A 2 pcs.</p>	<p>M1/4" x 1-1/2" Allen Head Bolt</p>  <p>B 2 pcs.</p>	<p>5/16" Spring Washer</p>  <p>C 2 pcs.</p>	<p>5/16" Flat Washer</p>  <p>D 2 pcs.</p>		
<p>1/4" Spring Washer</p>  <p>E 2 pcs.</p>	<p>1/4" Flat Washer</p>  <p>F 2 pcs.</p>	<p>5mm Allen Wrench</p>  <p>G 1 pc.</p>	<p>4mm Allen Wrench</p>  <p>H 1 pc.</p>		
<p>Lift Cylinder</p>  <p>I 1 pc.</p>	<p>Five Claw Base</p>  <p>J 1 pc.</p>	<p>Feet block</p>  <p>K 5 pcs.</p>	<p>Chair Arm (Left and Right)</p>  <p>L 1 Pair.</p>	<p>Seat and Back Frame</p>  <p>M 1 pc.</p>	<p>Seat Cushion</p>  <p>N 1 pc.</p>
<p>Wood Plug</p>  <p>O 2 pcs.</p>	<p>#8 x 1-1/4" Wood Screw</p>  <p>P 4 pcs.</p>	<p>Be sure to check all packing material carefully for small parts, which may have come loose inside the carton during shipment. Separate and check all parts against the Components and Hardware List above.</p>			

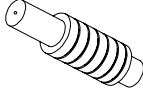
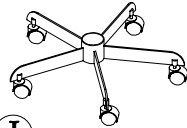
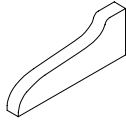
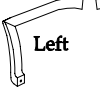
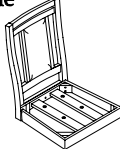
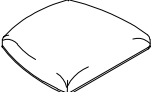

84538 Desk Chair

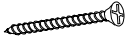
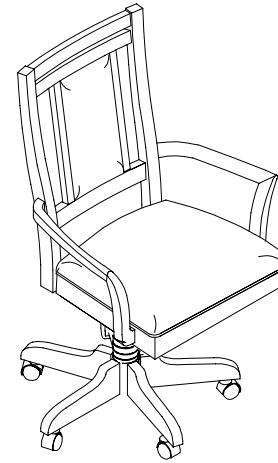
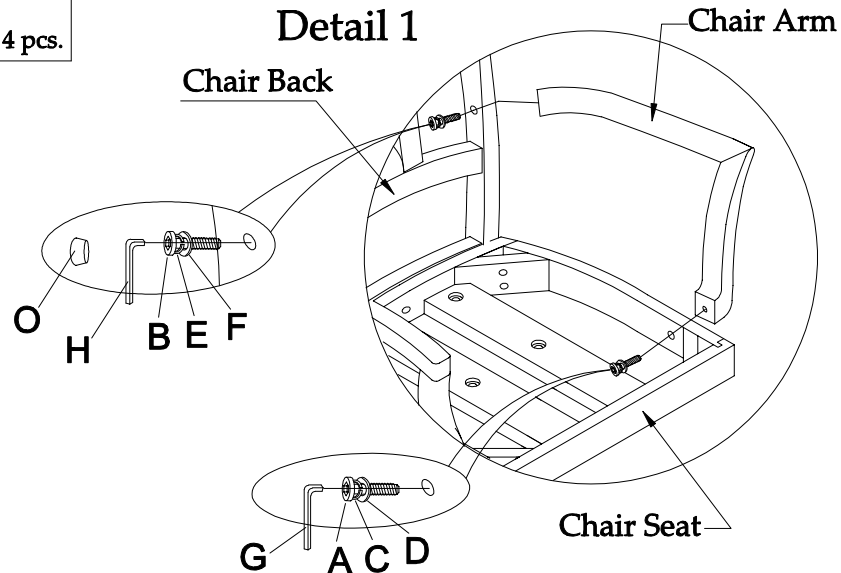

Step 1: Place the Chair Seat and Back Frame on a padded surface, and assemble the Left and Right Arm to the Seat & Back Frame using a M5/16" x 1-1/2" long Allen Head Bolt (A), Spring Washer (C), and Flat Washer (D), at the front of the Arm. Do not fully tighten bolt until after fully attaching back end of arm. Attach the back end of the Arm to the Chair Back using a M1/4" x 1-1/2" long Allen Head Bolt (B), Spring Washer (E), and Flat Washer (F). Tighten the Bolt at the back end using the 4mm Allen Wrench (H) and then tighten the Bolt at the front using the 5mm Allen Wrench (G). Press the Wood Plugs(O) into the holes on the Chair Back at the Chair Arms. Repeat for other Arm.

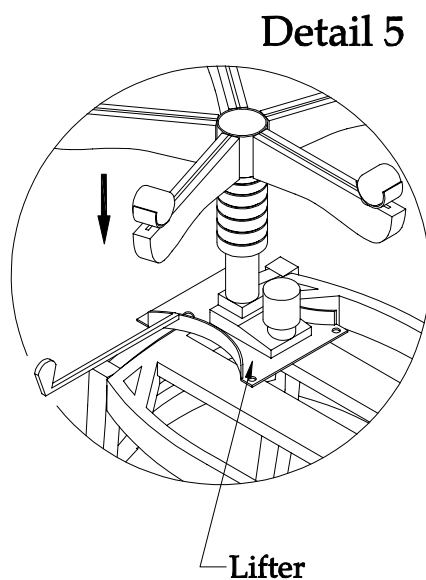
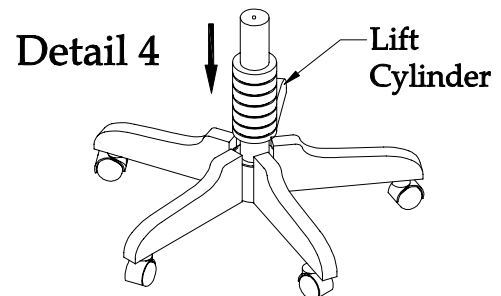
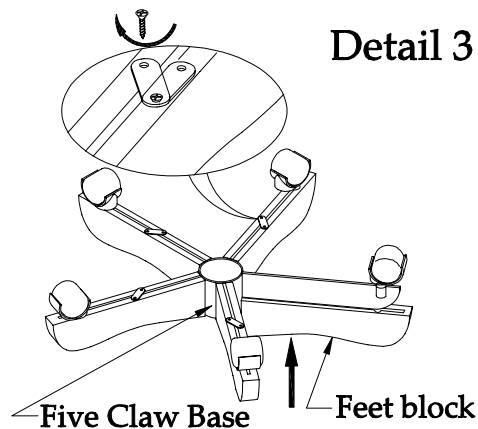
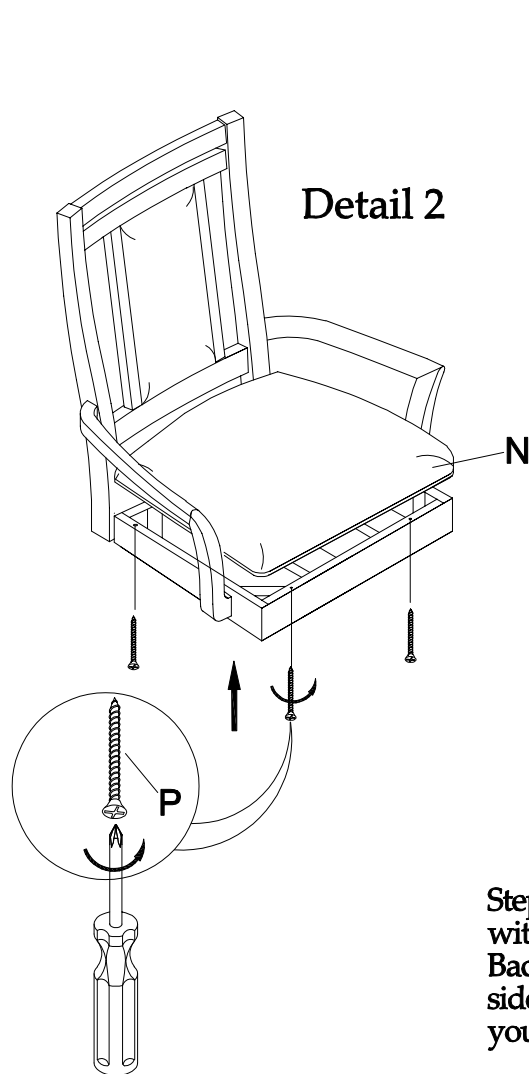

Step 2: Place the Chair Seat Cushion on the corner of a table, with the front edge pointing inward. Position the Seat and Back Frame on the Cushion with the same overhang on the sides. Attach using the 1-1/4" long Wood Screws (P) and your Phillips Screwdriver, as shown.

Step 3: Assemble the Feet Blocks to the top of the Five Claw Base (as shown in detail 3) and secure using the wood screws and your Phillips screwdriver. Place the chair base upright on the floor and assemble the Lift Cylinder onto the Five Claw Base (as shown in detail 4).

Step 4: Position the hole of the lift mechanism on top of the Lift Cylinder and press down on the seat to secure (as shown in detail 5).

Note: To prevent possible damage to some types of flooring, never roll casters on unprotected hardwood or vinyl flooring.

The lift mechanism is in a locked position for shipping. To unlock, pull straight out on the handle, and then the lift cylinder can be activated by lifting the handle.